



HOSHIZAKI

Service Manual

Modular Crescent Cuber with

Models

KML-325MAJ, MWJ

KML-500MAJ, MWJ

KML-700MAJ, MWJ, MRJ



hoshizakiamerica.com

Number: 73215
Issued: 6-16-2017
Revised: 9-11-2020

⚠ WARNING

Only qualified service technicians should install and service the appliance. To obtain the name and phone number of your local Hoshizaki Certified Service Representative, visit www.hoshizaki.com. No service should be undertaken until the technician has thoroughly read this Service Manual. Failure to service and maintain the appliance in accordance with this manual will adversely affect safety, performance, component life, and warranty coverage and may result in costly water damage. Proper installation is the responsibility of the installer. Product failure or property damage due to improper installation is not covered under warranty.

Should the reader have any questions or concerns which have not been satisfactorily addressed, please call, send an e-mail message, or write to the Hoshizaki Technical Support Department for assistance.

Phone: 1-800-233-1940; (770) 487-2331

Fax: 1-800-843-1056; (770) 487-3360

E-mail: techsupport@hoshizaki.com

HOSHIZAKI AMERICA, INC.

618 Highway 74 South

Peachtree City, GA 30269

Attn: Hoshizaki Technical Support Department

Web Site: www.hoshizaki.com

NOTE: To expedite assistance, all correspondence/communication **MUST** include the following information:

- Model Number _____
- Serial Number _____
- Complete and detailed explanation of the problem.

IMPORTANT

This manual should be read carefully before the appliance is serviced. Read the warnings and guidelines contained in this manual carefully as they provide essential information for the continued safe use, service, and maintenance of the appliance. Retain this manual for any further reference that may be necessary.

CONTENTS

Important Safety Information	5
I. Construction and Water/Refrigeration Circuit Diagram	7
A. Construction	7
1. Air-Cooled (MAJ)	7
2. Water-Cooled (MWJ)	8
3. Remote Air-Cooled (MRJ).....	9
B. Water/Refrigeration Circuit Diagram.....	10
1. Air-Cooled Models (MAJ)	10
2. Water-Cooled Models (MWJ).....	11
3. Remote Models (MRJ).....	12
II. Sequence of Operation and Service Diagnosis	13
A. Sequence of Operation Flow Chart.....	13
1. Operation Flow Chart.....	13
2. Shutdown Flow Chart	14
3. Freeze-Time Correction Chart (CB:2A7664-02)	15
B. Service Diagnosis	16
C. Freeze-Time Correction Cycle (90 min.) (CB:2A7664-02).....	24
D. Control Board Check	26
E. Bin Control Check	27
F. Float Switch Check and Cleaning	28
G. Thermistor Check.....	30
H. Switches.....	31
I. Diagnostic Tables.....	32
J. Freeze-Up Check List	36
III. Controls and Adjustments	37
A. Control Board Layout	38
B. LED Lights and Audible Alarm Safeties	39
C. Settings and Adjustments.....	40
1. Default Dip Switch Settings	40
2. Harvest Time (S4 dip switch 1 & 2).....	41
3. Pump-Out Time/Harvest Time During Pump-Out (S4 dip switch 3 & 4).....	41
4. Pump-Out Frequency Control (S4 dip switch 5).....	42
5. Harvest Pump Time (Harvest Assist Duration) (S4 dip switch 6)	42
6. Harvest Pump Time (Harvest Assist) (S4 dip switch 7)	43
7. Factory Use (S4 dip switch 8).....	43
8. Freeze Timer (S4 dip switch 9 & 10)	44
9. Float Switch Selector (S5 dip switch 1)	44
10. Refill Counter (S5 dip switch 2 and 3)	44
11. Minimum Harvest Time (S5 dip switch 4)	45
12. Slush Control (S5 dip switch 5)	45

IV. Refrigeration Circuit and Component Service Information.....	46
A. Refrigeration Circuit Service Information	46
B. Component Service Information.....	49
C. Water Regulating Valve Adjustment (water-cooled model)	49
V. Maintenance	50
VI. Preparing the Appliance for Periods of Non-Use	51
VII. Disposal.....	53
VIII. Technical Information.....	54
A. Specification and Performance Data Sheets.....	54
1. KML-325MAJ.....	54
2. KML-325MWJ	55
3. KML-500MAJ	56
4. KML-500MWJ	57
5. KML-700MAJ	58
6. KML-700MWJ	59
7. KML-700MRJ.....	60
B. Wiring Diagram.....	61

Important Safety Information

Throughout this manual, notices appear to bring your attention to situations which could result in death, serious injury, damage to the appliance, or damage to property.

⚠ WARNING Indicates a hazardous situation which could result in death or serious injury.

NOTICE Indicates a situation which could result in damage to the appliance or property.

IMPORTANT Indicates important information about the use and care of the appliance.

⚠ WARNING

The appliance should be destined only to the use for which it has been expressly conceived. Any other use should be considered improper and therefore dangerous. The manufacturer cannot be held responsible for injury or damage resulting from improper, incorrect, and unreasonable use. Failure to service and maintain the appliance in accordance with this manual will adversely affect safety, performance, component life, and warranty coverage and may result in costly water damage.

To reduce the risk of death, electric shock, serious injury, or fire, follow basic precautions including the following:

- Only qualified service technicians should install and service this appliance.
- The appliance must be installed in accordance with applicable national, state, and local codes and regulations.
- Electrical connection must be hard-wired and must meet national, state, and local electrical code requirements. Failure to meet these code requirements could result in death, electric shock, serious injury, fire, or damage.
- The icemaker requires an independent power supply of proper capacity. See the nameplate for electrical specifications. Failure to use an independent power supply of proper capacity can result in a tripped breaker, blown fuses, damage to existing wiring, or component failure. This could lead to heat generation or fire.
- **THE ICEMAKER MUST BE GROUNDED.** Failure to properly ground the icemaker could result in death or serious injury.
- Move the control switch to the "OFF" position and turn off the power supply before servicing. Lockout/Tagout to prevent the power supply from being turned back on inadvertently.
- To reduce the risk of electric shock, do not touch the control switch or service switch with damp hands.
- Do not make any alterations to the unit. Alterations could result in electric shock, injury, fire, or damage to the unit.
- The appliance is not intended for use by persons (including children) with reduced physical, sensory, or mental capabilities, or lack of experience and knowledge, unless they have been given supervision or instruction concerning use of the appliance by a person responsible for their safety.

⚠ WARNING, continued

- Children should be properly supervised around this appliance.
- Do not climb, stand, or hang on the appliance or allow children or animals to do so. Serious injury could occur or the appliance could be damaged.
- Do not use combustible spray or place volatile or flammable substances near the appliance. They might catch fire.
- Keep the area around the appliance clean. Dirt, dust, or insects in the appliance could cause harm to individuals or damage to the appliance.

Additional Warning for Remote Models

- **THE REMOTE CONDENSER UNIT MUST BE GROUNDED.** The power supply and ground connection to the remote condenser unit are supplied from the icemaker. Failure to properly ground the remote condenser unit could result in death or serious injury.
- Move the icemaker control switch to the "OFF" position and turn off the power supply to the icemaker before servicing the remote condenser unit. Lockout/Tagout to prevent the power supply from being turned back on inadvertently.

NOTICE

- Follow the instructions in this manual carefully to reduce the risk of costly water damage.
- In areas where water damage is a concern, install in a contained area with a floor drain.
- Install the appliance in a location that stays above freezing. Normal operating ambient temperature must be within 45°F to 100°F (7°C to 38°C).
- Do not leave the icemaker on during extended periods of non-use, extended absences, or in sub-freezing temperatures. To properly prepare the icemaker for these occasions, follow the instructions in "VI. Preparing the Appliance for Periods of Non-Use."
- Do not place objects on top of the appliance.
- The dispenser unit/ice storage bin is for ice use only. Do not store anything else in the dispenser unit/ice storage bin.

I. Construction and Water/Refrigeration Circuit Diagram

A. Construction

1. Air-Cooled (MAJ)

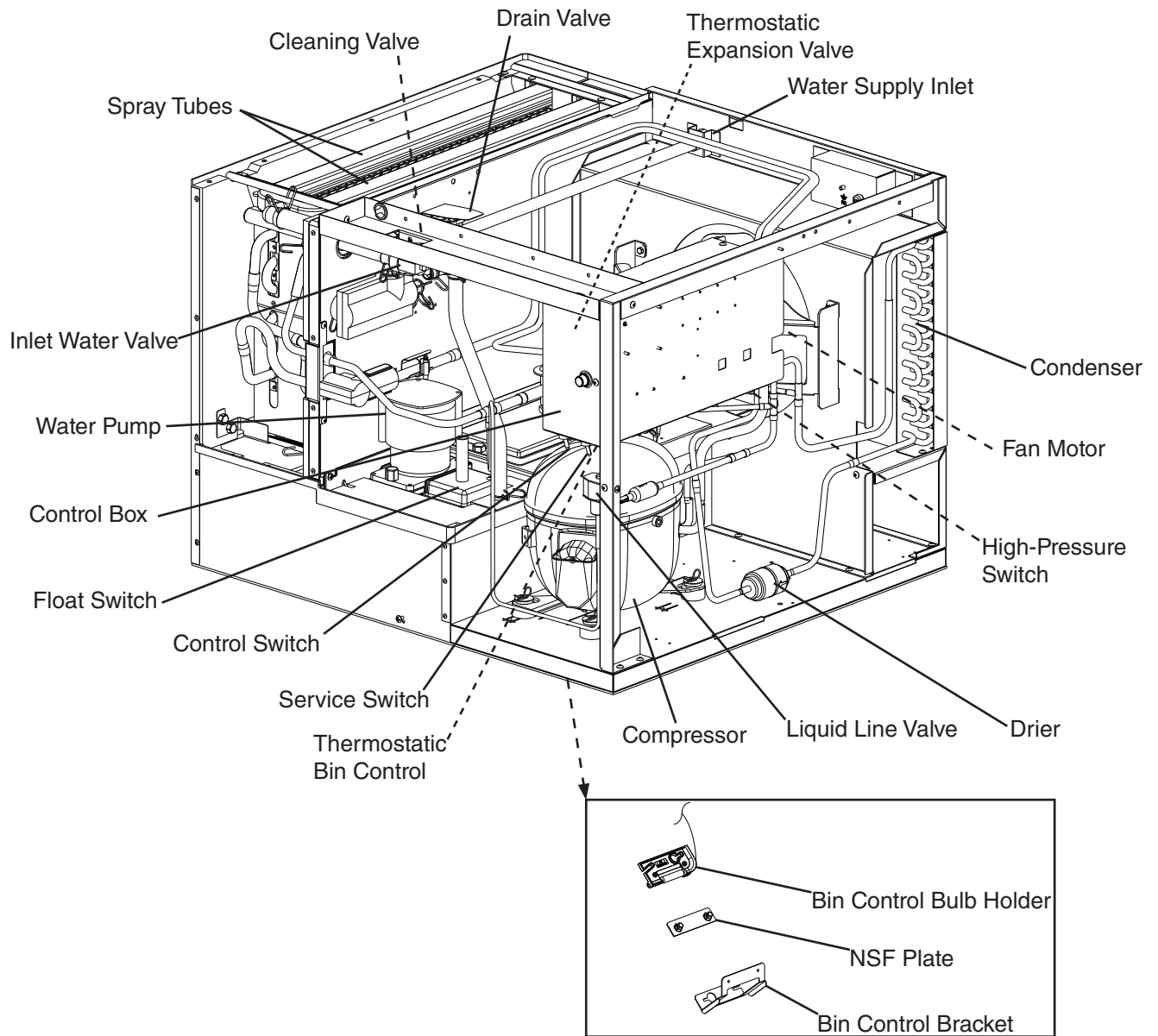

Model Shown: KML-500MAJ

2. Water-Cooled (MWJ)

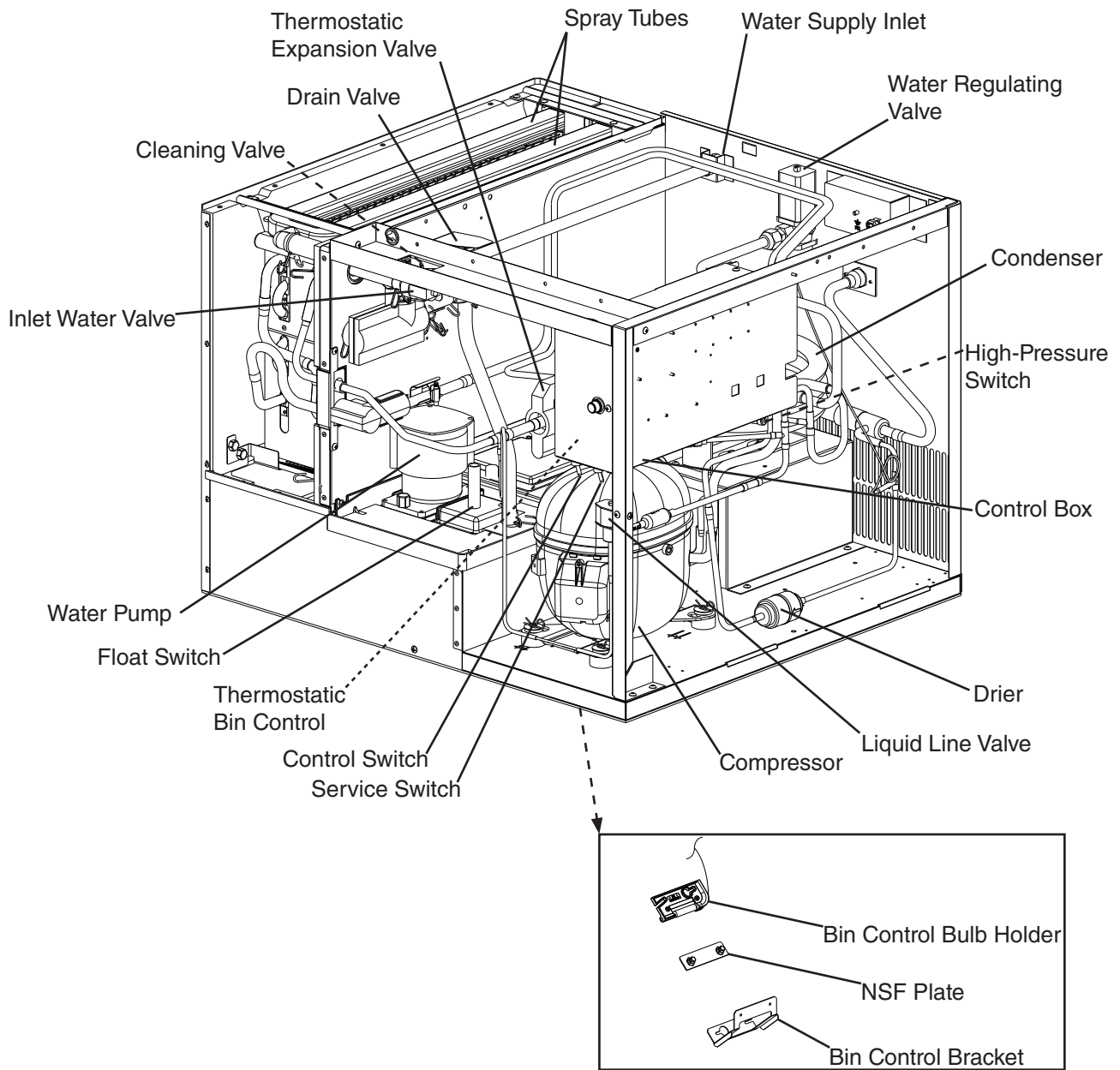

Model Shown: KML-325MWJ

3. Remote Air-Cooled (MRJ)

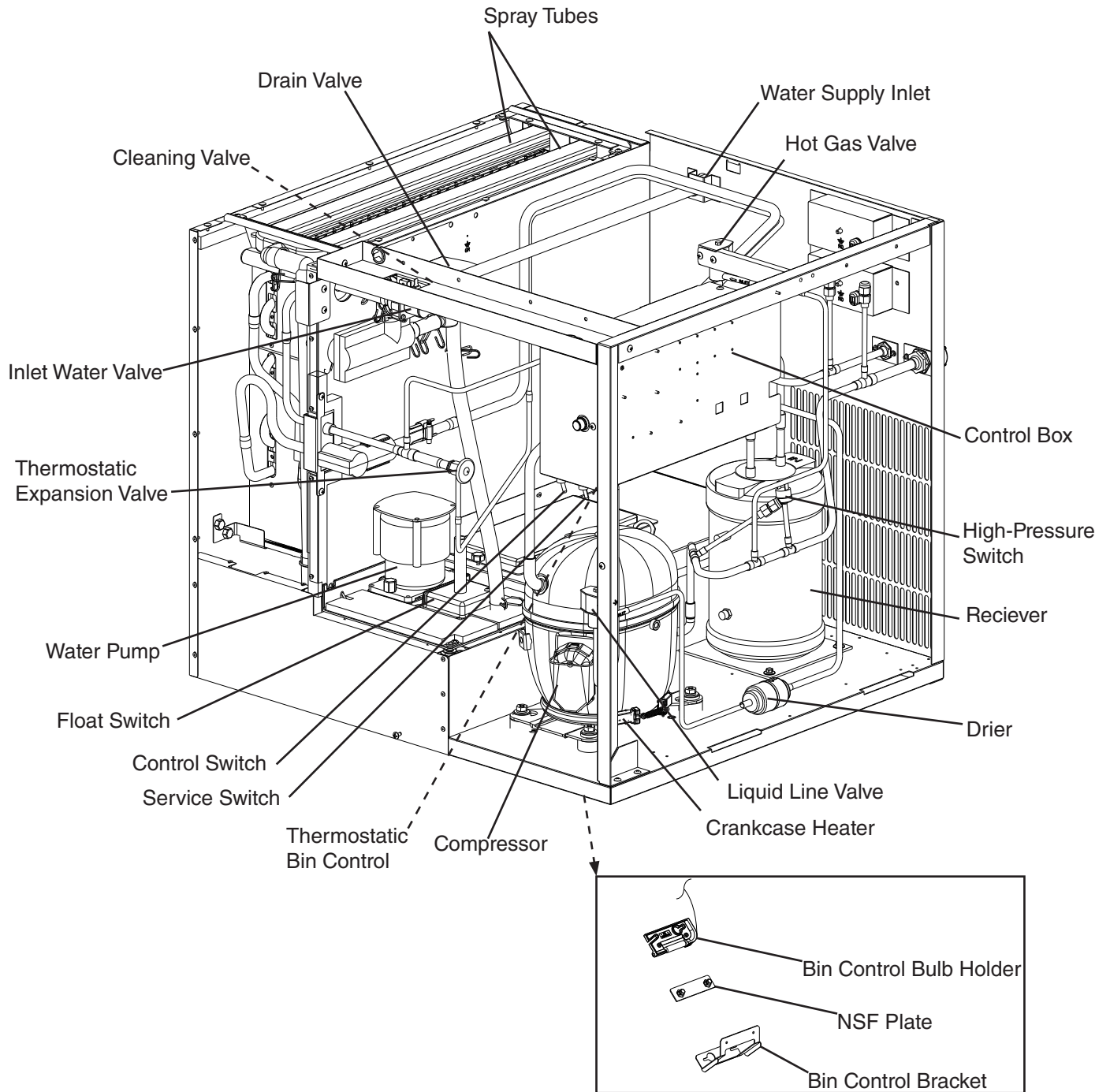

Model Shown: KML-700MRJ

B. Water/Refrigeration Circuit Diagram

1. Air-Cooled Models (MAJ)

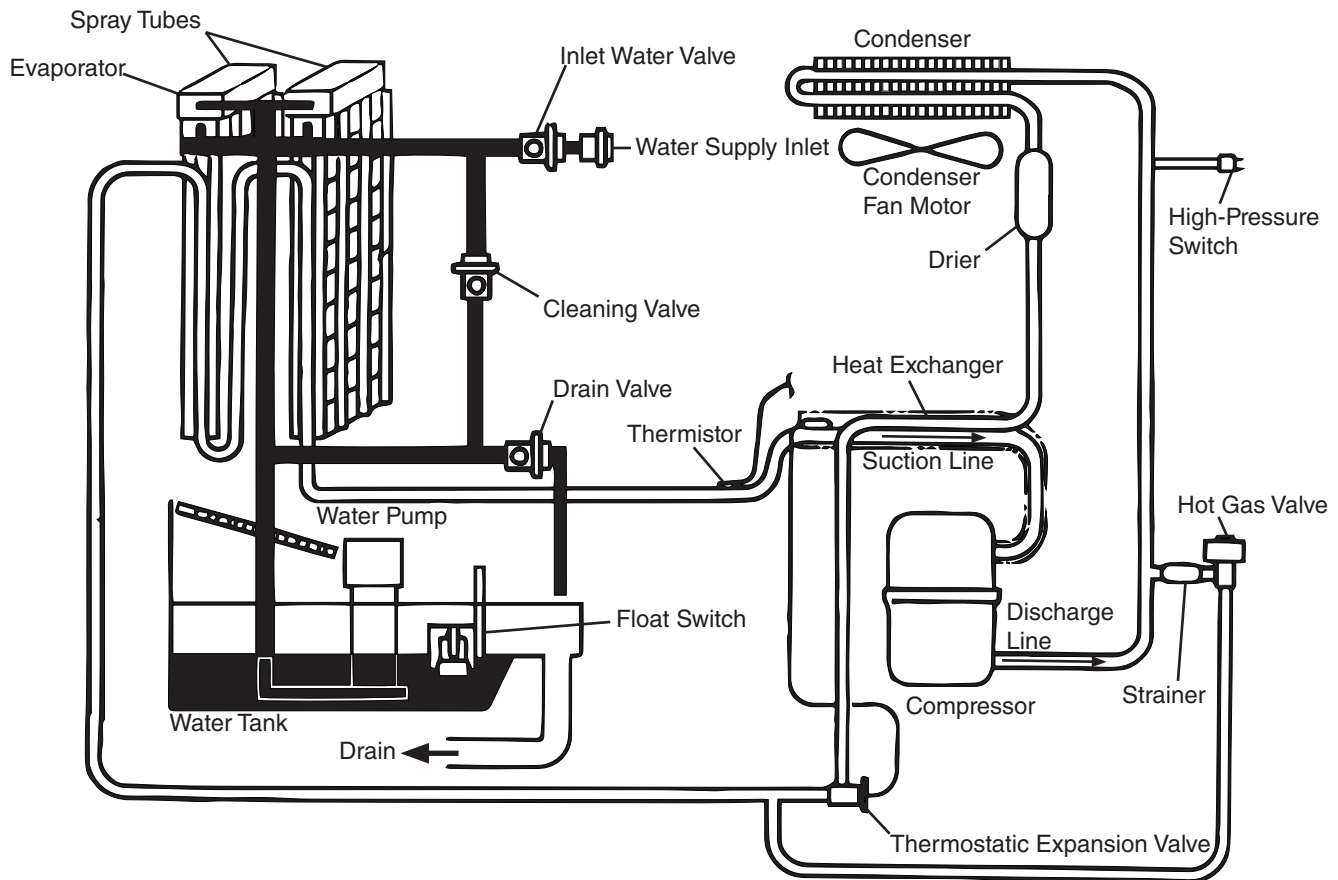

— Refrigeration Circuit
— Water Circuit

2. Water-Cooled Models (MWJ)

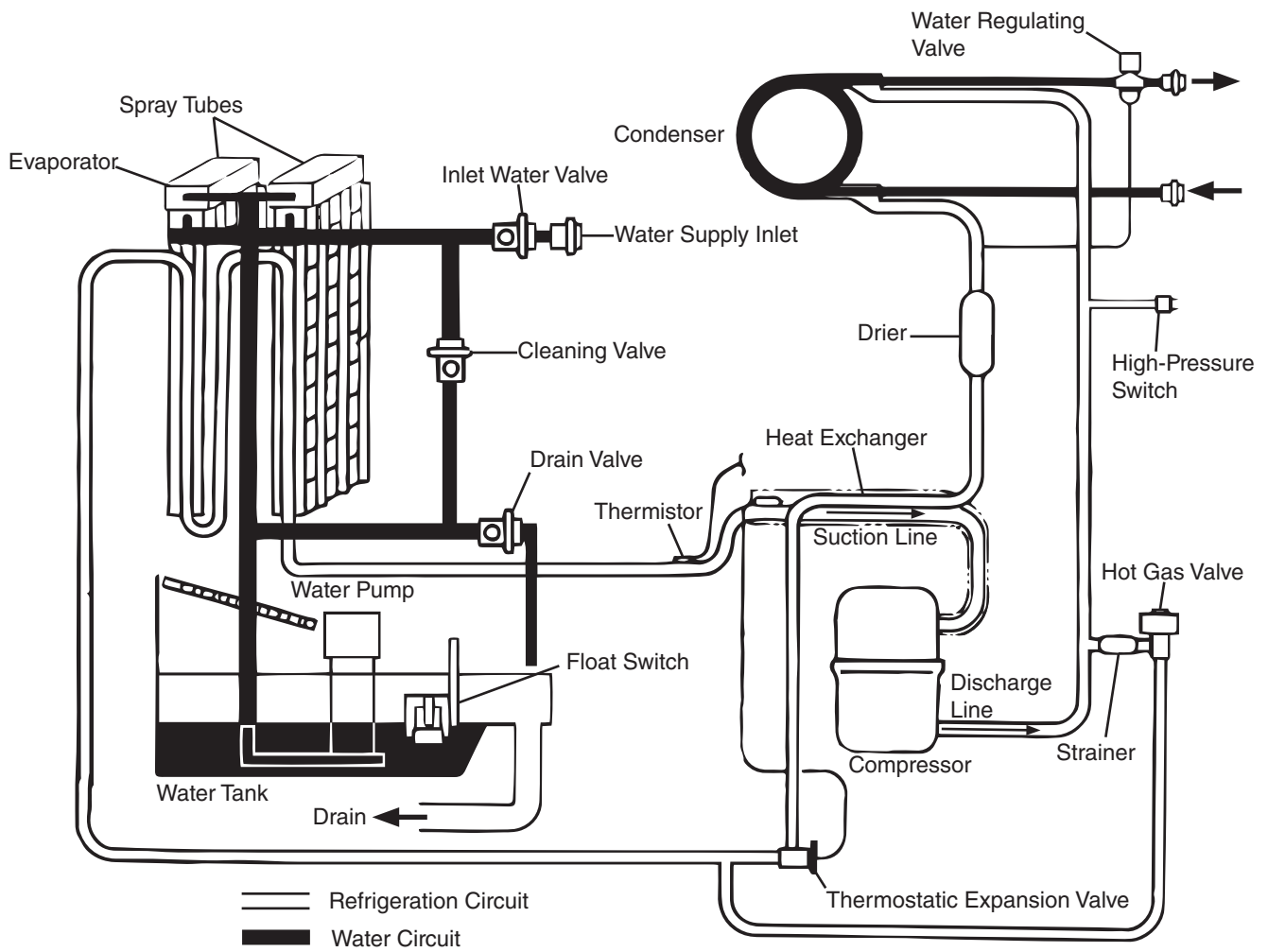

3. Remote Models (MRJ)

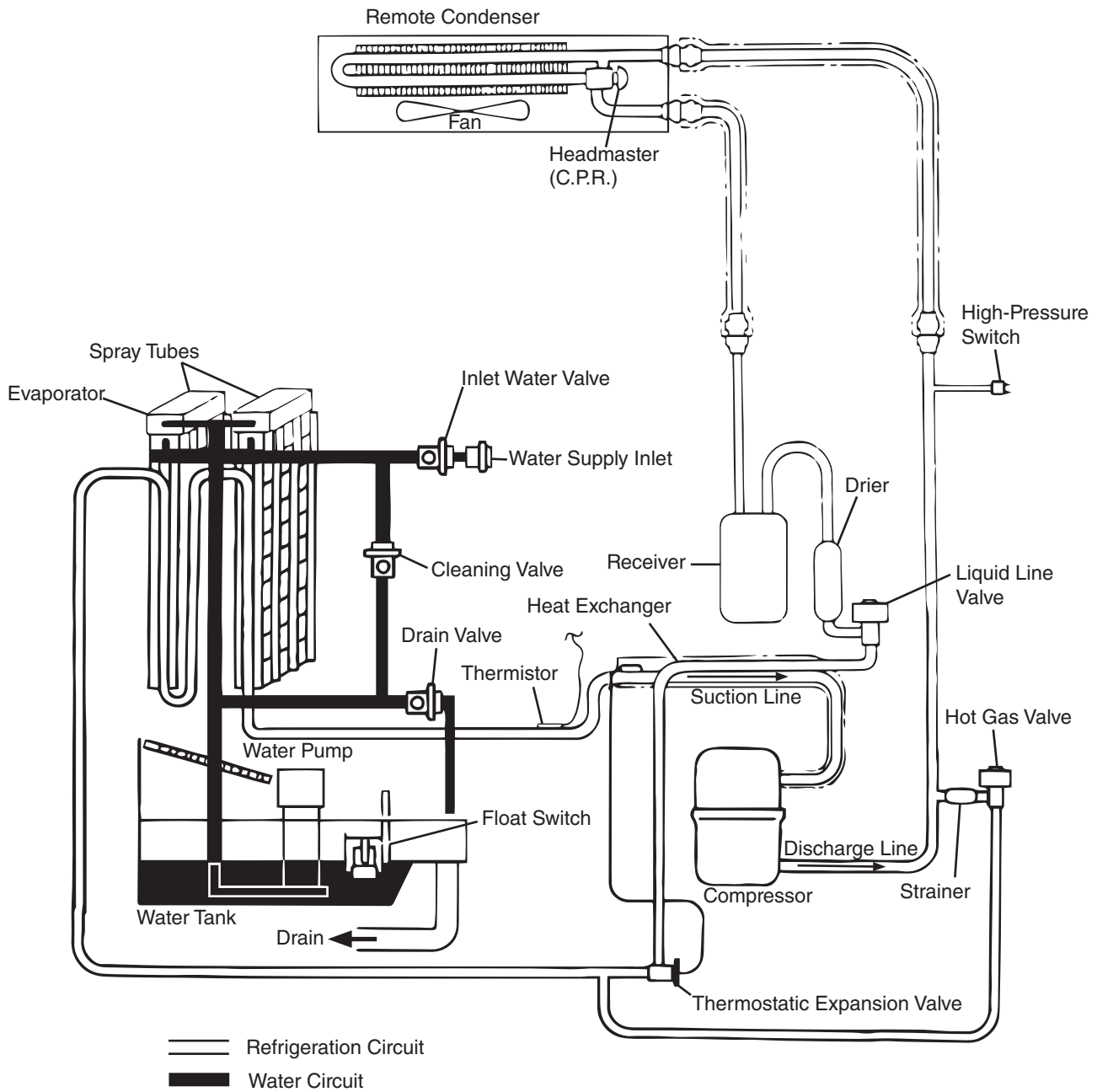

II. Sequence of Operation and Service Diagnosis

A. Sequence of Operation Flow Chart

1. Operation Flow Chart

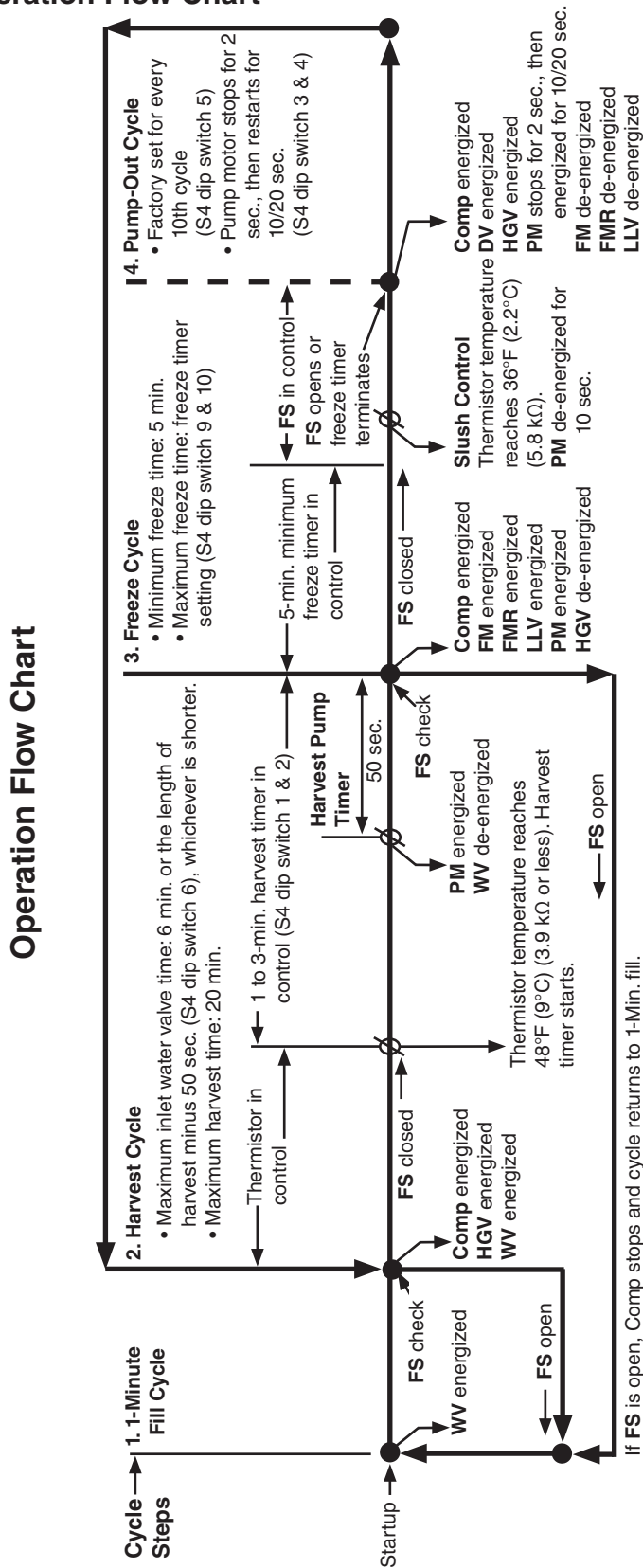

Components Energized when the Control Switch is in the "SERVICE" Position

When in the "SERVICE" position, the control switch supplies power to the service switch and the icemaker is in service mode. The service switch has three positions: "DRAIN," "CIRC," and "WASH." See the information below for details of each function.

DRAIN	Power is supplied to the pump motor and drain valve. This drains the water tank.
CIRCULATE	Power is supplied to the pump motor only. This can be used to circulate cleaner and sanitizer over the outside surface of the evaporator for extended periods of time.
WASH	Power is supplied to the pump and wash valve. This operation is used to circulate cleaner and sanitizer over both the inside and outside surfaces of the evaporator.

Legend:

Comp	compressor
DV	drain valve
FM	fan motor
FMR	fan motor-remote
FS	float switch
HGV	hot gas valve
LLV	liquid line valve
PM	pump motor
WV	inlet water valve

2. Shutdown Flow Chart

Shutdown Flow Chart

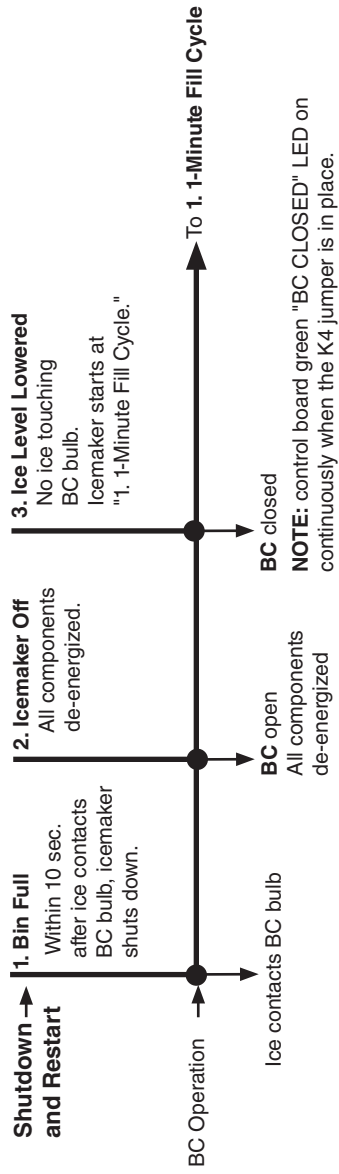

Control board 2A7664-02 retains freeze-time correction
count data between bin control restarts.

Freeze Time Differential Exceeded. Minimum and Maximum Freeze times have exceeded differential parameters.

Freeze-Time Correction function is enabled when S4 Dip Switch 7 is in the "ON" position. CB monitors freeze time. After 3 freeze cycles, CB compares the minimum and maximum differential of the 3 freeze cycle times. Every freeze cycle time after the third freeze cycle time is added to the minimum/maximum calculation.

Example: After 8 cycles, if the differential between the shortest cycle (minimum) and the longest cycle (maximum) is equal to or greater than 427 sec. a freeze-time correction cycle is initiated:

Number of Freeze Cycles	Differential Value in Sec.
3	254
4	309
5	349
6	380
7	406
8	427
9	446
10	462

Note: When 1st freeze-time correction cycle is initiated, CB "POWER OK" LED starts blinking. On 2nd freeze-time correction cycle, if CB "POWER OK" LED has been reset, CB "POWER OK" LED starts blinking. If CB "POWER OK" had not been reset after 1st freeze-time correction cycle CB "POWER OK" LED continues to blink. After 3rd freeze-time correction cycle in 36 hours, CB yellow "EXT HARVEST" LED starts blinking. Appliance continues to operate and LEDs continue to blink until ALARM RESET button is pressed with power on.

Control Board 2A7664-02 Freeze-Time Correction Flow Chart

3. Freeze-Time Correction Chart (CB:2A7664-02)

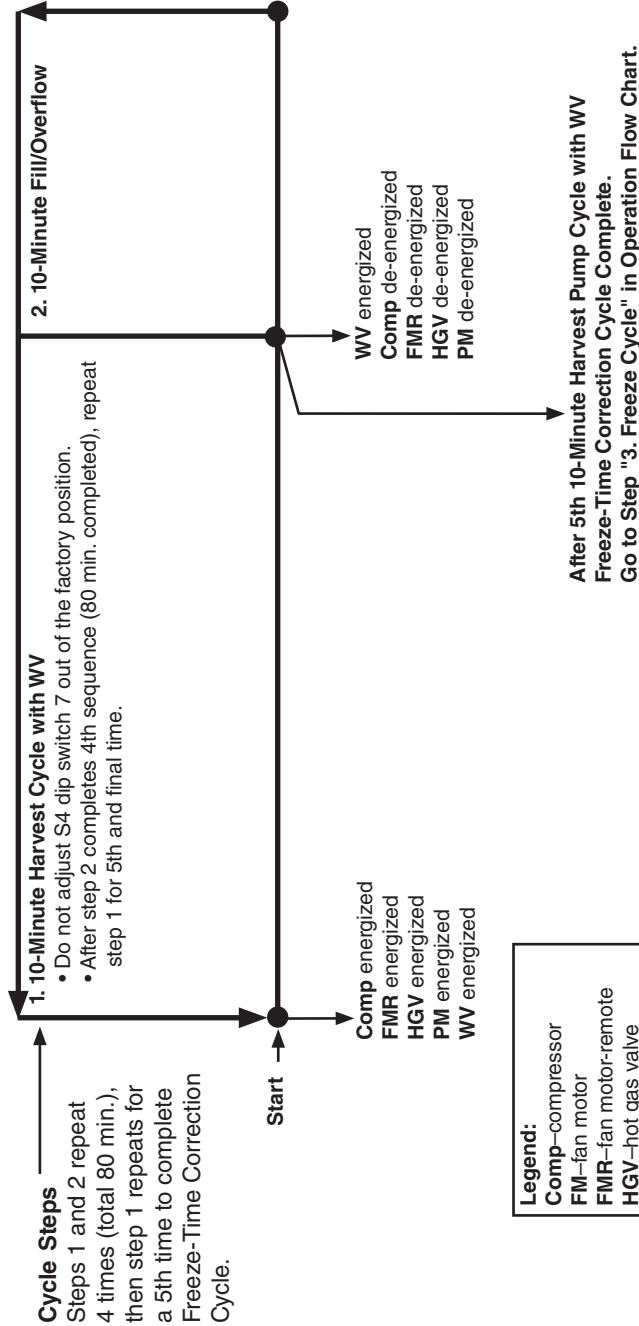

Appliance Cycle Reset and Alarm Reset:
Cycle Reset: Power Supply or Control Switch Turned Off and On again: Appliance turns off, then re-starts at 1.Fill Cycle.
Alarm Reset: CB "ALARM RESET" pressed during or after a freeze-time correction cycle with power supply on: Appliance continues cycle with no interruption or reset. CB red "POWER OK" LED blinking: CB red "POWER OK" LED resets to solid. CB yellow "EXT HARVEST" LED blinking: CB yellow "EXT HARVEST": LED turns off.

B. Service Diagnosis

WARNING

- The appliance should be diagnosed and repaired only by qualified service personnel to reduce the risk of death, electric shock, serious injury, or fire.
- Risk of electric shock. Control switch in "OFF" position does not de-energize all loads. Use extreme caution and exercise safe electrical practices.
- Moving parts (e.g., fan blade) can crush and cut. Keep hands clear.
- Before servicing the appliance, move the control switch to the "OFF" position and turn off the power supply.
- **CHOKING HAZARD:** Ensure all components, fasteners, and thumbscrews are securely in place after the appliance is serviced. Make sure that none have fallen into the dispenser unit/ice storage bin.
- Make sure all food zones in the appliance and dispenser unit/ice storage bin are clean after service.

The diagnostic procedure is a sequence check that allows you to diagnose the electrical system and components. Before proceeding, check for correct installation, proper voltage per nameplate, and adequate water supply. Check CB using the steps in "II.D. Control Board Check." Check dip switch settings to assure that S4 dip switch 3, 4, 7, 8, 9, 10 and S5 dip switch 1 through 5 are in the factory default position. S4 dip switch 1, 2, 5, 6 are cleaning adjustments and the settings are flexible. For factory default settings, see "III.C.1. Default Dip Switch Settings."

Note: • When checking high voltage (115VAC), always choose a white (W) neutral wire to establish a good neutral connection.

- When checking voltage from the CB K1 connector (10 pin connector), pull CB K1 connector out slightly to allow room for multimeter test leads contact. Confirm that the location meets installation requirements:
- The appliance is not intended for outdoor use. Normal operating ambient temperature should be within 45°F to 100°F (7°C to 38°C).
- Allow 6" (15 cm) clearance at rear, sides, and top for proper air circulation and ease of maintenance and/or service should they be required.
- The appliance should not be located in a corrosive environment.

- 1) Turn off the power supply, then access the control box. Move the control switch to the "OFF" position. Clear any ice from BC.
- 2) Check that the 115VAC 10A fuse is good.

1. Diagnosis

- 3) **Power On:** Turn on the power supply, then move the control switch to the "ICE" position. A 5-sec. delay occurs. CB red "POWER OK" LED and CB green "BC CLOSED" LED turn on. If CB yellow "BC OPEN" LED is on (indicating a missing or loose jumper (4A4883G01)), check that the jumper is securely in place. Move ice away from BC bulb. If CB yellow "BC OPEN" LED stays on, see "II.E. Bin Control Check."

Note: • CB red "POWER OK" LED remains on unless the 10.5VAC power supply is interrupted (K2 connector).

- Check CB using the steps in "II.D. Control Board Check."
- Confirm CB green "BC CLOSED" LED is on. If CB yellow "BC OPEN" LED is on, confirm jumper (4A4883G01) is in place on CB K4 red connector.

- a) **Power On Diagnosis:** If CB red "POWER OK" LED is off, confirm 10A fuse is good. Check for 115VAC at control switch #2 (BK) to neutral (W) then at control switch #3 (P) to neutral (W). If 115VAC is present on #2 (BK) and not on #3 (P), replace control switch. If 115VAC is present on control switch #3 (P), check for 115VAC at HPS (P) to neutral (W) then HPS (BK) to neutral (W). If 115VAC is present at HPS (P) and not at HPS (BK), HPS is open. See HPS Diagnosis below. If 115VAC is present at HPS (BK), check for 10.5VAC at CB K2 #1 red (R) wire to CB K2 #2 red (R) wire. If 10.5VAC is not present, check CT continuity. If open, replace CT.
- b) **HPS Diagnosis:** Let refrigeration circuit pressures equalize. If HPS does not reset and pressures are equalized, replace HPS. Check that the condenser coil is not clogged or restricted. If pressures are not equalized, reclaim refrigerant and diagnose refrigeration circuit restriction. Check that there are no restrictions in the refrigeration circuit.
Harvest Cycle: HGV, strainer, or check valve.
Freeze Cycle: FM, FMR, TXV, WRV, HM, LLV, strainer, check valve, drier, and damaged line set or fitting. On water-cooled models, confirm WRV opens in freeze cycle.
- 4) **1-Min. Fill Cycle – LED 4 is on.** WV and X11 relay energize. Water begins to fill the water tank. After 1 min., CB checks for a closed FS. If FS is closed, the harvest cycle begins (X10, X12, X14, Comp, HGV, and FMR energize), Continue to step 5a. If FS is open, WV remains energized through additional 1-min. fill cycles until water enters the water tank and FS closes (low water safety protection during initial start up and at the end of each harvest).
Diagnosis: Check that water enters the water tank. If not, check that the water supply line shut-off valve is open and screens or external filters are clear. Check for 115VAC at CB K1 #6 (O) to neutral (W). If 115VAC is not present, replace CB. If 115VAC is present, and WV does not energize, check for 115VAC at WV. If 115VAC is present, check coil continuity. If open, replace WV. If the water tank fills, but the appliance fails to start harvest (Comp energized), check for open FS. See "II.F. Float Switch Check and Cleaning." If FS is closed and CB fails to start the harvest cycle after 1 min., replace CB.

- 5a) **Initial Harvest Cycle – LEDs 1, 4, and 2 are on.** WV and X11 relay continue. Comp, HGV, X10, X12, and X14 relays energize. CB monitors the warming of the evaporator via the thermistor located on the suction line. When the thermistor reaches 48°F (9°C), CB reads 3.9 kΩ from the thermistor and turns harvest termination over to the harvest timer (S4 dip switch 1 & 2). The harvest timer has settings of 60, 90, 120, and 180 sec. The pump-out timer (S4 dip switch 3 & 4) acts in place of the harvest timer during cycles with a pump-out (S4 dip switch 5). WV and X11 relay are energized during harvest for a maximum of 6 min. or the length of harvest minus 50 sec., whichever is shorter. 50 sec. before harvest terminates, PM energizes. See step 5b below.
- a) **Comp Diagnosis:** Check that evaporator is warming. If not, confirm that Comp energizes. If not, check for 115VAC at CB K1 #1 or #9 (V) to neutral (W). If 115VAC is not present, check for 115VAC at CB K1 #7 or #10 (BK) to neutral (W). If 115VAC is present at #7 or #10 (BK) and not at #1 or #9 (V), replace CB. If 115VAC is present, check for 115VAC at CR solenoid. If 115VAC is present, confirm contacts are closed. If not, replace CR. If CR contacts are closed, check Comp start and run capacitors, Comp start relay, and Comp motor winding.
 - b) **HGV Diagnosis:** If Comp is energized and evaporator is not warming, check that HGV energizes and opens. Check for 115VAC at CB K1 #2 (P) to neutral (W). If 115VAC is not present and LED 2 is on, replace CB. If 115VAC is present, check for 115VAC at HGV coil and check HGV coil continuity. Replace as needed.
 - c) **LLV Diagnosis:** Confirm that LLV is de-energized and closed (not bypassing). If energized, replace CB. If de-energized and bypassing, replace LLV.
 - d) **WRV Diagnosis:** Confirm WRV is not leaking by. If WRV is leaking by, confirm HGV is open and LLV is closed. Next, check for proper refrigerant pressures. If refrigerant pressures are correct, adjust or replace WRV. See "IV.C. Water Regulating Valve Adjustment (water-cooled model)."
 - e) **CCH Diagnosis (remote model):** Confirm X14 relay energizes, de-energizing the CCH.
- 5b) **Harvest Pump Time (Harvest Assist) – LEDs 1, 3, and 2 are on.** When the thermistor reaches 48°F (9°C), CB reads 3.9 kΩ from the thermistor and turns harvest termination over to the harvest timer (S4 dip switch 1 & 2 and S5 dip switch 4). When WV de-energizes, LED 4 turns off, X11 relay de-energizes and LED 3 turns on. PM energizes. Comp, HGV, X10, X12, and X14 relays continue.
- a) **Thermistor Diagnosis:** Place a thermometer on the suction line next to the thermistor. Has it warmed to 48°F (9°C) or warmer? Confirm thermistor status. See "II.G. Thermistor Check."
 - b) **Control Board Diagnosis:** If the thermistor reading is in proper range, dip switch 7 is on, and WV continues, check for 115VAC at CB K1 #6 (O) to neutral (W). If 115VAC is present, and LED 4 is off, replace CB. If LED 3 is on and PM is not energized, check for 115VAC at CB K1 #5 (DBU) to neutral (W). If 115VAC is not present, replace CB.

- c) **Relay Diagnosis:** If 115VAC is present and PM is not energized, check for 115VAC at X10 relay #8 (Y) to neutral (W). If 115VAC is not present on X10 relay #8 (Y), check for 115VAC at X10 relay #4 (P) and X10 relay #6 (Y) to neutral (W) (latching circuit). If 115VAC is present at X10 relay #4 (P) and not at X10 relay #6 (Y), replace X10 relay. If 115VAC is present on X10 relay #8 (Y) and PM is not energized, check for 115VAC at X10 relay #3 (R) and X10 relay #5 (DBU) to neutral (W). If 115VAC is present at X10 relay #5 (DBU) and not at X10 relay #3 (R), replace X10 relay.
- d) **Control Switch Diagnosis:** If 115VAC is present at X10 relay #3 (R), check for 115VAC at control switch #6 (R) to neutral (W). Next, check for 115VAC at control switch #5 (Y) to neutral (W). If 115VAC is present at control switch #6 (R) and not at control switch #5 (Y), check control switch continuity. If contacts are open, replace control switch.
- e) **Pump Motor Diagnosis:** If 115VAC is present at control switch #5 (Y), check PM capacitor and motor winding continuity.
- 5c) **Initial Harvest Cycle Termination Diagnosis:** When the thermistor reaches 48°F (9°C), CB reads 3.9 kΩ from the thermistor and turns harvest termination over to the harvest timer (S4 dip switch 1 & 2 and S5 dip switch 4). Check discharge line temperature. For a thermistor check, see "II.G. Thermistor Check." If 1-min. fill cycle starts after harvest timer terminates, check that FS is clean and operating properly, see "II.F. Float Switch Check and Cleaning." If FS is closed, CB proceeds to the next cycle. If not, replace CB.
- Note: The minimum total time allowed by CB for a complete harvest cycle is based on S5 dip switch 4. Maximum harvest time allowed is 20 min.

6) **Freeze Cycle – LED 1 is on.** Comp, PM, and X14 relay continue. FMR, FM, and LLV energize. HGV, X10, and X12 relays de-energize. Appliance is held in freeze by a 5-min. short cycle protection timer. After 5-min. short cycle protection timer terminates and FS opens, freeze cycle terminates.

Note: PM power supply switches from CB K1 #5 (DBU) in harvest to K1 #4 (R) in freeze.

Slush Control: When the thermistor reaches 36°F (2.2°C), CB reads 5.8 kΩ from the thermistor and de-energizes the PM for 10 sec. (slush control). After 10 sec. CB energizes PM and freeze cycle continues.

a) **Freeze Cycle Diagnosis:** Confirm Comp, PM, and X14 relay continue. Confirm that FMR, FM, and LLV energize. Confirm WRV opens. Next, confirm HGV, X10, and X12 relays de-energize. During the first 5 min. of freeze, confirm evaporator is cooling. If not, confirm WV de-energized (not leaking by), HGV de-energized (not bypassing), FM, FMR, and LLV energize, TXV and HM operate correctly, WRV opens, Comp is efficient, and refrigerant charge is correct. See "VIII.A. Specification and Performance Data Sheets."

b) **Comp and FMR Diagnosis:** If Comp de-energizes once freeze begins, check that appliance has not shut off on HPS ("POWER OK" LED off). If so, check "3)b) HPS Diagnosis." If "POWER OK" LED is on, check for 115VAC at CB K1 #1 (V) or #9 (V) to neutral (W). If 115VAC is not present and LED 1 is on, replace CB.

Comp: If 115VAC is present, check for 115VAC at CR coil. If 115VAC is present, check CR coil and contact continuity. Replace as needed. If CR is okay, check Comp start relay and start and run capacitors. Next, check Comp motor winding continuity. If Comp is energized but evaporator is not cooling, check for an inefficient Comp. See "VIII.A. Specification and Performance Data Sheets."

For FMR, check for 115VAC at the FMR junction box. If 115VAC is not present, check icemaker wiring connections. If 115VAC is present, check for voltage at condenser unit. If 115VAC is not present, check field wiring connections. If 115VAC is present, check FMR capacitor, motor winding, and fan blade for binding.

c) **WV and HGV Diagnosis:** If WV is energized, check for 115VAC at CB K1 #6 (O) to neutral (W). If 115VAC is present after PM energizes in harvest cycle, replace CB. If 115VAC is not present, replace WV (bypassing). If HGV did not de-energize at the end of harvest, check for 115VAC at CB K1 #2 (P) to neutral (W). If 115VAC is present and LED 3 is off, replace CB. If 115VAC is not present, replace HGV (bypassing).

d) **PM Diagnosis:** Confirm water is flowing over evaporator from PM and not WV. If PM de-energizes once freeze begins or fails to energize after 10 sec. (slush control), check for 115VAC at CB K1 #4 (R) to neutral (W). If 115VAC is not present, replace CB. If 115VAC is present and PM is de-energized, check for 115VAC at control switch #6 (R) to neutral (W) and control switch #5 (Y) to neutral (W). If 115VAC is present at control switch #6 (R) and not at control switch #5 (Y), check control switch continuity. Replace as needed. If 115VAC is present at control switch #5 (Y) to neutral (W), check PM capacitor and motor winding continuity.

e) **FM and LLV Diagnosis:** If FM or LLV does not energize, check for 115VAC at CB K1 #3 (BK) to neutral (W). If 115VAC is not present, replace CB. If 115VAC is present: For FM, check capacitor, motor winding, and blade for binding. For LLV, check coil voltage and continuity.

- f) **Refrigerant Pressures, HM, and TXV Diagnosis:** If evaporator is still not cooling, check refrigerant pressures. See "VIII.A. Specification and Performance Data Sheets." Next, check HM operation. If refrigeration pressures are above HM setpoint and HM is bypassing, replace HM. Check TXV for proper operation. Remove TXV bulb and hold it in your hand, refrigerant low-side pressure should rise, place TXV bulb in ice water, refrigerant low-side pressure should drop. A 10 to 15 pound pressure swing between warm and cold conditions indicate a good TXV. If a 10 to 15 pound swing is not present, replace TXV.
- g) **WRV Diagnosis:** WRV is factory set and generally no adjustment is required. If WRV fails to open in freeze, check for proper refrigerant pressures. See "VIII.A. Specification and Performance Data Sheets." If refrigerant pressures are correct and WRV does not open, adjust or replace as needed. See "IV.C. Water Regulating Valve Adjustment (water-cooled models)."
- h) **Freeze Termination Diagnosis:** After 5 min. in freeze, disconnect CB K5 FS connector. 15 sec. later appliance should switch out of the freeze cycle (15 second delay after FS opens before terminating the freeze cycle). If appliance remains in freeze longer than 15 sec. after FS removed, replace CB. If appliance switches with FS removed but would previously not switch out of freeze with FS connected (long freeze - 3 beep alarm), see "II.F. Float Switch Check and Cleaning."

Note: Normal freeze cycle will last 20 to 40 min. depending on model and conditions.

Cycle times and pressures should follow performance data provided in this manual. See "VIII.A. Specification and Performance Data Sheets."

- i) **Short Freeze Cycle Diagnosis:** Confirm water tank fills and overflows during 1 min. fill and harvest cycles. If not, check water supply filters, shut-off valve, WV screen. If water tank empties before 5 min. timer terminates and freeze cycle is short, check that DV is not leaking by or energized (water flowing through DV). If DV is leaking by, remove and clean DV, replace as needed. If water tank is full, see "II.F. Float Switch Check and Cleaning." for erratic operating FS.

- 7) **Pump-Out Cycle – LEDs 1, 3, and 2 are on (10/20 second pump-out).** Timing of the first pump-out is determined by S4 dip switch 5. See the table below.

Control Board Settings		
S4 Dip Switch Setting	Pump-Out Frequency	1st Pump-Out
No. 5		
OFF	Every 10 cycles	After 11th freeze cycle
ON	Every cycle	After 2nd freeze cycle

Comp and X14 relay continue, HGV energizes, FM, FMR, and LLV de-energize.

NOTICE! S4 dip switch 3 & 4 must not be set to 3 off and 4 on. Otherwise, LED 4 turns on energizing WV and X11 relay. Once X10 relay energizes, the DV cannot energize. PM stops for 2 sec., then X12, PM, and DV energize for 10/20 sec. depending on pump-out timer (S4 dip switch 3 & 4) setting. When the pump-out timer terminates, pump-out is complete. The pump-out frequency control (S4 dip switch 5) is factory set, and generally no adjustment is required. However, the pump-out frequency control can be set to have a pump-out occur every cycle, or every 10 cycles. For details, see "III.C.4. Pump-Out Frequency Control (S4 dip switch 5)."

- a) **Pump-Out Diagnosis:** In the freeze cycle before pump-out (see table above), after 5 min. of freeze disconnect CB black K5 connector (FS connector). Check that CB LEDs 1, 3, and 2 are on, PM stops, then re-starts, DV energizes, and water is flowing down the drain through DV.
- b) **CB Diagnosis:** Confirm FMR, FM, and LLV de-energize. If FRM, FM, or LLV are energized with LEDs 1, 3, and 2 on, replace CB. If PM does not stop and re-start and DV does not energize, check that CB LEDs 1, 3, and 2 are on. If not, replace CB. If LEDs 1, 3, and 2 are on and PM and DV do not energize, check for 115VAC at CB K1 #5 (DBU) to neutral (W). If 115VAC is not present, replace CB.
- c) **X10 and X11 Relays Diagnosis:** If 115VAC is present at CB K1 #5 (DBU), check for 115VAC at X10 relay #1 (DBU) to neutral (W). If 115VAC is not present, check that X10 relay is de-energized. If X10 relay is de-energized and 115VAC not present at X10 relay #1 (DBU), replace X10 relay (contacts sticking). If X10 relay is energized, check X11 relay status. If X11 relay is energized, check that S4 dip switch 3 and 4 are not set to 3 on and 4 off positions, if not and X11 is energized, replace CB. If X11 relay is de-energized and X10 relay is energized, replace X11 relay (contacts sticking).
- d) **X12 Relay Diagnosis:** If 115VAC is present at X10 #1 (DBU), check for 115VAC at X12 relay #5 (DBU) to neutral (W) and X12 relay #3 (DBU) to neutral (W). If 115VAC is present at X12 relay #5 (DBU) and not at X12 relay #3 (DBU), check for 115VAC at X12 relay #8 (P) to neutral (W). If 115VAC is present at X12 relay #8 (P) and X12 relay is de-energized, replace X12 relay. If 115VAC is not present, check CB K1 #2 (P) to neutral (W). If 115VAC is not present (HGV de-energized as well), replace CB.

e) **X13 Relay Diagnosis:** If 115VAC is present at X12 terminal #3 (DBU) to neutral and PM and DV are not energized, check for 115VAC at X13 terminal #8 (DBU) to neutral (W). If 115VAC is present and X13 relay is de-energized, replace X13 relay.

(1) **For PM and X13 Relay:** If 115VAC is present at X13 terminal #8 (DBU), check for 115VAC at X13 relay #6 (BK) and X13 relay #4 (Y) to neutral (W). If 115VAC is present at X13 relay #6 (BK) and not at X13 relay #4 (Y), replace X13 relay (contacts sticking open). If 115VAC is present at X13 relay #4 (Y) and PM is not energized, check PM capacitor, motor winding, and impeller for binding.

(2) **For DV and X13 Relay:** If 115VAC is present at X13 terminal #8 (DBU), check for 115VAC at X13 relay #5 (DBU) and X13 relay #3 (W/BU) to neutral (W). If 115VAC is present at X13 relay #5 (DBU) and not at X13 relay #3 (W/BU), replace X13 relay (contacts sticking open). If 115VAC is present at X13 relay #3 (W/BU) and DV is de-energized, check DV coil continuity, make sure the drain line is not clogged and that DV is clean and operating properly.

8) **Normal Harvest Cycle** – Same as the initial harvest cycle. Return to step 5a) above.

Note: Appliance continues to cycle until BC is satisfied or power is switched off.

The appliance always restarts at the 1-min. fill cycle.

2. Shutdown Diagnosis

When the appliance is running, hold ice in contact with the thermostatic bulb. BC switch opens within 10 sec., shutting down the appliance. BC is factory set, and generally no adjustment is required. However, adjustment may be needed in some conditions, particularly at higher altitude locations.

Diagnosis: See "II.E. Bin Control Check." CB red K4 connector must have the jumper in place. When the jumper is in place, the green "BC CLOSED" LED remains on. If the jumper is not in place, yellow "BC OPEN" LED turns on and the icemaker turns off and remains off until the jumper is replaced in its original position.

NOTICE! CB red K4 connector jumper (4A4883G01) must be in place.

3. Freeze-Time Correction Cycle Diagnosis

1) See "II.C. Freeze-Time Correction Cycle (90 min.) (CB: 2A7664-02)."

Legend: **BC**–bin control; **CB**–control board; **Comp**–compressor; **CR**–compressor relay; **CT**–control transformer; **CV**–cleaning valve; **DV**–drain valve; **FMRs**–fan motor remote; **FS**–float switch; **HGVs**–hot gas valve; **HM**–headmaster (C.P.R.); **HPS**–high-pressure switch; **LLVs**–liquid line valve; **PM**–pump motor; **TXV**–thermostatic expansion valve; **WV**–inlet water valve

C. Freeze-Time Correction Cycle (90 min.) (CB:2A7664-02)

Freeze-Time Correction function is enabled when S4 Dip Switch 7 is in the "ON" position and initiates when the minimum and maximum freeze times have exceeded differential parameters. Freeze-time correction timer and count starts at the beginning of the 2nd freeze cycle after startup from power off condition. Freeze-time correction timer and count continues and retains its freeze-time correction timer and count during a BC off cycle and resumes its freeze-time correction timer and count on the 2nd freeze cycle after BC restart. If freeze-time differential is exceeded (see table below), freeze-time correction cycle starts and CB red "POWER OK" LED blinks. When freeze-time correction cycle occurs 3 or more times within a 36 hour period, CB yellow "EXT HARVEST" LED blinks with CB red "POWER OK" LED. Appliance starts in freeze cycle after a freeze-time correction cycle. To reset CB LEDs, press ALARM RESET button on CB with power on. CB resets LEDs and appliance continues cycle without interruption.

- 1) **Freeze Time Differential Initiation:** CB starts monitoring freeze times on the second freeze time. After 3 freeze cycles (4th total), CB begins to compare minimum and maximum freeze time cycles. Every freeze cycle time after the first freeze cycle time is added to the freeze time list. Minimum and maximum freeze time differential comparisons begin on the third cycle and are monitored up to 10 cycles. On the 11th cycle the first freeze cycle time is dropped to maintain the 10 maximum number of cycles.

Example: After 8 cycles (excluding first cycle), if the differential between the shortest cycle (minimum) and the longest cycle (maximum) is equal to or greater than 427 sec. a freeze-time correction cycle is initiated:

Number of Freeze Cycles	Differential Value in Sec.
3	254
4	309
5	349
6	380
7	406
8	427
9	446
10	462

2) **Freeze-Time Correction Sequence:**

First occurrence within 36 hr., minimum and maximum freeze times have exceeded differential parameters. CB "POWER OK" LED starts blinking. Freeze-Time Correction Cycle starts.

Second occurrence within 36 hr., minimum and maximum freeze times have exceeded differential parameters. If not reset, CB "POWER OK" LED continues blinking. If reset from first occurrence, CB "POWER OK" LED starts blinking. Freeze-Time Correction Cycle starts.

Third occurrence within 36 hr. minimum and maximum freeze times have exceeded differential parameters. CB yellow "EXT HARVEST" LED starts blinking. Also, If not reset, CB "POWER OK" LED continues blinking. If reset, CB "POWER OK" LED starts blinking. Freeze-Time Correction Cycle starts.

Total freeze-time correction cycle last for 90 min. At the end of 80 min., the final step initiates and final Harvest Pump Time (Harvest Assist) with WV (10-min.) starts.

Once the final Harvest Pump Time (Harvest Assist) with WV (10-min.) terminates (90 min. complete), normal freeze cycle begins.

2a) **10-Min. Harvest Pump Time (Harvest Assist) with WV:** CB "POWER OK" LED blinking. CB LEDs 1, 4, 3, and 2 are on and Comp, FMR, HGV, PM, and WV energize. 10-min. timer starts. Once 10-min. timer terminates, CB LEDs 1, 3, and 2 turn off and Comp, FMR, HGV, and PM de-energize. WV continues.

2b) **10-Min. Fill:** CB LED 4 on and WV energized. 10-min. timer starts.

2c) **Final 10-Min. Harvest Pump Time (Harvest Assist) with WV:** CB "POWER OK" LED blinking. Once 10-min. timer terminates, CB LEDs 1, 4, 3, and 2 are on and Comp, FMR, HGV, and PM energizes. WV continues. 10-min. timer starts. Once 10-min. timer terminates, normal freeze cycle begins. CB LED 1 on and Comp, FMR, and PM continue. HGV and WV de-energize.

Note: After 3rd Freeze-Time Correction Cycle in 36 hours, CB signals with blinking CB yellow "EXT HARVEST" LED. Appliance continues normal operation.

CB "POWER OK" LED and CB yellow "EXT HARVEST" LED continue blinking in normal operation sequence.

3) **Appliance Cycle Reset and CB Alarm Reset:**

Cycle Reset: Power supply or control switch turned off and on again: Appliance turns off, then re-starts at 1.Fill Cycle.

Alarm Reset: CB "ALARM RESET" pressed during or after a freeze-time correction cycle with power supply on: Appliance continues cycle with no interruption or reset.

CB red "POWER OK" LED blinking: CB red "POWER OK" LED resets to solid.

CB yellow "EXT HARVEST" LED blinking: CB yellow "EXT HARVEST: LED turns off.

Legend: **BC**—bin control; **CB**—control board; **Comp**—compressor; **CR**—compressor relay; **CT**—control transformer; **CV**—check valve; **FM**—fan motor; **FMR**—fan motor remote; **FS**—float switch; **HGV**—hot gas valve; **HM**—headmaster (C.P.R.); **HPS**—high-pressure switch; **LLV**—liquid line valve; **PM**—pump motor; **TXV**—thermostatic expansion valve; **WRV**—water regulating valve; **WV**—inlet water valve

D. Control Board Check

Before replacing CB that does not show a visible defect and that you suspect is bad, always conduct the following check procedure. This procedure will help you verify your diagnosis.

Alarm Reset: If CB is in alarm (beeping), press the "ALARM RESET" button on CB while CB is beeping. **WARNING! Risk of electric shock. Care should be taken not to touch live terminals.** Once reset, the icemaker starts at the 1-minute fill cycle. For audible alarm information, see "III.B. LED Lights and Audible Alarm Safeties."

- 1) Check the dip switch settings to assure that S4 dip switch 3, 4, 7, 8, 9, 10 and S5 dip switch 1 through 5 are in the factory default position. S4 dip switch 1, 2, 5, and 6 are cleaning adjustments and the settings are flexible. For factory default settings, see "III.C.1. Default Dip Switch Settings."
- 2) Move the control switch to the "ICE" position. If the red "POWER OK" LED is on, control voltage is good, continue to step 3. If the "POWER OK" LED is off, check CT secondary circuit. CT output is 10.5VAC at 115VAC primary input. If the secondary circuit has proper voltage and the red LED is off, replace CB.

If the secondary circuit does not have proper voltage (10.5VAC), check CT primary circuit. Check for 115VAC at control switch terminal #2 (BK) and control switch terminal #3 (P) to neutral (W). If 115VAC is present at control switch terminal #2 (BK) and not at control switch terminal #3 (P), replace control switch. If 115VAC is present at control switch terminal #3 (P), check for 115VAC at HPS (BK) to neutral (W). If 115VAC is not present, see "B.1.3)b) HPS Diagnosis." If 115VAC is present check CT coil continuity. Replace as needed. For additional checks, see "II.I.1. No Ice Production."

- 3) The "OUTPUT TEST" button provides a relay sequence test. Make sure the control switch is in the "ICE" position, then press the "OUTPUT TEST" button. For the correct lighting sequence, see the table below. Note that the order of the LEDs from the outer edge of the control board is 1, 4, 3, 2. Components (e.g., compressor) cycle during the test.

Control Board	Correct LED Lighting Sequence
	1, 4, 3, 2

Following the test, the icemaker begins operation at the 1-minute fill cycle. If the LEDs do not light as described above, replace CB.

- 4) To verify voltage output from CB to the components, slide the CB K1 connector out far enough to allow multimeter lead contact. With the icemaker in the cycle to be tested, check output voltage from the corresponding pin on CB K1 connector to a neutral (W) wire. If output voltage is not found and the appropriate LED is on, replace CB.

Legend: **CB**—control board; **CT**—control transformer

E. Bin Control Check

BC shuts down the icemaker within 10 sec. when ice contacts the thermostatic bulb, regardless of the cycle at activation.

NOTICE

When the ambient temperature is below 45°F (7°C), BC opens and shuts down the appliance even if the ice storage bin is empty. When BC is set in the prohibited range, the appliance operates continuously even if the ice storage bin is filled with ice. Setting in the prohibited range may result in severe damage to the appliance.

BC is factory set, and generally no adjustment is required. However, adjustment may be needed in some conditions, particularly at higher altitude locations.

Note: On thermostatic bin control models, a jumper (4A4883G01) must be placed on CB red K4 connector. Otherwise, CB yellow "BC OPEN" LED is on and appliance will not start.

To check BC, follow the steps below.

- 1) Turn off the power supply.
- 2) Remove the front panel, then move the control switch to the "OFF" position.
- 3) Remove the control box cover, then clear any ice away from BC bulb.
- 4) Disconnect BC wires from BC switch.
- 5) Hold your hand around the bulb to warm it up.
- 6) Check for continuity across BC switch. If closed, continue to step 6. If open, adjust or replace BC.
- 7) With the multimeter test leads still in place, hold ice on BC bulb to lower the temperature. Within 10 sec., BC switch should open. If it remains closed, adjust or replace BC.

Legend: **BC**—bin control

F. Float Switch Check and Cleaning

FS is used to determine that there is sufficient water in the water tank after the 1-minute fill cycle and after each harvest cycle. FS is also used to determine that the appropriate volume of water has been converted into ice before switching out of the freeze cycle. No adjustment is required. **Note:** FS is not part of refill operation.

1. Float Switch Check

To check FS, follow the steps below.

- 1) Turn off the power supply.
- 2) Remove the front panel.
- 3) Place the control switch in the "SERVICE" position. Then place the service switch in the "DRAIN" position.
- 4) Replace the front panel in its correct position, then turn on the power supply for 2 minutes.
- 5) Turn off the power supply.
- 6) Remove the front panel, then move the control switch to the "OFF" position.
- 7) Remove the top and right side panels.
- 8) Remove the control box cover, then disconnect FS connector from CB K5 (black) connector.
- 9) Check for continuity across FS leads. With the water tank empty, FS should be open. If open, continue to step 10. If closed, follow the steps in "II.F.2. Float Switch Cleaning." After cleaning FS, check it again. Replace if necessary.
- 10) Reconnect FS connector to CB K5 (black) connector, then replace the control box cover, right side, and top panels in their correct positions.
- 11) Move the control switch to "ICE" position. Replace the front panel.
- 12) Turn on the power supply.
- 13) As water fills the water tank, FS contacts should close. After 1 minute, the 1-minute fill cycle should end and the initial harvest cycle should begin.
- 14) Once the harvest cycle starts, turn off the power supply.
- 15) Remove the front panel, then move the control switch to the "OFF" position.
- 16) Remove the top and right side panels.
- 17) Remove the control box cover, then disconnect FS connector from CB K5 (black) connector.
- 18) Check for continuity across FS leads. With the water tank full, FS should be closed. If FS is closed and the icemaker will not switch from the 1-minute fill cycle to the initial harvest cycle, replace CB.
- 19) If open, confirm that the water tank is full. If the water tank is not full, check the water supply, water filters, and fill/refill water valve. If the water tank is full, follow the steps in "II.F.2. Float Switch Cleaning." After cleaning FS, check it again. Replace if necessary.
- 20) Reconnect FS connector to CB K5 (black) connector, then replace the control box cover, right side, and top panels in their correct positions.

- 21) Move the control switch to the "ICE" position.
- 22) Replace the front panel in its correct position.
- 23) Turn on the power supply to start the automatic icemaking process.

Legend: **CB**—control board; **FS**—float switch

2. Float Switch Cleaning

Depending on local water conditions, scale may build up on FS. Scale can cause FS to stick. In this case, FS should be cleaned.

- 1) Turn off the power supply.
- 2) Remove the front panel.
- 3) Place the control switch in the "SERVICE" position. Then place the service switch in the "DRAIN" position.
- 4) Replace the front panel in its correct position, then turn on the power supply for 2 minutes.
- 5) Turn off the power supply.
- 6) Remove the front, top, and right side panels, then move the control switch to the "OFF" position.
- 7) Disconnect the vent tube and the flush tube from the top of FS housing, then remove FS assembly. Remove the rubber boot from the bottom of FS assembly. See Fig. 1.
- 8) Remove the retainer rod from the bottom of FS assembly, then remove the float. Be careful not to bend the retainer rod excessively when removing it.
- 9) Wipe down FS assembly's housing, shaft, float, and retainer rod with a mixture of 1 part Hoshizaki "Scale Away" and 25 parts warm water. Clean the inside of the rubber boot and hose with cleaning solution. Rinse the parts thoroughly with clean water.
- 10) Reassemble FS assembly and replace it and the rubber boot in their correct positions. Reconnect the vent tube and the flush tube.
- 11) Replace the right side and top panels in their correct positions.
- 12) Move the control switch to the "ICE" position.
- 13) Replace the front panel in its correct position.
- 14) Turn on the power supply to start the automatic icemaking process.

Legend: **CB**—control board; **FS**—float switch

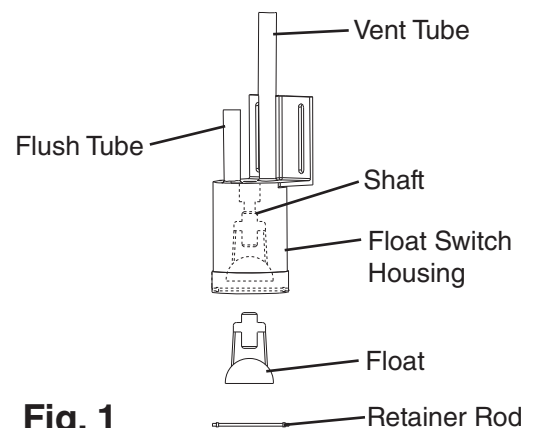

Fig. 1

G. Thermistor Check

To check thermistor resistance, follow the steps below.

- 1) Turn off the power supply.
- 2) Remove the front panel, then move the control switch to the "OFF" position.
- 3) Remove the top and right side panels, then remove the control box cover.
- 4) Remove the thermistor.
- 5) Immerse the thermistor sensor portion in a glass containing ice and water for 2 or 3 minutes.
- 6) Disconnect the thermistor connector from CB K3 (white) connector and check resistance between thermistor leads. Normal range is 4.7 to 6.2 k Ω . If outside the normal range, replace the thermistor. See "IV.B. Component Service Information." If within the normal range, continue to next step.
- 7) Replace the thermistor in its correct position. See "IV.B. Component Service Information."
- 8) Reconnect the thermistor connector to CB K3 (white) connector.
- 9) Replace the control box cover, right side, and top panels in their correct positions.
- 10) Move the control switch to the "ICE" position.
- 11) Replace the front panel in its correct position.
- 12) Turn on the power supply.
- 13) Once the harvest cycle starts (Comp energizes), begin timing the harvest cycle.
- 14) The harvest timer and harvest cycle should terminate within 2 to 5 minutes. If the harvest cycle does not terminate within 2 to 5 minutes, replace CB.

Legend: **CB**—control board; **Comp**—compressor

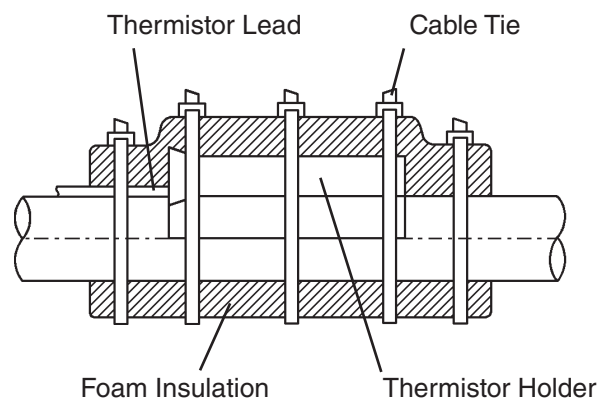

Fig. 2

H. Switches

Two control switches are used to control operation. These switches are referred to as the "control switch" and the "service switch" and are located on the control box.

1. Control Switch

The control switch has three positions: "OFF" for power off, "ICE" for icemaking, and "SERVICE" to activate the service switch. **WARNING! Moving control switch to "OFF" position does not de-energize all components.**

2. Service Switch

When the control switch is in the "SERVICE" position, the control switch supplies power to the service switch and water pump. The machine is in service mode. The service switch has three positions: "DRAIN," "CIRCULATE," and "WASH." See the information below for details of each function.

Note:

1. When the service switch is activated, power is supplied to the water pump in all three positions.
2. When the control switch is in the "OFF" position or in the "ICE" position, the service switch has no power and can be left in any position.

a) **DRAIN**

This appliance utilizes a pump-out drain system. When the service switch is active and placed in the "DRAIN" position, power is supplied to the pump, service relay, and drain valve.

b) **CIRCULATE**

When the service switch is active and placed in the "CIRCULATE" position, power is supplied to the water pump only. This operation can be used to circulate cleaner for extended periods of time over the outside surface of the evaporator.

c) **WASH**

This appliance utilizes a solenoid operated wash (bypass) valve. When the service switch is active and placed in the "WASH" position, power is supplied to the pump and wash valve. This operation is used to circulate cleaner and sanitizer over both the inside and outside of the evaporator.

I. Diagnostic Tables

1. No Ice Production

No Ice Production - Possible Cause	
1. Power Supply	a) Off, blown fuse, or tripped breaker.
	b) Not within specifications.
2. Thermostatic Bin Control See "II.E. Bin Control Check"	a) Engaged with bin filled with ice.
	b) Ambient temperature too cool.
	c) Set too warm.
	d) Bulb out of position.
	e) Open contacts, defective.
3. Fuse (Control Box)	a) Blown.
4. Control Switch	a) In "OFF" or "SERVICE" position.
	b) Bad contacts.
5. High-Pressure Switch	a) Dirty condenser.
	b) Fan motor not operating.
	c) Refrigerant overcharged.
	d) Bad contacts.
	e) Refrigerant lines or components plugged.
6. Control Transformer (115VAC/10.5VAC)	a) Coil winding open or shorted.
7. Control Board See "II.D. Control Board Check"	a) In alarm.
	b) Yellow "BC OPEN" LED on: Jumper loose or missing on models with BC.
	c) Defective.
8. Water Supply	a) Water supply off or improper water pressure.
	b) External water filters clogged.
9. Inlet Water Valve	a) Screen or orifice clogged.
	b) Coil winding open.
	c) Water valve open in freeze cycle.
10. Float Switch See "II.F. Float Switch Check and Cleaning"	a) Float does not move freely.
	b) Defective.
11. Compressor	a) Compressor relay contacts bad or coil winding open.
	b) Start capacitor or run capacitor defective.
	c) Internal protector open.
	d) Start relay contacts bad or coil winding open (single phase).
	e) Compressor defective.
12. Hot Gas Valve	a) Closed in harvest cycle.
	b) Open in freeze cycle.
13. Thermistor See "II.G. Thermistor Check"	a) Loose, disconnected, or defective.
14. Pump Motor	a) Motor winding open.
	b) Bearing worn out or locked rotor.
	c) Defective capacitor.

No Ice Production - Possible Cause	
15. Thermostatic Expansion Valve	a) Bulb loose.
	b) Operating erratically.
16. Liquid Line Valve	a) Closed in freeze cycle.
	b) Open in harvest cycle.
17. Fan Motor/Fan Motor-Remote	a) Motor winding open.
	b) Bearing worn out or locked rotor.
	c) Defective capacitor.
18. Water System	a) Water leaks causing short freeze time.

2. Low Ice Production

Low Ice Production - Possible Cause	
1. Appliance in Freeze-Time Correction Cycle	a) See "II.C.Freeze-Time Correction Cycle."
Long Harvest Cycle	
1. Evaporator	a) Scaled up.
2. Spray Tubes and/or Spray Guides	a) Dirty.
	b) Out of position.
3. Refrigerant Charge	a) Low.
4. Water Supply	a) Low water pressure.
	b) External water filters clogged.
	c) Insufficient water line size. Minimum 1/4" Nominal ID (6 mm Nominal OD in the EU) water tubing or equivalent.
	d) Too cold.
5. Control Board See "II.D. Control Board Check"	a) Thermistor connection loose (K3).
	b) Defective.
6. Thermistor See "II.G. Thermistor Check"	a) Loose, disconnected, or defective.
7. Hot Gas Valve	a) Erratic or closed.
8. Inlet Water Valve	a) Screen or orifice clogged.
9. Compressor	a) Inefficient or off.
10. Liquid Line Valve	a) Erratic or open.
11. Thermostatic Expansion Valve	a) Defective.
Long Freeze Cycle	
1. Evaporator	a) Scaled up, dirty.
2. Float Switch See "II.F. Float Switch Check and Cleaning"	a) Scaled up, dirty.
	b) Float sticking.
	c) Defective switch.
3. Inlet Water Valve	a) Leaking by.
4. Hot Gas Valve	a) Erratic or open.
5. Condenser	a) Clogged.
6. Control Board See "II.D. Control Board Check"	a) Float switch connection loose (K5).
	b) Defective.
7. Refrigerant Charge	a) Low.

Low Ice Production - Possible Cause	
8. Thermostatic Expansion Valve	a) Bulb loose.
	b) Defective.
9. Compressor	a) Inefficient or off.
10. Pump Motor	a) RPM too slow.
11. Liquid Line Valve	a) Erratic or restricted.
12. Headmaster (C.P.R.) (remote models)	a) Not bypassing.

3. Freeze-Up

Defrost and clean the icemaker prior to diagnosing freeze-up. Fill out a freeze-up checklist. See "II.J. Freeze Up Check List," the Hoshizaki America Technician's Pocket Guide, or contact your local distributor for a copy of the freeze-up checklist.

Freeze-Up - Possible Cause	
Harvest Cycle	
1. Evaporator	a) Scaled up.
	b) Damaged.
2. Cube Guides	a) Out of position.
	b) Damaged.
3. Spray Tubes and/or Spray Guides	a) Dirty.
	b) Out of position.
4. Water Supply	a) Low water pressure.
	b) External water filters clogged.
	c) Insufficient water line size. Minimum 1/4" Nominal ID (6 mm Nominal OD in the EU) copper water tubing or equivalent.
5. Inlet Water Valve	a) Screen or orifice clogged.
	b) Defective.
6. Float Switch See "II.F. Float Switch Check and Cleaning"	a) Dirty, sticking.
	b) Defective.
7. Refrigerant Charge	a) Low.
8. Control Board See "III.C. Settings and Adjustments" and "II.D. Control Board Check"	a) Harvest timer (S4 dip switch 1 & 2) set too short.
	b) Harvest pump timer (S4 dip switch 7) not in factory default position.
	c) Defective.
9. Bin Control See "II.E. Bin Control Check"	a) Bulb out of position.
	b) Defective.
10. Thermistor See "II.G. Thermistor Check"	a) Loose, disconnected, or defective.
11. Thermostatic Expansion Valve	a) Defective.
12. Hot Gas Valve	a) Closed or restricted.
13. Liquid Line Valve	a) Open.

Freeze-Up - Possible Cause	
Freeze Cycle	
1. Evaporator	a) Scaled up.
	b) Damaged.
2. Spray Tubes and/or Spray Guides	a) Dirty.
	b) Out of position.
3. Refrigerant Charge	a) Low.
4. Control Board See "II.D. Control Board Check"	a) Freeze timer (S4 dip switch 9 & 10) set incorrectly.
	b) Defective.
5. Inlet Water Valve	a) Leaking by.
6. Float Switch See "II.F. Float Switch Check and Cleaning"	a) Float does not move freely.
	b) Defective.
7. Pump Motor	a) RPM too slow.
	b) Impeller damaged.
8. Thermostatic Expansion Valve	a) Bulb loose or defective.
9. Liquid Line Valve	a) Restricted.
10. Headmaster (C.P.R.) (remote models)	a) Not bypassing.

J. Freeze-Up Check List

Freeze-Up Check List
Please Complete When Diagnosing a Freeze-Up, Refrigerant Leak, or Low Charge
 Technical Support Fax #: 770-487-3360
 Make Copies And Use As Needed

Model # _____ **Serial #** _____ **Install Date** _____ **Freeze-Up Date** _____

List model and manufacture of bin or dispenser _____.

Date appliance was last cleaned: _____.

Freeze-Up Defrost

YES NO

- 1) After defrosting, was the appliance leak checked?
- 2) Were any leaks found?
If so where? _____.
- 3) Was any refrigerant added to the unit?
If so, how much? _____.

Set Up

- 4) Is the appliance stand alone?
- 5) Is water line independent?
- 6) Is water line correct size? If not _____,"
3/8" Nominal ID Copper Water Tubing or Equivalent.
- 7) What is water pressure? _____.
Water Temperature _____.
- 8) Does appliance have any water filtration?
If yes please list the following:
Filter brand _____.
Model _____.
Filter pressure gauge reading during the fill cycle _____.
Date filter was last replaced? _____.
GPM or LPM flow rate of filter system? _____.
- 9) Ambient temperature at appliance? _____.
At remote condenser (if applicable)? _____.

Appliance Status

- 10) Is the appliance and/or float switch dirty?
- 11) List the S4 (1-10) and S5 (1-5) DIP switch settings.
S4: 1 ___ 2 ___ 3 ___ 4 ___ 5 ___ 6 ___ 7 ___ 8 ___ 9 ___ 10 ___
S5: 1 ___ 2 ___ 3 ___ 4 ___ 5 ___
- 12) Is DIP switch number 7 ON (harvest pump time (harvest assist) all models and freeze-time correction models with control board 2A7664-02?
- 13) Is the cube guide positioned correctly?
- 14) Are the evaporator separators positioned properly?
- 15) Is the thermistor properly mounted, tight, and insulated?
- 16) Is the TXV bulb properly mounted, tight, and insulated?
- 17) Are splash guards in place?

Appliance Operation

YES NO

- 18) Does the water tank fill and overflow?
60-90 sec. Note: Larger models may take up to 120 seconds to overflow when empty.
- 19) If NO in step 18, is water flow 5GPM for larger?

Fill

Harvest

- 20) Is the hot gas valve opening?
- 21) Is harvest pump time (harvest assist) utilized (S4 dip switch 7)?
- 22) Is hot gas valve opening in harvest?
- 23) Does water valve close completely when deenergized?
- 24) What was length of harvest? _____.

Freeze

- 25) Is pump motor energized in freeze cycle except during 10-sec. slush control. If activated (S5 dip switch 5 on)?
- 26) Water-cooled condenser outlet temperature 5-min. into freeze? _____°F.
- 27) What was length of freeze? _____.
- 28) Is the cube size consistent from inlet to outlet of evaporator?
- 29) Is ice still dropping when next freeze cycle starts?
- 30) What is the ice drop weight? _____.
- 31) What is head pressure?
Freeze _____ Harvest _____.
(Freeze pressure should be taken 5 minutes into the cycle).
- 32) What is suction pressure?
Freeze _____ Harvest _____.
(Freeze pressure should be taken 5 minutes into the cycle).
- 33) Did appliance shutdown within 10 seconds when ice contacts the bin controls thermostatic bulb?

Freeze-Time Correction Operation - Control Board 2A7664-02

- 34) Has Freeze-Time Correction been activated? ("POWER OK" LED blinking).
- 35) Has moer than 1 Freeze-Time Correction been activated? (POWER OK" LED and "EXT HARVEST" LED blinking).

Note: Make copies of this form and use it when diagnosing a freeze up condition. Submit a completed copy of the checklist along with the freeze-up labor claim form.

III. Controls and Adjustments

- A Hoshizaki exclusive control board is employed in KML series appliances.
- All models are pretested and factory adjusted.
- For a control board check procedure, see "II.D. Control Board Check."

<i>NOTICE</i>
<ul style="list-style-type: none">• Fragile, handle very carefully.• The control board contains integrated circuits, which are susceptible to failure due to static discharge. It is especially important to touch the metal part of the icemaker when handling or replacing the control board.• Do not touch the electronic devices on the control board or the back of the control board.• Do not change wiring and connections. Do not misconnect K3 WHITE, K4 RED, and K5 BLACK, because the same connector is used for the thermistor, mechanical bin control, K4 jumper, and float switch.• Do not short out power supply to test for voltage.• Always replace the whole control board assembly if it goes bad.

A. Control Board Layout

"J" Control Board

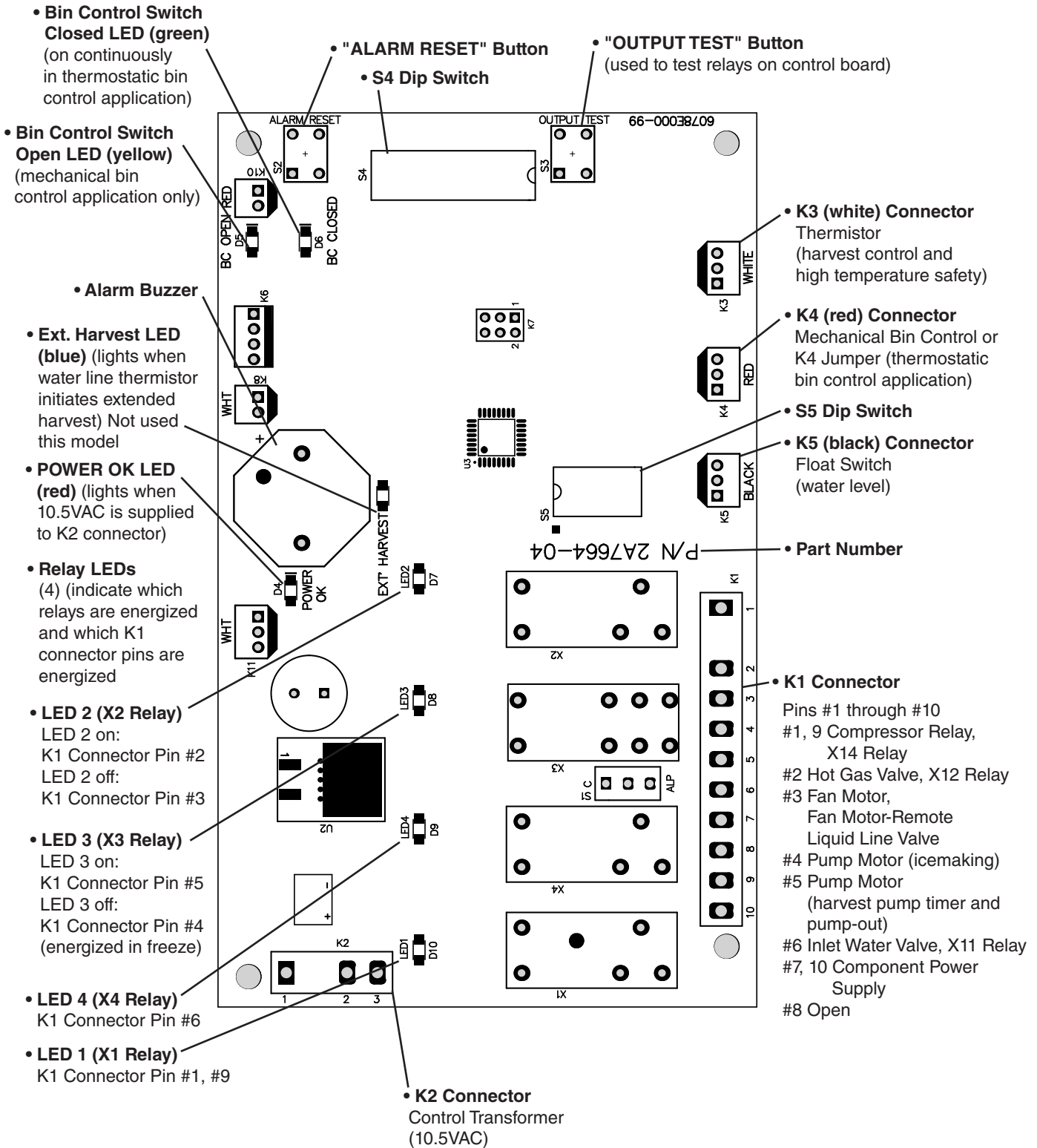

Control Board	
Part Number	2A7664-04

B. LED Lights and Audible Alarm Safeties

Beep occurs and red "POWER OK" LED turns on when control switch is moved to "ICE" position.

Sequence

Green LEDs 1 through 4 turn on and sequence from initial startup as listed in the table below. Order of green LEDs from the outer edge of control board is 1, 4, 3, 2.

Sequence Step	LED	Energized Components	Time LEDs are On	
			Min.	Max.
1-Minute Fill Cycle	4	WV		
Harvest Cycle	1, 4, 2	Comp, FM*, FMR, HGV, WV	1 minute	20 minutes
Harvest Pump Time (harvest assist)	1, 3, 2	Comp, FM*, FMR, HGV, PM	0 seconds	50 seconds
Freeze Cycle	1	Comp, FM/FMR, PM, LLV	5 minutes	freeze timer setting
Anti-Slush Control	1, 3	Comp, FM/FMR, LLV	If S5 dip switch 5 on, PM off 10 sec. when thermistor at 36°F (2.2°C)	
Pump-Out Cycle	1, 4 [†] , 3, 2	Comp, FM*, FMR, HGV, PM, WV [†] , DV	10 seconds	20 seconds

*FM energized if on K1 Connector Pin #9; [†]pump-out timer setting

Alarms

Type	Alarm	Notes
1 Beep	High Evaporator Temp. (temperature > 127°F) (53°C)	Check for harvest problem (stuck HGV or relay), hot water entering unit, stuck HM, or shorted thermistor.
2 Beep	Harvest Backup Timer (harvest > 20 min. for two cycles in a row)	Check thermistor (open), HGV not opening, TXV or LLV leaking by, low charge, inefficient Comp, or WRV leaking by.
3 Beep	Freeze Timer (freeze > freeze timer setting for two cycles in a row)	Check FS stuck closed (up), WV leaking by, HGV leaking by, PM not pumping, TXV defective, LLV not opening, low charge, HM not bypassing, or inefficient Comp.
LED Blink	Freeze-Time Correction (CB-2A7664-02) (maximum freeze time differential exceeded)	Red POWER OK LED blinks. After 3 freeze-time correction cycles in 36 hours, yellow EXT HARVEST LED also blinks. Fill out freeze-up checklist. See "II.J. Freeze-Up Check List."
To reset above safeties, press "ALARM RESET" button with power supply on.		
6	Low Voltage (92Vac±5% or less)	Red LED turns off if voltage protection operates. Control voltage safeties automatically reset when voltage is corrected.
7	High Voltage (147Vac±5% or more)	

Legend: **CB**—control board; **Comp**—compressor; **FM**—fan motor; **FMR**—fan motor remote; **FS**—float switch; **HGV**—hot gas valve; **HM**—headmaster (C.P.R.); **LLV**—liquid line valve; **PM**—pump motor; **TXV**—thermostatic expansion valve; **WRV**—water regulating valve; **WV**—inlet water valve

C. Settings and Adjustments

NOTICE

Dip switches are factory set. Failure to maintain factory settings may adversely affect performance and warranty coverage. For more information, contact your Hoshizaki Service Center.

1. Default Dip Switch Settings

The dip switches are factory-adjusted to the following positions for the control board:

S4 Dip Switch No.	1	2	3	4	5	6	7	8	9	10
KML-325M_J										
KML-500M_J	OFF	OFF	OFF	OFF	OFF	OFF	ON	OFF	OFF	OFF
KML-700M_J										

S5 Dip Switch (Do Not Adjust) "J" Control Board					
Dip Switch No.	1	2	3	4	5
KML-325M_J					
KML-500M_J		OFF			ON
KML-700M_J					

S4 Dip Switch

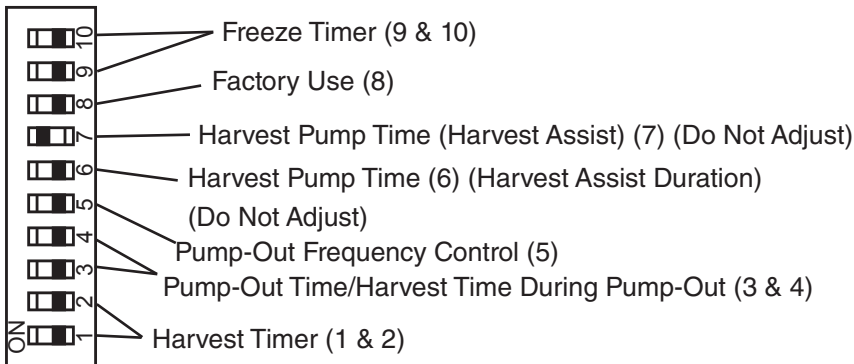

S5 Dip Switch (Do Not Adjust)

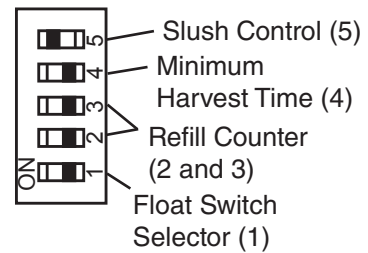

2. Harvest Time (S4 dip switch 1 & 2)

The harvest timer starts counting when the thermistor reaches 48°F (9°C) at the evaporator outlet and the control board reads 3.9 kΩ from the thermistor. The harvest timer is factory set, and generally no adjustment is required. However, a setting longer than the factory setting may be advised in cases where the drain provided at harvest needs to be prolonged for extra cleaning. Before changing this setting, contact Hoshizaki Technical Support at 1-800-233-1940 for recommendations. Keep in mind that setting the harvest timer to a longer setting decreases 24-hour production. Note that the pump-out timer (S4 dip switch 3 & 4) acts in place of the harvest timer during cycles with a pump out. For details, see "III.C.3. Pump-Out Timer (S4 dip switch 3 & 4)."

Note: On models with a pump-out every cycle, the harvest timer is only relevant during the initial harvest cycle since a pump out occurs every cycle thereafter.

S4 Dip Switch Setting		Time (sec.)	
No. 1	No. 2	S5-4 OFF	S5-4 ON
OFF	OFF	60	30
ON	OFF	90	45
OFF	ON	120	60
ON	ON	180	75

3. Pump-Out Time/Harvest Time During Pump-Out (S4 dip switch 3 & 4)

NOTICE

- Do not adjust 3 off and 4 on. Drain valve does not energize in this setting.

When a pump-out is called for, the pump motor stops for 2 sec. After 2 sec. the drain valve and pump motor energize. Water is removed from the bottom of the water tank and sent down the drain. The pump-out drains the water tank for the time determined by the pump-out timer. The pump-out timer also acts in place of the harvest timer during cycles with a pump-out. The pump-out timer is factory set, and generally no adjustment is required. However, where water quality is bad and the icemaker needs a longer pump-out time, the pump-out timer can be adjusted. The pump-out timer control can be set to pump-out for 10 or 20 sec.

S4 Dip Switch Setting		Time (sec.)			Inlet Water Valve	
No. 3	No. 4	T1	T2		S5-4 OFF	S5-4 ON
			S5-4 OFF	S5-4 ON		
OFF	OFF	10	150	100	Closed	Closed
ON	OFF	10	180	130	Closed	Closed
OFF	ON	10	120	70	Open	Closed
ON	ON	20	180	180	Closed	Closed

T1: Time to drain the water tank

T2: Harvest timer at pump out

4. Pump-Out Frequency Control (S4 dip switch 5)

The pump-out frequency control is factory set to drain the water tank every 10 cycles. Generally no adjustment is required. However, where water quality is bad and the icemaker needs a pump-out more often, the pump-out frequency can be adjusted. The pump-out frequency control can be set to have a pump-out occur every cycle, or every 10 cycles.

The first pump-out is dependent on S4 dip switch 5. See the table below.

S4 Dip Switch Setting	Pump-Out Frequency	1st Pump-Out
No. 5		
OFF	Every 10 cycles	After 11th freeze cycle
ON	Every cycle	After 2nd freeze cycle

5. Harvest Pump Time (Harvest Assist Duration) (S4 dip switch 6)

NOTICE

Factory set for proper operation. Do not adjust. Adjustment outside of the factory default setting may result in damage to the appliance.

Harvest pump time (harvest assist duration) is only active when S4 dip switch 7 is in the "ON" position. In the factory default position, the harvest pump time (harvest assist) starts with 50 sec. left to go in harvest cycle (S4 dip switch 6) and after the thermistor reaches 48°F (9°C) at the evaporator outlet and the control board reads 3.9 kΩ from the thermistor. The harvest pump time (harvest assist duration) is factory set, and no adjustment is required.

S4 Dip Switch Setting	Harvest Pump Time (Harvest Assist)	
	S5-4 OFF	S5-4 ON
No. 6		
OFF	50 sec.	25 sec.
ON	25 sec.	15 sec.

6. Harvest Pump Time (Harvest Assist) (S4 dip switch 7)

NOTICE

Factory set for proper operation. Do not adjust. Adjustment outside of the factory default setting may result in damage to the appliance.

a) Harvest Pump Time (Harvest Assist)

Depending on S4 dip switch 7 setting, the pump motor either stays off or is energized during the last seconds of the harvest cycle. When the pump motor is energized (S4 dip switch 7 on), water circulates over the evaporator. The harvest water valve is open during harvest for a maximum of 6 minutes or the length of harvest minus the harvest pump time value (S4 dip switch 6), whichever is shorter.

When S4 dip switch 7 is in the on position and harvest begins, X11 and X10 relays energize. A latching circuit is created through the X11 and X10 relays. For further details, see "VIII.B. Wiring Diagram." In the factory default position, 50 sec. before harvest termination, LED 4 turns off, inlet water valve and X11 relay de-energize. X10 relay remains energized through the latching circuit. Next, LED 3 turns on and control board K1 connector pin #5 (DBU wire) energizes, energizing the pump motor for the last seconds of harvest. Harvest pump time adjusted by S4 dip switch 1 & 2 and S5 dip switch 4 settings. Contact Technical Support before adjusting these settings.

b) Freeze-Time Correction

When S4 dip switch 7 is in the on position, freeze-time correction enabled.
See "II.C. Freeze-Time Correction Cycle (90 min.)."

S4 Dip Switch Setting No. 7	Harvest Pump Time (Harvest Assist)	Freeze-Time Correction (CB: 2A7664-02)
OFF		Disabled
ON		Enabled

7. Factory Use (S4 dip switch 8)

Factory set for proper operation. Do not adjust. This must be left in the factory default position.

8. Freeze Timer (S4 dip switch 9 & 10)

NOTICE

Adjust to proper specification, or the icemaker may not operate correctly.

The freeze timer setting determines the maximum allowed freeze time to prevent possible freeze-up issues. Upon termination of the freeze timer, the control board initiates the harvest cycle or pump-out cycle. After 2 consecutive freeze timer terminations, the control board shuts down the icemaker. In this case, see "II.1.2. Low Ice Production" for possible solutions. The freeze timer is factory set and no adjustment is required. Before changing this setting, contact Hoshizaki Technical Support at 1-800-233-1940 for recommendations.

S4 Dip Switch Setting		Time (min.)
No. 9	No. 10	
OFF	OFF	60
OFF	ON	50
ON	OFF	70
ON	ON	75

9. Float Switch Selector (S5 dip switch 1)

NOTICE

Do not adjust. This must be left in the factory default position or the icemaker will not operate correctly.

This dip switch setting allows use of this control board in single and dual float switch models. This model uses a single float switch style.

S5 Dip Switch Setting	Top or Bottom Float Switch Control
No. 1	
OFF	Bottom Float Switch Enabled
ON	Top Float Switch Enabled

10. Refill Counter (S5 dip switch 2 and 3)

NOTICE

Do not adjust. These must be left in the factory default position or the icemaker will not operate correctly.

S5 Dip Switch Setting		Refill Counter
No. 2	No. 3	
OFF	OFF	0
OFF	ON	1 refill
ON	OFF	9 refills
ON	ON	10 refills

11. Minimum Harvest Time (S5 dip switch 4)

NOTICE

Factory set for proper operation. Do not adjust. Adjustment outside the factory default setting may result in damage to the appliance.

S5 Dip Switch Setting	Minimum Harvest Timer
No. 4	
OFF	120 sec.
ON	70 sec.

12. Slush Control (S5 dip switch 5)

NOTICE

Factory set for proper operation. Do not adjust. Adjustment outside the factory default setting may result in damage to the appliance.

This dip switch setting provides slush control during the freeze cycle. When the evaporator temperature reaches 36°F (2.2°C) the control board reads a 5.8 kΩ signal from the thermistor and de-energizes the water pump for 10 sec. to melt ice slush and prevent ice slush from blocking the water supply tubing, causing irregular freeze patterns.

S5 Dip Switch Setting	Slush Control
No. 5	
OFF	Disabled
ON	Enabled

IV. Refrigeration Circuit and Component Service Information

⚠ WARNING

- This appliance should be diagnosed and repaired only by qualified service personnel to reduce the risk of death, electric shock, serious injury, or fire.
- Move the control switch to the "OFF" position and turn off the power supply. Place the disconnect in the "OFF" position. Lockout/Tagout to prevent the power supply from being turned back on inadvertently.
- **CHOKING HAZARD:** Ensure all components, fasteners, and thumbscrews are securely in place after the icemaker is serviced. Make sure that none have fallen into the dispenser unit/ice storage bin.
- Make sure all food zones in the icemaker and dispenser unit/ice storage bin are clean after service.

A. Refrigeration Circuit Service Information

⚠ WARNING

- Repairs requiring the refrigeration circuit to be opened must be performed by properly trained and EPA-certified service personnel.
- Use an electronic leak detector or soap bubbles to check for leaks. Add a trace of refrigerant to the system (if using an electronic leak detector), and then raise the pressure using nitrogen gas (140 PSIG). Do not use R-404A as a mixture with pressurized air for leak testing.

NOTICE

- Always recover the refrigerant and store it in an approved container. Do not discharge the refrigerant into the atmosphere.
- Do not leave the system open for longer than 15 min. when replacing or servicing parts. The Polyol Ester (POE) oils used in R-404A applications can absorb moisture quickly. Therefore it is important to prevent moisture from entering the system when replacing or servicing parts.
- Always install a new drier every time the sealed refrigeration system is opened. Do not replace the drier until after all other repair or replacement has been made. Install the new drier with the arrow on the drier in the direction of the refrigerant flow.
- When brazing, protect the drier by using a wet cloth to prevent the drier from overheating. Do not allow the drier to exceed 250°F (121°C).

1. Refrigerant Recovery

The icemaker is provided with refrigerant access valves. Using proper refrigerant practices, recover the refrigerant. Store the refrigerant in an approved container. Do not discharge the refrigerant into the atmosphere.

2. Brazing

⚠ WARNING

- R-404A itself is not flammable at atmospheric pressure and temperatures up to 176°F (80°C).
- R-404A itself is not explosive or poisonous. However, when exposed to high temperatures (open flames), R-404A can be decomposed to form hydrofluoric acid and carbonyl fluoride both of which are hazardous.
- Do not use silver alloy or copper alloy containing arsenic.

- 1) Braze all fittings while purging with nitrogen gas flowing at a pressure of 3 to 4 PSIG.
Note: Because the pipes in the evaporator case are specially coated to resist corrosion, it is important to make connections outside the evaporator case when possible. If it is necessary to braze inside the evaporator case, use sandpaper to remove the coating from the brazing connections before debrazing the components.

NOTICE

- Always install a new drier every time the sealed refrigeration system is opened.
- Do not replace the drier until after all other repair or replacement has been made. Install the new drier with the arrow on the drier in the direction of the refrigerant flow.
- When brazing, protect the drier by using a wet cloth to prevent the drier from overheating. Do not allow the drier to exceed 250°F (121°C).

- 2) Use an electronic leak detector or soap bubbles to check for leaks. Add a trace of refrigerant to the system (if using an electronic leak detector), and then raise the pressure using nitrogen gas (140 PSIG). Do not use R-404A as a mixture with pressurized air for leak testing.

3. Evacuation and Recharge (R-404A)

- 1) Attach a vacuum pump to the system. Be sure to connect the charging hoses to both high and low-side refrigerant access valves.

IMPORTANT

The vacuum level and vacuum pump may be the same as those for current refrigerants. However, the rubber hose and gauge manifold to be used for evacuation and refrigerant charge should be exclusively for POE oils.

- 2) Turn on the vacuum pump. Open the gauge manifold valves. Never allow the oil in the vacuum pump to flow backwards.
- 3) Allow the vacuum pump to pull down to a 29.9" Hg vacuum. Evacuating period depends on pump capacity.
- 4) Close the low-side valve and high-side valve on the gauge manifold.

- 5) Disconnect the gauge manifold hose from the vacuum pump and attach it to a refrigerant service cylinder. Remember to loosen the connection and purge the air from the hose. For the required refrigerant charge, see the rating label inside the icemaker. Hoshizaki recommends only virgin refrigerant or reclaimed refrigerant which meets AHRI Standard 700 (latest edition) be used.
- 6) A liquid charge is required when charging an R-404A system (to prevent fractionation). Place the service cylinder on the scales; if the service cylinder is not equipped with a dip tube, invert the service cylinder, then place it on the scales. Open the high-side valve on the gauge manifold.
- 7) Allow the system to charge with liquid until the proper charge weight is met.
- 8) If necessary, add any remaining charge to the system through the low-side.
NOTICE! To prevent compressor damage, use a throttling valve or liquid dispensing device to add the remaining liquid charge through the low-side refrigerant access valve with the icemaker running.
- 9) Close the high and low-side gauge manifold valves, then disconnect the gauge manifold hoses.
- 10) Cap the refrigerant access valves to prevent a possible leak.

B. Component Service Information

NOTICE

When replacing a component listed below, see the notes to help ensure proper operation.

Component	Notes
Compressor	1 phase: Install a new start capacitor, run capacitor, and start relay. 3 phase: Install a new magnetic contactor.
Thermostatic Expansion Valves	<ul style="list-style-type: none"> • Attach the thermostatic expansion valve bulb to the suction line in the same location as the previous bulb. • The bulb should be between the 10 and 2 o'clock positions on the tube. • Secure the bulb with the clamp and holder, then insulate it.
Hot Gas Valves Liquid Line Valves	<ul style="list-style-type: none"> • Replace the strainer if applicable. • Use copper tube of the same diameter and length when replacing valve lines.
Fan Motors	Install a new capacitor.
Pump Motor	Install a new capacitor.
Thermistor	<ul style="list-style-type: none"> • Attach the new thermistor to the suction line in the same location as the previous thermistor. • The thermistor should be at the 12 o'clock position on the tube. • Smoothly fill the recessed area of the thermistor holder with high thermal conductive type sealant. Hoshizaki America part number 4A0683-01 (Silicone Heat Sink Compound 10-8108 manufactured by GC Electronics), KE-4560 RTV (manufactured by ShinEtsu Silicones), or equivalent are recommended. • Secure the thermistor with the holder, then insulate it. • Be very careful to prevent damage to the leads.

C. Water Regulating Valve Adjustment (water-cooled model)

The water regulating valve is factory set, and generally no adjustment is required. However, when necessary, adjust the water regulator using the following procedure.

- 1) Prepare a thermometer to check the condenser drain temperature. Attach a pressure gauge to the high-side line of the system.
- 2) 5 min. after a freeze cycle starts, confirm that the thermometer reads 104°F to 115°F (40°C to 46°C). If it does not, rotate the adjustment screw by using a flat blade screwdriver until the temperature is in the proper range. See Fig. 3. Next, check that the reference pressure is in the range indicated in the Head Pressure table in the Performance Data section. If it is not in the proper range, verify the refrigerant charge.
- 3) Check that the condenser drain temperature is stable.

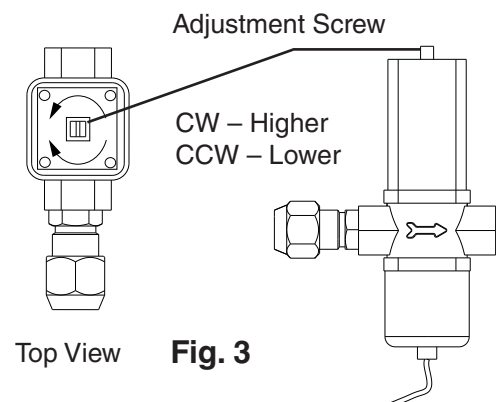

V. Maintenance

The maintenance schedule below is a guideline. More frequent maintenance may be required depending on water quality, the appliance's environment, and local sanitation regulations.

WARNING

- Only qualified service technicians should service the appliance.
- To reduce the risk of electric shock, do not touch the control switch or service switch with damp hands
- Before servicing: Move the control switch to the "OFF" position and turn off the power supply. Place the disconnect in the "OFF" position. Lockout/Tagout to prevent the power supply from being turned back on inadvertently.
- **CHOKING HAZARD:** Ensure all components, fasteners, and thumbscrews are securely in place after any maintenance is done to the icemaker. Make sure that none have fallen into the dispenser unit/ice storage bin.

Maintenance Schedule

Frequency	Area	Task
Daily	Scoop	Clean the ice scoop using a neutral cleaner. Rinse thoroughly after cleaning.
Bi-Weekly	Air Filters	Inspect. Wash with warm water and neutral cleaner if dirty.
Monthly	External Water Filters	Check for proper pressure and change if necessary.
	Icemaker Exterior	Wipe down with a clean, soft cloth. Use a damp cloth containing a neutral cleaner to wipe off oil or dirt build up. Clean any chlorine staining (rust colored spots) using a non-abrasive cleanser.
	Underside of Icemaker and Top Kits; Bin Door and Snout	Wipe down with a clean cloth and warm water.
Yearly	Icemaker and Dispenser Unit/Ice Storage Bin Liner	Clean and sanitize per the cleaning and sanitizing instructions provided in the instruction manual or maintenance label on the icemaker.
	Water Supply Inlet	Close the icemaker water supply line shut-off valve and drain the water system. Clean the water supply inlet screen.
	Condenser	Inspect. Clean if necessary by using a brush or vacuum cleaner. More frequent cleaning may be required depending on location.
	Water Hoses	Inspect the water hoses and clean/replace if necessary.

VI. Preparing the Appliance for Periods of Non-Use

NOTICE
<ul style="list-style-type: none">• When storing the appliance for an extended time or in sub-freezing temperatures, follow the instructions below to prevent damage.• The pump motor is energized continuously when the control switch is in the "SERVICE" position.

When the appliance is not used for two or three days under normal conditions, it is sufficient to move the control switch to the "OFF" position. When storing the appliance for an extended time or in sub-freezing temperatures, follow the instructions below.

1. Remove the water from the icemaker water line:

- 1) Turn off the power supply, then remove the front panel.
- 2) Move the control switch on the control box to the "OFF" position.
- 3) Close the icemaker water supply line shut-off valve, then open the icemaker water supply line drain valve.
- 4) Allow the line to drain by gravity.
- 5) Attach compressed air or carbon dioxide supply to the icemaker water supply line drain valve.
- 6) Make sure at least 3 min. have elapsed since you turned off the power supply. Move the control switch is in the "ICE" position.
- 7) Replace the front panel in its correct position, then turn on the power supply.
- 8) Blow the icemaker water supply line out using compressed air or carbon dioxide.
- 9) Close the icemaker water supply line drain valve.

2. Drain the water tank:

- 1) Turn off the power supply, then remove the front panel.
- 2) Move the service switch to the "DRAIN" position, then move the control switch to the "SERVICE" position.
- 3) Replace the front panel in its correct position, then turn on the power supply for 2 minutes.
- 4) After 2 min., turn off the power supply, then remove the front panel.
- 5) Move the control switch to the "OFF" position.
- 6) Replace the front panel in its correct position.
- 7) Remove all ice from the dispenser unit/ice storage bin. Clean the dispenser unit/ice storage bin using a neutral cleaner. Rinse thoroughly after cleaning.
- 8) Close the icemaker water supply line drain valve.

3. On water-cooled model, remove the water from the water-cooled condenser:

- 1) Make sure the power supply is off, then remove the front panel and right side panel.
- 2) Close the condenser water supply line shut-off valve. If connected to a closed loop system, also close the condenser return line shut-off valve.
- 3) Open the condenser water supply line drain valve. If connected to a closed loop system, also open the condenser return line drain valve.
- 4) Attach a compressed air or carbon dioxide supply to the condenser water supply line drain valve.
- 5) Open the water regulating valve by using a screwdriver to pry up on the spring retainer underneath the spring. While holding the valve open, blow out the condenser using the compressed air or carbon dioxide supply until water stops coming out.
- 6) Close the drain valve(s).
- 7) Replace the right side panel and front panel in their correct positions.

VII. Disposal

The appliance contains refrigerant and must be disposed of in accordance with applicable national, state, and local codes and regulations. Refrigerant must be recovered by properly certified service personnel.

VIII. Technical Information

We reserve the right to make changes in specifications and design without prior notice.

A. Specification and Performance Data Sheets

Pressure data is recorded at 5 min. into freezing cycle. The data not in bold should be used for reference only.

1. KML-325MAJ

Specification Sheet

AC SUPPLY VOLTAGE	115/60/1	
AMPERAGE	8.4 A (5 Min. Freeze AT 104°F / WT 80°F)	
MINIMUM CIRCUIT AMPACITY	15 A	
MAXIMUM FUSE SIZE	15 A	
ELECTRIC & WATER CONSUMPTION	90/70°F	70/50°F
ELECTRIC W (kWH/100 lbs.)	720 (5.72)	710 (4.51)
WATER gal./24HR (gal./100 lbs.)	60 (19.9)	161 (42.3)
ICE PRODUCTION PER CYCLE	8.1 lbs. (3.7 kg) (360 pcs.)	
BIN CONTROL SYSTEM	Thermostat	
REFRIGERANT CHARGE	R404A, 1 lb. 5.2 oz. (600g)	

Performance Data Sheet

APPROXIMATE ICE PRODUCTION PER 24 HR.	AMBIENT TEMP. (°F/°C)	WATER TEMP. (°F/°C)					
		50/10		70/21		90/32	
	70/21	380	<u>172</u>	357	<u>162</u>	331	<u>150</u>
	80/27	362	<u>164</u>	326	<u>148</u>	304	<u>138</u>
	90/32	357	<u>162</u>	300	<u>136</u>	277	<u>125</u>
lbs./day kg./day	100/38	354	<u>161</u>	295	<u>134</u>	255	<u>116</u>
APPROXIMATE ELECTRIC CONSUMPTION	70/21	710		713		722	
	80/27	712		717		728	
	90/32	713		720		730	
watts	100/38	716		722		740	
APPROXIMATE WATER CONSUMPTION PER 24 HR.	70/21	161	<u>0.61</u>	131	<u>0.50</u>	114	<u>0.43</u>
	80/27	138	<u>0.52</u>	92	<u>0.35</u>	88	<u>0.33</u>
	90/32	131	<u>0.50</u>	60	<u>0.23</u>	50	<u>0.19</u>
gal./day m ³ /day	100/38	97	<u>0.37</u>	57	<u>0.22</u>	41	<u>0.15</u>
FREEZING CYCLE TIME	70/21	26		29		32	
	80/27	28		31		35	
	90/32	29		33		37	
min.	100/38	29		34		40	
HARVEST CYCLE TIME	70/21	4.0		3.4		3.2	
	80/27	3.6		2.7		2.8	
	90/32	3.4		2.1		2.1	
min.	100/38	2.8		2.1		2.1	
HEAD PRESSURE	70/21	213	<u>15.0</u>	229	<u>16.1</u>	266	<u>18.7</u>
	80/27	225	<u>15.8</u>	250	<u>17.6</u>	296	<u>20.8</u>
	90/32	229	<u>16.1</u>	267	<u>18.8</u>	310	<u>21.8</u>
PSIG kg/cm ² G	100/38	242	<u>17.0</u>	277	<u>19.5</u>	350	<u>24.6</u>
SUCTION PRESSURE	70/21	55	<u>3.9</u>	56	<u>3.9</u>	58	<u>4.1</u>
	80/27	56	<u>3.9</u>	57	<u>4.0</u>	59	<u>4.2</u>
	90/32	56	<u>3.9</u>	58	<u>4.1</u>	60	<u>4.2</u>
PSIG kg/cm ² G	100/38	56	<u>4.0</u>	58	<u>4.1</u>	62	<u>4.4</u>
TOTAL HEAT OF REJECTION FROM CONDENSER	5,800 BTU/h [AT 90°F (32°C) / WT 70°F (21°C)]						
TOTAL HEAT OF REJECTION FROM COMPRESSOR	900 BTU/h [AT 90°F (32°C) / WT 70°F (21°C)]						

2. KML-325MWJ

Specification Sheet

AC SUPPLY VOLTAGE	115/60/1	
AMPERAGE	8.4 A (5 Min. Freeze AT 104°F / WT 80°F)	
MINIMUM CIRCUIT AMPACITY	15 A	
MAXIMUM FUSE SIZE	15 A	
ELECTRIC & WATER CONSUMPTION	90/70°F	70/50°F
ELECTRIC W (KWH/100 lbs.)	670 (4.51)	690 (4.31)
WATER gal./24HR (gal./100 lbs.)	60 (17.0)	122 (31.6)
WATER COOLED CONDENSER gal./24HR (gal./100 lbs.)	376 (106)	155 (40)
ICE PRODUCTION PER CYCLE	7.9 lbs. (3.6 kg) 360pcs.	
BIN CONTROL SYSTEM	Thermostat	
REFRIGERANT CHARGE	R404A, 1 lb. 1.6 oz. (500g)	

Performance Data Sheet

APPROXIMATE ICE PRODUCTION PER 24 HR.	AMBIENT TEMP. (°F/°C)	WATER TEMP. (°F/°C)					
		50/10		70/21		90/32	
	70/21	385	<u>175</u>	376	<u>171</u>	362	<u>164</u>
	80/27	378	<u>172</u>	365	<u>165</u>	349	<u>158</u>
	90/32	376	<u>171</u>	355	<u>161</u>	339	<u>154</u>
lbs./day kg./day	100/38	372	<u>169</u>	351	<u>159</u>	325	<u>147</u>
APPROXIMATE ELECTRIC CONSUMPTION	70/21	690		684		674	
	80/27	686		676		666	
	90/32	684		670		660	
watts	100/38	682		668		650	
APPROXIMATE WATER CONSUMPTION PER 24 HR.	70/21	277	<u>1.05</u>	324	<u>1.23</u>	406	<u>1.54</u>
	80/27	313	<u>1.18</u>	385	<u>1.46</u>	478	<u>1.81</u>
	90/32	324	<u>1.23</u>	437	<u>1.65</u>	527	<u>1.99</u>
gal./day m ³ /day	100/38	402	<u>1.52</u>	458	<u>1.73</u>	610	<u>2.31</u>
FREEZING CYCLE TIME	70/21	26		27		25	
	80/27	27		28		25	
	90/32	27		29		26	
min.	100/38	26		28		24	
HARVEST CYCLE TIME	70/21	3.3		2.9		2.8	
	80/27	3.0		2.5		2.5	
	90/32	2.9		2.1		2.1	
min.	100/38	2.5		2.1		2.0	
HEAD PRESSURE	70/21	267	<u>18.8</u>	268	<u>18.8</u>	272	<u>19.2</u>
	80/27	267	<u>18.8</u>	268	<u>18.9</u>	275	<u>19.4</u>
	90/32	268	<u>18.8</u>	269	<u>18.9</u>	275	<u>19.4</u>
PSIG kg/cm ² G	100/38	270	<u>19.0</u>	270	<u>19.0</u>	281	<u>19.8</u>
SUCTION PRESSURE	70/21	56	<u>3.9</u>	56	<u>3.9</u>	56	<u>4.0</u>
	80/27	56	<u>3.9</u>	55	<u>3.9</u>	57	<u>4.0</u>
	90/32	56	<u>3.9</u>	55	<u>3.9</u>	56	<u>3.9</u>
PSIG kg/cm ² G	100/38	56	<u>4.0</u>	55	<u>3.9</u>	57	<u>4.0</u>
TOTAL HEAT OF REJECTION FROM CONDENSER	5,500 BTU/h [AT 90°F (32°C) / WT 70°F (21°C)]						
TOTAL HEAT OF REJECTION FROM COMPRESSOR	900 BTU/h [AT 90°F (32°C) / WT 70°F (21°C)]						
WATER FLOW FOR CONDENSER	23 gal./h [AT 100°F (38°C) / WT 90°F (32°C)]						
PRESSURE DROP OF COOLING WATER LINE	less than 10 PSIG						

3. KML-500MAJ

Specification Sheet

AC SUPPLY VOLTAGE	115/60/1	
AMPERAGE	7.6 A (5 Min. Freeze AT 104°F / WT 80°F)	
MINIMUM CIRCUIT AMPACITY	20 A	
MAXIMUM FUSE SIZE	20 A	
ELECTRIC & WATER CONSUMPTION	90/70°F	70/50°F
ELECTRIC W (KWH/100 lbs.)	930 (5.55)	850 (4.64)
WATER gal./24HR (gal./100 lbs.)	64 (16.0)	143 (32.4)
ICE PRODUCTION PER CYCLE	7.9 lbs. (3.6 kg) 360pcs.	
BIN CONTROL SYSTEM	Thermostat	
REFRIGERANT CHARGE	R404A, 1 lb. 10.5 oz. (750g)	

Performance Data Sheet

APPROXIMATE ICE PRODUCTION PER 24 HR.	AMBIENT TEMP. (°F/°C)	WATER TEMP. (°F/°C)					
		50/10		70/21		90/32	
	70/21	442	<u>200</u>	430	<u>195</u>	399	<u>181</u>
	80/27	433	<u>196</u>	413	<u>188</u>	376	<u>170</u>
	90/32	430	<u>195</u>	400	<u>181</u>	365	<u>165</u>
lbs./day kg./day	100/38	419	<u>190</u>	392	<u>178</u>	332	<u>151</u>
APPROXIMATE ELECTRIC CONSUMPTION	70/21	850		873		881	
	80/27	868		904		898	
	90/32	873		930		930	
watts	100/38	867		930		930	
APPROXIMATE WATER CONSUMPTION PER 24 HR.	70/21	143	<u>0.54</u>	120	<u>0.45</u>	107	<u>0.40</u>
	80/27	126	<u>0.48</u>	89	<u>0.34</u>	87	<u>0.33</u>
	90/32	120	<u>0.45</u>	64	<u>0.24</u>	57	<u>0.21</u>
gal./day m ³ /day	100/38	93	<u>0.35</u>	62	<u>0.24</u>	50	<u>0.19</u>
FREEZING CYCLE TIME	70/21	23		24		25	
	80/27	23		25		27	
	90/32	24		26		28	
min.	100/38	24		27		30	
HARVEST CYCLE TIME	70/21	3.5		3.1		2.9	
	80/27	3.2		2.5		2.6	
	90/32	3.1		2.0		2.0	
min.	100/38	2.6		2.0		2.1	
HEAD PRESSURE	70/21	250	<u>17.6</u>	268	<u>18.9</u>	289	<u>20.3</u>
	80/27	264	<u>18.6</u>	293	<u>20.6</u>	310	<u>21.8</u>
	90/32	268	<u>18.9</u>	313	<u>22.0</u>	332	<u>23.4</u>
PSIG kg/cm ² G	100/38	271	<u>19.0</u>	318	<u>22.3</u>	350	<u>24.6</u>
SUCTION PRESSURE	70/21	57	<u>4.0</u>	58	<u>4.0</u>	59	<u>4.1</u>
	80/27	57	<u>4.0</u>	58	<u>4.1</u>	60	<u>4.2</u>
	90/32	58	<u>4.0</u>	59	<u>4.1</u>	61	<u>4.3</u>
PSIG kg/cm ² G	100/38	58	<u>4.1</u>	59	<u>4.2</u>	62	<u>4.4</u>
TOTAL HEAT OF REJECTION FROM CONDENSER	6,200 BTU/h [AT 90°F (32°C) / WT 70°F (21°C)]						
TOTAL HEAT OF REJECTION FROM COMPRESSOR	1,200 BTU/h [AT 90°F (32°C) / WT 70°F (21°C)]						

4. KML-500MWJ

Specification Sheet

AC SUPPLY VOLTAGE	115/60/1	
AMPERAGE	9.6 A (5 Min. Freeze AT 104°F / WT 80°F)	
MINIMUM CIRCUIT AMPACITY	20 A	
MAXIMUM FUSE SIZE	20 A	
ELECTRIC & WATER CONSUMPTION	90/70°F	70/50°F
ELECTRIC W (kWH/100 lbs.)	930 (4.33)	890 (3.93)
WATER gal./24HR (gal./100 lbs.)	82 (16.0)	125 (22.9)
WATER COOLED CONDENSER gal./24HR (gal./100 lbs.)	567 (110)	279 (51)
ICE PRODUCTION PER CYCLE	7.9 lbs. (3.6 kg) 360pcs.	
BIN CONTROL SYSTEM	Thermostat	
REFRIGERANT CHARGE	R404A, 0 lb. 15.9 oz. (450g)	

Performance Data Sheet

APPROXIMATE ICE PRODUCTION PER 24 HR.	AMBIENT TEMP. (°F/°C)	WATER TEMP. (°F/°C)					
		50/10		70/21		90/32	
	70/21	543	<u>246</u>	535	<u>243</u>	515	<u>233</u>
	80/27	537	<u>243</u>	524	<u>238</u>	499	<u>226</u>
	90/32	535	<u>243</u>	515	<u>234</u>	492	<u>223</u>
lbs./day kg./day	100/38	528	<u>239</u>	510	<u>231</u>	470	<u>213</u>
APPROXIMATE ELECTRIC CONSUMPTION	70/21	890		902		909	
	80/27	899		917		920	
	90/32	902		930		935	
watts	100/38	900		931		940	
APPROXIMATE WATER CONSUMPTION PER 24 HR.	70/21	403	<u>1.53</u>	475	<u>1.80</u>	584	<u>2.21</u>
	80/27	458	<u>1.73</u>	570	<u>2.16</u>	684	<u>2.59</u>
	90/32	475	<u>1.80</u>	649	<u>2.46</u>	763	<u>2.89</u>
gal./day m ³ /day	100/38	588	<u>2.23</u>	676	<u>2.56</u>	868	<u>3.29</u>
FREEZING CYCLE TIME	70/21	18		19		20	
	80/27	19		20		21	
	90/32	19		20		21	
min.	100/38	19		21		23	
HARVEST CYCLE TIME	70/21	2.6		2.5		2.4	
	80/27	2.5		2.2		2.3	
	90/32	2.5		2.1		2.0	
min.	100/38	2.3		2.0		2.0	
HEAD PRESSURE	70/21	275	<u>19.3</u>	276	<u>19.4</u>	277	<u>19.5</u>
	80/27	276	<u>19.4</u>	278	<u>19.6</u>	279	<u>19.6</u>
	90/32	276	<u>19.4</u>	280	<u>19.7</u>	281	<u>19.7</u>
PSIG kg/cm ² G	100/38	276	<u>19.4</u>	280	<u>19.7</u>	281	<u>19.8</u>
SUCTION PRESSURE	70/21	57	<u>4.0</u>	57	<u>4.0</u>	57	<u>4.0</u>
	80/27	57	<u>4.0</u>	57	<u>4.0</u>	57	<u>4.0</u>
	90/32	57	<u>4.0</u>	57	<u>4.0</u>	57	<u>4.0</u>
PSIG kg/cm ² G	100/38	57	<u>4.0</u>	57	<u>4.0</u>	57	<u>4.0</u>
TOTAL HEAT OF REJECTION FROM CONDENSER	8,000 BTU/h [AT 90°F (32°C) / WT 70°F (21°C)]						
TOTAL HEAT OF REJECTION FROM COMPRESSOR	1,400 BTU/h [AT 90°F (32°C) / WT 70°F (21°C)]						
WATER FLOW FOR CONDENSER	33 gal./h [AT 100°F (38°C) / WT 90°F (32°C)]						
PRESSURE DROP OF COOLING WATER LINE	less than 10 PSIG						

5. KML-700MAJ

Specification Sheet

AC SUPPLY VOLTAGE	115/60/1	
AMPERAGE	14.2 A (5 Min. Freeze AT 104°F / WT 80°F)	
MINIMUM CIRCUIT AMPACITY	20 A	
MAXIMUM FUSE SIZE	20 A	
ELECTRIC & WATER CONSUMPTION	90/70°F	70/50°F
ELECTRIC W (kWH/100 lbs.)	1230 (5.16)	1120 (4.10)
WATER gal./24HR (gal./100 lbs.)	92 (16.0)	223 (33.9)
ICE PRODUCTION PER CYCLE	10.4 lbs. (4.7 kg) 480pcs.	
BIN CONTROL SYSTEM	Thermostat	
REFRIGERANT CHARGE	R404A, 2 lb. 10.3 oz. (1200g)	

Performance Data Sheet

APPROXIMATE ICE PRODUCTION PER 24 HR.	AMBIENT TEMP. (°F/°C)	WATER TEMP. (°F/°C)					
		50/10		70/21		90/32	
	70/21	658	<u>298</u>	633	<u>287</u>	588	<u>267</u>
	80/27	639	<u>290</u>	600	<u>272</u>	549	<u>249</u>
	90/32	633	<u>287</u>	572	<u>259</u>	522	<u>237</u>
lbs./day <u>kg./day</u>	100/38	620	<u>281</u>	560	<u>254</u>	477	<u>216</u>
APPROXIMATE ELECTRIC CONSUMPTION	70/21	1120		1152		1202	
	80/27	1145		1195		1247	
	90/32	1152		1230		1282	
watts	100/38	1164		1242		1330	
APPROXIMATE WATER CONSUMPTION PER 24 HR.	70/21	223	<u>0.84</u>	185	<u>0.70</u>	166	<u>0.63</u>
	80/27	194	<u>0.73</u>	134	<u>0.51</u>	134	<u>0.51</u>
	90/32	185	<u>0.70</u>	92	<u>0.35</u>	84	<u>0.32</u>
gal./day <u>m³/day</u>	100/38	141	<u>0.53</u>	90	<u>0.34</u>	76	<u>0.29</u>
FREEZING CYCLE TIME	70/21	20		21		24	
	80/27	21		23		26	
	90/32	21		25		27	
min.	100/38	22		25		29	
HARVEST CYCLE TIME	70/21	3.6		3.1		3.0	
	80/27	3.2		2.5		2.7	
	90/32	3.1		2.1		2.1	
min.	100/38	2.7		2.1		2.1	
HEAD PRESSURE	70/21	258	<u>18.1</u>	275	<u>19.3</u>	303	<u>21.3</u>
	80/27	271	<u>19.1</u>	297	<u>20.9</u>	328	<u>23.1</u>
	90/32	275	<u>19.3</u>	316	<u>22.2</u>	346	<u>24.3</u>
PSIG <u>kg/cm²G</u>	100/38	282	<u>19.8</u>	323	<u>22.7</u>	374	<u>26.3</u>
SUCTION PRESSURE	70/21	54	<u>3.8</u>	56	<u>3.9</u>	57	<u>4.0</u>
	80/27	56	<u>3.9</u>	59	<u>4.1</u>	58	<u>4.1</u>
	90/32	56	<u>3.9</u>	61	<u>4.3</u>	61	<u>4.3</u>
PSIG <u>kg/cm²G</u>	100/38	55	<u>3.9</u>	61	<u>4.3</u>	61	<u>4.3</u>
TOTAL HEAT OF REJECTION FROM CONDENSER	11,300 BTU/h [AT 90°F (32°C) / WT 70°F (21°C)]						
TOTAL HEAT OF REJECTION FROM COMPRESSOR	1,500 BTU/h [AT 90°F (32°C) / WT 70°F (21°C)]						

6. KML-700MWJ

Specification Sheet

AC SUPPLY VOLTAGE	115/60/1
AMPERAGE	12.6 A (5 Min. Freeze AT 104°F / WT 80°F)
MINIMUM CIRCUIT AMPACITY	20 A
MAXIMUM FUSE SIZE	20 A
ELECTRIC & WATER CONSUMPTION	90/70°F 70/50°F
ELECTRIC W (kWH/100 lbs.)	1100 (3.61) 1070 (3.40)
WATER gal./24HR (gal./100 lbs.)	117 (16.0) 181 (24.0)
WATER COOLED CONDENSER gal./24HR (gal./100 lbs.)	810 (111) 454 (60)
ICE PRODUCTION PER CYCLE	10.7 lbs. (4.8 kg) 480pcs.
BIN CONTROL SYSTEM	Thermostat
REFRIGERANT CHARGE	R404A, 1 lb. 6 oz. (625g)

Performance Data Sheet

APPROXIMATE ICE PRODUCTION PER 24 HR.	AMBIENT TEMP. (°F/°C)	WATER TEMP. (°F/°C)					
		50/10		70/21		90/32	
	70/21	756	<u>343</u>	748	<u>339</u>	688	<u>312</u>
	80/27	750	<u>340</u>	738	<u>335</u>	651	<u>295</u>
	90/32	748	<u>339</u>	730	<u>331</u>	653	<u>296</u>
lbs./day kg./day	100/38	720	<u>326</u>	712	<u>323</u>	582	<u>264</u>
APPROXIMATE ELECTRIC CONSUMPTION	70/21	1070		1079		1089	
	80/27	1077		1090		1100	
	90/32	1079		1100		1110	
watts	100/38	1080		1102		1120	
APPROXIMATE WATER CONSUMPTION PER 24 HR.	70/21	635	<u>2.40</u>	721	<u>2.73</u>	1336	<u>5.06</u>
	80/27	700	<u>2.65</u>	833	<u>3.15</u>	1725	<u>6.53</u>
	90/32	721	<u>2.73</u>	927	<u>3.51</u>	1715	<u>6.49</u>
gal./day m ³ /day	100/38	1062	<u>4.02</u>	1112	<u>4.21</u>	2439	<u>9.23</u>
FREEZING CYCLE TIME	70/21	18		18		19	
	80/27	18		19		20	
	90/32	18		19		20	
min.	100/38	18		19		21	
HARVEST CYCLE TIME	70/21	2.9		2.7		2.6	
	80/27	2.7		2.3		2.4	
	90/32	2.7		2.1		2.1	
min.	100/38	2.4		2.1		2.1	
HEAD PRESSURE	70/21	237	<u>16.7</u>	238	<u>16.7</u>	240	<u>16.9</u>
	80/27	238	<u>16.7</u>	239	<u>16.8</u>	242	<u>17.0</u>
	90/32	238	<u>16.7</u>	240	<u>16.9</u>	243	<u>17.1</u>
PSIG kg/cm ² G	100/38	239	<u>16.8</u>	241	<u>16.9</u>	246	<u>17.3</u>
SUCTION PRESSURE	70/21	58	<u>4.1</u>	59	<u>4.1</u>	59	<u>4.2</u>
	80/27	58	<u>4.1</u>	59	<u>4.2</u>	60	<u>4.2</u>
	90/32	59	<u>4.1</u>	60	<u>4.2</u>	61	<u>4.3</u>
PSIG kg/cm ² G	100/38	59	<u>4.1</u>	60	<u>4.2</u>	61	<u>4.3</u>
TOTAL HEAT OF REJECTION FROM CONDENSER	12,600 BTU/h [AT 90°F (32°C) / WT 70°F (21°C)]						
TOTAL HEAT OF REJECTION FROM COMPRESSOR	1,500 BTU/h [AT 90°F (32°C) / WT 70°F (21°C)]						
WATER FLOW FOR CONDENSER	98 gal./h [AT 100°F (38°C) / WT 90°F (32°C)]						
PRESSURE DROP OF COOLING WATER LINE	less than 10 PSIG						

7. KML-700MRJ

Specification Sheet

AC SUPPLY VOLTAGE	115/60/1		
AMPERAGE	13.7 A (5 Min. Freeze AT 104°F/WT 80°F)		
MINIMUM CIRCUIT AMPACITY	20 A		
MAXIMUM FUSE SIZE	20 A		
ELECTRIC & WATER CONSUMPTION	90/70°F	70/50°F	
ELECTRIC W (kWH/100 lbs.)	1250 (4.90)	1130 (4.14)	
WATER gal./24HR (gal./100 lbs.)	101 (16.4)	223 (33.9)	
CONNECTIONS - ELECTRIC	Permanent - Connection		
- WATER SUPPLY	Inlet	1/2" FPT	3/8" min. I.D pipe
- DRAIN	Outlet	3/4" FPT	
BIN CONTROL SYSTEM	Thermostat		
ICE PRODUCTION PER CYCLE	9.4 lbs. (4.3 kg) 480pcs.		
BIN CONTROL SYSTEM	Thermostatic		
CONDENSER	Air-Cooled Remote, Condenser Unit URC-9F		
REFRIGERANT CHARGE	TOTAL R404A, 11 lb. 7.4 oz. (5200 g)		
	ICEMAKER, 7 lb. 8.6 oz. (3420 g)		
	CONDENSER, 3 lb. 14.8 oz. (1780 g)		

Performance Data Sheet

APPROXIMATE ICE PRODUCTION PER 24 HR.	AMBIENT TEMP. (°F/°C)	WATER TEMP. (°F/°C)					
		50/10		70/21		90/32	
	70/21	657	<u>298</u>	644	<u>292</u>	600	<u>272</u>
	80/27	647	<u>294</u>	628	<u>285</u>	569	<u>258</u>
	90/32	644	<u>292</u>	614	<u>278</u>	561	<u>254</u>
lbs./day <u>kg./day</u>	100/38	626	<u>284</u>	601	<u>273</u>	512	<u>232</u>
APPROXIMATE ELECTRIC CONSUMPTION	70/21	1130		1165		1200	
	80/27	1157		1211		1239	
	90/32	1165		1250		1281	
watts	100/38	1168		1257		1310	
APPROXIMATE WATER CONSUMPTION PER 24 HR.	70/21	223	<u>0.84</u>	187	<u>0.71</u>	169	<u>0.64</u>
	80/27	196	<u>0.74</u>	140	<u>0.53</u>	140	<u>0.53</u>
	90/32	187	<u>0.71</u>	101	<u>0.38</u>	93	<u>0.35</u>
gal./day <u>m³/day</u>	100/38	147	<u>0.55</u>	99	<u>0.37</u>	86	<u>0.32</u>
FREEZING CYCLE TIME	70/21	18		19		20	
	80/27	19		20		21	
	90/32	19		20		22	
min.	100/38	19		21		23	
HARVEST CYCLE TIME	70/21	3.3		3.0		2.8	
	80/27	3.0		2.4		2.5	
	90/32	3.0		2.0		2.0	
min.	100/38	2.5		2.0		2.0	
HEAD PRESSURE	70/21	200	<u>14.1</u>	216	<u>15.2</u>	237	<u>16.7</u>
	80/27	212	<u>14.9</u>	237	<u>16.7</u>	257	<u>18.1</u>
	90/32	216	<u>15.2</u>	255	<u>17.9</u>	276	<u>19.4</u>
PSIG <u>kg/cm²G</u>	100/38	220	<u>15.5</u>	260	<u>18.3</u>	295	<u>20.7</u>
SUCTION PRESSURE	70/21	42	<u>3.0</u>	43	<u>3.0</u>	47	<u>3.3</u>
	80/27	43	<u>3.0</u>	45	<u>3.1</u>	50	<u>3.5</u>
	90/32	43	<u>3.0</u>	46	<u>3.2</u>	51	<u>3.6</u>
PSIG <u>kg/cm²G</u>	100/38	45	<u>3.1</u>	47	<u>3.3</u>	55	<u>3.9</u>
TOTAL HEAT OF REJECTION FROM CONDENSER	9,400 BTU/h [AT 90°F (32°C) / WT 70°F (21°C)]						
TOTAL HEAT OF REJECTION FROM COMPRESSOR	1,400 BTU/h [AT 90°F (32°C) / WT 70°F (21°C)]						

B. Wiring Diagram

1. KML-325M_J, KML-500M_J, KML-700M_J

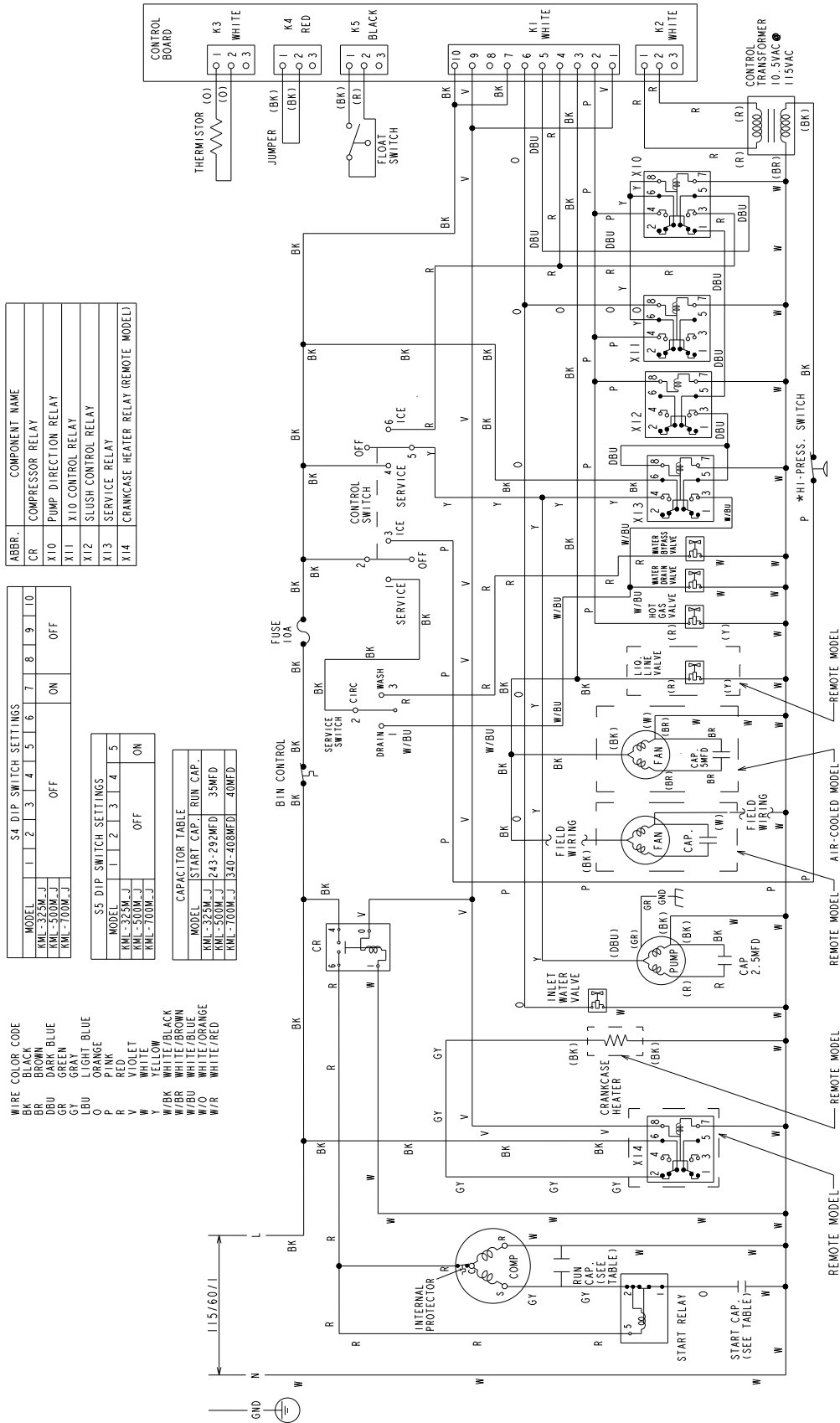

ABBR.	COMPONENT NAME
CR	COMPRESSOR RELAY
X10	PUMP DIRECTION RELAY
X11	X10 CONTROL RELAY
X12	SLUSH CONTROL RELAY
X13	SERVICE RELAY
X14	CRANKCASE HEATER RELAY (REMOTE MODEL)

S4 DIP SWITCH SETTINGS										
MODEL	1	2	3	4	5	6	7	8	9	10
KML-325M-J										
KML-500M-J										
KML-700M-J										

S5 DIP SWITCH SETTINGS					
MODEL	1	2	3	4	5
KML-325M-J					
KML-500M-J					
KML-700M-J					

CAPACITOR TABLE			
MODEL	START CAP.	RUN CAP.	
KML-325M-J	243-292MFD	35MFD	
KML-500M-J	340-408MFD	40MFD	

WIRE COLOR CODE	
BK	BLACK
BR	BROWN
DBU	DARK BLUE
GR	GREEN
GY	GRAY
LB	LIGHT BLUE
O	ORANGE
P	PINK
R	RED
V	VIOLET
Y	YELLOW
W/BK	WHITE/BLACK
W/BR	WHITE/BROWN
W/DBU	WHITE/DARK BLUE
W/GR	WHITE/GREEN
W/O	WHITE/ORANGE
W/R	WHITE/RED

* High-Pressure Switch		
Air-Cooled Model	Water-Cooled Model	
Cut-out	412±2 ^{±0} PSIG	384±2 ^{±0} PSIG
Cut-in	327±22 PSIG	284±22 PSIG