



UnderCounter Ice Machines

U65 Models

Installation, Operation and Maintenance Manual



Original Document

 **Caution**

Read this instruction before operating this equipment.

Safety Notices

Safety Notices

Read these precautions to prevent personal injury:

- Read this manual thoroughly before operating, installing or performing maintenance on the equipment. Failure to follow instructions in this manual can cause property damage, injury or death.
- Routine adjustments and maintenance procedures outlined in this manual are not covered by the warranty.
- Proper installation, care and maintenance are essential for maximum performance and trouble-free operation of your equipment. Visit our website www.manitowocice.com for manual updates, translations, or contact information for service agents in your area.
- This equipment contains high voltage electricity and refrigerant charge. Installation and repairs are to be performed by properly trained technicians aware of the dangers of dealing with high voltage electricity and refrigerant under pressure. The technician must also be certified in proper refrigerant handling and servicing procedures. All lockout and tag out procedures must be followed when working on this equipment.
- This equipment is intended for indoor use only. Do not install or operate this equipment in outdoor areas.

DEFINITIONS

DANGER

Indicates a hazardous situation that, if not avoided, will result in death or serious injury. This applies to the most extreme situations.

Warning

Indicates a hazardous situation that, if not avoided, could result in death or serious injury.

Caution

Indicates a hazardous situation that, if not avoided, could result in minor or moderate injury.

Notice

Indicates information considered important, but not hazard-related (e.g. messages relating to property damage).

NOTE: Indicates useful, extra information about the procedure you are performing.

Warning

Follow these precautions to prevent personal injury during installation of this equipment:

- Installation must comply with all applicable equipment fire and health codes with the authority having jurisdiction.
- To avoid instability the installation area must be capable of supporting the combined weight of the equipment and product. Additionally the equipment must be level side to side and front to back.
- Remove all removable panels before lifting and installing and use appropriate safety equipment during installation and servicing. Two or more people are required to lift or move this appliance to prevent tipping and/or injury.
- Connect to a potable water supply only.
- Do not damage the refrigeration circuit when installing, maintaining or servicing the unit.

Warning

Follow these electrical requirements during installation of this equipment:

- All field wiring must conform to all applicable codes of the authority having jurisdiction. It is the responsibility of the end user to provide the disconnect means to satisfy local codes. Refer to rating plate for proper voltage.
- This appliance must be grounded.
- This equipment must be positioned so that the plug is accessible unless other means for disconnection from the power supply (e.g., circuit breaker or disconnect switch) is provided.
- Check all wiring connections, including factory terminals, before operation. Connections can become loose during shipment and installation.

⚠ DANGER

Do not operate equipment that has been misused, abused, neglected, damaged, or altered/modified from that of original manufactured specifications. This appliance is not intended for use by persons (including children) with reduced physical, sensory or mental capabilities, or lack of experience and knowledge, unless they have been given supervision concerning use of the appliance by a person responsible for their safety. Do not allow children to play with, clean or maintain this appliance without proper supervision.

⚠ Warning

Follow these precautions to prevent personal injury while operating or maintaining this equipment:

- Read this manual thoroughly before operating, installing or performing maintenance on the equipment. Failure to follow instructions in this manual can cause property damage, injury or death.
- Crush/Pinch Hazard. Keep hands clear of moving components. Components can move without warning unless power is disconnected and all potential energy is removed.
- Moisture collecting on the floor will create a slippery surface. Clean up any water on the floor immediately to prevent a slip hazard.
- Objects placed or dropped in the bin can affect human health and safety. Locate and remove any objects immediately.
- Never use sharp objects or tools to remove ice or frost. Do not use mechanical devices or other means to accelerate the defrosting process.
- When using cleaning fluids or chemicals, rubber gloves and eye protection (and/or face shield) must be worn.

⚠ DANGER

Follow these precautions to prevent personal injury during use and maintenance of this equipment:

- It is the responsibility of the equipment owner to perform a Personal Protective Equipment Hazard Assessment to ensure adequate protection during maintenance procedures.
- Do Not Store Or Use Gasoline Or Other Flammable Vapors Or Liquids In The Vicinity Of This Or Any Other Appliance. Never use flammable oil soaked cloths or combustible cleaning solutions for cleaning.
- All covers and access panels must be in place and properly secured when operating this equipment.
- Risk of fire/shock. All minimum clearances must be maintained. Do not obstruct vents or openings.
- Failure to disconnect power at the main power supply disconnect could result in serious injury or death. The power switch DOES NOT disconnect all incoming power.
- All utility connections and fixtures must be maintained in accordance with the authority having jurisdiction.
- Turn off and lockout all utilities (electric, water) according to approved practices during maintenance or servicing.
- Never use a high-pressure water jet for cleaning on the interior or exterior of this unit. Do not use power cleaning equipment, steel wool, scrapers or wire brushes on stainless steel or painted surfaces.
- Two or more people are required to move this equipment to prevent tipping.
- These units must be tethered/secured to comply with all applicable codes.
- The on-site supervisor is responsible for ensuring that operators are made aware of the inherent dangers of operating this equipment.
- Do not operate any appliance with a damaged cord or plug. All repairs must be performed by a qualified service company.

Table of Contents

Safety Notices

Safety Notices	3
Definitions	3

Section 1

General Information

Model/Serial Number Location	7
Owner Warranty Registration Card	8
General	8
Commercial Warranty Coverage	8
Authorized Warranty Service	8
Service Calls	8
Residential Warranty Coverage	9

Section 2

Installation

General	11
Dimensions	11
Location of Ice Machine	12
Ice Machine Heat of Rejection	12
Leveling the Ice Machine	12
Electrical Service	13
Voltage	13
Fuse/Circuit Breaker	13
Electrical Rating	13
Electrical Cord Strain Relief	14
Terminal Block Wire Connection	14
Water Service/Drains	15
Water Supply	15
Drain Connections	15
Water Supply And Drain Line Sizing/Connections	15

**Section 3
Operation**

Sequence of Operation 17
 Initial Start-Up or Start-Up after Automatic Shut-Off 17
Ice Thickness Adjustment 18

**Section 4
Maintenance**

Interior Cleaning and Sanitizing 19
 General 19
 Cleaning And Sanitizing Procedure 19
Exterior Cleaning 21
Ice Machine Inspection..... 21
Cleaning the Condenser..... 22
Removal from Service/Winterization 22

**Section 5
Troubleshooting**

Checklist..... 23

Section 1

General Information

Model/Serial Number Location

Record the model and serial number of your ice machine in the space provided below. These numbers are required when requesting information from your Manitowoc distributor, service representative or the factory.

The model and serial number are listed on the OWNER WARRANTY REGISTRATION CARD. They are also listed on the MODEL/SERIAL NUMBER DECAL affixed to the ice machine.

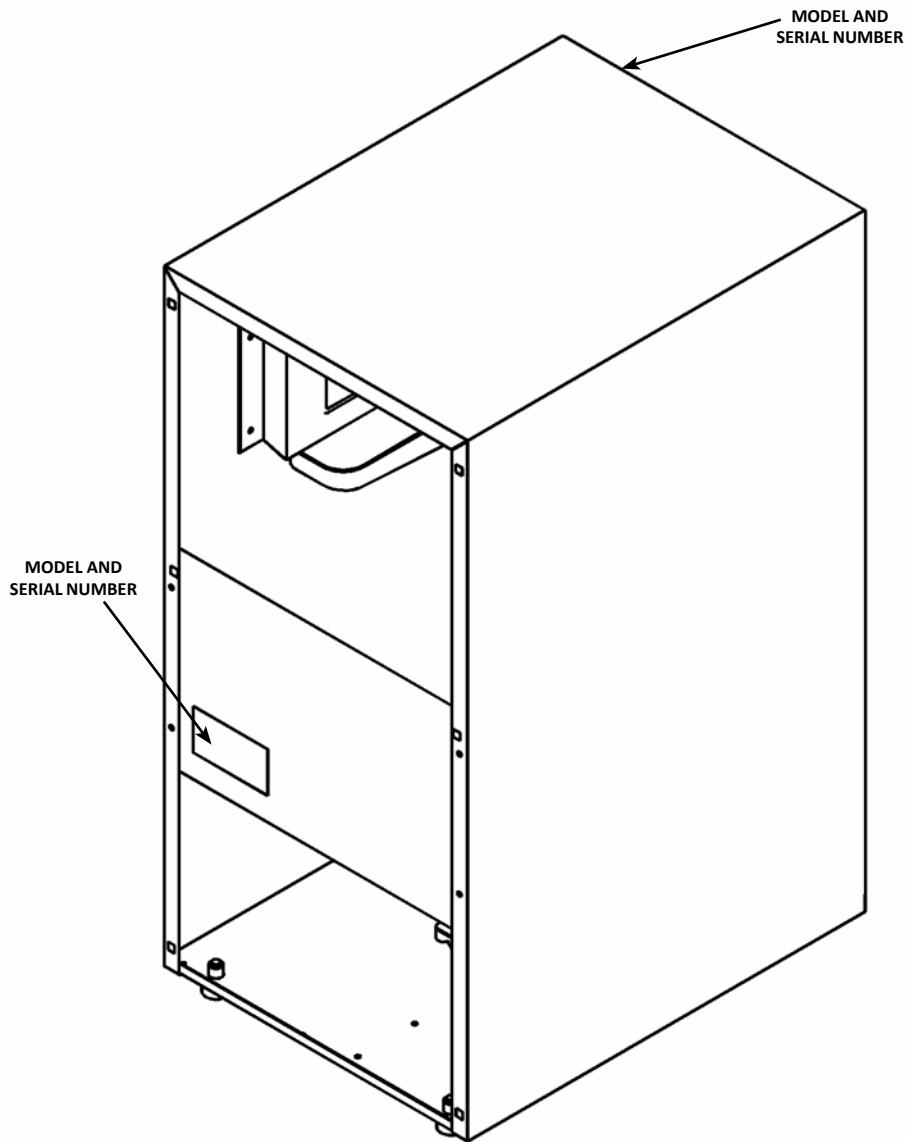

Model/Serial Number Location

Model Number: _____

Serial Number: _____

Owner Warranty Registration Card

GENERAL

The packet containing this manual also includes warranty information. Warranty coverage begins the day your new ice machine is installed.

Important

Complete and mail the OWNER WARRANTY REGISTRATION CARD as soon as possible to validate the installation date.

If you do not return your OWNER WARRANTY REGISTRATION CARD, Manitowoc will use the date of sale to the Manitowoc Distributor as the first day of warranty coverage for your new ice machine.

COMMERCIAL WARRANTY COVERAGE

General

The following Warranty outline is provided for your convenience. For a detailed explanation, read the warranty bond shipped with each product.

Contact your local Manitowoc representative or Manitowoc Ice, Inc. if you need further warranty information.

Parts

Manitowoc warrants the ice machine against defects in materials and workmanship, under normal use and service for three (3) years from the date of original installation.

Labor

Labor required to repair or replace defective components is covered for three (3) years from the date of original installation.

Exclusions

The following items are not included in the ice machine's warranty coverage:

1. Normal maintenance, adjustments and cleaning as outlined in this manual.
2. Repairs due to unauthorized modifications to the ice machine or use of non-standard parts without prior written approval from Manitowoc Ice, Inc.
3. Damage caused by improper installation of the ice machine, electrical supply, water supply or drainage, or damage caused by floods, storms, or other acts of God.
4. Premium labor rates due to holidays, overtime, etc.; travel time; flat rate service call charges; mileage and miscellaneous tools and material charges not listed on the payment schedule. Additional labor charges resulting from the inaccessibility of equipment are also excluded.
5. Parts or assemblies subjected to misuse, abuse, neglect or accidents.
6. Damage or problems caused by installation, cleaning and/or maintenance procedures inconsistent with the technical instructions provided in this manual.

AUTHORIZED WARRANTY SERVICE

To comply with the provisions of the warranty, a refrigeration service company, qualified and authorized by your Manitowoc distributor, or a Contracted Service Representative must perform the warranty repair.

NOTE: If the dealer you purchased the ice machine from is not authorized to perform warranty service, contact your Manitowoc distributor or Manitowoc Ice, Inc. for the name of the nearest authorized service representative.

SERVICE CALLS

Normal maintenance, adjustments and cleaning as outlined in this manual are not covered by the warranty. If you have followed the procedures listed in this manual, and the ice machine still does not perform properly, call your authorized service company.

RESIDENTIAL WARRANTY COVERAGE**WHAT DOES THIS LIMITED WARRANTY COVER?**

Subject to the exclusions and limitations below, Manitowoc Ice, Inc. (“Manitowoc”) warrants to the original consumer that any new ice machine manufactured by Manitowoc (the “Product”) shall be free of defects in material or workmanship for the warranty period outlined below under normal use and maintenance, and upon proper installation and start-up in accordance with the instruction manual supplied with the Product.

HOW LONG DOES THIS LIMITED WARRANTY LAST?

Ice Machine - Twelve (12) months from the sale date.

WHO IS COVERED BY THIS LIMITED WARRANTY?

This limited warranty only applies to the original consumer of the Product and is not transferable.

WHAT ARE MANITOWOC ICE’S OBLIGATIONS UNDER THIS LIMITED WARRANTY?

If a defect arises and Manitowoc receives a valid warranty claim prior to the expiration of the warranty period, Manitowoc shall, at its option: (1) repair the Product at Manitowoc’s cost, including standard straight time labor charges, (2) replace the Product with one that is new or at least as functionally equivalent as the original, or (3) refund the purchase price for the Product.

Replacement parts are warranted for 90 days or the balance of the original warranty period, whichever is longer. The foregoing constitutes Manitowoc’s sole obligation and the consumer’s exclusive remedy for any breach of this limited warranty. Manitowoc’s liability under this limited warranty is limited to the purchase price of Product. Additional expenses including, without limitation, service travel time, overtime or premium labor charges, accessing or removing the Product, or shipping are the responsibility of the consumer.

HOW TO OBTAIN WARRANTY SERVICE

To obtain warranty service or information regarding your Product, please contact us at:

MANITOWOC ICE
2110 So. 26th St.,
P.O. Box 1720,
Manitowoc, WI 54221-1720
Telephone: 920-682-0161 Fax: 920-683-7585
www.welbilt.com

WHAT IS NOT COVERED?

This limited warranty does not cover, and you are solely responsible for the costs of: (1) periodic or routine maintenance, (2) repair or replacement of the Product or parts due to normal wear and tear, (3) defects or damage to the Product or parts resulting from misuse, abuse, neglect or accidents, (4) defects or damage to the Product or parts resulting from improper or unauthorized alterations, modifications or changes; and (5) defects or damage to any Product that has not been installed and/or maintained in accordance with the instruction manual or technical instructions provided by Manitowoc. To the extent that warranty exclusions are not permitted under some state laws, these exclusions may not apply to you.

EXCEPT AS STATED IN THE FOLLOWING SENTENCE, THIS LIMITED WARRANTY IS THE SOLE AND EXCLUSIVE WARRANTY OF MANITOWOC WITH REGARD TO THE PRODUCT. ALL IMPLIED WARRANTIES ARE STRICTLY LIMITED TO THE DURATION OF THE LIMITED WARRANTY APPLICABLE TO THE PRODUCTS AS STATED ABOVE, INCLUDING BUT NOT LIMITED TO, ANY WARRANTY OF MERCHANTABILITY OR OF FITNESS FOR A PARTICULAR PURPOSE. Some states do not allow limitations on how long an implied warranty lasts, so the above limitation may not apply to you.

IN NO EVENT SHALL MANITOWOC OR ANY OF ITS AFFILIATES BE LIABLE TO THE CONSUMER OR ANY OTHER PERSON FOR ANY INCIDENTAL, CONSEQUENTIAL OR SPECIAL DAMAGES OF ANY KIND (INCLUDING, WITHOUT LIMITATION, LOSS OF PROFITS, REVENUE OR BUSINESS) ARISING FROM OR IN ANY MANNER CONNECTED WITH THE PRODUCT, ANY BREACH OF THIS LIMITED WARRANTY OR ANY OTHER CAUSE WHATSOEVER, WHETHER BASED ON CONTRACT, TORT OR ANY OTHER THEORY OF LIABILITY. Some states do not allow the exclusion or limitation of incidental or consequential damages, so the above limitation or exclusion may not apply to you.

HOW STATE LAW APPLIES

This limited warranty gives you specific legal rights, and you may also have rights that vary from state to state or from one jurisdiction to another.

REGISTRATION CARD

To secure prompt and continuing warranty service, this warranty registration card must be completed and sent to Manitowoc within thirty (30) days from the sale date. Complete the following registration card and send it to Manitowoc at the address shown.

THIS PAGE INTENTIONALLY LEFT BLANK

Section 2 Installation

General

These instructions are provided to assist the qualified installer.

Dimensions

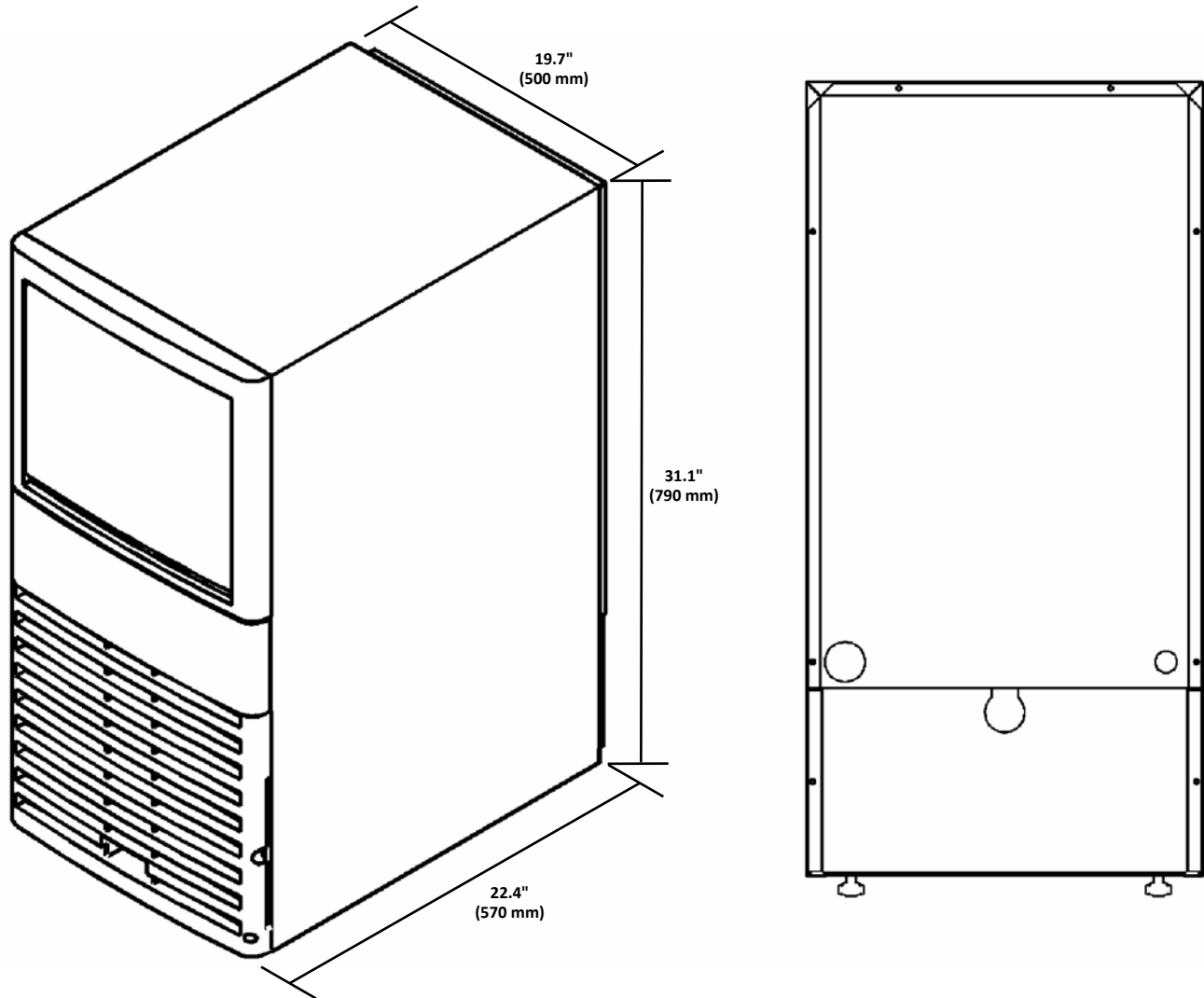

Location of Ice Machine

The location selected for the ice machine must meet the following criteria. If any of these criteria are not met, select another location.

- The location must be indoors.
- The location must be free of airborne and other contaminants.
- The air temperature must be at least 50°F (10°C), but must not exceed 104°F (40°C).
- The location must not be near heat-generating equipment or in direct sunlight.
- The location must be capable of supporting the weight of the ice machine and a full bin of ice.
- The location must allow enough clearance for water, drain and electrical connections in the **rear of the ice machine**.
- The location must not obstruct airflow through or around the ice machine (condenser airflow is in and out the front). Refer to the chart below for clearance requirements.

	Self-Contained Air-Cooled
Top/Sides	5" (127 mm)
Back	5" (127 mm)

NOTE: The ice machine may be built into a cabinet.

There is no minimum clearance requirement for the top or left and right sides of the ice machine. The listed values are recommended for efficient operation and servicing only.

Notice
The ice machine must be protected if it will be subjected to temperatures below 32°F (0°C). Failure caused by exposure to freezing temperatures is not covered by the warranty. See "Removal from Service/Winterization" Section 4.

Ice Machine Heat of Rejection

Series Ice Machine	Heat of Rejection*	
	Air Conditioning**	Peak
UDE0065A	1600	2350

*B.T.U./Hour.

** Because the heat of rejection varies during the ice making cycle, the figure shown is an average.

Ice machines, like other refrigeration equipment, reject heat through the condenser. It is helpful to know the amount of heat rejected by the ice machine when sizing air conditioning equipment where self-contained aircooled ice machines are installed.

Leveling the Ice Machine

After moving the ice machine into the installation location, it must be leveled for proper operation. Follow these steps to level the ice machine:

1. Check the level of the ice machine from front to back and from side to side.

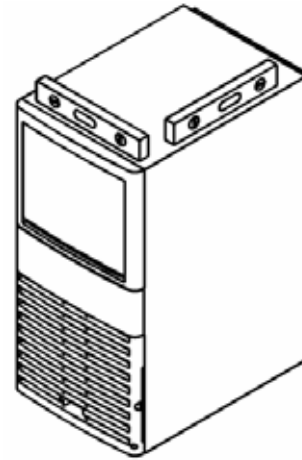

Checking for Level

2. If the ice machine is not level, adjust the leveling glides on each corner of the base of the ice machine as necessary.

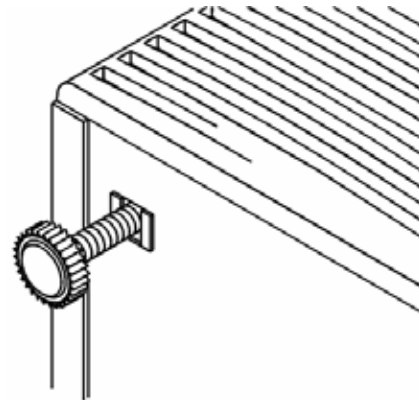

Leveling Glide

3. Check the level of the ice machine after each adjustment of the leveling glides.
4. Repeat steps 2 and 3 until the ice machine is level from front to back and from side to side.

Electrical Service

⚠ Warning

All wiring must conform to local, state and national codes.

Voltage/Phase	Electrical Rating
230/50/1	0.6 kW
230/60/1	0.6 kW
115/60/1	0.6 kW

VOLTAGE

The maximum allowable voltage variation is $\pm 10\%$ of the rated voltage on the ice machine model/serial number plate at start-up (when the electrical load is highest).

⚠ Warning

The ice machine must be grounded in accordance with national and local electrical codes.

⚠ Warning

Never use an extension cord. If an outlet is not within reach of the ice machine's power cord, have a proper amperage outlet wired closer to the ice machine.

FUSE/CIRCUIT BREAKER

A separate fuse/circuit breaker must be provided for each ice machine.

NOTE: A disconnect means must be provided for field wiring.

ELECTRICAL RATING

The electrical rating is used to help select the wire size of the electrical supply. The wire size (or gauge) also depends on location, materials used, length of run, etc., so it must be determined by a qualified electrician.

ELECTRICAL CORD STRAIN RELIEF

To prevent strain at the electrical connection inside the ice machine, an electrical cord strain relief device must be installed on the rear panel of the ice machine.

1. Disassemble the strain relief device into its three components.
2. Install the cord holder through the opening in the lower right corner of the rear panel of the ice machine.

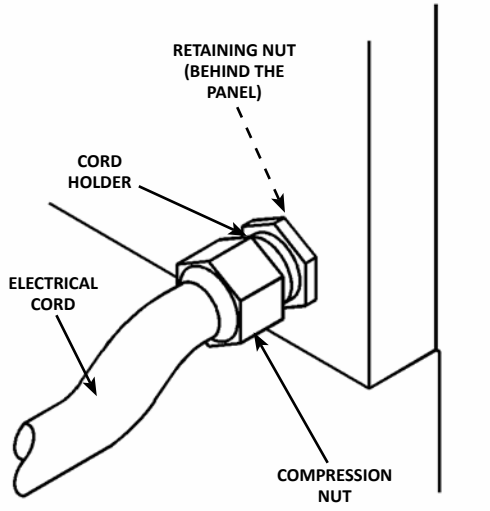

Strain Relief Installation

3. Hand-tighten the retaining nut onto the cord holder from inside the ice machine rear panel.
4. Slide the compression nut over the electrical cord.
5. Feed about 5 ft. (1.5 m) of electrical cord through the cord holder. (The extra cord will allow the rear panel to be removed for future service.)
6. Hand-tighten the compression nut onto the cord holder.

TERMINAL BLOCK WIRE CONNECTION

⚠ Warning

Always disconnect power to the ice machine before working on electrical circuitry.

After the electrical cord is installed in the strain relief device, the cord must be connected to the terminal block to supply power to the ice machine.

1. Remove two Phillips head screws to remove the lower panel from the front of the ice machine.
2. Carefully reach into the ice machine and pull the electrical cord forward to the terminal block.
3. Strip away enough insulation from the electrical cord to allow for good electrical connections at the terminal block.

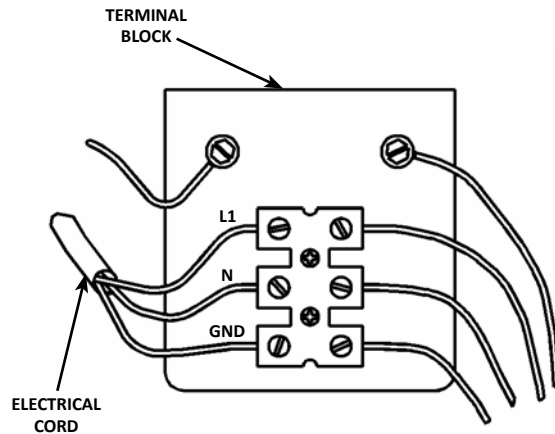

Terminal Block Connections

4. Open the screw terminals on the terminal block.
5. Connect each wire in the electrical cord to the appropriate screw terminal.
6. Carefully tighten the screws over the wire.
7. Tug lightly on each wire to be sure the connections are secure.

Water Service/Drains

WATER SUPPLY

Local water conditions may require treatment of the water to inhibit scale formation, filter sediment, remove chlorine, and improve taste and clarity.

Important

If you are installing a Manitowoc Tri-Liminator water filter system, refer to the Installation Instructions supplied with the filter system for ice making water inlet connections.

Follow these guidelines to install water inlet lines:

- Connect to potable water supply only.
- Do not connect the ice machine to a hot water supply. Be sure all hot water restrictors installed for other equipment are working. (Check valves on sink faucets, dishwashers, etc.)
- If water pressure exceeds the maximum recommended pressure, obtain a water pressure regulator from your Manitowoc distributor.

- Install a water shut-off valve for both the ice making and condenser water lines (if applicable).
- Insulate water lines to prevent condensation.

Important

The water inlet line is connected to the water valve. This valve is located just behind the front panel of the ice machine.

DRAIN CONNECTIONS

Follow these guidelines when installing drain lines to prevent drain water from flowing back into the ice machine and storage bin:

- Drain lines must have a 1" drop per 40" (2.5 cm per meter) of run, and must not create traps.
- The floor drain must be large enough to accommodate drainage from all drains.
- Insulate the bin drain line to prevent condensation.

WATER SUPPLY AND DRAIN LINE SIZING/CONNECTIONS

⚠ Caution

Plumbing must conform to state and local codes.

	Water Temperature	Water Pressure	Ice Machine Fitting	Tubing Size Up to Ice Machine Fitting
Ice Making Water Inlet	50°F (10°C)Min. ¹ 86°F (30°C)Max. ²	34.8 psi (240 kPa)Min. ¹ 89.9 psi (620 kPa)Max. ²	3/4" male hose connection ³	3/8" (9.5 mm) minimum inside diameter
Ice Making/Bin Water Drain	—	—	5/8" (16 mm) inside diameter flexible hose	5/8" (16 mm) minimum inside diameter

¹ Min. = Minimum.

² Max. = Maximum.

³ A 3/4" by 11-1/2 threads per inch to 14 threads per inch adapter is factory installed. Remove this adapter if 11-1/2 threads per inch connection is desired.

Installation Note (Switzerland) The connection to the drinking water network must be made with a certified backflow preventer type EA (EN13959) and with a certified connection hose (EN13618 or EN61770) on site.

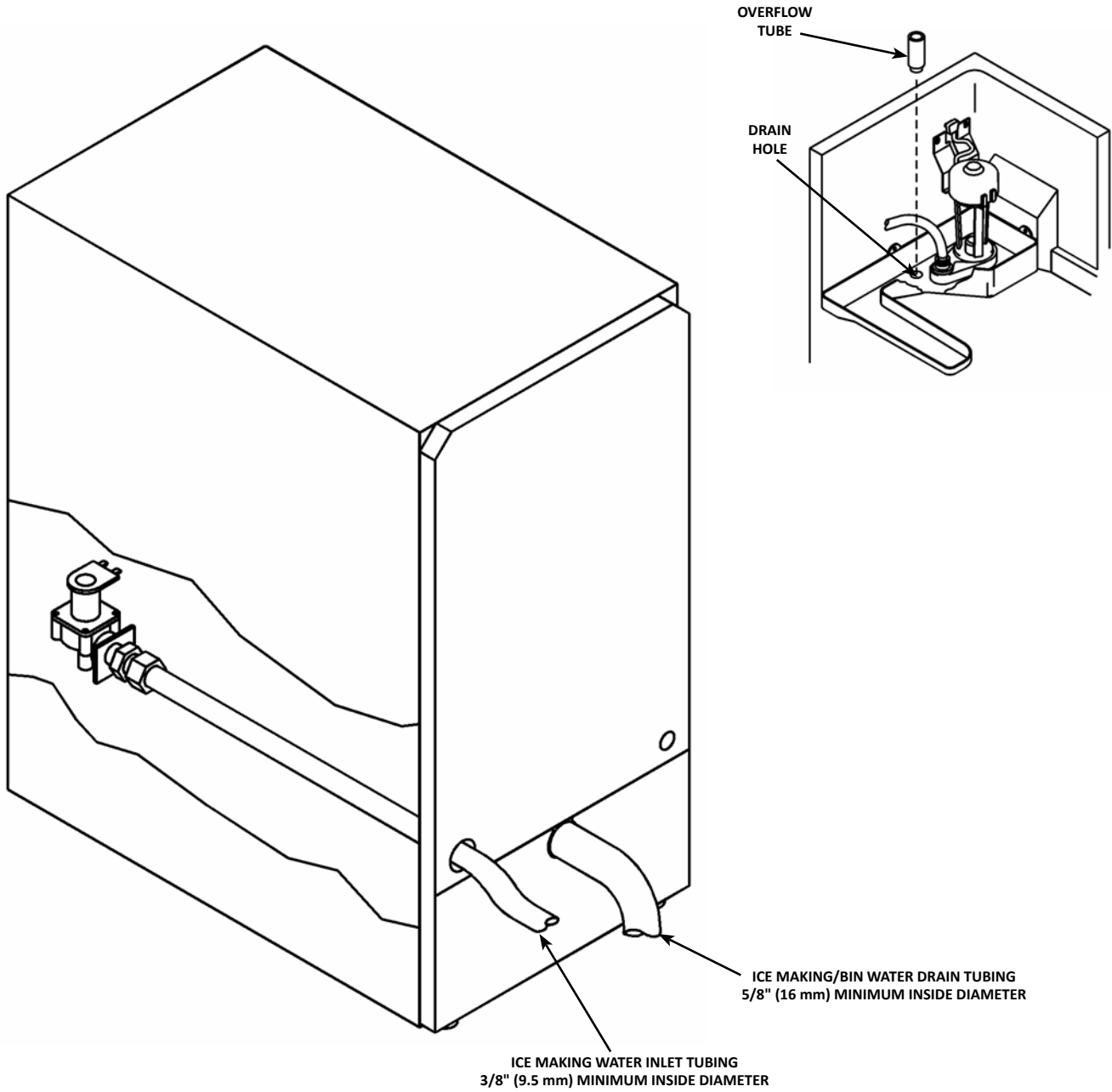

Typical Water Supply and Drain Line Sizing and Connections

Section 3 Operation

Sequence of Operation

Ice Making Sequence of Operation	Control Board Relays			Length of "ON" Time
	1 Compressor	2 Hot Gas Valve Water Fill Valve	3 Water Pump Fan Motor	
Start-up*	off	on	on	2.9 Minutes (175 Seconds)
1. Water Purge 2. Refrigeration System Start-up	on	on	off	5 Seconds
3. Freeze Cycle	on	off	on	Automatically determined
4. Harvest Cycle	on	on	off	Automatically determined
5. Auto Shut-off	off	off	off	Until bin thermostat re-closes

*Initial Start-up or Start-up After Automatic Shut-off.

INITIAL START-UP OR START-UP AFTER AUTOMATIC SHUT-OFF

1. Water Purge

The water fill valve and the hot gas valve are energized for 2.9 minutes (175 seconds). This ensures that the ice making cycle starts with fresh water, and that the refrigerant pressures are equalized prior to refrigeration system start-up.

2. Refrigeration System Start-up

The compressor starts 2.9 minutes (175 seconds) after the water fill valve and hot gas valve are energized. (The water fill valve and hot gas valve remain energized for 5 seconds during compressor start-up, and then shut off.) The compressor remains on throughout the entire freeze and harvest cycles.

3. Freeze Cycle

The condenser fan motor and water pump are energized and remain on throughout the entire freeze cycle. An even flow of water is directed across the evaporator and into each cube cell, where it freezes.

The control system automatically determines the length of the freeze cycle by monitoring the temperature of the refrigeration system liquid line.

4. Harvest Cycle

The condenser fan motor and water pump de-energize. The water fill valve energizes to purge the water in the water trough. The hot gas valve also energizes at the beginning of the harvest cycle to divert hot refrigerant gas into the evaporator. The hot refrigerant gas warms the evaporator, causing the cubes to slide, as a sheet, off the evaporator and into the ice storage bin.

The control system automatically determines the length of the harvest cycle, based on the temperature of the refrigeration system liquid line at the end of the freeze cycle. At the end of the harvest cycle, the ice machine returns to another freeze cycle.

5. Automatic Shut-off

The ice machine shut-off is controlled by the level of ice in the ice storage bin. When the bin is full, ice cubes contact the bin thermostat bulb holder, which cools down and opens to stop the ice machine. The ice machine remains off until enough ice has been removed from the bin. This causes the thermostat bulb holder to warm and close, restarting the ice machine. When the ice machine restarts, it returns to the start-up sequence.

Ice Thickness Adjustment

QM-20 dice ice cube formation is slightly different from our previous models. Manitowoc ice machines have a unique cube shape. It is normal to have a dimple in the ice cube (a concave indentation in the cube). Ice cubes from the QM-20 may appear to have a slightly larger dimple than other Manitowoc dice cube machines. Therefore, cube size for the QM-20 is determined by measuring the slab weight (the combined weight of all cubes from one harvest cycle). To determine proper slab weight follow the instructions listed below.

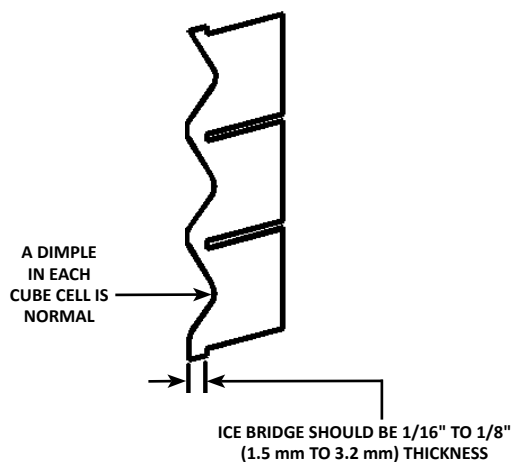

Correct Ice Bridge Thickness

1. Ensure the air filter, front, and back panels are installed properly and close the bin door.
2. During the third harvest cycle open the bin door and catch the entire slab of ice.
3. Weigh the ice slab. The combined weight of all cubes from one harvest should weigh between 7 and 9 oz (200 and 270g). If the slab weight is within this range, the ice machine is working properly and no further action is needed. If the slab weight is not within this range or you desire a slightly thicker or thinner cube, continue to step four.

⚠ Warning

Do not touch electrical wires. Disconnect power to the ice machine before making any ice thickness adjustments.

4. Remove the air filter.
5. Remove the two screws holding the front panel in place and remove the front cover.
6. Locate the ice thickness control dial on the control board (see below). Turn the dial clockwise for a thicker cube or counter clockwise for a thinner cube.

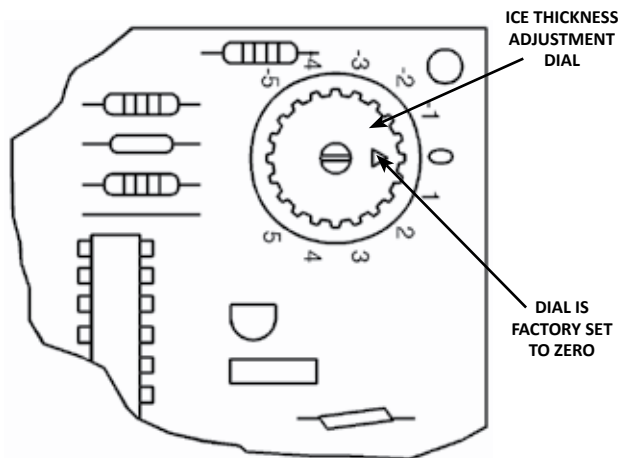

Ice Thickness Adjustment Dial

7. Ensure all of the panels and air filter are reinstalled properly and the bin door is closed. Repeat steps 1 through 3.

After completing the procedure above, if you are unable to obtain a sheet of ice weighing 7 to 9 oz (200 to 270g) contact the Welbilt Service Department for further assistance.

Section 4 Maintenance

Interior Cleaning and Sanitizing

GENERAL

Clean and sanitize the ice machine every six months for efficient operation. If the ice machine requires more frequent cleaning and sanitizing, consult a qualified service company to test the water quality and recommend appropriate water treatment.

The ice machine must be taken apart for cleaning and sanitizing.

⚠ Caution

Use only Manitowoc approved Ice Machine Cleaner (part number 94-0546-3) and Sanitizer (part number 94-0565-3). It is a violation of Federal law to use these solutions in a manner inconsistent with their labeling. Read and understand all labels printed on bottles before use.

CLEANING AND SANITIZING PROCEDURE

⚠ Caution

Do not mix Ice Machine Cleaner and Sanitizer solutions together. It is a violation of Federal law to use these solutions in a manner inconsistent with their labeling.

⚠ Warning

Wear rubber gloves and safety goggles (and/or face shield) when handling Ice Machine Cleaner or Sanitizer.

Ice machine cleaner is used to remove lime scale and mineral deposits. Ice machine sanitizer disinfects and removes algae and slime.

Step 1 Set the toggle switch to the OFF position after ice falls from the evaporator at the end of a Harvest cycle. Or, set the switch to the OFF position and allow the ice to melt off the evaporator.

Notice

Never use anything to force ice from the evaporator. Damage may result.

Step 2 Remove all ice from the bin.

Step 3 To start a cleaning cycle, move the toggle switch to the WASH position.

Step 4 Wait until water flows over the evaporator (about three minutes) then add the proper amount of Manitowoc Ice Machine Cleaner to the water trough.

Model	Amount of Cleaner
U65	1.5 oz (45 ml)

Step 5 Wait until the clean cycle is complete (approximately 45 minutes) then place the toggle switch in the OFF position, disconnect power and water supplies to the ice machine.

⚠ Warning

Disconnect electric power to the ice machine at the electric switch box before proceeding.

Step 6 Remove parts for cleaning.

A. Remove the Overflow Tube

- To remove the tube, lift it up while using a slight back and forth motion to loosen it from the drain hole.

When installing the tube, be sure it is completely inserted into the drain hole to prevent water leakage during normal operation.

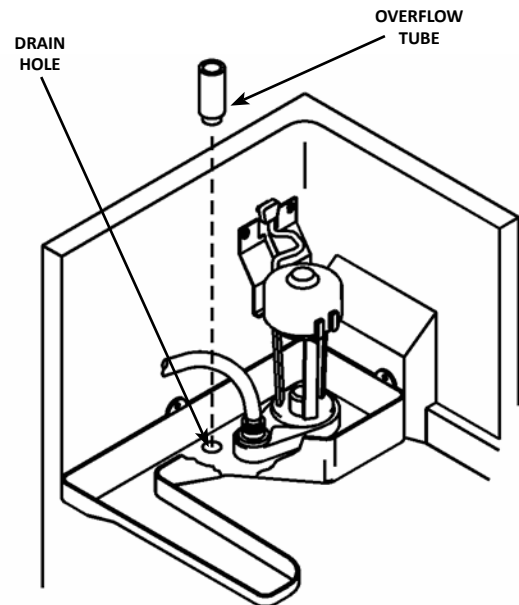

Removing the Overflow Tube

B. Remove the Vinyl Hose

- Disconnect the water pump discharge hose from the distribution tube and water pump.

C. Remove the Water Pump

- Disconnect the water pump power cord.
- Loosen the screws that hold the water pump in place.
- Lift the water pump and bracket assembly up and off the screws.

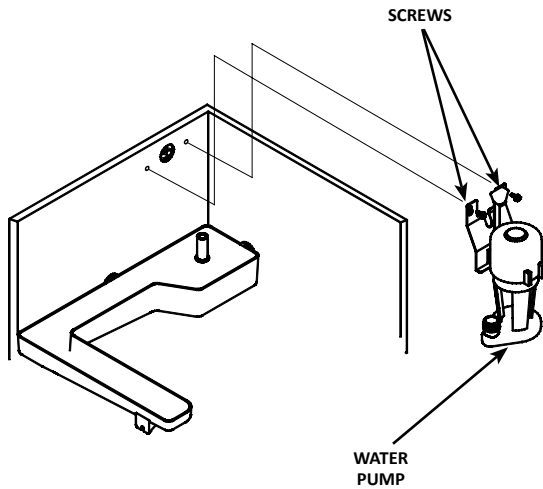

Removing the Water Pump

D. Remove the Water Trough

- Remove the screws holding the water trough to the walls of the cabinet.

Step 7 Mix a solution of cleaner and warm water. Depending on the amount of mineral buildup, a larger quantity of solution may be required. Use the ratio in the table below to mix enough solution to thoroughly clean all parts.

Solution Type	Water	Mixed with
Cleaner	1 gal (4 L)	16 oz (500 ml) cleaner

Step 8 Use 1/2 of the cleaner/water solution to clean all components. The cleaner solution will foam when it contacts lime scale and mineral deposits; once the foaming stops use a soft bristle brush, sponge or cloth (not a wire brush) to carefully clean the parts. Soak the parts for 5 minutes (15 – 20 minutes for heavily scaled parts). Rinse all components with clean water.

Step 9 While components are soaking, use 1/2 of the cleaner/water solution to clean all foodzone surfaces of the ice machine and bin. Use a nylon brush or cloth to thoroughly clean the following ice machine areas:

- Evaporator plastic parts – including top, bottom and sides
- Bin bottom, sides and top

Rinse all areas thoroughly with clean water.

Step 10 Mix a solution of sanitizer and warm water.

Solution Type	Water	Mixed With
Sanitizer	6 gal (23 L)	4 oz (120 ml) sanitizer

Step 11 Use 1/2 of the sanitizer/water solution to sanitize all removed components. Use a cloth or sponge to liberally apply the solution to all surfaces of the removed parts or soak the removed parts in the sanitizer/water solution. Do not rinse parts after sanitizing.

Step 12 Use 1/2 of the sanitizer/water solution to sanitize all foodzone surfaces of the ice machine and bin. Use a cloth or sponge to liberally apply the solution. When sanitizing, pay particular attention to the following areas:

- Evaporator plastic parts – including top, bottom and sides
- Bin bottom, sides and top

Do not rinse the sanitized areas.

Step 13 Replace all removed components.

Step 14 Reapply power and water to the ice machine and place the toggle switch in the WASH position.

Step 15 Add the proper amount of Manitowoc Ice Machine Sanitizer to the water trough.

Model	Amount of Sanitizer
U65	1.5 oz (45 ml)

Step 16 Wait until the sanitize cycle is complete (approximately 45 minutes) then place the toggle switch in the OFF position, disconnect power and water supplies to the ice machine.

⚠ Warning

Disconnect electric power to the ice machine at the electric switch box before proceeding.

Step 17 Repeat step 6 to remove parts for hand sanitizing.

Step 18 Mix a solution of sanitizer and warm water.

Solution Type	Water	Mixed With
Sanitizer	6 gal (23 L)	4 oz (120 ml) sanitizer

Step 19 Use 1/2 of the sanitizer/water solution to sanitize all removed components. Use a cloth or sponge to liberally apply the solution to all surfaces of the removed parts or soak the removed parts in the sanitizer/water solution. Do not rinse parts after sanitizing.

Step 20 Use 1/2 of the sanitizer/water solution to sanitize all foodzone surfaces of the ice machine and bin. Use a cloth or sponge to liberally apply the solution. When sanitizing, pay particular attention to the following areas:

- Evaporator plastic parts – including top, bottom and sides
- Bin bottom, sides and top

Do not rinse the sanitized areas.

Step 21 Replace all removed components.

Step 22 Reapply power and water to the ice machine and place the toggle switch in the ICE position.

Exterior Cleaning

Clean the area around the ice machine as often as necessary to maintain cleanliness and efficient operation.

Sponge any dust and dirt off the outside of the ice machine with mild soap and water. Wipe dry with a clean, soft cloth.

Treat all exterior stainless steel surfaces with a commercial grade stainless steel cleaner/polish.

Ice Machine Inspection

Check all water fittings and lines for leaks. Also, make sure the refrigeration tubing is not rubbing or vibrating against other tubing, panels, etc.

Do not put anything (boxes, etc.) in front of the ice machine. There must be adequate airflow through and around the ice machine to maximize ice production and ensure long component life.

Cleaning the Condenser

Warning

Disconnect electric power to the ice machine at the electric service switch before cleaning the condenser.

A dirty condenser restricts airflow, resulting in excessively high operating temperatures. This reduces ice production and shortens component life. Clean the condenser at least every six months. Follow the steps below.

Caution

The condenser fins are sharp. Use care when cleaning them.

1. The washable aluminum filter on self-contained ice machines is designed to catch dust, dirt, lint and grease. This helps keep the condenser clean. Clean the filter with a mild soap and water solution.

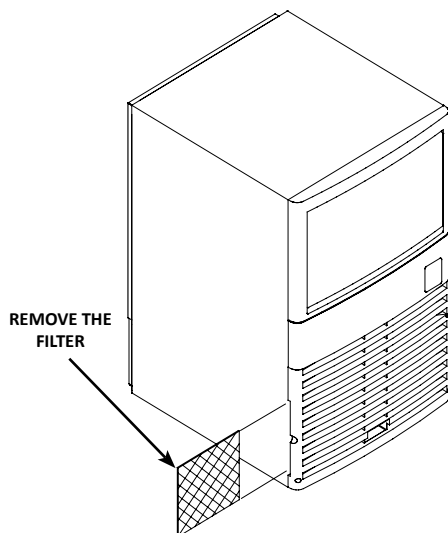

Removing the Filter

2. Clean the outside of the condenser with a soft brush or a vacuum with a brush attachment. Clean from top to bottom, not side to side. Be careful not to bend the condenser fins.

3. Shine a flashlight through the condenser to check for dirt between the fins. If dirt remains: Blow compressed air through the condenser fins from the inside. Be careful not to bend the fan blades.
4. Use a commercial condenser coil cleaner. Follow the directions and cautions supplied with the cleaner.
5. Straighten any bent condenser fins with a fin comb.
6. Carefully wipe off the fan blades and motor with a soft cloth. Do not bend the fan blades. If the fan blades are excessively dirty, wash with warm, soapy water and rinse thoroughly.

Notice

If you are cleaning the condenser fan blades with water, cover the fan motor to prevent water damage.

Removal from Service/Winterization

Special precautions must be taken if the ice machine is to be removed from service for an extended period of time or exposed to ambient temperatures of 32°F (0°C) or below.

Notice

If water is allowed to remain in the ice machine in freezing temperatures, severe damage to some components could result. Damage of this nature is not covered by the warranty.

1. Disconnect the electric power at the circuit breaker or the electric service switch.
2. Turn off the water supply.
3. Remove the water from the water trough.
4. Disconnect the drain and the incoming ice-making water line at the rear of the ice machine.
5. Make sure no water is trapped inside the ice machine incoming water lines, drain lines, distribution tubes, etc. Blow compressed air through the line if necessary.

Section 5 Troubleshooting

Checklist

If a problem arises during operation of your ice machine, follow the checklist below before calling for service.

Problem	Possible Cause	To Correct
Ice machine does not operate	No electrical power to the ice machine	Replace the fuse/reset the breaker/turn on the main switch.
	Toggle switch set improperly	Move toggle switch to the ON position.
	Low air temperature around ice machine	Air temperature must be at least 50°F (10°C).
Ice machine does not release ice or is slow to harvest	Ice machine is dirty	Clean and sanitize the ice machine.
	Ice machine is not level	Level the ice machine.
	Low air temperature around ice machine	Air temperature must be at least 50°F (10°C).
Ice quality is poor	Poor incoming water quality	Contact a qualified service company to test the quality of the incoming water and make appropriate filter recommendations.
	Water filtration is poor	Replace filter.
	Ice machine is dirty	Clean and sanitize the ice machine.
	Water inlet valve filter screen is dirty	Remove the water inlet valve and clean the filter screen.
	Water softener is working improperly (if applicable)	Repair the water softener.
Ice machine produces shallow or incomplete cubes, or the ice fill pattern on the evaporator is incomplete	Water level is low	Be sure the overflow tube is fully seated to prevent water leakage.
	Water inlet valve filter screen is dirty	Remove the water inlet valve and clean the filter screen.
	Water filtration is poor	Replace the filter.
	Hot incoming water	Connect the ice machine to a cold water supply.
	Ice thickness adjustment dial is not set properly	Adjust the ice thickness adjustment dial.
	Incorrect incoming water pressure	Water pressure must be 34.8 - 89.9 psi (240-620 kPa).
	Ice machine is not level	Level the ice machine.
Low ice capacity	Water inlet valve filter screen is dirty	Remove the water inlet valve and clean the filter screen.
	Incoming water supply is shut off	Open the water service valve.
	The air filter is dirty	Clean the air filter.
	The condenser is dirty	Clean the condenser.
	Inadequate airflow at the front of the ice machine	Remove items blocking airflow at the front of the ice machine.
	Ice thickness adjustment dial is not set properly	Adjust the ice thickness adjustment dial.

THIS PAGE INTENTIONALLY LEFT BLANK



MANITOWOC ICE
2110 SOUTH 26TH STREET, MANITOWOC, WI 54220

800-545-5720
WWW.MANITOWOCICE.COM