



a Standex company

ITEM: _____ PROJECT NAME: _____ DATE: _____

MARKET SERIES HOT DELI CASE

- MODEL SQ-3HD
 SQ-4HD
 SQ-6HD
 SQ-8HD



Panel base shown

*Market Deli. The low profile merchandiser that provides solutions to your fresh food merchandising needs. Cases are available in lengths of 3', 4', 6', and 8'.
Designed for continuous case line-ups without middle end glass.*

STANDARD FEATURES

- Lift-up, pneumatic, cylinder-assisted curved front glass.
- Four-point leveling system.
- Rear work counter.
- Top-mounted heater and lights.
- Pedestal or panel base design.
- Tempered front and end glass.
- **Removable rear door assembly. Doors not required for operation.**
- Designed for continuous case line-ups.
- Stainless steel exterior and interior finish.
- Solid-state control panel with main power, light, zone well heaters, humidity and overhead heater settings. Panel also includes time and temperature readout.
- Zone heater controls.
- Appliance receptacle provided on back for cash register, scale, or slicer.
- Auto water fill.
- Humidified circulating air flow maintains ideal product moisture.
- UL & UL Sanitation Listed.
- Drain not required.

MARKET SERIES HOT DELI CASE

OPTIONAL ACCESSORIES:

- Special Case Height (50" or 52")
- Front Bumper Rail (Black, White, Green, Gray)
- Reflective End Glass
- Decorative End Panel
(Black, White, Green, Gray)
- Scale Stand
- Food Container Holder
- Top Service Shelf
- Accent Base Light
- Slicer Stand
- Non-Glare Glass

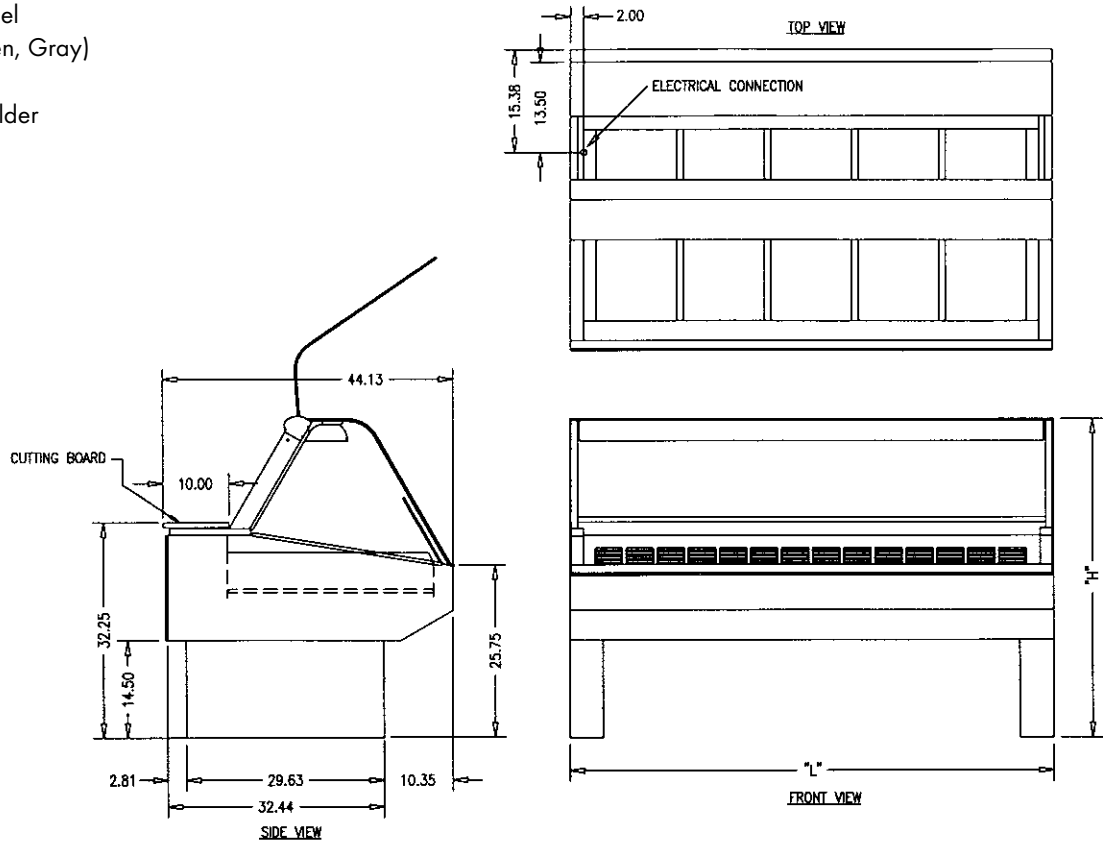

SPECIFICATIONS:

Model	*Dimensions L W H	Approx. Shipping Weight (lbs)	**AMPS 208-240/60/1 3 Wire Plus Ground	Water Connections	***Well Capacity
<input type="checkbox"/> SQ-3HD	36" x 44 1/8" x 48"	375	10.3	1/2" NPT	2
<input type="checkbox"/> SQ-4HD	48" x 44 1/8" x 48"	470	14.6	1/2" NPT	3
<input type="checkbox"/> SQ-6HD	72" x 44 1/8" x 48"	710	22.6	1/2" NPT	5
<input type="checkbox"/> SQ-8HD	96" x 44 1/8" x 48"	920	31.2	1/2" NPT	7

* Without decorative end panel.

** Plus general receptacle 120V, 15 AMP. (2nd circuit required.) (N/A for Canadian Listings.)

*** Each well holds a full-size pan and a third.

• **When ordering, specify case line-up and pedestal or panel design.**

• Due to continuing engineering improvements, specifications are subject to change without notice.



The Signature of Quality

FEDERAL INDUSTRIES

A Standex Company

215 FEDERAL AVENUE, BELLEVILLE, WISCONSIN 53508-9201

PHONE: 800-356-4206

EMAIL: geninfo@federalind.com

FAX: 608-424-3234

WEBSITE: www.federalind.com

