



500-1D



500-1DN



500-2D



500-2DN



500-3D



500-3DN

### Hot Food Holding

- 500-1D**
- 500-2D**
- 500-3D**
- 500-1DN**
- 500-2DN**
- 500-3DN**
- 500-2DI**

- **Installation**
- **Operation**
- **Maintenance**

W164 N9221 Water Street • P.O. Box 450  
Menomonee Falls, Wisconsin 53052-0450 U.S.A.

PHONE: 262.251.3800 • 800.558.8744 U.S.A. / CANADA  
FAX: 262.251.7067 • 800.329.8744 U.S.A. ONLY  
[www.alto-shaam.com](http://www.alto-shaam.com)



Consult instructions  
for operation and use.



# Table of Contents

---

Warranty and Service Information . . . . .	3
Delivery . . . . .	4
Transportation and Damage Claims . . . . .	5
Unpacking . . . . .	6
Safety Procedures . . . . .	7
Installation . . . . .	9
Electrical Connection . . . . .	12
Operation . . . . .	13
General Holding Guidelines . . . . .	15
Cleaning and Preventative Maintenance . . . . .	16
Food Safety . . . . .	18
Troubleshooting . . . . .	19
Service . . . . .	21
Wiring Diagrams . . . . .	31
Limited Warranty . . . . .	back cover

## Enjoy your Alto-Shaam Drawer Warmer!

---

**Halo Heat®**

Soft, gentle Halo Heat® – Alto-Shaam Drawer Warmers use the same soft, gentle Halo Heat that made the Alto-Shaam Cook & Hold oven a kitchen staple all over the world. Product moisture is retained without adding water. With no exposed Calrod heating elements, cleaning is easy.

Alto-Shaam Drawer Warmers are available in one-, two- or three drawer configurations and can fit anywhere you need production items held hot and within reach. As one of the most abused pieces of equipment in the kitchen, these units are overbuilt, reflecting the highest level of durability.

## Extend Your Manufacturer's Warranty

---

**Register**

Registering your appliance ensures prompt service in the event of a warranty claim. You will also receive direct notifications of software updates and additional product information.

Your personal information will not be shared with any other company.

[www.alto-shaam.com/warranty](http://www.alto-shaam.com/warranty)

## Alto-Shaam 24/7 Emergency Repair Service

---

**Call**

Call 800-558-8744 to reach our 24-hour emergency service call center for immediate access to local authorized service agencies outside standard business hours. The emergency service access is provided exclusively for Alto-Shaam equipment and is available throughout the United States through Alto-Shaam's toll free number.

**Availability**

Emergency service access is available seven days a week, including holidays.

## Delivery

This Alto-Shaam appliance has been thoroughly tested and inspected to ensure only the highest quality appliance is provided. Upon receipt, check for any possible shipping damage and report it at once to the delivering carrier. See Transportation Damage and Claims section located in this manual.

This appliance, including unattached items and accessories, may be delivered in one or more packages. Ensure all standard items and options have been received with each appliance as ordered. Save all the information packed with the appliance. Register the appliance online at [www.alto-shaam.com/en/support/warranty-registration](http://www.alto-shaam.com/en/support/warranty-registration) to ensure prompt service in the event of a warranty parts and labor claim.

This manual must be read and understood by all people using or installing the appliance. Contact the Alto-Shaam Tech Team Service Department if you have any questions concerning installation, operation, or maintenance.

1-800-558-8744; servicedept@alto-shaam.com

### The serial number is required for all inquiries.

Always include both model and serial number(s) in any correspondence regarding the appliance.

**Model:** \_\_\_\_\_

**Serial number:** \_\_\_\_\_

**Purchased from:** \_\_\_\_\_

**Date installed:** \_\_\_\_\_ **Voltage:** \_\_\_\_\_



## CAUTION



Appliance and accessories may be heavy. To prevent serious injury, **always** use a sufficient number of trained and experienced workers when moving or leveling appliance and handling accessories.

## Environmental Conditions

### Operational Environmental Conditions

- Before use, appliance must acclimate to room temperature in the environment it is placed — 24 hours is recommended.
- Ambient temperature range of 60°F to 110°F (16°C to 43°C).
- Relative humidity of less than 95% non-condensation.
- Atmospheric pressure range of 50kPa to 106kPa.

## Transportation and Damage Claims



All Alto-Shaam equipment is sold Free on Board (F.O.B.) shipping point, and when accepted by the carrier, such shipments become the property of the consignee.

Should damage occur in shipment, do not put the appliance into service until the damage has been inspected by an authorized Alto-Shaam service provider.

Shipping damages are a matter between the carrier and the consignee. In such cases, the carrier is assumed to be responsible for the safe delivery of the merchandise, unless negligence can be established on the part of the shipper.

1. Make an immediate inspection while the appliance is still in the truck or immediately after it is moved to the receiving area. Do not wait until after the appliance is moved to a storage area.
2. Do not sign a delivery receipt or a freight bill until a proper count has been made and inspection of all appliances are received.

3. Note all damage to packages directly on the carrier's delivery receipt.
4. Make certain the driver signs the delivery receipt. If the driver refuses to sign, make a notation of this refusal on the receipt.
5. If the driver refuses to allow inspection, write the following on the delivery receipt: **Driver refuses to allow inspection of containers for visible damage.**
6. Contact the carrier's office immediately upon finding damage, and request an inspection. Mail a written confirmation to the carrier's office with the time, date, and the person called.
7. Save any packages and packing material for further inspection by the carrier.
8. Promptly file a written claim with the carrier and attach copies of all supporting paperwork.

Alto-Shaam will continue our policy of assisting our customers in collecting claims which have been properly filed and actively pursued. Alto-Shaam cannot, however, file any damage claims, assume the responsibility of any claims, or accept deductions in payment for such claims.

Record the model and serial number of the appliance for easy reference. Always refer to both model and serial number in any contact with Alto-Shaam regarding this appliance.

Model: \_\_\_\_\_

Serial Number: \_\_\_\_\_

Date Installed: \_\_\_\_\_

Voltage: \_\_\_\_\_

Purchased From: \_\_\_\_\_

\_\_\_\_\_

\_\_\_\_\_



**Alto-Shaam has established a twenty-four hour emergency service call center to offer immediate customer access to a local authorized service agency outside of standard business hours. The emergency service access is provided exclusively for Alto-Shaam equipment and is available throughout the United States through the use of Alto-Shaam's toll-free number. Emergency service access is available seven days a week including holidays.**

# Unpacking

---

- Carefully remove the appliance from the carton or crate.

**NOTE:** Do not discard the carton and other packaging material until you have inspected the appliance for hidden damage and tested it for proper operation.

Do not discard this manual. This manual is considered to be part of the appliance and is to be provided to the owner or manager of the business or to the person responsible for training operators. Additional manuals are available from the manufacturer.

- Read all instructions in this manual carefully before installing this appliance, using the appliance or performing routine maintenance. Following procedures other than those indicated in this guide to use and clean the appliance is considered inappropriate and may cause damage, injury or fatal accidents, in addition to voiding the warranty and relieving Alto-Shaam of all liability.
- Remove all protective plastic film, packaging materials, and accessories from the appliance before connecting electrical power. Store any accessories in a convenient place for future use.

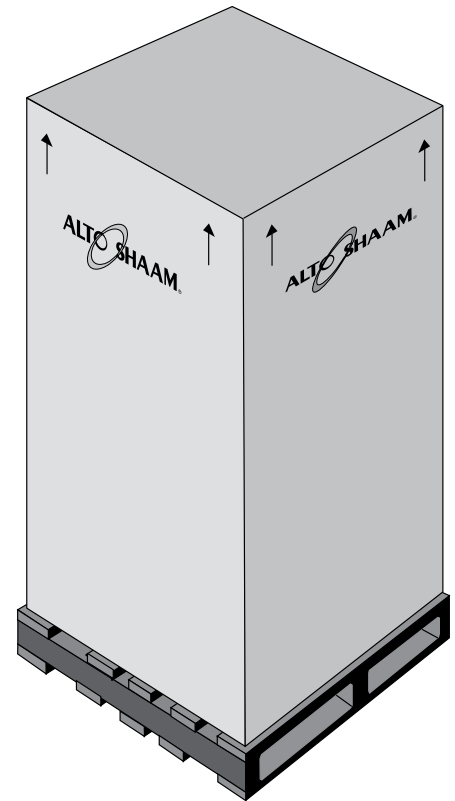

- The appliance is intended to cook, hold or process foods for the purpose of human consumption. No other use for this appliance is authorized and is therefore considered dangerous. The appliance must not be used to cook food containing flammable materials (such as food with alcohol). Substances with a low flash point can ignite spontaneously and cause a fire.
- The appliance is intended for use in commercial establishments where all operators are familiar with the purpose, limitations, and associated hazards of this appliance. Operating instructions and warnings must be read and understood by all operators and users. Alto-Shaam recommends regular staff training to avoid the risk of accident or damage to the appliance. Operators must also receive regular safety instructions.
- Any troubleshooting guides, component views, and parts lists included in this manual are for general reference only and are intended for use by qualified and trained technicians.
- This manual should be considered a permanent part of this appliance. This manual and all supplied instructions, diagrams, schematics, parts lists, notices, and labels must remain with the appliance if the item is sold or moved to another location.

Knowledge of proper procedures is essential to the safe operation of electrically and/or gas energized equipment. The following signal words and symbols may be used throughout this manual.

**⚠ DANGER**  
 Indicates a hazardous situation that, if not avoided, will result in death or serious injury.

**⚠ WARNING**  
 Indicates a hazardous situation that, if not avoided, could result in death or serious injury.

**⚠ CAUTION**  
 Indicates a hazardous situation that, if not avoided, could result in minor or moderate injury.

**NOTICE:** Indicates information considered important, but not hazard-related (e.g., messages relating to property damage).

 Indicates that referral to operating instructions is recommended to understand operation of equipment.

**NOTICE:** For equipment delivered for use in any location regulated by the following directive: 2012/95/EC WEEE



**Do not** dispose of electrical or electronic equipment with other municipal waste.

## Safety Procedures

- To prevent serious injury, death or property damage, the appliance should be inspected and serviced at least every twelve (12) months by an authorized service partner or trained technician.
- **Only** allow an authorized service partner or trained technician to service or to repair the appliance. Installation or repairs that are not performed by an authorized service partner or trained technician, or the use of non-factory authorized parts will void the warranty and relieve Alto-Shaam of all liability.
- When working on this appliance, observe precautions in the literature, on tags, on labels attached to or shipped with the appliance and other safety precautions that may apply.
- If the appliance is installed on casters, freedom of movement of the appliance must be restricted so that utility connections (including gas, water, and electricity) cannot be damaged when the appliance is moved. If the appliance is moved, ensure that all utility connections are properly disconnected. If the appliance is returned to its original position, ensure that retention devices and utility connections are properly connected.
- **Only** use the appliance when it is stationary. Mobile appliance racks, mobile plate racks, transport trolleys, and appliances on casters can tip over when being moved over an uneven floor or threshold and cause serious injury.
- **Always** apply caster brakes on mobile appliances or accessories when these are not being moved. These items could move or roll on uneven floors and cause property damage or serious injury.
- Be extremely careful when moving appliances because the food trays may contain hot fluids that may spill, causing serious injury.
- **Always** open the appliance door very slowly. Escaping hot vapors or steam can cause serious injury.

### **WARNING**



To prevent **serious personal injury, death, or property damage:**

The appliance must be cleaned thoroughly to avoid deposits of grease and or food residue inside the appliance that may catch fire. If fat deposits and/or food waste inside the appliance ignite, shut down the appliance immediately and keep the appliance door closed to extinguish the fire. If further extinguishing is required, disconnect the appliance from the main power and call the fire department. Failure to clean the appliance properly voids the warranty and relieves Alto-Shaam of all liability.

### **WARNING**

This appliance is not intended for use by persons (including children) with reduced physical, sensory or mental capabilities, or lack of experience and knowledge, unless they have been given supervision concerning use of the appliance by person responsible for their safety.

Children should be supervised to ensure that they do not play with the appliance.



**⚠ WARNING**

Improper installation, alteration, adjustment, service, cleaning, or maintenance could result in property damage, severe injury, or death.

Read and understand the installation, operating and maintenance instructions thoroughly before installing, servicing, or operating this equipment.

**⚠ CAUTION**

 To prevent **personal injury** or **property damage**:

**Always** use hand protection when operating this appliance to avoid burns. Metal parts of this equipment become extremely hot when in operation.

**⚠ CAUTION**

 Appliance and accessories may be heavy. To prevent serious injury, **always** use a sufficient number of trained and experienced workers when moving or leveling appliance and handling accessories.

**⚠ WARNING**

 To prevent personal injury, death or property damage:

**Do not** store or use gasoline or other flammable vapors or liquids in the vicinity of this or any other appliance.

This Alto-Shaam appliance must be installed in a location that will permit it to function for its intended purpose and to allow adequate clearance for ventilation, proper cleaning, and maintenance access.

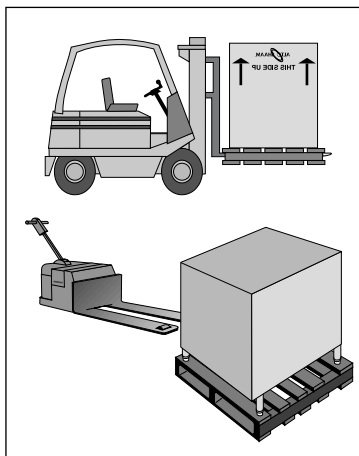

1. This appliance must be installed on a stable and level surface.
2. Do not install this appliance in any area where it may be affected by any adverse conditions such as steam, grease, dripping water, high temperatures, or any other severely adverse conditions.
3. This appliance must be kept free and clear of any obstructions blocking access for maintenance or service.

Minimum Clearance Requirements	
<b>Back</b>	3" (76mm)
<b>Top</b>	2" (51mm)
<b>Left side, Right side</b>	1" (25mm)

Weight (est.)			
	<b>500-1D</b>	<b>500-2D</b>	<b>500-3D</b>
<b>Net</b>	80 lb (36 kg)	115 lb (52 kg)	150 lb (68 kg)
<b>Ship</b>	90 lb (41 kg)	125 lb (57 kg)	165 lb (75 kg)
	<b>500-1DN</b>	<b>500-2DN</b>	<b>500-3DN</b>
<b>Net</b>	67 lb (30 kg)	100 lb (45 kg)	130 lb (59 kg)
<b>Ship</b>	75 lb (34 kg)	112 lb (51 kg)	145 lb (66 kg)

Product Capacity (each drawer)	
Full-Size Pan (GN1/1) - 12" x 20" x 6" (305 x 508 x 152mm)	36 lbs (16 kg) Maximum
Oversize Pan - 15" x 20" x 5" (381 x 508 x 127mm)	41 lbs (19 kg) maximum

# Installation

## 500-1D, 500-2D, 500-3D

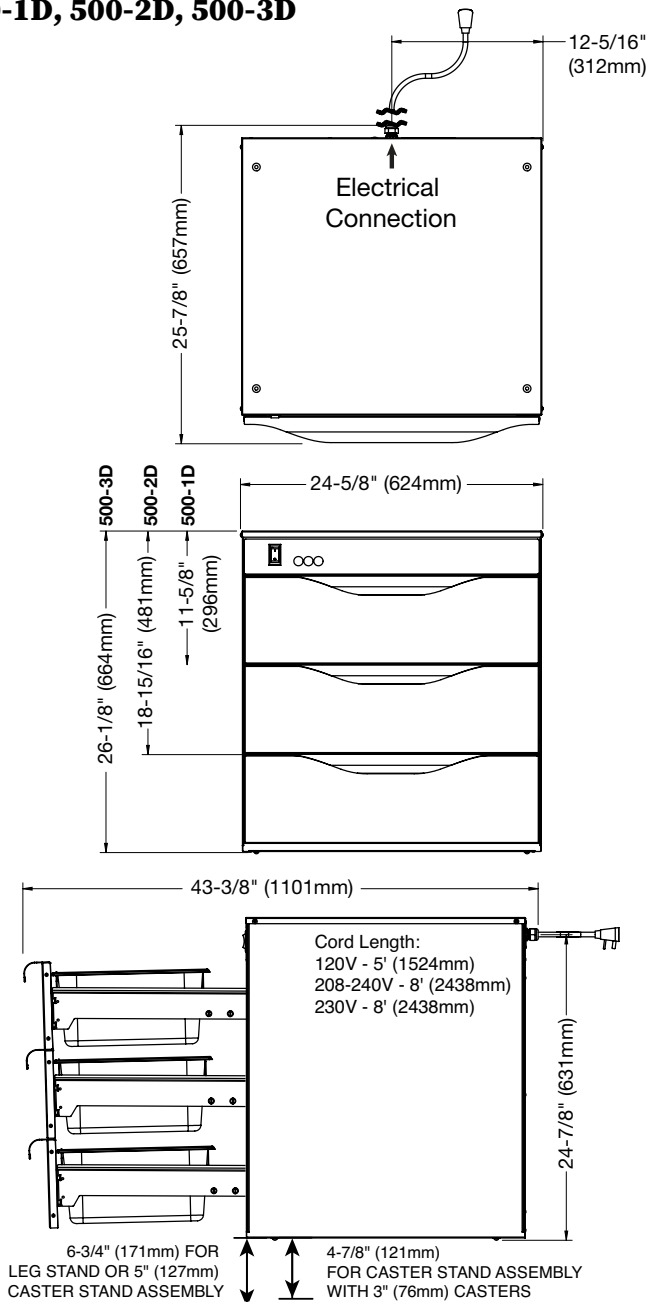

## 500-2DI

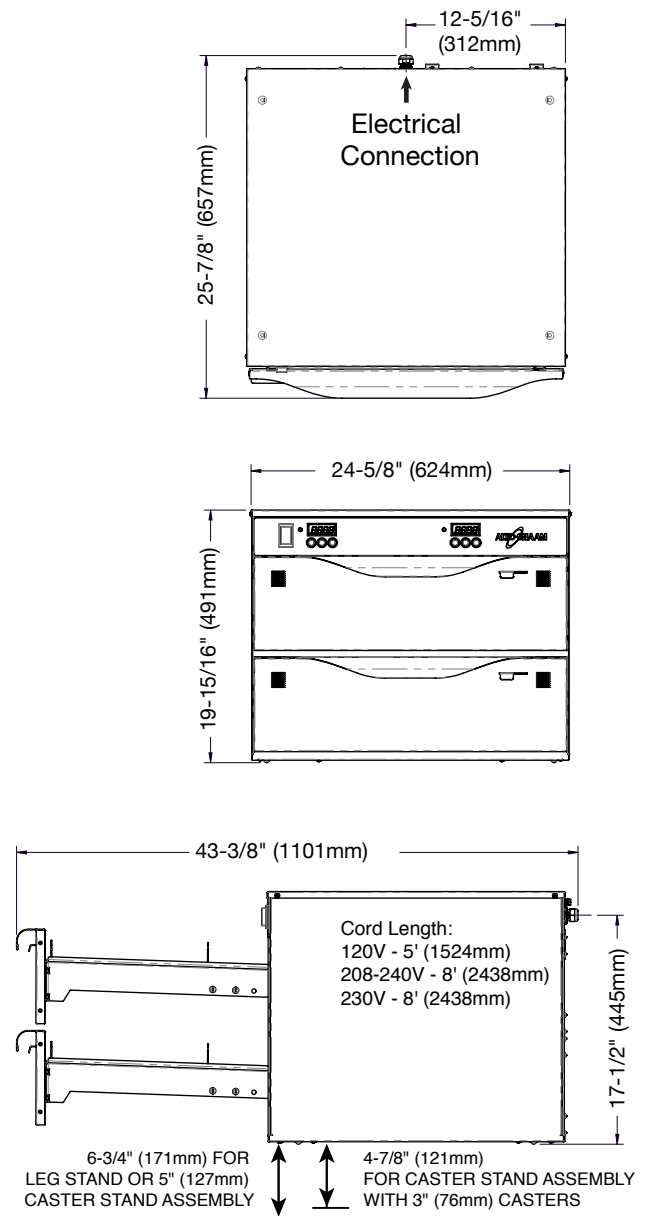

### Cutout Dimensions (for units with built in trim)

Add 3/4" (19mm) to unit height and 1-1/2" (38mm) to unit width

Accessories			
Built-in Trim Kit		Leg Stand Assembly	15380
500-1D	5015147	Pan	
500-2D	5015149	Oversize, 15" x 20" x 5" (381 x 508 x 127mm)	PN-2123
500-3D	5005153	Full-size, 12 x 20 x 6 (305 x 508 x 152mm)	PN-25088
Caster Stand Assembly		Perforated pan grid	
- with 5" (127mm) casters	15379	15" x 20" (381mm x 508mm)	1231
- with 3" (76mm) casters	5010920	12" x 20" (305mm x 508mm)	16642

**500-1DN, 500-2DN, 500-3DN**

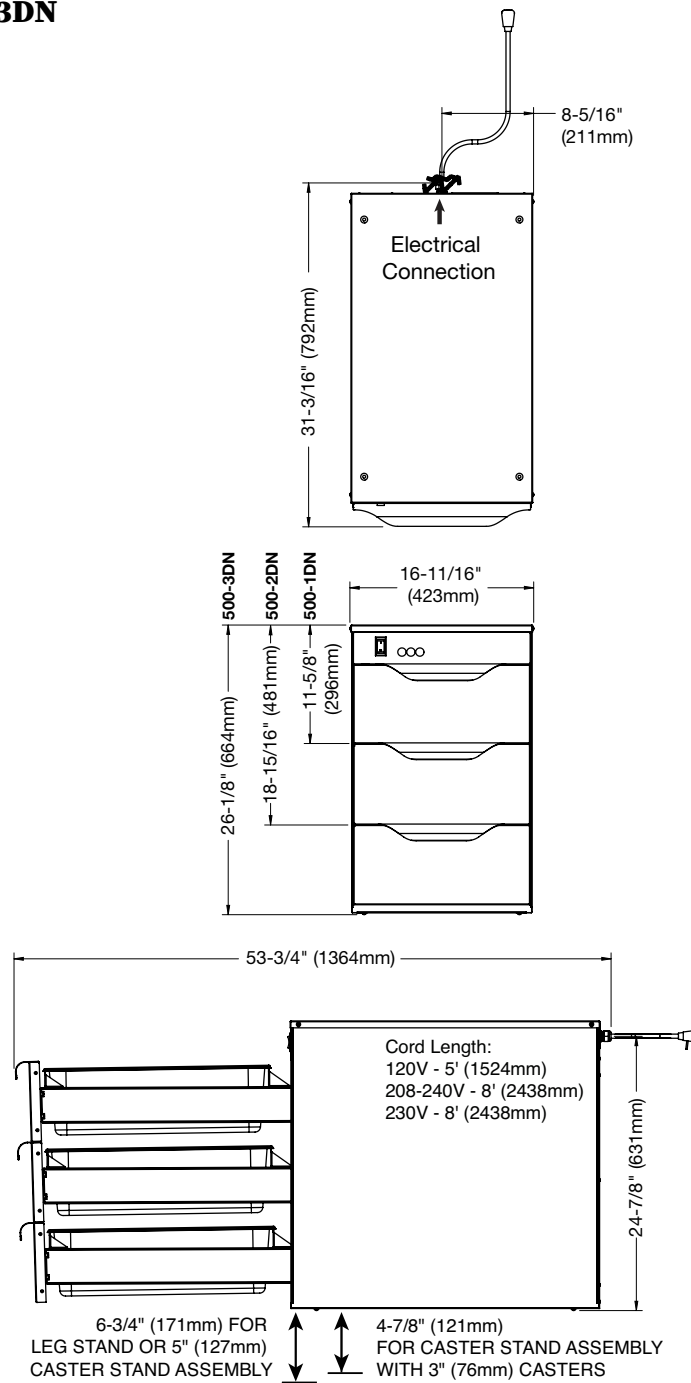

**Cutout Dimensions** (for units with built in trim)  
 Add 3/4" (19mm) to unit height and 1-1/2" (38mm) to unit width

<b>Accessories</b>			
<b>Built-in Trim Kit</b>		<b>Caster Stand Assembly</b>	
500-1DN	5015148	- with 5" (127mm) casters	55534
500-2DN	5015150	- with 3" (76mm) casters	5010921
500-3DN	5015154	<b>Leg Stand Assembly</b>	55535
		Perforated pan grid, 12" x 20" (305mm x 508mm)	16642

# Electrical Connection

1. An identification tag is permanently mounted on the Drawer Warmer.
2. Plug Drawer Warmer into a properly grounded receptacle only, positioning the unit so the power supply cord is easily accessible in case of an emergency.







Arcing will occur when connecting or disconnecting the unit unless all controls are in the “Off” position.







3. If necessary, a proper receptacle or outlet configuration as required for this unit, must be installed by a licensed electrician in accordance with applicable, local electrical codes.

## Hard wired models

Hard wired models must be equipped with a country certified external allpole disconnection switch with sufficient contact separation. Hard wired models that are mounted on casters must have a strain relief device (tether) to prevent strain on the power supply cord. If a power cord is used for the connection of the product an oil resistant cord like H05RN or H07RN or equivalent must be used.

**NOTICE:** Where local codes and CE regulatory requirements apply, appliances must be connected to an electrical circuit that is protected by an external GFCI outlet.

Electrical - 500-1D, 1DN, 2D, 2DN, 3D, 3DN							
V	Ph	Hz	A	kW			
120	1	50/60	5.3	0.64		NEMA 5-15P 15A, 125V plug	
208-240	1	50/60	2.7	0.64		NEMA 6-15P 15A, 250V plug	
230	1	50/60	2.6	0.59	Plugs rated 250V, IPX4		
	CEE 7/7		CH2-16P		BS 1363		AS/NZS 3112

Electrical - 500-2DI							
V	Ph	Hz	A	kW			
120	1	60	10.7	1.28		NEMA 5-15P 15A, 125V plug	
208-240	1	60	5.3	9.6-1.28		NEMA 6-15P 15A, 250V plug	
230	1	50/60	5.1	1.18	Plugs rated 250V, IPX4		
	CEE 7/7		CH2-16P		BS 1363		AS/NZS 3112



This section is provided for the assistance of qualified and trained service technicians only and is not intended for use by untrained or unauthorized service personnel. Failure to observe this precaution may void the warranty.

**⚠ WARNING**

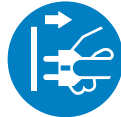

To prevent serious injury, death, or property damage, **always** disconnect the appliance from the power source before cleaning or servicing.

**⚠ WARNING**



To prevent serious injury, death, or property damage:

All electrical connections must be made by a qualified and trained service technician in accordance with applicable electrical codes.



This appliance must be adequately grounded in accordance with local electrical codes or, in the absence of local codes, with the current edition of the National Electrical Code ANSI/NFPA No. 70. In Canada, all electrical connections are to be made in accordance with CSA C22.1, Canadian Electrical Code Part 1 or local codes.



CE-approved appliances include an equipotential-bonding terminal marked with the symbol shown on the left. Provisions for earthing are to be made in accordance with IEC:2010 60335-1 section 27 or local codes.

Wire diagrams are located inside the bonnet of the unit.

**Before initial use:**

Clean both the interior and exterior of the unit with a clean, damp cloth and mild soap solution. Rinse carefully. Clean and install the drawer warmer pan(s). The drawer assembly is completely removable.

**Heating Characteristics**

The drawer warmer is equipped with a special heating element. Through this Halo Heat concept, the heating element is mounted against the walls of the unit to provide an evenly applied heat source controlled by a digital control. The design and operational characteristics of the unit eliminate the need for a moisture pan or a heat circulating fan. Through even heat application, the quality of food products is maintained up to several hours or more.

**Food Product Tips****Bread and Rolls**

Breads and rolls are traditionally difficult to hold for prolonged periods due to the very low moisture content of these products. For best results and longest possible holding life, it is recommended these products be placed in a plastic bag while in the warming drawer. Breads and rolls should be held at a temperature no higher than 120° to 140°F (49° to 60°C).

**Potatoes**

For the best results when holding potatoes:

**1. Do not overcook.**

Regardless of the temperature at which potatoes are cooked or what type of oven is used, it is important that this product does not achieve a final internal product temperature in excess of 195°F (91°C). Over-cooking will further reduce the moisture content and consequently, reduce the holding life. Potatoes should be removed from the oven when they reach an internal temperature of approximately 190°F (88°C). After they are removed from the oven, the internal temperature will continue to increase.

**2. Allow potatoes to stabilize before placing in drawer warmer.**

When potatoes are removed from a conventional high-temperature oven, they have an extremely high surface temperature. If they are placed in the drawer warmer while they are this hot on the outside, moisture will be pulled from the inside of the potato and condensation will form on the outside. Holding results under these conditions will not be totally satisfactory. Remove potatoes from the oven and allow the surface temperature to stabilize before placing them in the controlled holding atmosphere of the drawer warmer.

# Operation

## 1. Preheat Drawer Warmer at 200°F (93°C) for 30 minutes before loading hot food.

Push power switch to the On position. The unit will begin operating at the previous set temperature.

- Press the **Up Arrow** or **Down Arrow** to 200°F (93°C). Pressing and releasing the **Up Arrow** or **Down Arrow** will change the set point by 1 degree. Pressing and holding the **Up Arrow** or **Down Arrow** will change set point by 10 degrees. When Arrow is released, a new set point temperature is set. The set temperature will appear in the **Digital Display** and the **Heat Indicator Light** will illuminate. Press the **Temperature Display** button for three seconds at any time to display the actual inside air temperature.

### To toggle between set temperature and actual inside air temperature:

Factory default is to display set temperature in the **Digital Display**. To display actual temperature:

Press and hold the **Temperature Display** button and the **Up Arrow** for 5 seconds. The control will show **ACT** then show the actual temperature.

Repeat to toggle to display Set temperature **SET**.

Press the **Temperature Display** button at any time to display the alternate temperature.

- When the inside air temperature reaches the desired holding temperature, the **Heat Indicator Light** will turn off.

## 4. Load the Drawer Warmer with hot food only.

The purpose of the drawer warmer is to maintain hot food at proper serving temperatures. Only hot food should be placed in the Drawer Warmer. Before loading the Drawer Warmer with food, use a food thermometer to ensure all food products are at an internal temperature range of 140°F to 160°F (60°C to 71°C). All food not within the proper temperature range must be heated to the proper temperature before loading into the Drawer Warmer.

- Check to ensure the drawers are securely closed, and use the **Up Arrow** or **Down Arrow** to set the temperature to 160°F (71°C).

### This will not necessarily be the final setting.

The proper temperature range for the food being held will depend on the type and quantity of product. Whether or not the optional drawer vents should be open or closed will also depend on the type of food being held. When holding food for prolonged periods, it is advisable to periodically check the internal temperature of each item to ensure maintenance of the proper temperature range. Reset the holding temperature accordingly.

### To toggle between Fahrenheit and Celsius:

The factory default is Fahrenheit. To change to Celsius:

- Press and hold the **Temperature Display** button and the **Down Arrow** for 5 seconds.
- The control will show **°C** for 3 seconds to verify selection and then show the temperature. (Set temperature or actual temperature, whichever the user has selected) in °C.
- Repeat to toggle to Fahrenheit.

Press the **Temperature Display** button at any time to display the alternate temperature.

**NOTICE:** In the event of a power failure, the control will retain the °C or °F setting selected by the user.

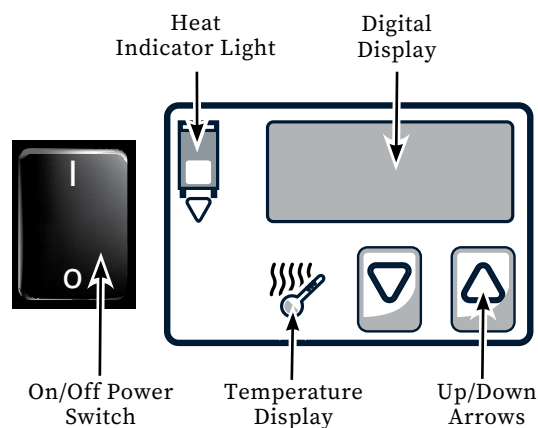

## General Holding Guidelines

Chefs, cooks and other specialized food service personnel employ varied methods of cooking. Proper holding temperatures for a specific food product must be based on the moisture content of the product, product density, volume, and proper serving temperatures. Safe holding temperatures must also be correlated with palatability in determining the length of holding time for a specific product.

Halo Heat maintains the maximum amount of product moisture content without the addition of water, water vapor, or steam. Maintaining maximum natural product moisture preserves the natural flavor of the product and provides a more genuine taste. In addition to product moisture retention, the gentle properties of Halo Heat maintain a consistent temperature throughout the cabinet without the necessity of a heat distribution fan, thereby preventing further moisture loss due to evaporation or dehydration.

In an enclosed holding environment, too much moisture content is a condition which can be relieved. A product achieving extremely high temperatures in preparation must be allowed to decrease in temperature before being placed in a controlled holding atmosphere. If the product is not allowed to decrease in temperature, excessive condensation will form increasing the moisture content on the outside of the product. To preserve the safety and quality of freshly cooked foods however, a maximum of 1 to 2 minutes must be the only time period allowed for the initial heat to be released from the product.

Most Halo Heat holding equipment is provided with a thermostat control between 60°F and 200°F (16°C to 93°C). If the unit is equipped with vents, close the vents for moist holding and open the vents for crisp holding.

Holding Temperature Range		
Meat	Fahrenheit	Celsius
Beef Roast — Rare	130°F	54°C
Beef Roast — Med/Well Done	155°F	68°C
Beef Brisket	160°F-175°F	71°C-79°C
Corn Beef	160°F-175°F	71°C-79°C
Pastrami	160°F-175°F	71°C-79°C
Prime Rib — Rare	130°F	54°C
Steaks — Broiled/Fried	140°F-160°F	60°C-71°C
Ribs — Beef Or Pork	160°F	71°C
Veal	160°F-175°F	71°C-79°C
Ham	160°F-175°F	71°C-79°C
Pork	160°F-175°F	71°C-79°C
Lamb	160°F-175°F	71°C-79°C
Poultry		
Chicken — Fried/Baked	160°F-175°F	71°C-79°C
Duck	160°F-175°F	71°C-79°C
Turkey	160°F-175°F	71°C-79°C
General	160°F-175°F	71°C-79°C
Fish/Seafood		
Fish — Baked/Fried	160°F-175°F	71°C-79°C
Lobster	160°F-175°F	71°C-79°C
Shrimp — Fried	160°F-175°F	71°C-79°C
Baked Goods		
Breads/Rolls	120°F-140°F	49°C-60°C
Miscellaneous		
Casseroles	160°F-175°F	71°C-79°C
Dough — Proofing	80°F-100°F	27°C-38°C
Eggs — Fried	150°F-160°F	66°C-71°C
Frozen Entrees	160°F-175°F	71°C-79°C
Hors d'oeuvres	160°F-180°F	71°C-82°C
Pasta	160°F-180°F	71°C-82°C
Pizza	160°F-180°F	71°C-82°C
Potatoes	180°F	82°C
Plated Meals	140°F-165°F	60°C-74°C
Sauces	140°F-200°F	60°C-93°C
Soup	140°F-200°F	60°C-93°C
Vegetables	160°F-175°F	71°C-79°C
The holding temperatures listed are suggested guidelines only. All food holding should be based on internal product temperatures. Always follow local health (hygiene) regulations for all internal temperature requirements.		

# Cleaning and Preventative Maintenance

## Protecting Stainless Steel Surfaces



It is important to guard against corrosion in the care of stainless steel surfaces. Harsh, corrosive, or inappropriate chemicals can completely destroy the protective surface layer of stainless steel. Abrasive pads, steel wool, or metal implements will abrade surfaces causing damage to this protective coating and will eventually result in areas of corrosion. Even water, particularly hard water that contains high to moderate concentrations of chloride, will cause oxidation and pitting that result in rust and corrosion. In addition, many acidic foods spilled and left to remain on metal surfaces are contributing factors that will corrode surfaces.

Proper cleaning agents, materials, and methods are vital to maintaining the appearance and life of this appliance. Spilled foods should be removed and the area wiped as soon as possible but at the very least, a minimum of once per day. Always thoroughly rinse surfaces after using a cleaning agent and wipe standing water as quickly as possible after rinsing.

## Cleaning Agents

Use non-abrasive cleaning products designed for use on stainless steel surfaces. Cleaning agents must be chloride-free compounds and must not contain quaternary salts. Never use hydrochloric acid (muriatic acid) on stainless steel surfaces. Failure to observe this precaution will void the warranty. Always use the proper cleaning agent at the manufacturer's recommended strength. Contact your local cleaning supplier for product recommendations.

## Cleaning Materials

Cleaning can usually be accomplished with the proper cleaning agent and a soft, clean cloth. When more aggressive methods are needed, use a non-abrasive scouring pad on difficult areas and make certain to scrub with the visible grain of surface metal to avoid surface scratches. Never use wire brushes, metal scouring pads, or scrapers to remove food residue. Failure to observe this precaution will void the warranty.

### NOTICE



To protect stainless steel surfaces, completely avoid the use of abrasive cleaning compounds, chloride based cleaners, or cleaners containing quaternary salts. **Never** use hydrochloric acid (muriatic acid) on stainless steel. **Never** use wire brushes, metal scouring pads or scrapers.

### ! WARNING



To prevent **serious personal injury, death, or property damage:**

The appliance must be cleaned thoroughly to avoid deposits of grease and or food residue inside the appliance that may catch fire. If fat deposits and/or food waste inside the appliance ignite, shut down the appliance immediately and keep the appliance door closed to extinguish the fire. If further extinguishing is required, disconnect the appliance from the main power and call the fire department. Failure to clean the appliance properly voids the warranty and relieves Alto-Shaam of all liability.



## Cleaning and Preventative Maintenance

### **WARNING**



To prevent serious personal injury, death, or property damage:

**Do not** steam clean, hose down or flood the interior or exterior with water or liquid solution of any kind. **Do not** use water jet to clean. Failure to observe this precaution will void the warranty.

### **WARNING**

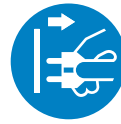

To prevent serious injury, death, or property damage, **always** disconnect the appliance from the power source before cleaning or servicing.

### Clean the Drawer Warmer Daily

1. Disconnect unit from power source and let cool.
2. Remove drawer pans and clean separately. Remove the drawers. Remove the drawer rails by lifting the rail off of the bottom pins and bolt, and then sliding it off of the top pin.
3. Clean the interior metal surfaces of the warmer with a damp clean cloth or sponge and any good commercial detergent.
 

**NOTICE:** Never use abrasive cleaning compounds, chloride-based cleaners, or cleaners containing quaternary salts. Never use hydrochloric acid (muriatic acid) on stainless steel.
4. Spray heavily soiled areas with a water soluble degreaser and let stand for 10 minutes, then remove soil with a plastic scouring pad.
5. Wipe control panel, drawer vents, handles, and gaskets thoroughly since these areas harbor food debris.
6. Rinse surfaces by wiping with sponge and clean warm water.
7. Remove excess water with sponge and wipe dry with a clean cloth or air dry. Leave drawers open until interior is completely dry.
8. Wipe door gaskets and control panel dry with a clean, soft cloth.
9. Wipe interior with a sanitizing solution after cleaning and rinsing. This solution must be approved for use on stainless steel food contact surfaces.
10. To help maintain the protective film coating on polished stainless steel, clean the exterior of the Drawer Warmer with a cleaner recommended for stainless steel surfaces. Spray the cleaning agent on a clean cloth and wipe with the grain of the stainless steel.

Always follow appropriate state or local health (hygiene) regulations regarding all applicable cleaning and sanitation requirements for equipment.

## Food Safety

Food flavor and aroma are usually so closely related that it is difficult, if not impossible, to separate them. There is also an important, inseparable relationship between cleanliness and food flavor. Cleanliness, operating efficiency, and appearance of equipment contribute considerably to savory, appetizing foods.

Most food imparts its own particular aroma and many foods also absorb existing odors. Unfortunately, during this absorption there is not a distinction between **good** and **bad** odors. The majority of objectionable flavors and odors troubling food service operations are caused by bacteria growth. Sourness, rancidity, mustiness, stale or other undesirable flavors are usually the result of germ activity.

The easiest way to ensure full, natural food flavor is through comprehensive cleanliness. This means good control of both visible soil (dirt) and invisible soil (germs). A thorough approach to sanitation will provide essential cleanliness. It will ensure an attractive appearance of equipment, along with maximum efficiency and utility. More importantly, a good sanitation program provides one of the key elements in the prevention of food-borne illnesses.

A comprehensive sanitation program should focus on the training of staff in basic sanitation procedures. This includes personal hygiene, proper handling of raw foods, cooking to a safe internal product temperature, and the routine monitoring of internal food temperatures from the time the food is received through the time the food is served.

A controlled holding environment for prepared foods is just one of the important factors involved in the prevention of food-borne illnesses. Temperature monitoring and control during receiving, storage, preparation, and the service of foods are of equal importance.

The most accurate method of measuring safe temperatures of both hot and cold foods is by internal product temperature. A thermometer is an effective tool for this purpose, and should be routinely used on all products that require holding at a specific temperature.

Internal Food Product Temperatures		
<b>Hot Foods</b>		
Danger Zone	40°F to 140°F	4°C to 60°C
Critical Zone	70°F to 120°F	21°C to 49°C
Safe Zone	140°F to 165°F	60°C to 74°C
<b>Cold Foods</b>		
Danger Zone	Above 40°F	Above 4°C
Safe Zone	36°F to 40°F	2°C to 4°C
<b>Frozen Foods</b>		
Danger Zone	Above 32°F	Above 0°C
Critical Zone	0°F to 32°F	-18°C to 0°C
Safe Zone	0°F or Below	-18°C or Below

Hazard Analysis (at) Critical Control Points (HACCP), is a quality control program of operating procedures to assure food integrity, quality, and safety. Taking steps necessary to augment food safety practices is both cost effective and relatively simple. Additional HACCP information is available by contacting:

Center for Food Safety and Applied Nutrition  
 Food and Drug Administration  
 Phone: 1-888-SAFEFOOD  
[www.foodsafety.gov](http://www.foodsafety.gov)

## Thermostat Calibration

If you suspect the temperature inside the holding compartment does not match the temperature indicated on the digital display, follow the instructions listed below.

1. Ensure the unit voltage matches the power source.
2. Verify the temperature inside the holding compartment with a quality thermal indicator.
  - a. With the exception of the wire shelves, completely empty the holding compartment.
  - b. Ensure the drawer warmer sensor, located inside the drawer is completely clean.
  - c. Suspend the thermal indicator in the center of the drawer.
  - d. Allow the temperature set on the electronic thermostat to stabilize for a minimum of one hour before comparing the digital display with the reading on the thermal indicator.

### Do not open the drawer warmer drawer(s) during the temperature stabilization period.

If the reading on the thermal indicator does not match the digital display, there may be a problem with the air sensor. See troubleshooting guide in this manual; or call the Alto-Shaam Service Department for advice.

## How to verify sensor integrity

Place the sensor in ice water. Test with an ohmmeter set to the ohm scale.

Air sensor	1000 ohms $\pm$ 20
------------	--------------------

If the reading is more than  $\pm$  20 ohms, replace sensor.



This section is provided for the assistance of qualified technicians only and is not intended for use by untrained or unauthorized service personnel. If your Alto-Shaam® unit is not operating properly, check the following before calling your Authorized Alto-Shaam Service Agent:

- \* Check main power circuit breaker to the unit and verify that the circuit breaker on the back of the unit is turned on, if applicable.

Do not attempt to repair or service the unit beyond this point. **Contact Alto-Shaam for the nearest authorized service agent. Repairs made by any other service agents without prior authorization by Alto-Shaam® will void the warranty on the unit.**

## WARNING

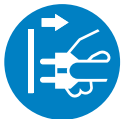

To prevent serious injury, death, or property damage, **always** disconnect the appliance from the power source before cleaning or servicing.



This section is provided for the assistance of qualified and trained service technicians only and is not intended for use by untrained or unauthorized service personnel. Failure to observe this precaution may void the warranty.

# Troubleshooting

Code	Description	Possible Causes
E-10	<b>Cavity air sensor shorted</b>	Cavity air sensor reading < 5°F (-15°C). Verify sensor integrity.
E-11	<b>Cavity air sensor open</b>	Cavity air sensor reading > 517°F (269°C). Verify sensor integrity.
E-20	<b>Product probe is shorted</b> <i>Oven will cook in time only</i>	Product probe reading < 5°F (-15°C). Verify sensor integrity.
E-21	<b>Product probe is open</b> <i>Oven will cook in time only</i>	Product Probe reading > 517°F (269°C). Verify sensor integrity.
E-30	<b>Under temperature</b>	Unit has been more than 25°F (14°C) below set point for longer than 90 minutes.
E-31	<b>Over temperature</b>	Unit has been more than 60°F (33°C) above the maximum set-point for longer than 3 minutes. Holding Cabinets with this error code are more than 145°F (81°C) above the maximum set-point.
E-32	<b>Safety switch open (Aux hi-limit switch)</b>	Contact factory.
E-38	<b>Internal software error</b>	Contact factory.
E-39	<b>Sensor error</b>	Contact factory.
E-50	<b>Temp. measurement error</b>	Contact factory.
E-51	<b>Temp. measurement error</b>	Contact factory.
E-60	<b>Real time clock error</b>	Data set to factory default. Ensure that date and time are correct if applicable.
E-61	<b>Real time clock error</b>	Contact factory.
E-64	<b>Clock is not oscillating</b>	Contact factory.
E-70	<b>Configuration connector error (DIP switch)</b>	Refer to wiring diagram for the particular model and ensure dip switches on the control match the settings called out on the WD. If the dip switch settings are correct according to the print replace the control.
E-78	<b>Voltage low</b>	Voltage below 90 VAC on a 125 VAC unit, or below 190 VAC on a 208-240 VAC unit. Correct voltage.
E-79	<b>Voltage high</b>	Voltage over 135 VAC on a 125 VAC unit, or over 250 VAC on a 208-240 VAC unit. Correct voltage.
E-80	<b>EEPROM Error</b>	Ensure that all temperatures and times are properly set. Contact factory if problem persists.
E-81	<b>EEPROM Error</b>	Contact factory.
E-82	<b>EEPROM Error</b>	Contact factory.
E-83	<b>EEPROM Error</b>	Contact factory.
E-85	<b>EEPROM Error</b>	All timers, if previously on, are now off. Possible bad EEPROM.
E-86	<b>EEPROM Error</b>	Stored HACCP memory corrupted. HACCP Address reset to 1. Possible bad EEPROM. Contact factory if problem persists.
E-87	<b>EEPROM Error</b>	Stored offsets corrupted. Offsets reset to 0. Control may need a recalibration. Possible bad EEPROM. Contact factory if problem persists.
E-88	<b>EEPROM Error</b>	All timer set-points are reset to 1 minute. Timers, if previously on, are now off. Possible bad EEPROM.
E-90	<b>Button stuck</b>	A button has been held down for > 60 seconds. Adjust control. Error will reset when the problem has been resolved.
E-91	<b>Input failure</b>	Contact factory.
E-dS	<b>Datakey error</b>	Datakey digital signature incompatible. Cycle power, and install compatible Datakey if error persists.
E-dT	<b>Datakey error</b>	Datakey incompatible with control. Install compatible Datakey.
E-dU	<b>Datakey unplugged</b>	Install Datakey and cycle power to control to clear error.
dLto	<b>Datalogger has timed out</b>	Cycle power. Contact factory if error persists.
dLSD	<b>Micro SD card not plugged in</b>	Plug in SD card and cycle power. Contact factory if error persists.
<b>NOTE:</b> If in doubt, always cycle the power to the control and contact factory if the problem persists.		

500-D Exterior

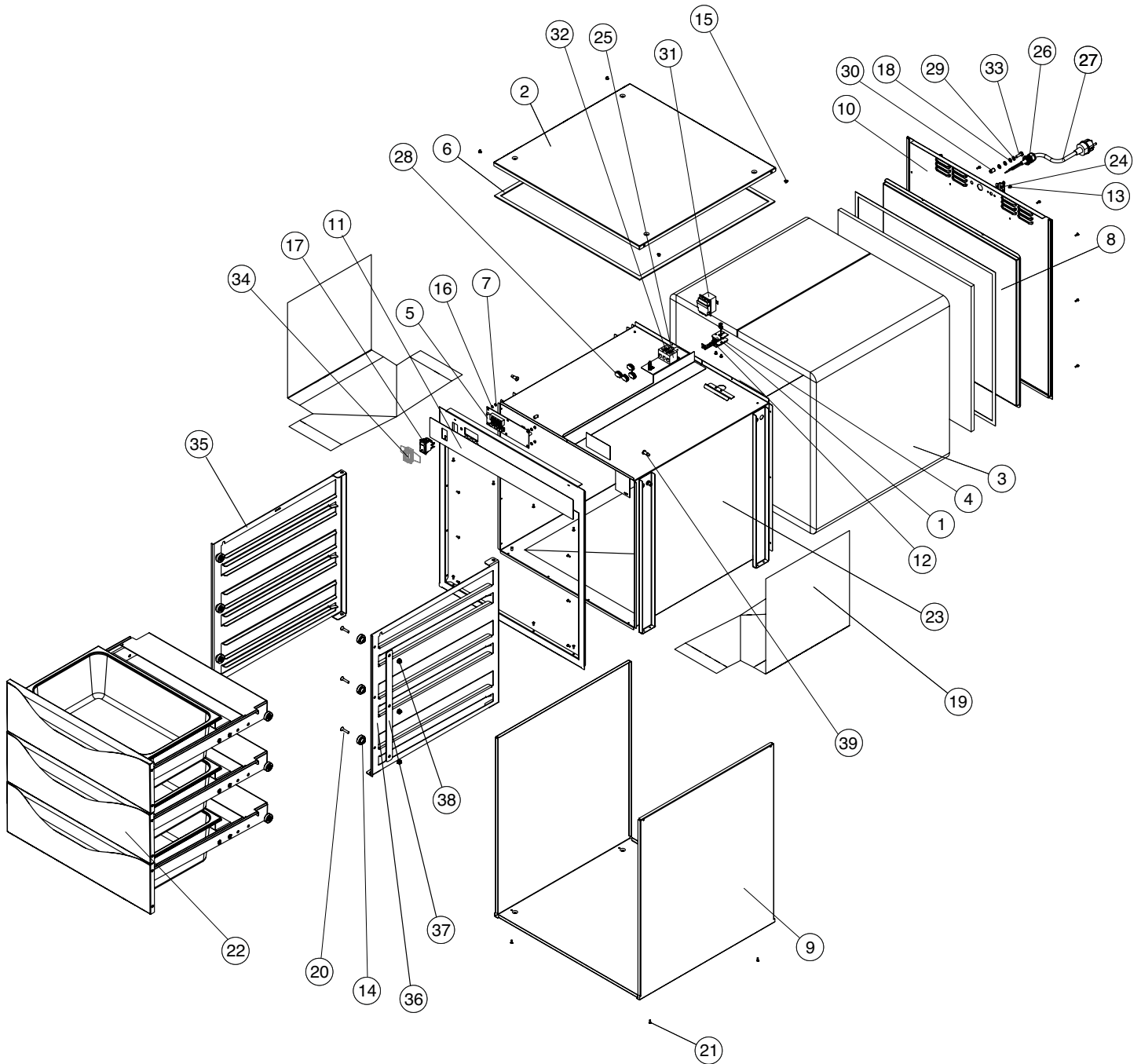

Part numbers and drawings are subject to change without notice.

For builds prior to August 1, 2018, please consult the Alto-Shaam website ([alto-shaam.com](http://alto-shaam.com))

# Service

## 500-D Exterior Parts List

Item	Part	Description	Qty
1	1493	BRACKET, SENSOR MTG.	1
2	1012473	TOP COVER	1
3	IN-2003	INSULATION, FIBERGLASS, #3 DENS 1/2"	1
4	BK-29605	CONTROL SENSOR BLOCK	1
5	CC-34970	WARMER CONTROL	1
6	GS-23622	GASKET, WITH ADHESIVE 0.125 x 0.375 [lin ft]	1
7	NU-2361	NUT, 6-32 HEX, S/S	4
8	1026878	INNER BACK PANEL, 500-3D	1
	1026722	INNER BACK PANEL, 500-2D	1
	1012667	INNER BACK PANEL, 500-1D	1
9	1027230	OUTER CASING, 500-3D	1
	1027231	OUTER CASING, 500-2D	1
	1012664	OUTER CASING, 500-1D	1
10	1012446	REAR TRIM, 500-3D	1
	1012674	REAR TRIM, 500-2D	1
	1012665	REAR TRIM, 500-1D	1
11	PE-29685	PANEL OVERLAY	1
12	SN-38111	SENSOR	1
13	SC-22271	SCREW, M4-0.7 x 6mm PHIL	4
14	BG-24890	BEARING, DRAWER WARMER	6
15	SC-2459	SCREW, 8-32 x 1/4" PHIL SCREW	4
16	WS-23148	WASHER, 6-32, FLAT, NYLON	4
17	SW-34769	SWITCH, ROCKER, 125-277V, 20A	1
18	WS-22302	WASHER, SPLIT LOCK	1
19	EL-29875	ELEMENT, 320W, FOIL PAD HEATER	2
20	SC-25018	SCREW, 1/4-20 x 1-1/8" FLAT HD	6
21	RI-38125	RIVET, SEALED, .125", SST, DOME HD	30
22	5013915R	DRAWER FRAME ASSEMBLY	1
	5014559R	VENTED DRAWER FRAME ASSEMBLY	1
	5017070R	DRAWER FRAME ASSEMBLY, OVERSIZE PAN	1
	5017071R	VENTED DRAWER FRAME ASSEMBLY, OVERSIZE PAN	1
23	5026538	TUBE SPOT ASSEMBLY, 500-3D	1
	5026539	TUBE SPOT ASSEMBLY, 500-2D	1
	5014252	TUBE SPOT ASSEMBLY, 500-1D	1
24	1003936	HI-LIMIT PROTECTION COVER	1
25	BK-3019	T-BLOCK	1
26	BU-3964	BUSHING, STRAIGHT, STRAIN RELIEF	1
27	CD-3922	CORDSET-16AWG, 3/C, INT'L HARM	1
28	CR-34967	CONNECTOR-2 CONDUCTOR	2
29	WS-22297	WASHER, FLAT	2
30	NU-22770	NUT, THREADED INSERT, M6	1
31	TT-33476	THERMOSTAT, 300°F HI-LIMIT	1
32	SC-2365	SCREW, 6-32 x 1-1/4" ROUND HD	2
33	SC-22924	SCREW, HHCS, M6 x 20, W/NO MARKING	1
34	CV-38297	SWITCH COVER (230V ONLY)	1
35	5026326R	RAIL SERVICE KIT, LEFT, 500-3D	1
	5026289R	RAIL, SERVICE KIT, LEFT, 500-2D	1
36	5026330R	RAIL, SERVICE KIT, RIGHT, 500-3D	1
	5026295R	RAIL, SERVICE KIT, RIGHT, 500-2D	1
37	1026880	STIFFENER, RAIL ASSEMBLY, 500-3D	2
	1026774	STIFFENER, RAIL ASSEMBLY, 500-2D	2
38	NU-29475	NUT, 1/4-20, KEPS, S/S	4
39	SC-39699	SCREW, SOCKET, SHOULDER 1/4-20"	2

\* not shown

## Rail Service Kits - 500-2D, 500-3D

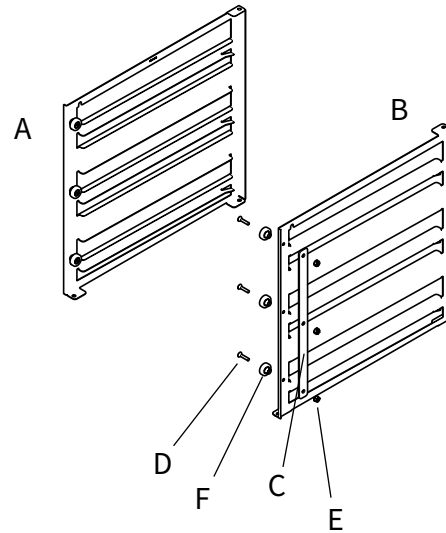

5026289R - 500-2D - Left hand rail assembly kit			
Item	Part	Description	Qty
A	1026728	Rail, left hand	1
C	1026774	Stiffener	1
D	SC-25018	Screw, 1/4-20 x 1-1/8" Flat Hd	2
E	NU-29475	Nut, 1/4-20 KEPS, S/S	2
F	BG-24890	Bearing	2
5026295R - 500-2D - Right hand rail assembly kit			
B	1026783	Rail, right hand	1
C	1026774	Stiffener	1
D	SC-25018	Screw, 1/4-20 x 1-1/8" Flat Hd	2
E	NU-29475	Nut, 1/4-20 KEPS, S/S	2
F	BG-24890	Bearing	2
5026326R - 500-3D - Left hand rail assembly kit			
A	1026879	Rail, left hand	1
C	1026880	Stiffener	1
D	SC-25018	Screw, 1/4-20 x 1-1/8" Flat Hd	3
E	NU-29475	Nut, 1/4-20 KEPS, S/S	3
F	BG-24890	Bearing	3
5026330R - 500-3D - Right hand rail assembly kit			
B	1026883	Rail, right hand	1
C	1026880	Stiffener	1
D	SC-25018	Screw, 1/4-20 x 1-1/8" Flat Hd	3
E	NU-29475	Nut, 1/4-20 KEPS, S/S	3
F	BG-24890	Bearing	3

Part numbers and drawings are subject to change without notice.

**For builds prior to August 1, 2018, please consult the Alto-Shaam website (alto-shaam.com)**

500-D Drawer Assembly

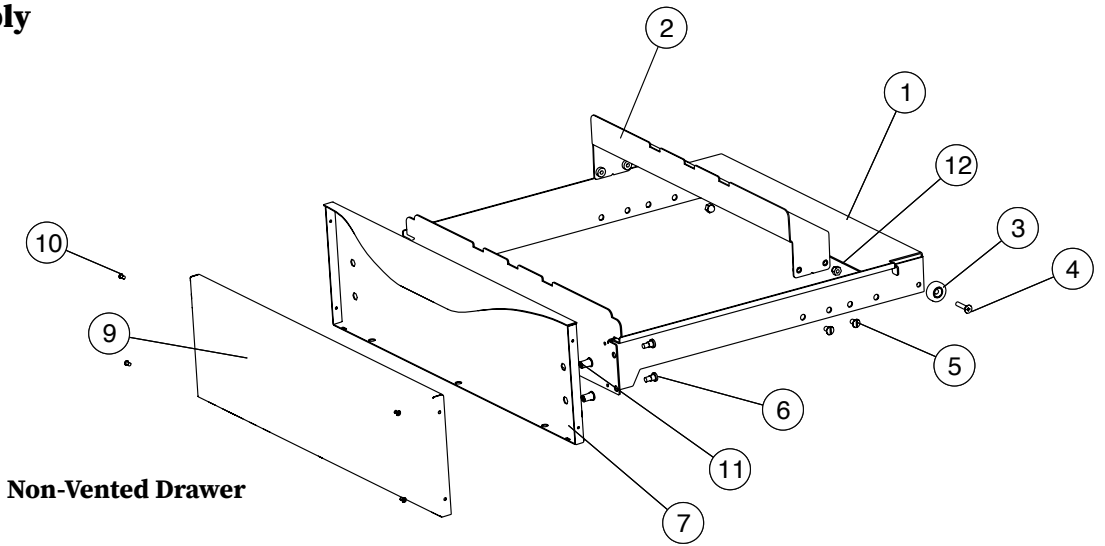

Non-Vented Drawer

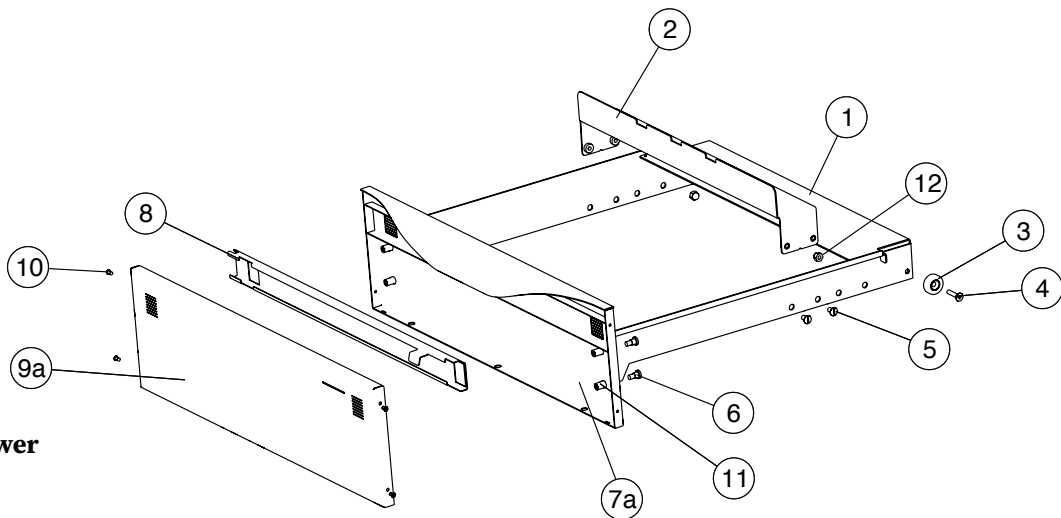

Vented Drawer

Part numbers and drawings are subject to change without notice.

Item	Part	Description	Qty
1	5017810	DRAWER FRAME SPOT	1
2	5013916	PAN SUPPORT	1
3	BG-24890	BEARING, ROLLER	1
4	SC-25018	SCREW, 1/4-20 x 1-1/8" FLAT HD	2
5	ST-2546	STUD, SHOULDER, SHORT, S/S	4
6	ST-25019	STUD, S/S PIVOT	4
7	5013917	DRAWER INNER W/HANDLE	1
7a	5014558	VENTED DRAWER FRONT SPOT	1
8	1019159	VENT SLIDE	1
9	16467	DRAWER, OUTER	1
9a	1012899	VENTED DRAWER, OUTER	1
10	RI-2100	RIVET, BLIND, #44, S/S	4
11	NU-36239	NUT, INSERT, THREADED, 1/4-20	4
12	NU-2187	NUT, 1/4-20, NC ACORN #18-8, S/S	2

For builds prior to August 1, 2018, please consult the Alto-Shaam website (alto-shaam.com)

# Service

## 500-DN Narrow Exterior

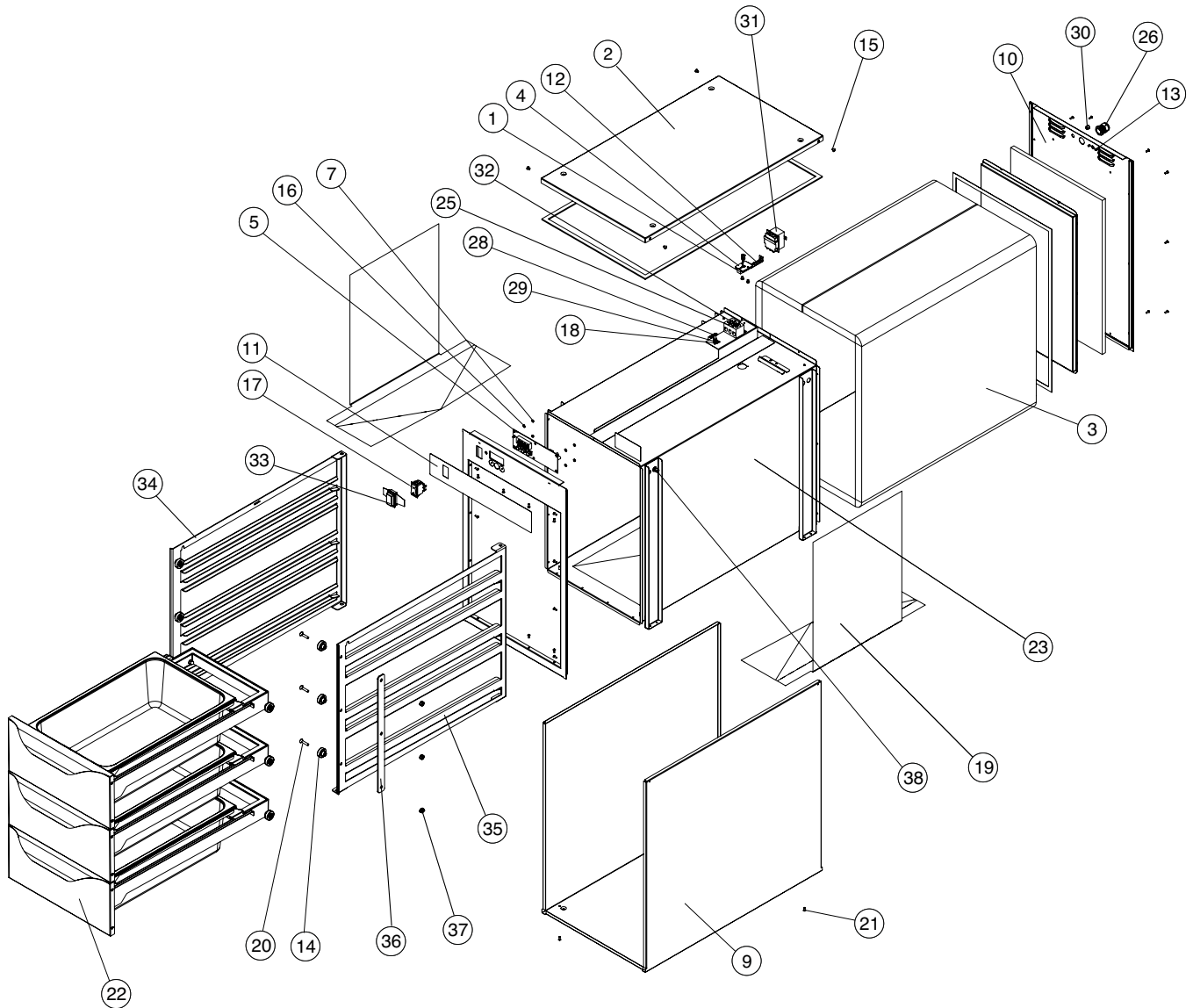

Part numbers and drawings are subject to change without notice.

**⚠ WARNING**

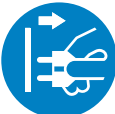

To prevent serious injury, death, or property damage, **always** disconnect the appliance from the power source before cleaning or servicing.

**⚠ DANGER**



To prevent serious injury, death, or property damage, **always** lock-out or post breaker panel until service work has been completed.

**For builds prior to August 1, 2018, please consult the Alto-Shaam website ([alto-shaam.com](http://alto-shaam.com))**



**500-DN Narrow Exterior Parts List**

Item	Part	Description	Qty
1	1493	BRACKET, SENSOR MTG.	1
2	1012779	TOP COVER	1
3	IN-2003	INSULATION	1
4	BK-29605	CONTROL SENSOR BLOCK	1
5	CC-34970	WARMER CONTROL	1
6	GS-23622	GASKET ADHESIVE 0.125 x 0.375 [lin ft]	1
7	NU-2361	NUT, 6-32 HEX, S/S	4
8	1026919	INNER BACK PANEL, 500-3DN	1
	1026854	INNER BACK PANEL, 500-2DN	1
	1012797	INNER BACK PANEL, 500-1DN	1
9	1027232	OUTER CASING, 500-3DN	1
	1027233	OUTER CASING, 500-2DN	1
	1012795	OUTER CASING, 500-1DN	1
10	1012781	REAR TRIM, 500-3DN	1
	1012791	REAR TRIM, 500-2DN	1
	1012796	REAR TRIM, 500-1DN	1
11	PE-29686	PANEL OVERLAY	1
12	SN-38111	SENSOR	1
13	SC-22271	SCREW, M4-0.7 x 6mm PHIL	2
14	BG-24890	BEARING, DRAWER WARMER	4
15	SC-2459	SCREW, 8-32 x 1/4" PHIL SCREW	4
16	WS-23148	WASHER, 6-32, FLAT, NYL	4
17	SW-34769	SWITCH, ROCKER, 125-277V, 20A	1
18	WS-2467	WASHER, INT. LOCK	1
19	EL-29738	ELEMENT, 320W, FOIL PAD HEATER	2
20	SC-25018	SCREW, 1/4-20 x 1-1/8" FLAT HD	6
21	RI-38125	RIVET, SEALED, .125, SST, DOME HD	2
22	5014435R	DRAWER FRAME ASSEMBLY	1
	5014561R	DRAWER FRAME ASSEMBLY, VENTED	1
23	5026540	TUBE SPOT ASSEMBLY, 500-3DN	1
	5026541	TUBE SPOT ASSEMBLY, 500-2DN	1
	5014431	TUBE SPOT ASSEMBLY, 500-1DN	1
24*	1003936	HI-LIMIT PROTECTION COVER	1
25	BK-3019	T-BLOCK	1
26	BU-3964	BUSHING, STRAIGHT, STRAIN RELIEF	1
27*	CD-3232	CORDSET, 14/3 SJTOW, 125V	1
28	CR-34646	CONNECTOR-5 CONDUCTOR	2
29	SC-36973	SCREW, PAN PH, METRIC, M5	1
30	PG-25574	3/8" HOLE PLUG	1
31	TT-33476	THERMOSTAT, 300°F HI-LIMIT	1
32	SC-2365	SCREW, 6-32 x 1-1/4" ROUND HEAD	2
33	CV-38297	SWITCH COVER (230V ONLY)	1
34	5026336R	RAIL SERVICE KIT, LEFT, 500-3DN	1
	5026316R	RAIL SERVICE KIT, LEFT, 500-2DN	1
35	5026339R	RAIL SERVICE KIT, RIGHT, 500-3DN	1
	5026320R	RAIL SERVICE KIT, RIGHT, 500-2DN	1
36	1026880	STIFFENER, RAIL ASSEMBLY, 500-3DN	2
	1026774	STIFFENER, RAIL ASSEMBLY, 500-2DN	2
37	NU-29475	NUT, 1/4-20, KEPS, S/S	4
38	SC-39699	SCREW, SOCKET, SHOULDER 1/4-20"	2

**Rail Service Kits - 500-2D, 500-3D**

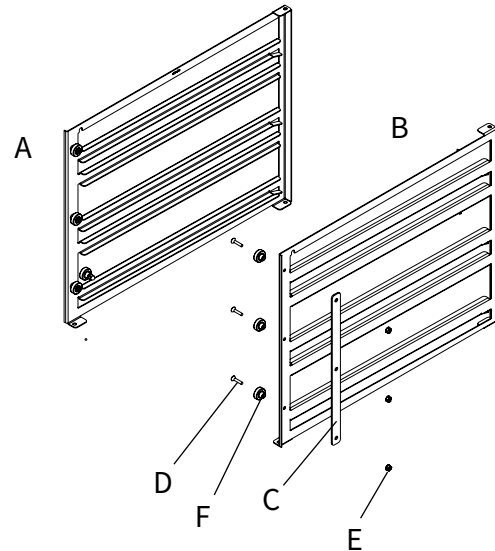

5026316R - 500-2DN - Left hand rail assembly kit			
Item	Part	Description	Qty
A	1026728	Rail, left hand	1
C	1026774	Stiffener	1
D	SC-25018	Screw, 1/4-20 x 1-1/8" Flat Hd	2
E	NU-29475	Nut, 1/4-20 KEPS, S/S	2
F	BG-24890	Bearing	2
5026320R - 500-2DN - Right hand rail assembly kit			
B	1026783	Rail, right hand	1
C	1026774	Stiffener	1
D	SC-25018	Screw, 1/4-20 x 1-1/8" Flat Hd	2
E	NU-29475	Nut, 1/4-20 KEPS, S/S	2
F	BG-24890	Bearing	2
5026336R - 500-3DN - Left hand rail assembly kit			
A	1026879	Rail, left hand	1
C	1026880	Stiffener	1
D	SC-25018	Screw, 1/4-20 x 1-1/8" Flat Hd	3
E	NU-29475	Nut, 1/4-20 KEPS, S/S	3
F	BG-24890	Bearing	3
5026339R - 500-3DN - Right hand rail assembly kit			
B	1026883	Rail, right hand	1
C	1026880	Stiffener	1
D	SC-25018	Screw, 1/4-20 x 1-1/8" Flat Hd	3
E	NU-29475	Nut, 1/4-20 KEPS, S/S	3
F	BG-24890	Bearing	3

Part numbers and drawings are subject to change without notice.

**For builds prior to August 1, 2018, please consult the Alto-Shaam website (alto-shaam.com)**

# Service

## 500-DN Narrow Drawer Assembly

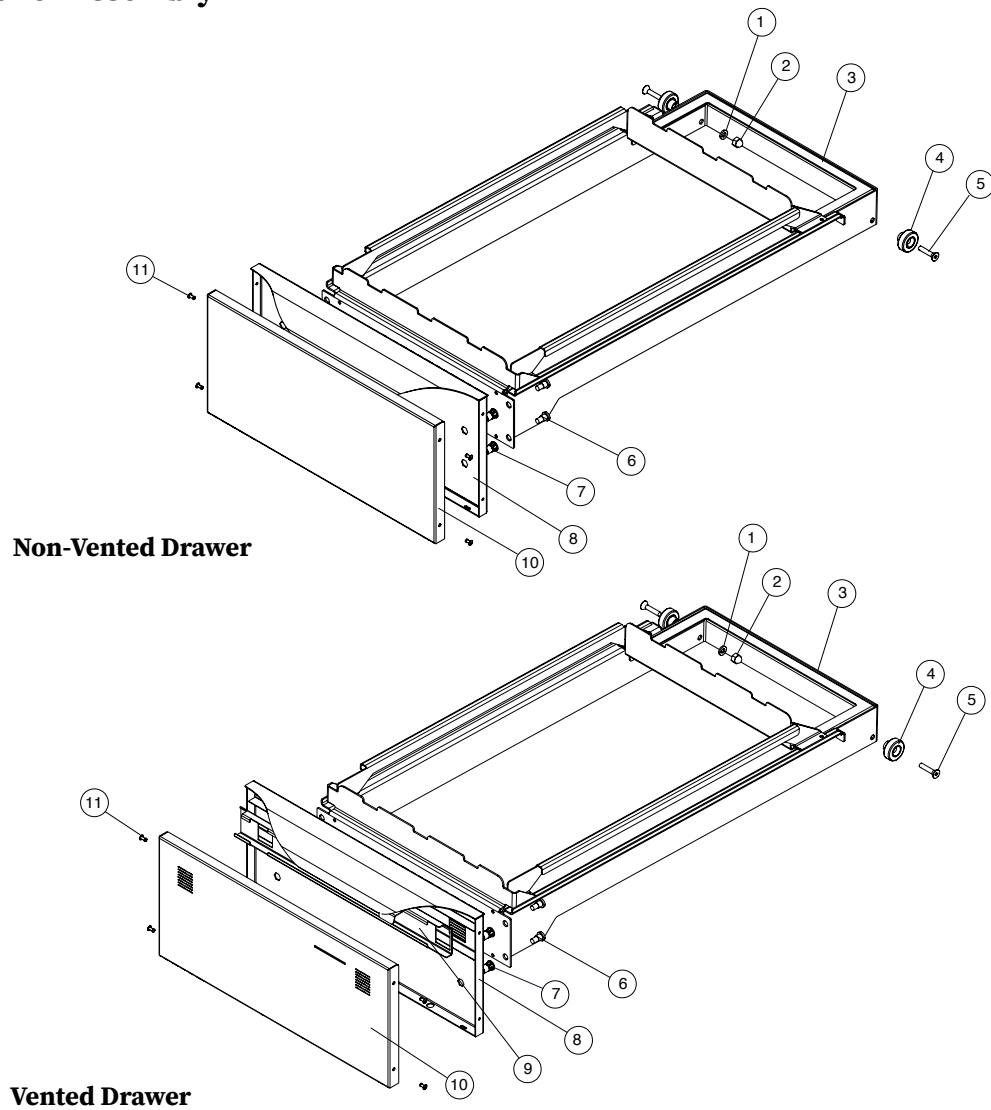

Part numbers and drawings are subject to change without notice.

Item	Part	Description	Qty
1	WS-2294	WASHER, 1/4" LOCK	2
2	NU-2187	NUT, 1/4-20 NC ACORN #18-8 S/S	2
3	5017809	DRAWER FRAME	1
4	BG-24890	BEARING, DRAWER WARMER	2
5	SC-25018	SCREW, 1/4-20 x 1-1/8" FLAT HD	2
6	ST-25019	STUD, S/S PIVOT	4
7	NU-36239	NUT, INSERT, THREADED, 1/4-20	4
8	5014560	DRAWER FRONT SPOT	NON-VENTED DRAWER 1
	5014439		VENTED DRAWER 1
9	1019169	VENT SLIDE	1
10	1012804	OUTER DRAWER	NON-VENTED DRAWER 1
	1012901		VENTED DRAWER 1
11	RI-2100	RIVET, BLIND, #44, S/S	4

**For builds prior to August 1, 2018, please consult the Alto-Shaam website (alto-shaam.com)**

500-D, 500-DN Electrical

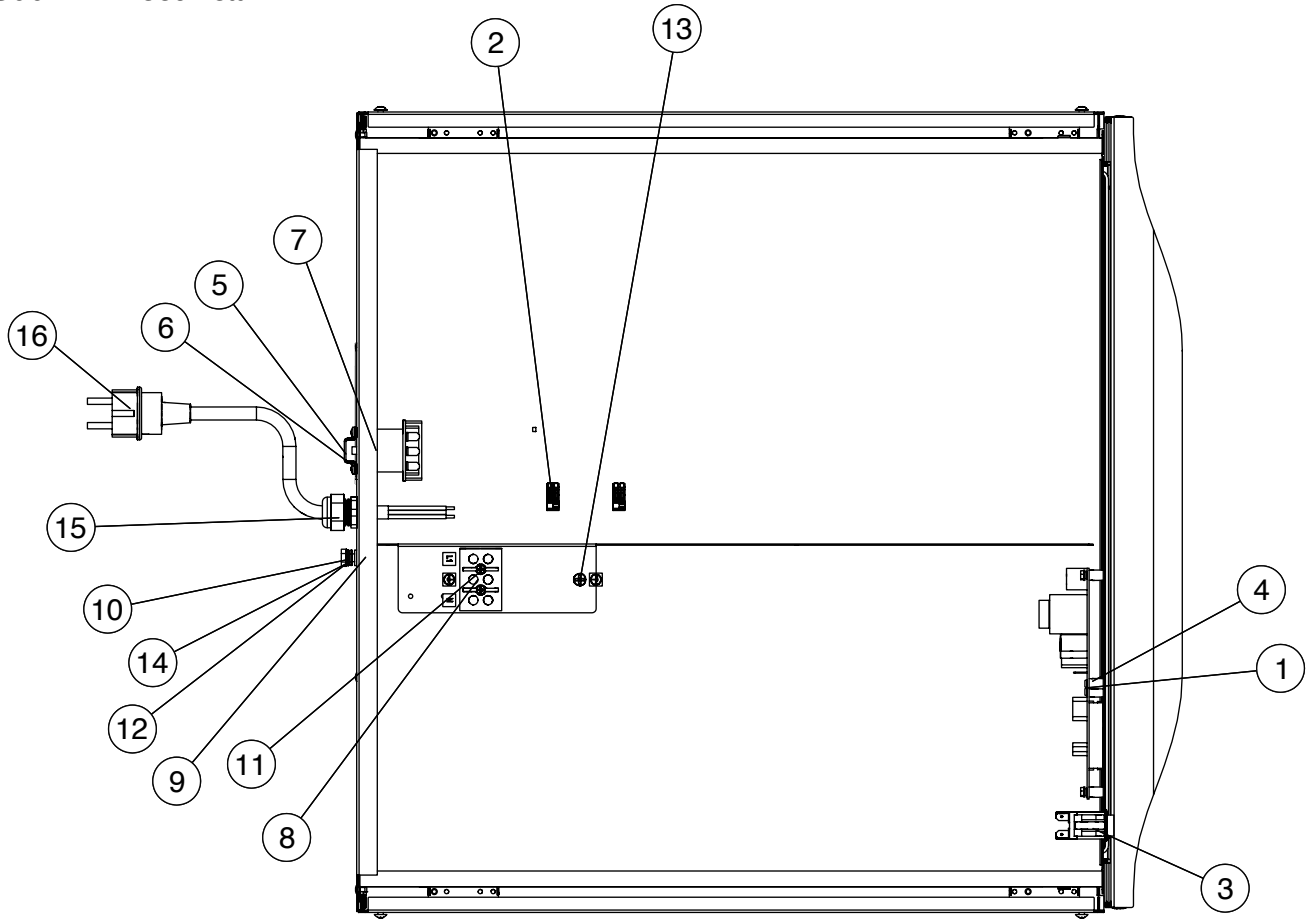

Item	Part	Description	Qty
1	CC-34970	WARMER CONTROL	1
2	CR-34967	CONNECTOR-2 CONDUCTOR	2
3	SW-34769	SWITCH, ROCKER, 125-277V, 20A	1
4	SP-29392	SPACER, SNAP-IN, 7/16	6
5	1003936	HI-LIMIT PROTECTION COVER	1
6	SC-22271	SCREW, M4-0.7 x 6mm PHIL	2
7	TT-33476	THERMOSTAT, 300F HI-LIMIT	1
8	BK-3019	T-BLOCK	1
9	NU-22770	NUT, THREADED INSERT, M6	1
10	SC-22924	SCREW, HHCS, M6 X 20, W/NO MARKING	1
11	SC-2365	SCREW, 6-32 X 1 1/4" ROUND HD	2

Item	Part	Description	Qty
12	WS-22297	WASHER, FLAT	2
13	SC-36973	SCREW, PAN PH, METRIC, M5	1
14	WS-22302	WASHER, SPLIT LOCK	2
15	BU-3964	BUSHING, STRAIGHT, STRAIN RELIEF	1
16	5015002	NEMA 5-15P CORDSET, 120V	1
	5017194	NEMA 6-15P CORDSET, 208-240V	1
	5013670	CEE 7/7 CORDSET, 230V	1
	5014997	BS 1363 CORDSET, 230V	1
	5016998	CH2-16P CORDSET, 230V	1
	5020353	AS/NZS 3112 CORDSET, 230V	1

Part numbers and drawings are subject to change without notice.

WARNING

To prevent serious injury, death, or property damage, **always** disconnect the appliance from the power source before cleaning or servicing.

DANGER

To prevent serious injury, death, or property damage, **always** lock-out or post breaker panel until service work has been completed.

# Service

## 500-2DI Exterior

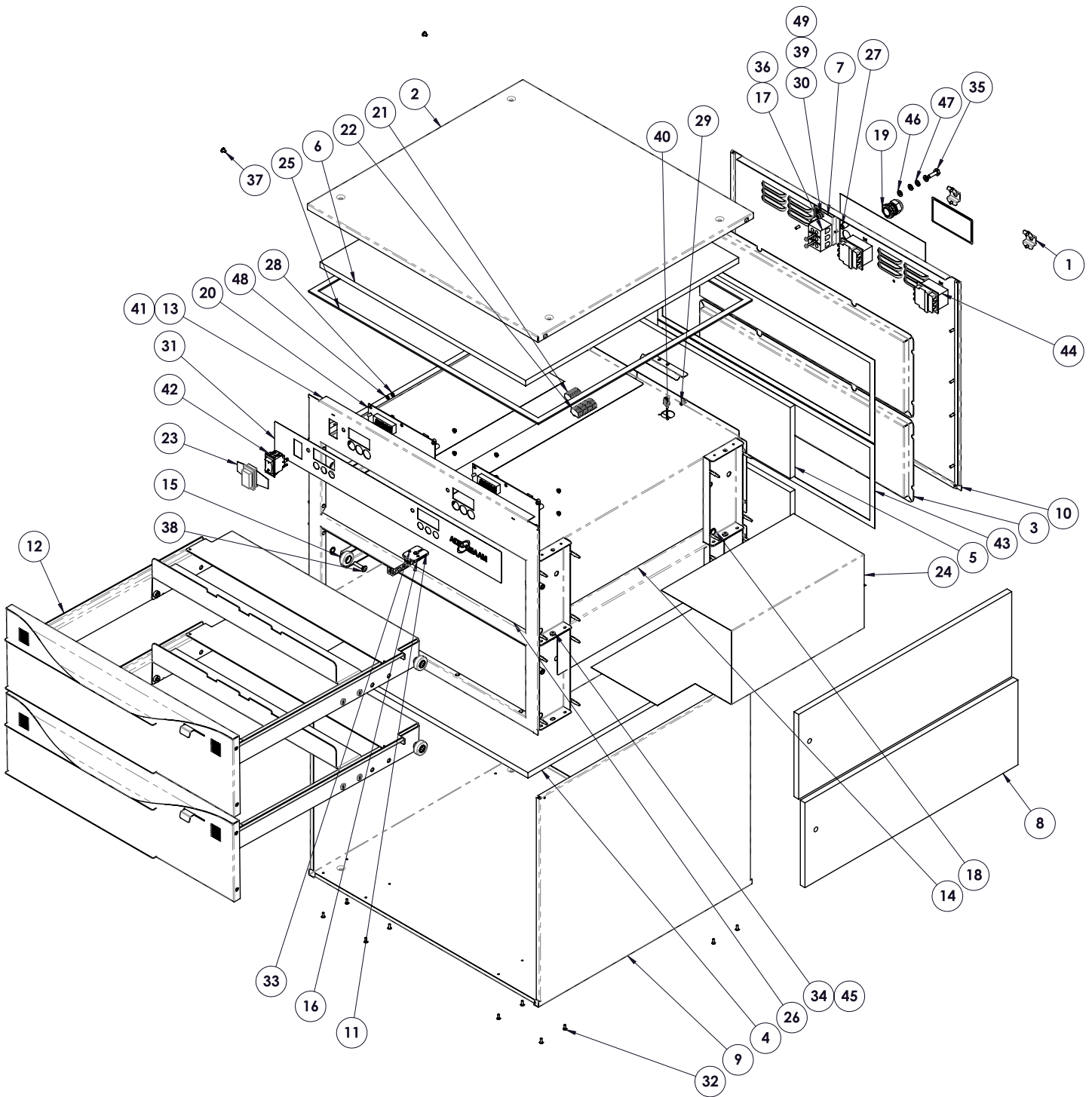

Part numbers and drawings are subject to change without notice.

## 500-2DI Exterior Parts List

Item	Part No.	Description	Qty
1	1003936	HI-LIMIT PROTECTION COVER	2
2	1012473	COVER, TOP	1
3	1012667	PANEL, INNER BACK	2
4	1017521	INSULATION, BOTTOM,	1
5	1017529	INSULATION, BACK	2
6	1022418	INSULATION, TOP	1
7	1025247	BRACKET, OFFSET, TERMINAL	1
8	1025252	INSUL, SIDE, 7.750" x 22.485"	4
9	1026119	CASING, OUTER	1
10	1026121	TRIM, REAR	1
11	1493	SENSOR GUARD	2
12	5014559	FRAME, VENTED DRAWER ASSEMBLY	2
13	5025390	TRIM, FRONT, STUD ASSEMBLY	1
14	5025401	TUBE, ASSEMBLY, SPOTWELD	2
15	BG-24890	BEARING, ROLLER	4
16	BK-29605	BLOCK, SENSOR, ELEC. CONTROL	2
17	BK-3019	T-BLOCK	1
18	BU-3006	BUSHING, 1/2" HOLE	1
19	BU-3964	BUSHING, STRAIGHT, STRAIN RELIEF	1
20	CC-34970	CONTROL	2
21	CR-34646	CONNECTOR-5 CONDUCTOR	1
22	CR-34967	CONNECTOR-2 CONDUCTOR	4
23	CV-38297	SWITCH COVER	1
24	EL-29875	ELEMENT, 320W, FOIL PAD HEATER	4
25	GS-23622	GASKET, WITH ADHESIVE 0.125 x 0.375 [lin ft]	1
26	IN-2381	INSULATION, 1.5" THICK, 22.5 x 21.7	1
27	NU-22770	NUT, THREADED INSERT, M6	1
28	NU-2361	NUT, 6-32 HEX, S/S	8
29	NU-26866	NUT, HEX INSERT M4	20
30	NU-36234	NUT, M5, KEPS	3
31	PE-39429	PANEL OVERLAY	1
32	RI-38125	RIVET, SEALED, .125"	42
33	SC-22271	SCREW, M4-0.7 x 6mm PHIL	8
34	SC-22273	SCREW, M4 x 0.7 x 10mm PAN	20
35	SC-22924	SCREW, HHCS, M6 x 20	1
36	SC-2365	SCREW, 6-32 x 1-1/4", NC PHILLIPS	2
37	SC-2459	SCREW, 8-32 x 1/4" PHIL	4
38	SC-25018	SCREW, 1/4-20 x 1 1/8" FLAT HD	4
39	SC-38128	SCREW, PAN PH, METRIC, M5	1
40	SN-38111	SENSOR, 1000 OHM, 110" WIRE	2
41	SP-29392	SPACER, SNAP-IN, 7/16"	12
42	SW-34769	SWITCH, ROCKER, 125-277V, 20A	1
43	TA-24637	TAPE, DOUBLE SIDED, 5.1 Ft	2
44	TT-33476	THERMOSTAT, 300F HI-LIMIT	2
45	WS-22295	WASHER, FLAT M5 S/S	4
46	WS-22297	WASHER, FLAT	2
47	WS-22302	WASHER, SPLIT LOCK	2
48	WS-23148	WASHER, 6-32, FLAT, NYL	8
49	WS-2467	WASHER, INT. LOCK	1

Part numbers and drawings are subject to change without notice.

# Service

## 500-2DI Electrical

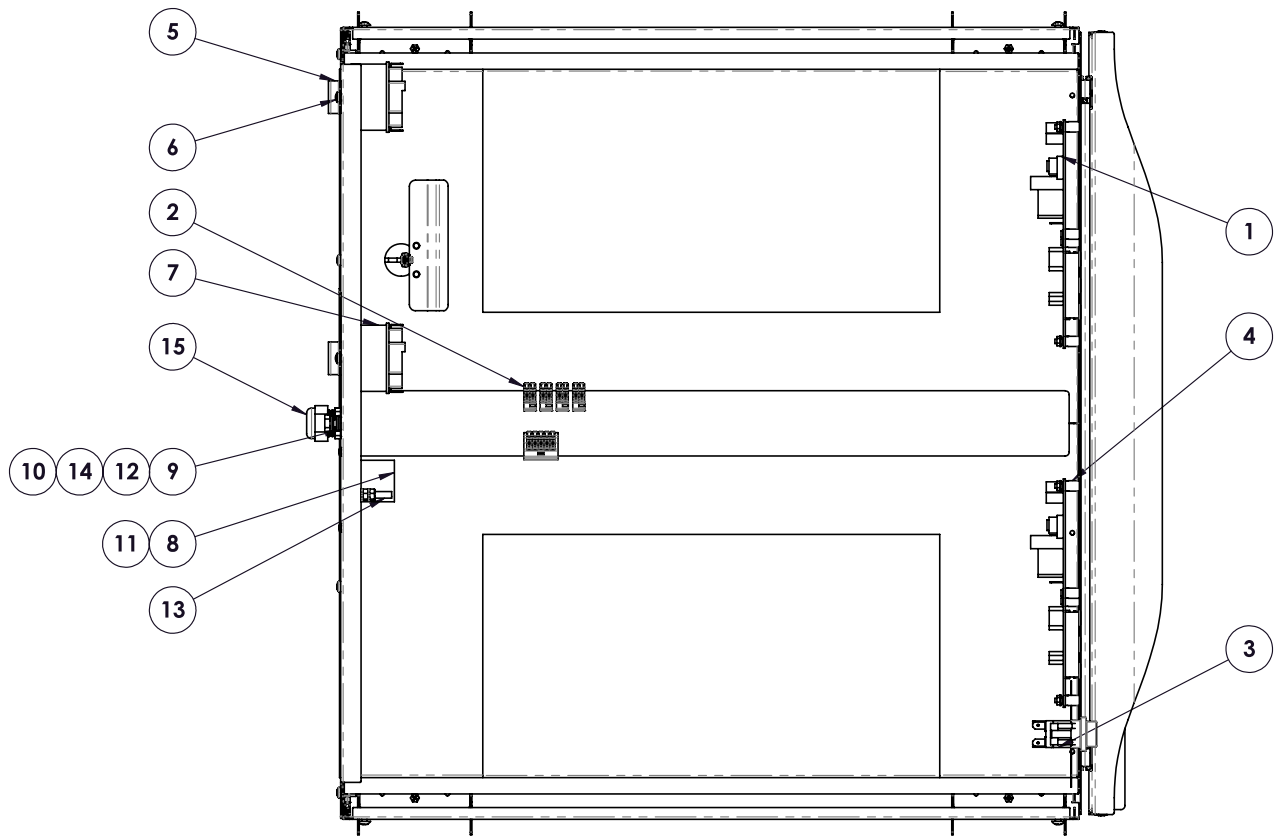

Item	Part No.	Description	Qty
1	CC-34970	CONTROL	2
2	CR-34967	CONNECTOR-2 CONDUCTOR	4
3	SW-34769	SWITCH, ROCKER, 125-277V, 20A	1
4	SP-29392	SPACER, SNAP-IN, 7/16"	12
5	1003936	HI-LIMIT PROTECTION COVER	2
6	SC-22271	SCREW, M4-0.7 x 6mm PHIL	8
7	TT-33476	THERMOSTAT, 300F HI-LIMIT	2
8	BK-3019	T-BLOCK	1
9	NU-22770	NUT, THREADED INSERT, M6	1
10	SC-22924	HHCS, M6 x 20, W/NO MARKING	1
11	SC-2365	SCREW, 6-32 x 1-1/4, NC PHILLIPS	2
12	WS-22297	WASHER, FLAT	2
13	SC-38128	SCREW, PAN PH, METRIC, M5	1
14	WS-22302	WASHER, SPLIT LOCK	2
15	BU-3964	BUSHING, STRAIGHT, STRAIN RELIEF	1

Part numbers and drawings are subject to change without notice.

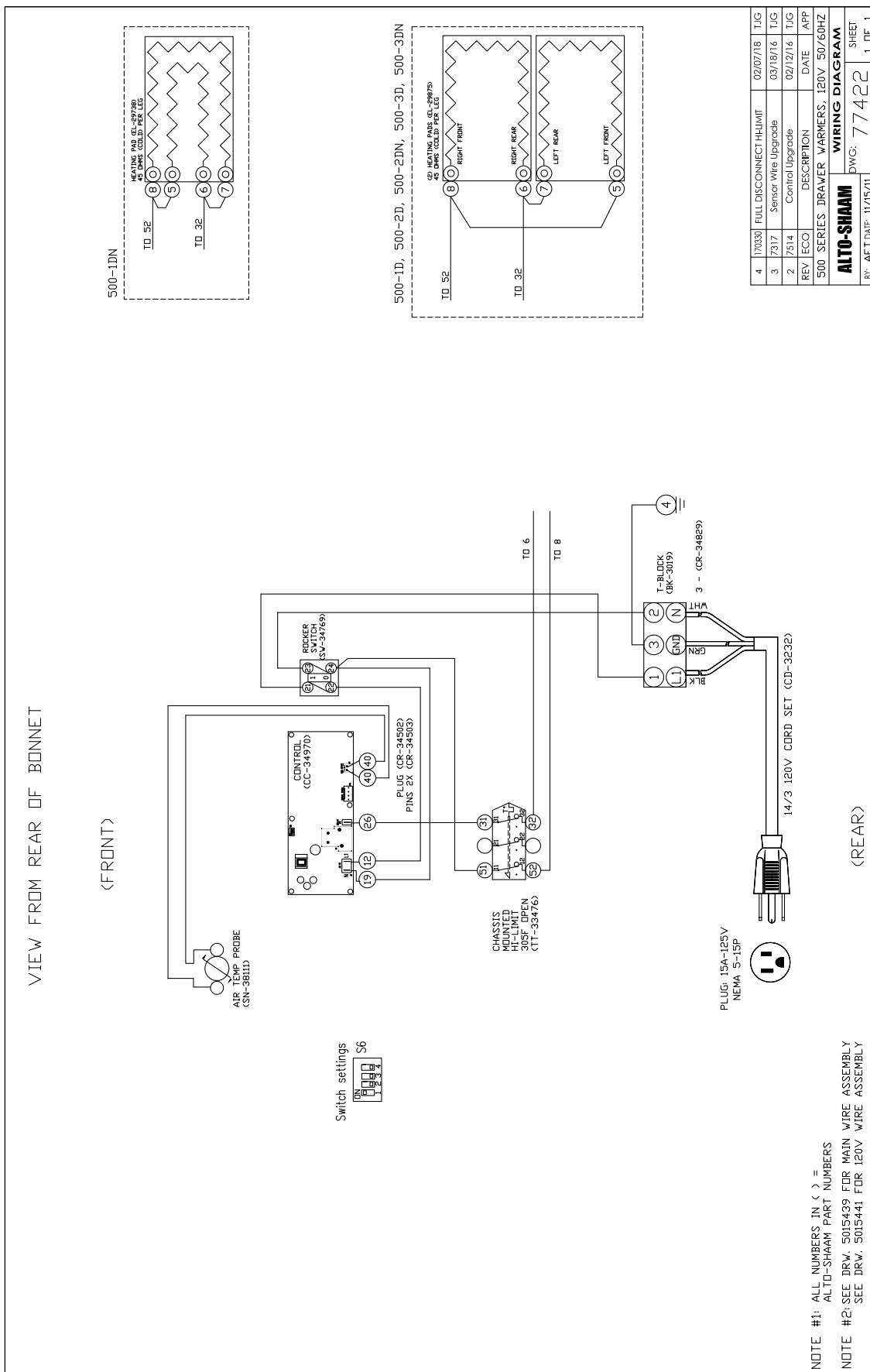

# Wiring Diagrams

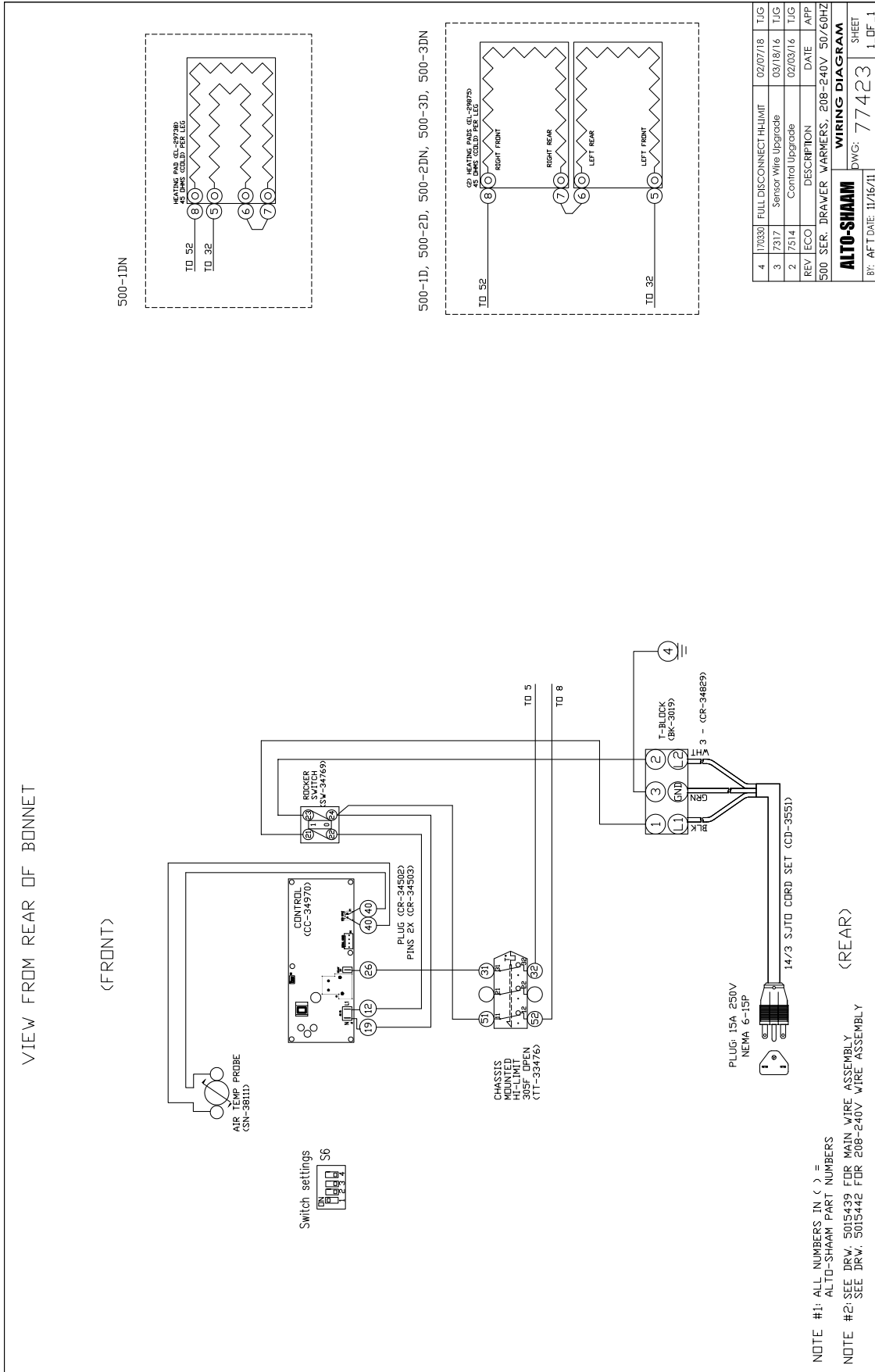



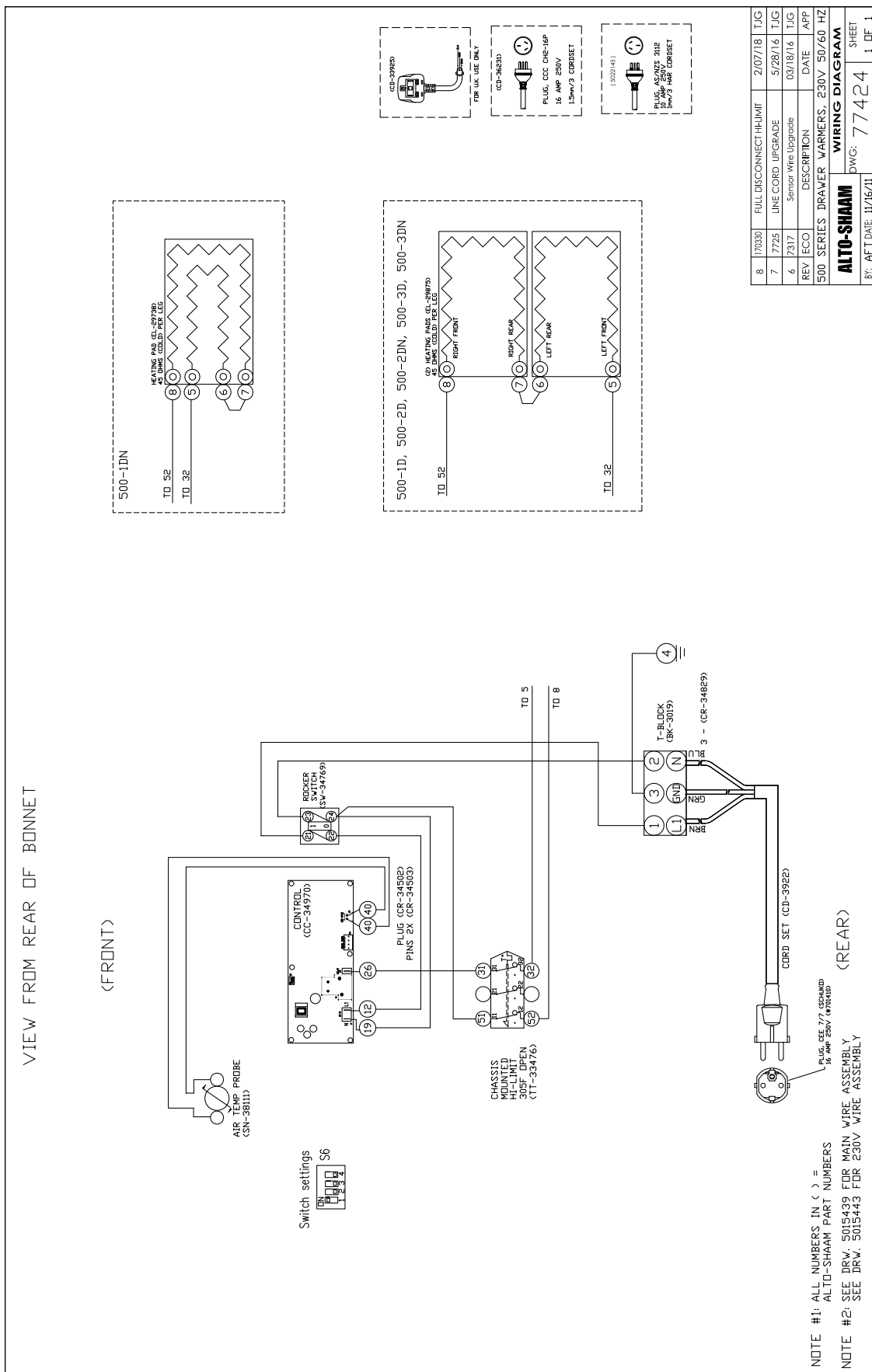

# Wiring Diagrams

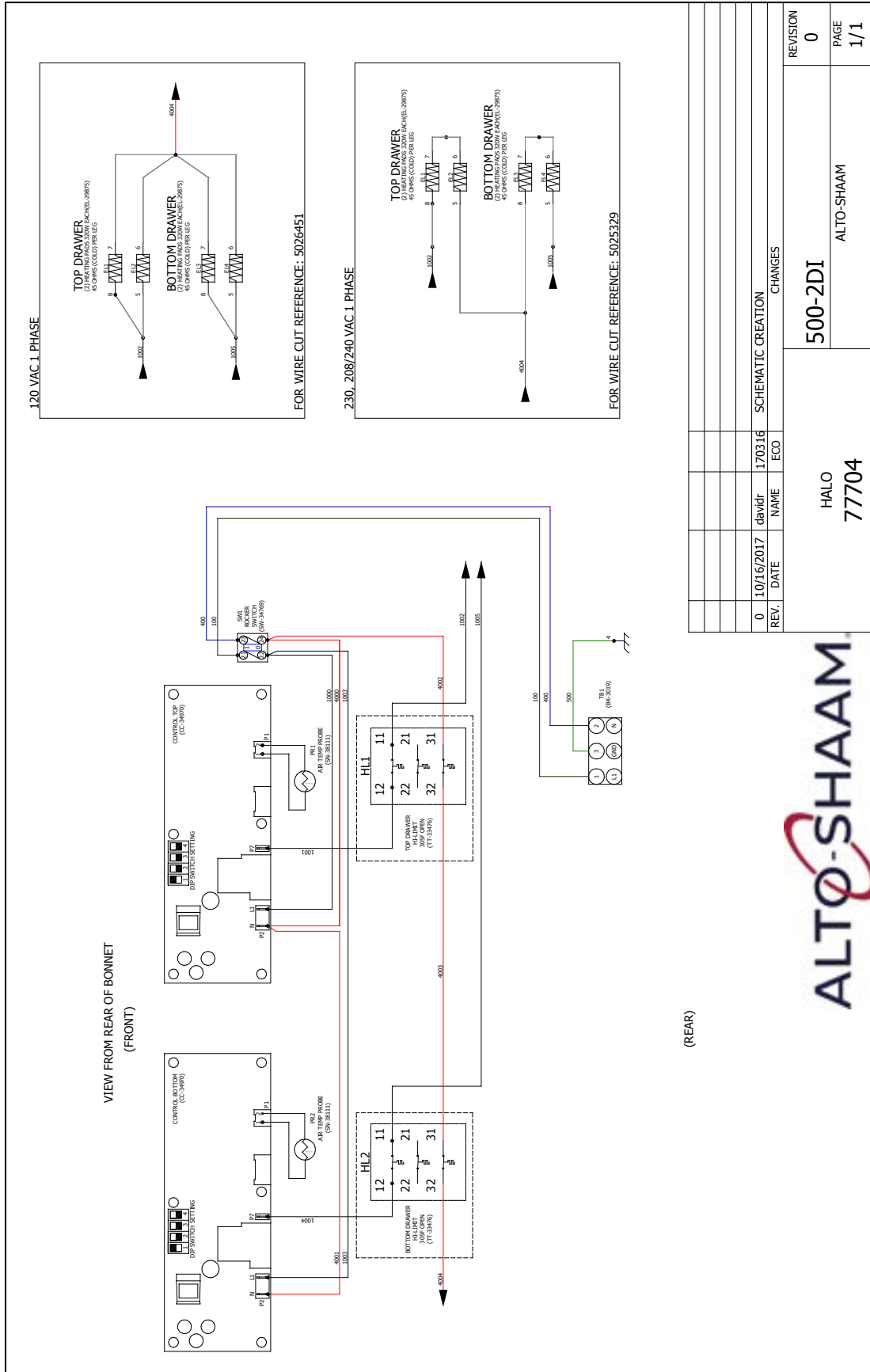

REV.	DATE	NAME	ECO	CHANGES	REVISION	PAGE
0	10/16/2017	davidr	170316	SCHEMATIC CREATION	0	1/1
					500-2DI	ALTO-SHAAM
					HALO 77704	



SOLIDWORKS Electrical

Document released with version: 2017.0.5.7

Alto-Shaam, Inc. warrants to the original purchaser only that any original part that is found to be defective in material or workmanship will, at Alto-Shaam's option, subject to provisions hereinafter stated, be replaced with a new or rebuilt part.

**The original parts warranty period is as follows:**

For the refrigeration compressor on Alto-Shaam Quickchillers™, five (5) years from the date of installation of appliance.

For the heating element on Halo Heat® cooking and holding ovens, as long as the original purchaser owns the oven. This excludes holding only equipment.

For all other original parts, one (1) year from the date of installation of appliance or fifteen (15) months from the shipping date, whichever occurs first.

The labor warranty period is one (1) year from the date of installation or fifteen (15) months from the shipping date, whichever occurs first.

Alto-Shaam will bear normal labor charges performed during standard business hours, excluding overtime, holiday rates or any additional fees.

To be valid, a warranty claim must be asserted during the applicable warranty period. This warranty is not transferable.

**This warranty does not apply to:**

1. Calibration.
2. Replacement of light bulbs, door gaskets, and/or the replacement of glass due to damage of any kind.
3. Equipment damage caused by accident, shipping, improper installation or alteration.
4. Equipment used under conditions of abuse, misuse, carelessness or abnormal conditions, including but not limited to, equipment subjected to harsh or inappropriate chemicals, including but not limited to, compounds containing chloride or quaternary salts, poor water quality, or equipment with missing or altered serial numbers.
5. Damage incurred as a direct result of poor water quality, inadequate maintenance of steam generators and/or surfaces affected by water quality. Water quality and required maintenance of steam generating equipment is the responsibility of the owner/operator.
6. Damage caused by use of any cleaning agent other than Alto-Shaam's Combitherm® Cleaner, including but not limited to damage due to chlorine or other harmful chemicals. **Use of Alto-Shaam's Combitherm® Cleaner on Combitherm® ovens is highly recommended.**
7. Any losses or damage resulting from malfunction, including loss of product, food product, revenue, or consequential or incidental damages of any kind.
8. Equipment modified in any manner from original model, substitution of parts other than factory authorized parts, removal of any parts including legs, or addition of any parts.

This warranty is exclusive and is in lieu of all other warranties, express or implied, including the implied warranties of merchantability and fitness for a particular purpose. In no event shall Alto-Shaam be liable for loss of use, loss of revenue or profit, or loss of product, or for any indirect, special, incidental, or consequential damages. No person except an officer of Alto-Shaam, Inc. is authorized to modify this warranty or to incur on behalf of Alto-Shaam any other obligation or liability in connection with Alto-Shaam equipment.

Effective November 1, 2012