



**John
BOOS**
Since 1887

ITEM #: _____ QTY: _____
 MODEL #: _____
 PROJECT NAME: _____

101518

3601 S. Banker St. Effingham, IL 62401 • P.O. BOX 609 • Ph: (888) 431-2667 • Fax: (800) 433-2667

"C2HB" VENTLESS CONDENSATE HOOD



FEATURES:

- 18 GAUGE STAINLESS STEEL CONSTRUCTION
- FULL PERIMETER GUTTER
- REMOVABLE CONDENSATE BAFFLE
- REAR DRAIN TUBE
- WELDED HANGING BRACKETS
- **NOTE: CHECK LOCAL CODES FOR APPROVAL**

MATERIAL:

- HOOD: 18 GAGE TYPE 300 STAINLESS STEEL
- BAFFLE: 18 GAUGE TYPE 300 STAINLESS STEEL

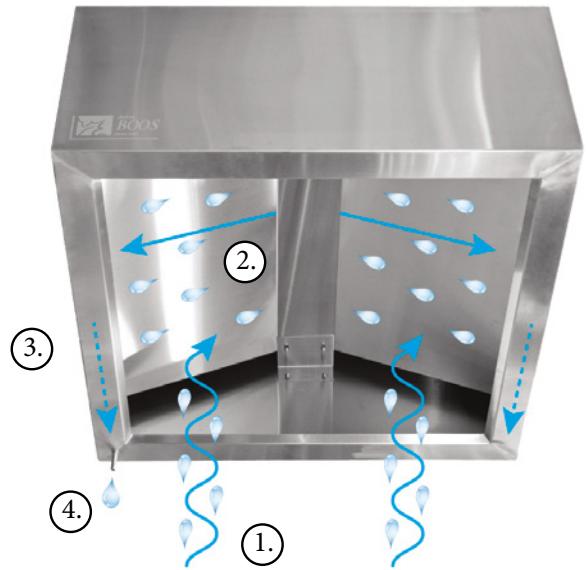

CONDENSATION HOOD FUNCTIONALITY

1. CONDENSATION RISES
2. HITS INNER BAFFLE
3. DRIPS ONTO GUTTER
4. EXITS THROUGH REAR DRAIN TUBE

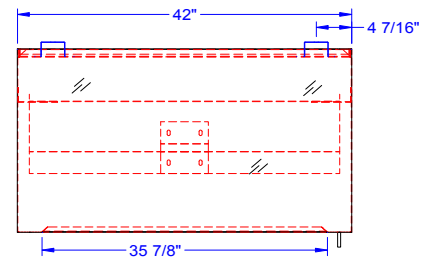
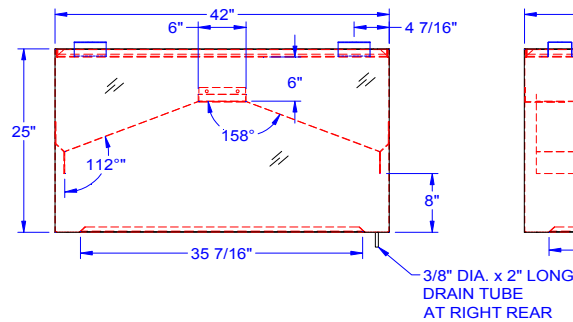
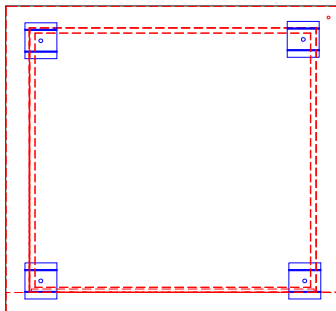

CONDENSATE HOOD

MODEL #	LENGTH	WIDTH	HEIGHT	WT. (LBS)	QTY
C2HB-42-2	42"	42"	25"	42	

WEIGHTS ARE SUBJECT TO ADDITIONAL PACKAGING

SOME UNITS SHIP UNASSEMBLED FOR REDUCED SHIPPING COST. ALL DIMENSIONS ARE TYPICAL. TOLERANCE +/- .500"

John Boos & Co. is constantly engaged in a program of improving products and therefore reserves the right to change specifications without prior notice.

