



SkyLine PremiumS Natural Gas Boiler Combi Oven 62 120V

ITEM # _____
 MODEL # _____
 NAME # _____
 SIS # _____
 AIA # _____



219781 (ECOG62T300)

SKYLINE PREMIUMS 6
FULL SHEET PANS (18" X
26")TOUCH-GAS 120V-
BOILER

Short Form Specification

Item No. _____

Combi oven with high resolution full touch screen interface, multilanguage, IPX5, ETL, EnergyStar, Ergocert

- Built-in BOILER (in s/s 316L) with Lambda Sensor
- OptiFlow: air distribution system with 7 fan speed levels
- SkyClean: Automatic and built-in self cleaning system with integrated descale of the steam generator.
- 3 Cooking modes: Automatic, Programs, Manual
- Special functions: MultiTimer cooking, Plan-n-Save, SkyHub homepage, agenda MyPlanner, SkyDuo connection to SkyLine ChillerS, automatic backup mode to avoid downtime
- USB port to download HACCP data, programs and settings. Connectivity to the cloud ready
- 6-point multi sensor core temperature probe
- Triple-glass door with double LED lights line

Main Features

- Touchscreen: High resolution interface (translated into more than 30 languages including Spanish and French) - color-blind friendly panel.
- Built-in steam generator: Boiler in AISI 316 steel for highly precise humidity and temperature control according to the chosen settings.
- Lambda Sensor: Real humidity control of +-1% for automatic quantity and size of food recognition to guarantee consistent cooking results
- Dry, hot convection cycle (77 °F - 575 °F/25 °C - 300 °C): ideal for convection cooking.
- Combi cycle (77 °F - 575 °F/25 °C - 300 °C): The combination of hot air and steam creating a humidity controlled cooking environment, to reduce the cooking process times and food weight loss.
- Steam cycle (77 °F - 266°F/25 °C - 99 °C): Ideal for sous vide, re-thermalization, and Low Steaming of food and vegetables
- Automatic Cooking Mode: includes 9 food families (meat, poultry, fish, vegetables, pasta/rice, eggs, pastries and sweet bakery, bread, dessert) with 100+ different pre-installed variations. The Automatic Sensory Phase of the oven optimizes the cooking process according to the size, quantity and type of food loaded in the oven. Real-time monitoring of cooking parameters. Personalize and save up to 70 variations per food family.
- Cycles+: Regeneration (ideal for banqueting on plate or rethermalizing on tray)
 - Low Temperature Cooking (to minimize weight loss and maximize food quality) Patented US7750272B2 and related family
 - Proving cycle
 - EcoDelta cooking, cooking with the difference between the food probe core temperature of the food and the cooking cavity
 - Sous-vide cooking
 - Static Combi (to reproduce traditional cooking from static oven)
 - Pasteurization of pasta
 - Dehydration cycles (ideal for drying fruits, vegetables, meats, seafood)
 - Food safe Control and Advanced Food Safe Control: to automatically monitor safely the cooking process in compliance with HACCP hygienic standards or drive cooking with pasteurization factor Patented US6818865B2 and related family
- Programs mode: a maximum of 1000 recipes can be stored in the oven's memory, to recreate the exact same recipe at any time. The recipes can be group in 16 different categories to better organize the menu. 16-step cooking programs also available.
- MultiTimer: Special feature to manage up to 20 different cooking cycles at the same time in the same cavity guaranteeing even cooking results. Up to 200 MultiTimer available programs
- OptiFlow: air flow management system to achieve maximum performance in cooking evenness and temperature control thanks to the special design of the cooking chamber, the high precision variable speed fan and the venting valve.



APPROVAL: _____

SkyLine PremiumS
Natural Gas Boiler Combi Oven 62 120V

- Reversible Fan: 7 speed fan levels from 300 to 1500 RPM with reverse rotation for optimal evenness. Fan stops in less than 5 seconds when door is opened.
- 6-point multi sensor core temperature probe for maximum precision and food safety.
- Picture Management: upload full customized images of cooking cycles or food items
- Automatic cool-down and pre-heat function
- Reduced-Power Feature: To consume less energy during customized slow cooking cycles.
- SkyClean: Automatic self cleaning system with integrated descaling of the steam boiler. 5 automatic cycles (soft, medium, strong, extra strong, rinse-only) and green functions to save energy, water, detergent and rinse aid. Also programmable with delayed start.
- 2 cleaning detergent option available: the standard, solid and liquid as an option (requires accessory)
- Plan-n-Save: the oven organizes the sequence of the chosen cooking cycles to optimize the processes in the kitchen reducing time and energy consumption.
- Make-it-mine: feature to allow full personalization or locking of the user interface by selecting what is visible on screen
- SkyHub: customizable homepage to allow the user to group their favorite functions for immediate access when operating.
- MyPlanner: on-screen agenda where the user can plan their daily work, set reminders for several users and receive personalized alerts for each activity
- SkyDuo: Oven and Blast Chiller automatic communication to guide the user through the cook&chill process by creating a safe controlled environment to optimize time and efficiency (SkyDuo Kit available as optional accessory).
- GreaseOut: predisposed for integrated grease drain and collection for safer operations (dedicated base as optional accessory).
- USB port: to download HACCP data, share cooking programs and configurations. USB port also allows to plug-in sous-vide probe (optional accessory).
- Connectivity: ready for real time access to connected appliances from remote and HACCP monitoring (requires optional accessory).
- e-learning: equipment trainings, how-to guides, and technical documentation easily accessible by scanning QR-Code with any mobile device.
- Back-up mode: self-diagnosis is automatically activated if a failure occurs to avoid downtime.
- Data Analytics: automatic consumption visualization at the end of the cycle.

Construction

- Human centered design: with 4-star certification for ergonomics and usability.
- Door handle: ergonomic wing-shaped design for hands-free door opening with elbow, to allow simple trays management (Registered Design at EPO).
- Triple thermo-glazed door: with 2 hinged inside panels for easy cleaning and double LED lights line.
- Seamless hygienic internal chamber with all rounded corners for easy cleaning.
- 304 AISI stainless steel construction throughout.
- Front access to control board for easy service.
- Integrated spray gun with automatic retracting system for fast rinsing.
- IPX 5 spray water protection certification for easy cleaning.

- Supplied with 6 tray rack for full size pans, 2 2/3" pitch.

Included Accessories

- 3 of Aisi 304 stainless steel grid (18" x 26") PNC 922076

Optional Accessories

- Chicken racks, pair (2) (fits 8 chickens per rack) PNC 922036
- Single 304 stainless steel grid (12" x 20") PNC 922062
- Aisi 304 stainless steel grid (18" x 26") PNC 922076
- External side spray unit PNC 922171
- Pair of frying baskets PNC 922239
- Double-click closing catch for oven door PNC 922265
- Grid for whole chicken 1/1GN (8 per grid - 1,2kg each) PNC 922266
- USB Probe for sous-vide cooking (only for Touchline ovens) PNC 922281
- Kit universal skewer rack & (6) long skewer ovens (TANDOOR) PNC 922325
- Universal skewer pan for ovens (TANDOOR) PNC 922326
- Skewers for ovens, (6) 14" short (TANDOOR) PNC 922328
- Smoker for ovens PNC 922338
- Multipurpose hook PNC 922348
- 4 FLANGED FEET FOR 61,62,101,102 OVENS - 2" 100-130MM PNC 922351
- Grease collection tray (2 2/5") for 62 and 102 ovens PNC 922357
- GRID FOR 8 WHOLE DUCKS (1.8KG, 4LBS) - GN 1/1 PNC 922362
- HOLDER FOR DETERGENT TANK - WALL MOUNTED PNC 922386
- Slide-in rack with handle for 62, and 102 combi oven PNC 922605
- Tray rack with wheels, 62 combi oven, h=80mm (3 1/6") PNC 922611
- Open base with tray support for 62 & 102 combi oven PNC 922613
- Cupboard base with tray support for 62 & 102 combi oven PNC 922616
- External connection kit for detergent and rinse aid PNC 922618
- Stacking kit for gas 62/62 combi ovens PNC 922624
- Stacking kit for gas 62 combi oven placed on 102 gas combi oven PNC 922625
- Trolley for slide-in rack for 102 oven and blast chiller freezer PNC 922627
- Trolley for mobile rack for 2 stacked 62 combi ovens on riser PNC 922629
- Trolley for mobile rack for 62 on 62 or 102 combi ovens PNC 922631
- Riser on feet for 2 stacked 61 combi ovens PNC 922633
- Riser on wheels for 2 stacked 62 combi ovens, height=250mm (9 6/7in) PNC 922634
- Stainless steel drain kit for 61, 62 & 101, 102 combi oven, d=50mm (2") PNC 922636
- Plastic drain kit for 61, 62 & 101, 102 combi oven, dia=50mm (2") PNC 922637
- Trolley with 2 tanks for grease collection PNC 922638

- Grease collection kit for open base (trolley PNC 922639 with 2 tanks, open/close device and drain)
- Wall support for 62 oven PNC 922644
- Dehydration tray, (12" x 20"), H=2/3" PNC 922651
- Flat dehydration tray, (12" x 20") PNC 922652
- Heat shield for 62 combi oven PNC 922665
- Heat shield for stacked ovens 62 on 62 combi ovens PNC 922666
- Heat shield for stacked ovens 62 on 102 combi ovens PNC 922667
- Kit to convert from natural gas to LPG PNC 922670
- Kit to convert from LPG to natural gas PNC 922671
- Fixed tray rack, 62 combi oven, h=h=85mm (3 1/3") PNC 922681
- Kit to fix oven to the wall PNC 922687
- Tray support for 62 & 102 open base PNC 922692
- 4 adjustable feet with black cover for 61,62 & 101,102 combi ovens, 150-200mm (5 9/10in - 7 9/16in) PNC 922693
- Detergent tank holder for open base PNC 922699
- Tray rack with wheels, 62 combi oven, h=65mm (2 1/2") PNC 922700
- Probe holder for liquids PNC 922714
- 4 high adjustable feet for 61,62 & 101,102 combi ovens, 230-290mm (9in - 11 2/5in) PNC 922745
- Tray for traditional static cooking, H=100mm (12" x 20") PNC 922746
- Double-face griddle, one side ribbed and one side smooth, 400x600mm PNC 922747
- Non-stick universal pan 12" x 20" x 3/4" PNC 925000
- Non-stick universal pan 12" x 20" x 1 1/2" PNC 925001
- Non-stick universal pan 12" x 20" x 2 1/2" PNC 925002
- Frying griddle double sided (ribbed/smooth) 12" x 20" PNC 925003
- Egg fryer for 8 eggs 12"X20" PNC 925005
- Flat baking tray with 2 edges 12" x 20" PNC 925006
- Potato baker GN 1/1 for 28 potatoes (12"X20") PNC 925008
- WOOD CHIPS OAK - 450GR PNC 930209
- WOOD CHIPS HICKORY - 450GR PNC 930210
- WOOD CHIPS MAPLE - 450GR PNC 930211
- WOOD CHIPS CHERRY - 450GR PNC 930212
- Compatibility kit for installation on previous base 62,102 PNC 930218

Front

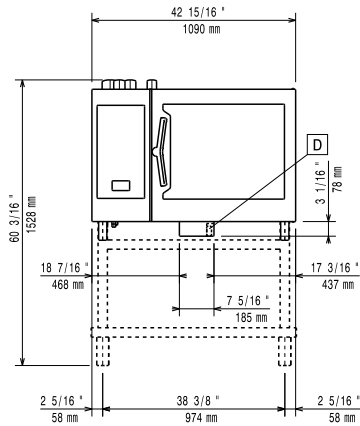

Side

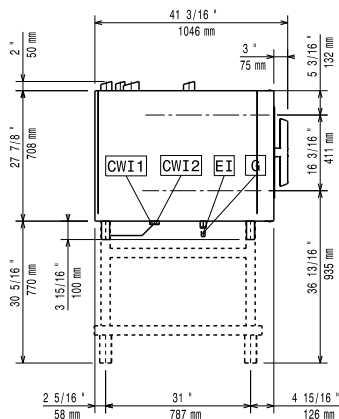

CWI1 = Cold Water inlet EI = Electrical connection

CWI2 = Cold Water Inlet 2 G = Gas connection

D = Drain

DO = Overflow drain pipe

Top

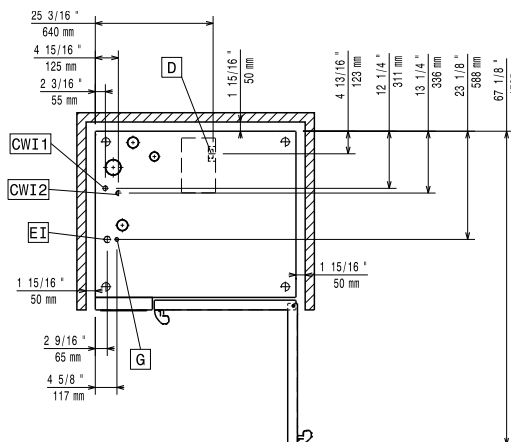

Electric

| | | |
|-----------------------------------|--------------------|------------------|
| Supply voltage: | 219781 (ECO62T300) | 120 V/1 ph/60 Hz |
| Electrical power, default: | | 1.5 kW |
| Circuit breaker required | | |
| Current consumption: | | 12.5 Amps |

Gas

| | |
|---|------------------------|
| Gas Power: | 37.7 kW |
| Standard gas delivery: | Natural Gas G20 |
| ISO 7/1 gas connection diameter: | 1/2" MNPT |
| LPG: | |
| Total thermal load: | 128519.3 BTU (37.7 kW) |

Water:

| | |
|--|-----------------------|
| Water inlet "FCW" connection: | 3/4" |
| Pressure: | 15-65 psi (1-4.5 bar) |
| Drain "D": | 2" (50 mm) |
| Max inlet water supply temperature: | 86°F (30°C) |
| Conductivity: | >285 µS/cm |
| Water drain outlet: | 1 15/16" (50mm) |
| Water inlet cold 1: | 3/4" |
| Water inlet cold 2: | 1/2" |

Electrolux recommends the use of treated water, based on testing of specific water conditions.
Please refer to user manual for detailed water quality information.

Installation:

| | |
|--|---|
| Clearance: | Clearance: 2 in (5 cm) rear and right hand sides. |
| Suggested clearance for service access: | 20 in (50 cm) left hand side. |

Capacity:

| | |
|------------------------------|--------------------|
| GN: | 6 - 2/1 Gastronorm |
| Max load capacity: | 132 lbs (60 kg) |
| Full-size sheet pans: | 6 - 18" X 26" |

Key Information:

| | |
|-------------------------------------|---------------------|
| Door hinges: | Right Side |
| External dimensions, Width: | 42 15/16" (1090 mm) |
| External dimensions, Depth: | 38 1/4" (971 mm) |
| External dimensions, Height: | 31 13/16" (808 mm) |
| Net weight: | 360 lbs (163.5 kg) |