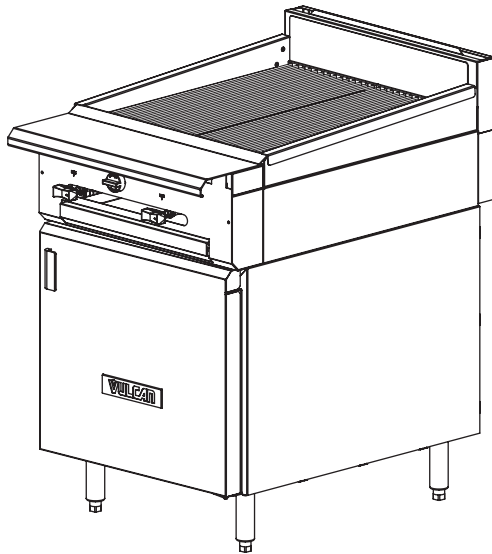

**HEAVY DUTY COOKING****VULCAN****HEAVY DUTY GAS RANGE  
24" WIDE INFRARED CHARBROILER GAS RANGE**

**Model VTC24B**  
(shown on cabinet base)

**SPECIFICATIONS**

High efficiency gas infrared charbroiler, Vulcan Model No. VTC24 (modular) or VTC24B (cabinet base). Stainless steel front, plate ledge, front top ledge with pull-out condiment rails, sides, base, stub back and 6" adjustable legs. 1 1/4" diameter front gas manifold. Full width, stainless steel crumb tray. Heavy duty, steel infrared emitter panels. 11" x 25" stainless steel cooking grids. One 22,000 BTU/hr. patented infrared burner system for each cooking grid. Direct ignition piezo spark igniters. One high range heat control valve for each burner. Chrome burner knobs. 4" adjustable legs. 1/4" NPT rear gas connection. Total input 44,000 BTU/hr.

**Exterior Dimensions:**

36 3/4" d x 24" w x 36" h on 6" adjustable legs

- VTC24** 24" Infrared Charbroiler / Modular
- VTC24B** 24" Infrared Charbroiler / Cabinet Base

**STANDARD FEATURES**

- Stainless steel front, front top ledge, burner box, sides, base, and stub back
- 1 1/4" diameter front gas manifold with 1 1/4" rear gas connection (capped)
- Heavy duty steel infrared emitter panels
- Energy efficient 22,000 BTU/hr., patented infrared burner system in each cooking zone
- Direct ignition piezo spark igniters
- One high range heat control valve for each burner
- Chrome burner control knobs
- 4" stainless steel stub riser
- 6" adjustable stainless steel legs for "B" models.
- Stainless steel cabinet base door
- Universal rack guides, with one removable shelf (cabinet base)
- One year limited parts and labor warranty

**OPTIONAL FEATURES (Factory Installed)**

- Cap and cover front manifold
- 4" adjustable flanged feet for modular models
- Less legs for dolly mounting of cabinet base models
- 3" high toe base for curb mounting for "S", "C", & "B" models

**ACCESSORIES (Packaged & Sold Separately)**

- 3/4", 1", or 1 1/4" gas pressure regulator (specify gas type – pack loose)
- Set of 4 casters, 6" high (two locking)
- 6" adjustable flanged feet for cabinet base models
- Extra removable shelves for use with Universal rack guides (cabinet base)
- Banking strip
- 10", 22", or 34" high back risers (no shelf)
- 22" single deck solid or flo-thru high shelf risers
- 34" double deck solid or flo-thru high shelf risers
- Flexible gas hose with quick disconnect and restraining device
- Common condiment type, telescoping plate rail (starting at 24" length)

**VULCAN**

a division of ITW Food Equipment Group LLC

P.O. Box 696 ■ Louisville, KY 40201 ■ Toll-free: 1-800-814-2028 ■ Local: 502-778-2791 ■ Quote & Order Fax: 1-800-444-0602



## HEAVY DUTY GAS RANGE 24" WIDE INFRARED CHARBROILER GAS RANGE

### INSTALLATION INSTRUCTIONS

1. A properly sized gas pressure regulator suitable for battery or single unit application must be furnished and installed. Natural gas 6.0" W.C., propane gas 10.0" W.C.
  2. An adequate ventilation system is required for commercial cooking equipment. Information may be obtained by writing to the National Fire Protection Association, 1 Batterymarch Park, Quincy, MA 02269, www.NFPA.org. When writing, refer to NFPA No. 96.
  3. These units are manufactured for installation in accordance with ANSZ223.1A (latest edition), National Fuel Gas Code. Copies may be obtained from The American Gas Association, 400 N Capitol St. NW, Washington, DC 20001, www.AGA.org.
  4. **Clearances**  

	Rear	Sides
Combustible	10"	10"
Non-combustible	0"	0"
  5. For proper combustion, install equipment on adjustable legs or casters. On curb or platform, allow 3½" front overhang. Toe base with leveling bolts are required for curb installation. Specify when ordering.
  6. Cannot be battered with GH series equipment.
  7. This appliance is manufactured for commercial installation only and is not intended for home use.
- NOTE:** In line with its policy to continually improve its product, Vulcan reserves the right to change materials and specifications without notice.

**Specify type of gas when ordering.  
Specify altitude when above 2,000 feet.**

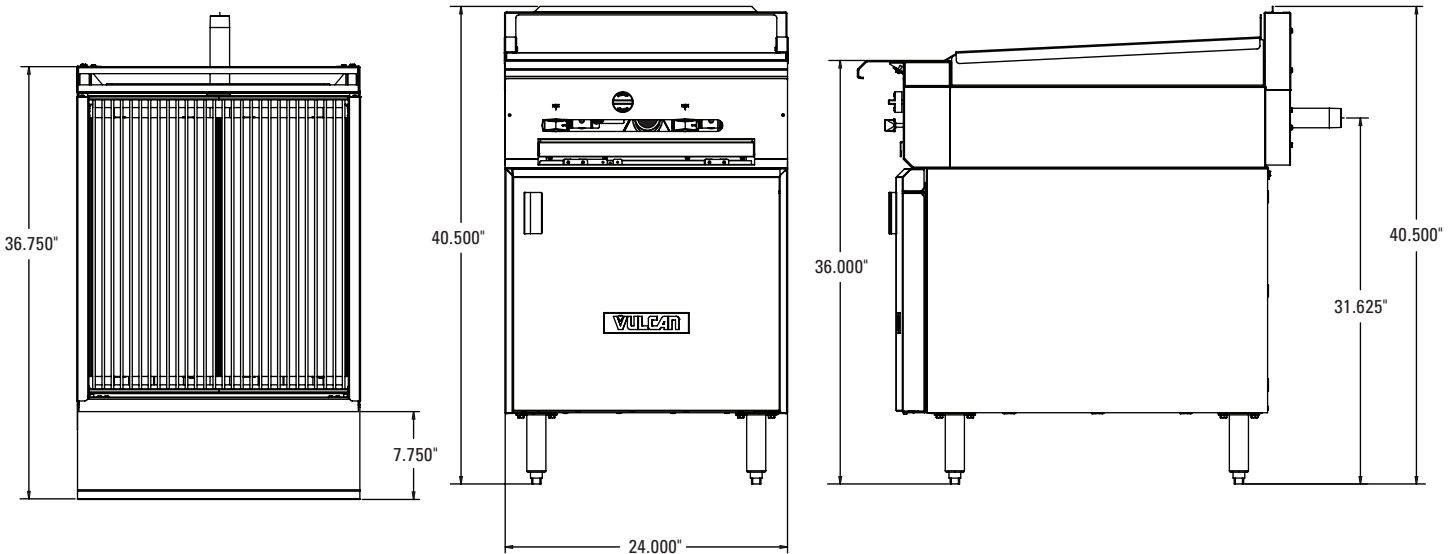

TOP CONFIGURATION	MODEL NUMBER	DESCRIPTION	TOTAL INPUT BTU / HR	SHIPPING WEIGHT LBS / KG
	VTC24	24" Infrared Charbroiler / Modular	44,000	305 / 139
	VTC24B	24" Infrared Charbroiler / Cabinet Base	44,000	405 / 184



a division of ITW Food Equipment Group LLC

P.O. Box 696 ■ Louisville, KY 40201 ■ Toll-free: 1-800-814-2028 ■ Local: 502-778-2791 ■ Quote & Order Fax: 1-800-444-0602

**NOTE:** In line with its policy to continually improve its products, Vulcan reserves the right to change materials and specifications without notice.