



---

# AC-2

---

## Air Curtain Display Cooler

# KEY ASPECTS

## SPECIAL FEATURES:

- GFCI power cord
- Electronic thermostat
- Energy efficient
- Adjustable shelf
- Innovation in small footprinting open cooler technology
- High impulse beverage refrigeration

## OPTIONS:

- Graphics
- Casters with 2 locking



Complies with 2017 DOE standards for commercial cooler without door

## TECHNICAL SUMMARY

MODEL	SIZE				ELECTRICAL	REFRIGERATION			OTHER			
	Dimensions (inches)* Width x Depth ***x Height	Cubic Feet	Net Weight (lbs.)	Shipping Weight (lbs.)**	Voltage/Hz/Phase	Running Amps	Compressor HP	Refrigerant	Temperature	No. of 8.4 oz cans	No. of 12 oz cans	No. of 16.9 oz bottles Container Quantity
AC-2	25 7/8 x 16 5/8 x 36	2.4	101	116	115/60/1	2.7	1/4	R-134a	+32°F to +41°F	89	54	40 138

\*Dimensions are all nominal lengths

\*\*Does not include weight of pallet when needed

\*\*\*Does not include back spacer

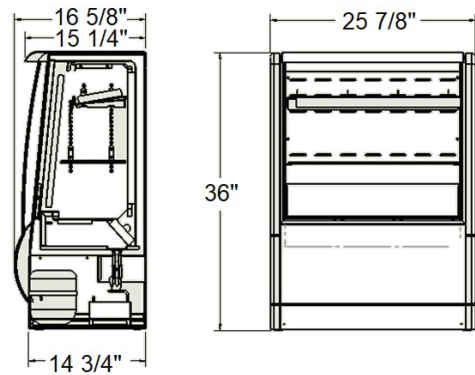

500 S. Falkenburg Road  
Suite 200 | Tampa, FL 33619  
800.441.4014 | 813.870.0340  
www.excellenceindustries.com  
ver. 5.19