



Simply Engineered Better

Project \_\_\_\_\_

Item No. \_\_\_\_\_

Quantity \_\_\_\_\_

601HRG HEAT RECOVERY GLASSWASHER

# 601HRG

Undercounter Heat Recovery  
Glasswasher with Built-in Booster



## STANDARD FEATURES

- **Heat recovery: Cold water feed only!**
- **Up to 50% more energy efficient!**
- **Quicker drying of wares!**
- **Condensation is removed!**
- **Reduced operation costs!**
- **RAPID-DRY** provides improved and quicker drying of glassware
- **Ergonomical, practical, 22-1/2" [572]** loading height
- **Soft Start**, protects glasses and mugs from chipping and breaking
- **Industry leading**, deep drawn, type 316 stainless steel tank
- **12-1/8" [308] door opening**, ideal for racked glasses
- **Multi-cycle**; 3 cycle time options for enhanced cleaning
- Delime feature allows easy delimiting of wash cavity
- Auto-clean flushes tank interior at end of serving period
- Electric tank heater ( 2 kW )
- Microcomputer controls and digital temperature displays
- Standard pumped drain for total ease of installation
- Liquid detergent and rinse-aid dispensing pumps complete with prime switches

## SPECIFIER STATEMENT

Specified unit will be the Moyer Diebel model 601HRG undercounter heat recovery glasswasher with built-in booster operating on a 1/2" cold water supply only.

Features include 37-1/4" height, 12-1/8" door opening, selectable 120,200 and 277 second cycle times, built-in 5kW booster, 2 kW tank heater, LED temperature display, Rinse Sentry, rinse aid and detergent pumps, flexible fill and drain hoses as well as an auto-clean cycle which flushes tank interior at shutdown. Unit shall incorporate a RAPID DRY feature to improve and quicken the drying of wares. Wash tank constructed of type 316 stainless steel.

1 year parts and labor warranty.

## OPTIONS & ACCESSORIES

- |                          |   |               |
|--------------------------|---|---------------|
| <input type="checkbox"/> | 3 Phase Connection (prewired at factory)            | -             |
| <input type="checkbox"/> | Drain Water Tempering Kit (factory installed)       | P/N 0713725   |
| <input type="checkbox"/> | Low Chemical Alarm                                  | P/N 0712314-2 |
| <input type="checkbox"/> | Power Cord Kit                                      | P/N 0713741   |
| <input type="checkbox"/> | 17RS – 17" Stand (replaces existing stand)          | P/N 0708757   |
| <input type="checkbox"/> | 4" Stand<br>(converts to a standard counter height) | P/N 0714292   |
| <input type="checkbox"/> | 1" Roller kit (adds 1" to height)                   | P/N 0712480-1 |
| <input type="checkbox"/> | Flat bottom dishrack                                | P/N 101273    |
| <input type="checkbox"/> | Peg dishrack  | P/N 101285    |

MD601HRG Printed in U.S.A.



### Moyer Diebel – USA

3765 Champion Blvd., Winston-Salem, NC 27105 Tel: 336/661-1992 Fax: 336/661-1979 800/228-8350

sales@moyerdiebel.com

www.moyerdiebel.com



Simply Engineered Better

# 601HRG

Undercounter Heat Recovery  
Glasswasher with Built-in Booster

Dimensions shown in inches and [millimeters]

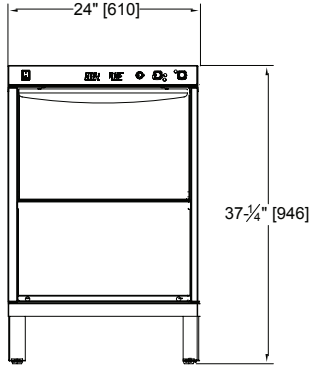

Front View

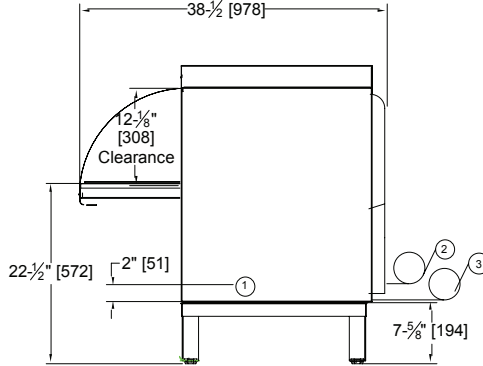

Side View

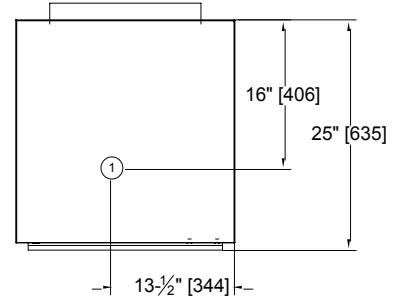

Plan View

## SPECIFICATIONS

|   |            |
|---|------------|
| <b>Capacity</b>                         |            |
| *Racks per hr.                          | 25         |
| <b>Motor Horsepower</b>                 |            |
| Wash                                    | 1          |
| <b>Water Consumption</b>                |            |
| US gal per hr. (max. use)               | 15.6       |
| US gal per rack                         | 0.65       |
| <b>Temperatures °F</b>                  |            |
| Wash (minimum)                          | 150        |
| Rinse (minimum)                         | 180        |
| <b>Heating</b>                          |            |
| Tank heat, electric (kW)                | 2          |
| Electric booster                        | 5          |
| <b>Time Cycle in Seconds</b>            |            |
| Wash                                    | 45/120/197 |
| Rinse                                   | 13         |
| Heat recovery/condense                  | 62         |
| <b>Standard 20"x20" Rack Complement</b> |            |
| Dish                                    | 1          |
| Open                                    | 1          |

\* Excludes 30 second NSF load/unload time

**Warning:** Plumbing and electrical connections should be made by qualified personnel who will observe all the applicable plumbing, sanitary and safety codes.

Due to an ongoing value analysis program at Moyer Diebel, specifications in this catalog are subject to change without notice.

Moyer Diebel – USA  
3765 Champion Blvd., NC 27105  
336/661-1992 • Fax: 336/661-1979

moyerdiebel.com

## Utilities

|                                |   |
|--------------------------------|---|
| <b>1 Electrical Connection</b> | 208-240/60/1; 3 wire plus ground. (see box)<br>208-240/60/3; 4 wire plus ground.<br>Field convertible to accept 3 phase power, see service manual for details |
| <b>2 Cold Water</b>            | 1/2 supply; 55-80°F cold water; 25 PSI min.<br>Machine equipped with 3/4" hose connector  |
| <b>3 Pumped Drain</b>          | 5/8" I.D. flexible reinforced hose, 6ft. long.<br>Max. drain flow 15 US gpm. Max drain height 3ft.  |

## 601HRG with Booster

| Electrical Specs. | Rated Amps | Minimum Supply Ckt. Conductor Ampacity | Maximum Overcurrent Protective Device |
|-------------------|------------|--|---------------------------------------|
| 208/60/1          | 32         | 40                                     | 40                                    |
| 240/60/1          | 36         | 40                                     | 40                                    |
| 208/60/3          | 22         | 30                                     | 30                                    |
| 240/60/3          | 24         | 30                                     | 30                                    |

Field convertible to accept 3 phase power.

