

model no:

SG140D, SG140P,
SG145D, SG145P



SIGNATURE SERIES

WABASH VALLEY

46" SQUARE & OCTAGON TABLE
PORTABLE – EXPANDED METAL & PERFORATED

© Wabash Valley Manufacturing, Inc.

customer service:

ASSEMBLERS: If you find any parts missing or damaged, or if you're having difficulty assembling your furniture/equipment, call us at:

* Before calling, have your product model number available.

1-800-253-8619 (Inside U.S.A.)
260-352-2102 (Outside U.S.A.)
Monday thru Friday,
8:00 AM – 4:30 PM Eastern Time
(EXCEPT HOLIDAYS)

Any correspondence concerning our product should be sent directly to our Customer Service Manager at:

Wabash Valley Manufacturing, Inc.
505 E. Main Street
P.O.Box 5
Silver Lake, IN 46982 U.S.A.
FAX: 260-352-2160

maintenance:

Regular inspection and maintenance of all parts, and fasteners is necessary. Tighten all bolts and nuts. Inspect Tops, Seats, Legs, Braces and Fasteners periodically for wear or vandalism. Replace broken or worn parts immediately or take equipment out of service until repairs are made. Use genuine Wabash Valley replacement parts.

To restore plastisol coating to its luster after prolonged use, wash/rinse/dry and use Armor-All ® or similiar quality vinyl protectant.

KEEP THIS ASSEMBLY/SPECIFICATION SHEET FOR FUTURE REFERENCE.

specifications:

NOTE: We reserve the right to change specifications without notice.

Heat fused poly-vinyl coating, finished on inner-metal structure, to an approximate 3/16" thickness. Framework assemblies are finished with powder coating; electrostatically applied and oven cured according to powder manufacturer's specifications. Fasteners are stainless steel to resist corrosion.

TABLE FRAME:

Main supports are constructed of 1 5/8" od x 14 gage galvanized structural steel tubing. Cross brace is 1" od x 15 gage galvanized structural steel tubing. Mounting brackets on legs are 1/4" x 1 1/4" flat bar steel.

TOP & SEATS:

Top and seats use fabricated 3/4" #9 expanded steel mesh. Perforated is made from 12 gage sheet steel. Framing consists of die-formed 14 gage mitered angles 3/4" x 1 3/4". Top and seat mounting brackets are 1/4" x 1 1/2" flat bar steel. Tops corner support braces are 1/8" x 1 1/2" strip steel.

GENERAL:

46" square table ground space requirements are 74 3/8" squared. Table top is 46 3/8" square and 29 1/4" to top of table. Seats are 10 3/8" wide x 36 3/8" long and 19 5/8" to top of seat. Corner radius is 3" on the outside.

NOTE: When Umbrellas are used on Tables, the Umbrellas must be secured.
Wabash Valley Umbrellas include an Umbrella Collar for securing.

parts identification:

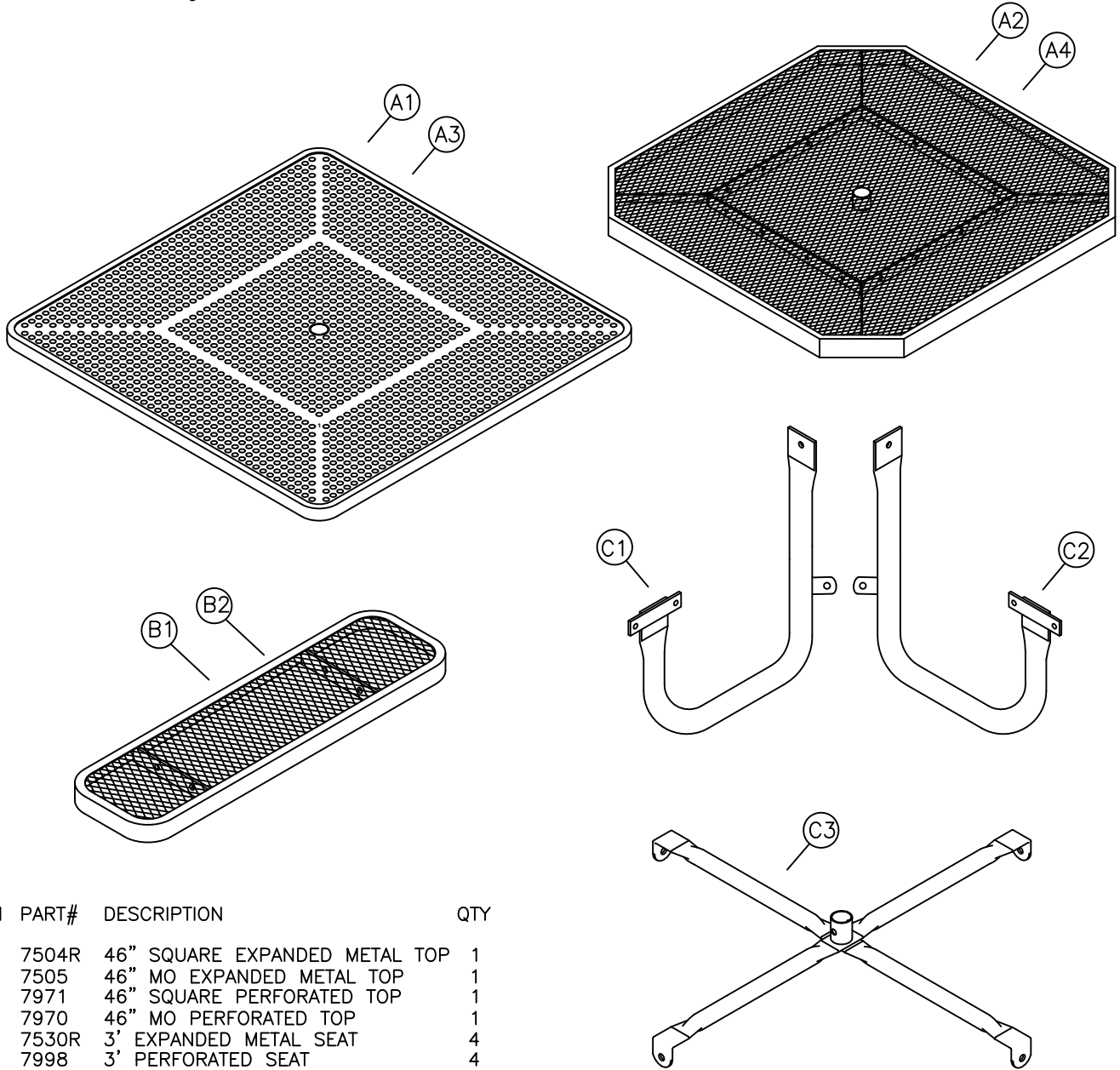

ITEM	PART#	DESCRIPTION	QTY
A1	7504R	46" SQUARE EXPANDED METAL TOP	1
A2	7505	46" MO EXPANDED METAL TOP	1
A3	7971	46" SQUARE PERFORATED TOP	1
A4	7970	46" MO PERFORATED TOP	1
B1	7530R	3' EXPANDED METAL SEAT	4
B2	7998	3' PERFORATED SEAT	4
C1	7326	46" LEG - RIGHT	4
C2	7327	46" LEG - LEFT	4
C3	7381	46" CROSS BRACE	1

hardware identification:

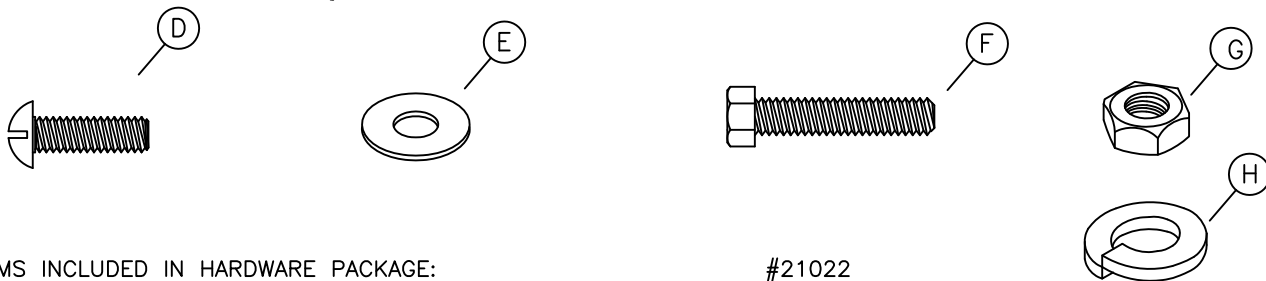

ITEMS INCLUDED IN HARDWARE PACKAGE:

#21022

ITEM	PART #	DESCRIPTION	QTY
D	17088	5/16-18 X 1" TRUSS HEAD MACHINE SCREW - SS	4
E	17028	3/8" ID x 7/8" OD FLAT WASHER - SS	56
F	17011	5/16-18 x 1 1/2" HEX HEAD BOLT - SS	24
G	17032	5/16-18 HEX FINISH NUT - SS	28
H	17050	5/16" SPLIT LOCK WASHER - SS	28

TOOLS REQUIRED FOR ASSEMBLY

- 1 - REGULAR TIP SCREW DRIVER
- 2 - 1/2" WRENCHES
- 1 - 3' OR 6' LEVEL

assembly procedures:

IMPORTANT: Assemblers should be reasonably skilled in the assembly of commercial grade/heavy duty fabricated steel equipment.

To ensure proper assembly, it is suggested that you take adequate time to locate and identify each part. To prevent scratching of the finished pieces, we recommend this unit to be assembled on a clean, flat, solid, surface with a drop cloth, allowing plenty of working room. Also please read the instructions and study the sketches very carefully. A little extra time spent before assembly will be well worth it in performing a complete, proper assembly. Please note that all parts have been pre-cut and pre-drilled.

During the assembly process leave all bolts and nuts "finger tight", until the entire unit is completely assembled. This allows room for movement to level or adjust all seats, tops, benches, framework and braces if necessary. After final adjustment and leveling, permanently tighten all nuts, bolts and fasteners.

7L

STEP 1

Invert the (A-) top so it's upside down on a flat surface. Attach a left and right leg (C1 and C2) to an outside corner of the top's center square mounting frame, see FIG. 1. Secure the top end of each leg to the outside of the top's center square mounting frame, using one, per each leg, (F) and (G), using two (E) and one (H) per each (F).

NOTE: The cross brace tab on each leg, should meet each other at every corner when assembling the legs. Temporarily insert one (D), (G), (H) and (E) loosely into the cross brace tab hole of each leg. This allows the legs to secure and hold each other in place at each corner.

Repeat step 1, until each leg is properly attached at all four corners of the square top.

STEP 2

Attach all four ends of the (C3) cross brace, where four corners of the cross brace tabs of each leg meet, using the bolts you temporarily secured to hold each leg together, see FIG. 2.

NOTE: Before attaching the cross brace, make sure the round cylinder at the center of the cross brace is pointing down toward the bottom side of the top.

STEP 3

Check all fasteners making sure each fastener is finger tight and properly supporting the unit. Re-invert the table to its top side up position.

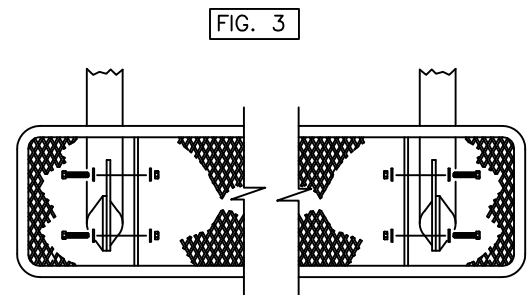
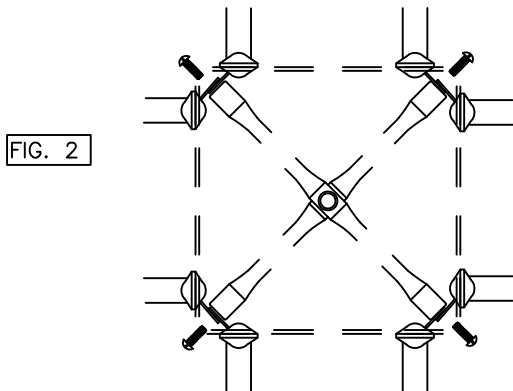
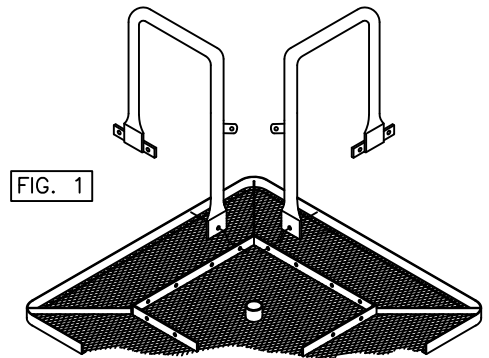

STEP 4

Attach each (B) seat to the seat end of each leg, making sure the seat's mounting brackets fit to the outside of the leg's end seat mounting brackets, see FIG. 3. Secure the seats using two, per each mounting bracket, (F) and (G), using two (E) and one (H) per each (F).

STEP 5

Level seats and top if necessary. Tighten all fasteners with wrenches.

installation:

WARNING: The proper installation for Wabash Valley products may depend upon many factors unique to the site, location, or use of a particular product. Consult with your contractor or other professional to determine your specific installation requirements.

product dimensions:

SG140D/SG140P

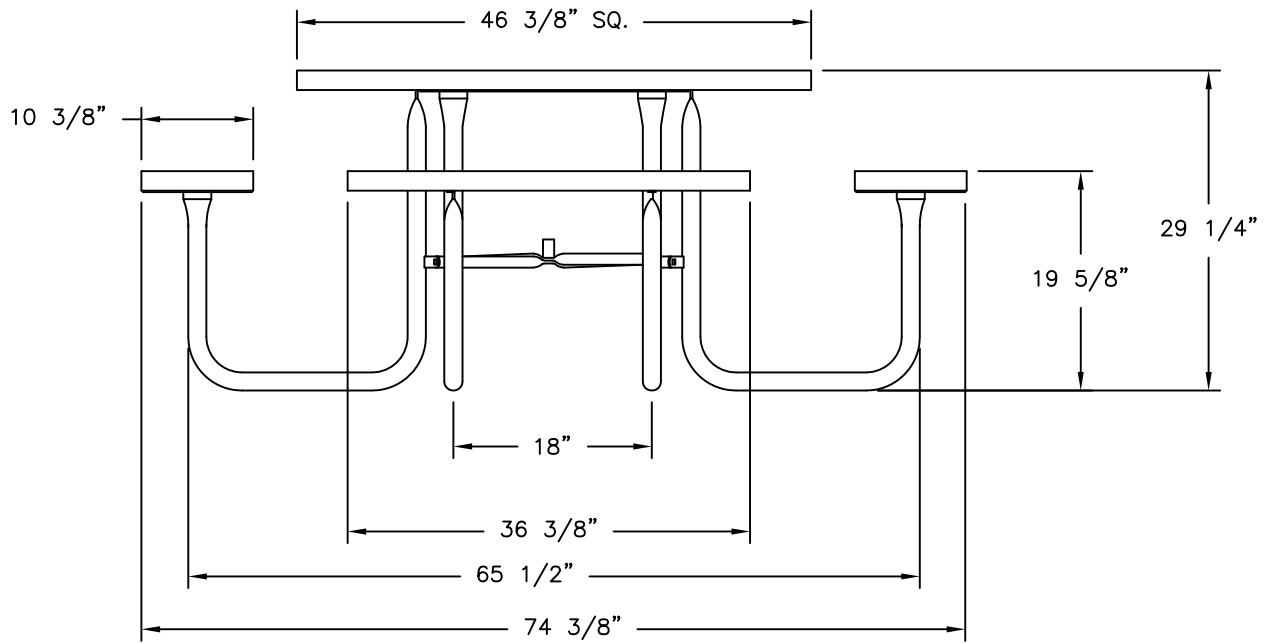

SG145D/SG145P

