



**John
BOOS**
Since 1887

ITEM #: _____ QTY: _____
 MODEL #: _____
 PROJECT NAME: _____

070919

3601 S. Banker St. Effingham, IL 62401 • P.O. BOX 609 • Ph: (888) 431-2667 • Fax: (800) 433-2667

"EES8-SSK" EQUIPMENT STAND **STAINLESS STEEL BASE**



FEATURES:

- 18GA TYPE 430 STAINLESS STEEL TOP WITH #4 POLISH, SATIN FINISH
- 1-1/2" STALLION EDGE ON FRONT. TURNED UP BACK AND BOTH SIDES
- TOP FRAME IS REINFORCED BY A FULL FRAME FABRICATED OF 1-1/2" SQUARE O.D. TUBE 16GA STAINLESS STEEL
- GALVANIZED STEEL BASE
- SHIPPED KNOCKED-DOWN, EASY - TO - ASSEMBLE

CONSTRUCTION:

- TOP: STAINLESS STEEL TOPS ARE TIG WELDED, EXPOSED WELDS ARE POLISHED TO MATCH ADJACENT SURFACE

MATERIAL:

- TOP: 18GA STAINLESS STEEL TYPE 430 STAINLESS STEEL WITH #4 POLISH, SATIN FINISH
- SHELF: 18GA STAINLESS STEEL
- LEGS: 1-5/8" ROUND O.D. 16 GA TUBULAR STAINLESS STEEL
- GUSSETS: STAINLESS STEEL
- FEET: 1" ADJUSTABLE PLASTIC BULLET FEET



EES8-3048SSK

ECONOMY EQUIPMENT STANDS WITH STAINLESS STEEL BASE

MODEL #	QTY
EES8-3015SSK	
EES8-3018SSK	
EES8-3024SSK	
EES8-3036SSK	
EES8-3048SSK	
EES8-3060SSK	
EES8-3072SSK	

DETAILED SPECIFICATIONS

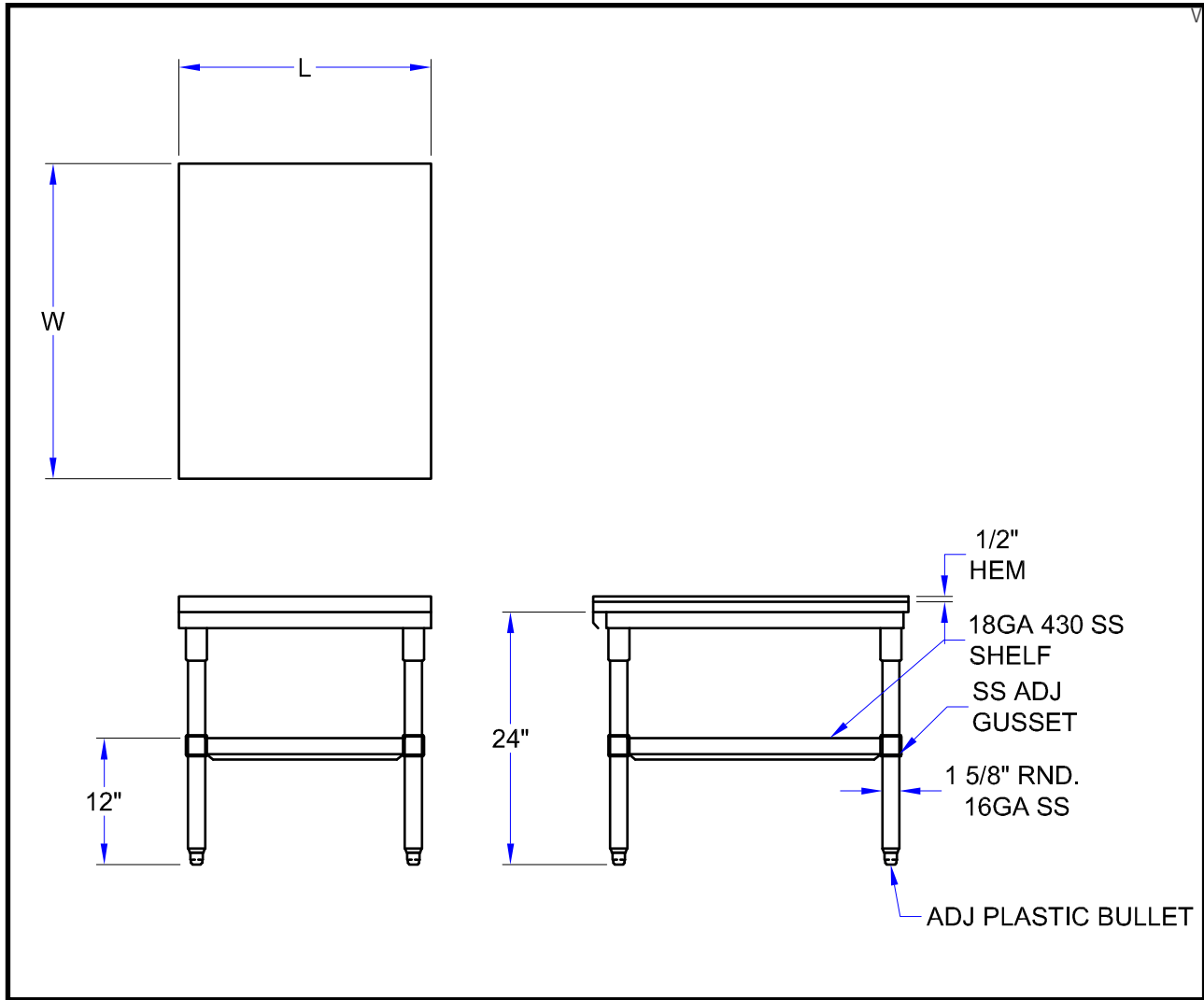

ECONOMY EQUIPMENT STANDS WITH GALVANIZED BASE

MODEL #	LENGTH	WIDTH	HEIGHT	WT. (LBS)
EES8-3015SSK	15"	30"	24"	25
EES8-3018SSK	18"	30"	24"	29
EES8-3024SSK	24"	30"	24"	38
EES8-3036SSK	36"	30"	24"	56
EES8-3048SSK	48"	30"	24"	69
EES8-3060SSK	60"	30"	24"	82
EES8-3072SSK	72"	30"	24"	94

WEIGHTS ARE SUBJECT TO ADDITIONAL PACKAGING

SOME UNITS SHIP UNASSEMBLED FOR REDUCED SHIPPING COST. ALL DIMENSIONS ARE TYPICAL. TOLERANCE +/- .500"
 John Boos & Co. is constantly engaged in a program of improving products and therefore reserves the right to change specifications without prior notice.



Boos
lock

AQ AutoQuotes

3601 S. Banker St. • Effingham, IL 62401 • PO BOX 609 • quotes@johnboos.com

www.johnboos.com

070119

109