

HOBART701 S Ridge Avenue, Troy, OH 45374
1-888-4HOBART • www.hobartcorp.com**FOOD MACHINE
ACCESSORY TABLES****HOBART****STANDARD FEATURES**

- Heavy gauge stainless steel tops, legs, and shelves
- Models 205024-1, 205025, and 205026 have chrome plated adjustable leveling feet
- Model 124078 has four locking casters

ACCESSORIES

- Large, heavy duty casters (PN 205028) (casters are included on Model 124078)

SOLUTIONS / BENEFITS

Heavy Gauge Stainless Steel Tops, Legs, and Shelves

- **Durability**
Built to support rugged cutting or mixing operation
- **Sanitation**
Heavy gauge stainless steel
Stability with chrome plated adjustable leveling feet
- **Flexibility, ease of mobility**
Four locking casters
Available on Models 205024-1, 205025 and 205026
- Included on Model 124078
- Available as an option for other models
- Casters add six inches to height of table

Specifications, Details and Dimensions on Reverse Side.

**MODELS**

- Model 124078 A-120 and A-200 Mixer Table**
Single Shelf Model
27 x 32 inches x 26¾" inches high
Includes 4 locking casters, mounting holes for mixer, 4 pegs for storage of beaters, whips, dough arms, etc.
- Model 205024-1 Mixer Table**
Single Shelf Model
20 x 24 inches x 22 inches high
Ideal for use with Hobart 5, 10, 12, and 20 quart mixers
- Model 205025 Food Cutter Table**
Single Shelf Model
- Model 205026 Food Cutter Table**
Double Shelf Model
27 x 32 inches x 31⅞ inches high
Accommodates either the 84145 or 84186 Hobart Food Cutter

**FOOD MACHINE ACCESSORY TABLES**

FOOD MACHINE ACCESSORY TABLES



701 S Ridge Avenue, Troy, OH 45374
1-888-4HOBART • www.hobartcorp.com

LISTED BY: UNDERWRITERS LABORATORIES & NATIONAL SANITATION FOUNDATION AND USDA

DETAILS AND DIMENSIONS

MIXER TABLES

MODEL 205024-1

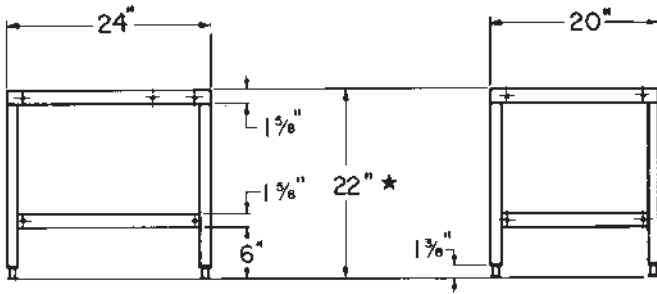

MODEL 124078

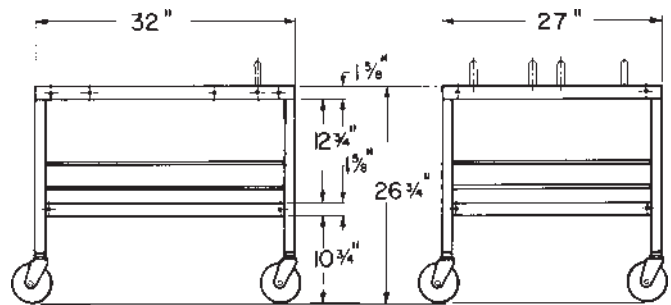

FOOD CUTTER TABLES

MODEL 205025

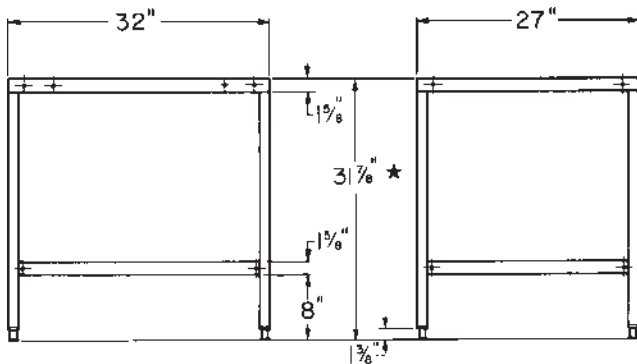

MODEL 205026

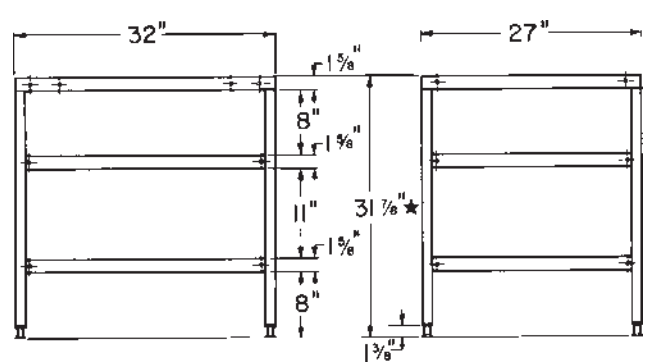

* Add 6" to height when ordering tables with casters.

As continued product improvement is a policy of Hobart, specifications are subject to change without notice.