



ITEM #: \_\_\_\_\_ QTY: \_\_\_\_\_  
 MODEL #: \_\_\_\_\_  
 PROJECT NAME: \_\_\_\_\_

070517

3601 S. Banker St. Effingham, IL 62401 • P.O. BOX 609 • Ph: (888) 431-2667 • Fax: (800) 433-2667

**"FTSG" FLOOR TROUGHS - STAINLESS STEEL 14GA**  
**4" DEEP W/ SUBWAY-STYLE STAINLESS STEEL GRATING AND**  
**REMOVABLE PERFORATED STRAINED**

**FEATURES:**

- ACCOMODATES A 4" O.D. DIAMETER DRAIN PIPE 3.25" LONG
- REMOVABLE GRATE WITH 1/8" STAINLESS STEEL BARS ON 3/4" CENTERS
- 5 DEGREE BREAKS IN BOTTOM FOR POSITIVE DRAINAGE TOWARDS DRAIN
- INCLUDES DRAINAGE GRATE WITH 1/4" HOLES

**CONSTRUCTION:**

- ALL TIG WELDED, EXPOSED WELDS ARE POLISHED TO MATCH ADJACENT SURFACE

**MATERIAL:**

- 14 GAUGE, TYPE 300 STAINLESS STEEL



FTSG-1248

**FLOOR TROUGHS - STAINLESS STEEL 14GA**

12" WIDE	QTY	18" WIDE	QTY	24" WIDE	QTY
FTSG-1224		FTSG-1824		FTSG-2424	
FTSG-1236		FTSG-1836		FTSG-2436	
FTSG-1248		FTSG-1848		FTSG-2448	
FTSG-1260		FTSG-1860		FTSG-2460	
FTSG-1272		FTSG-1872		FTSG-2472	
FTSG-1284		FTSG-1884		FTSG-2484	
FTSG-1296		FTSG-1896		FTSG-2496	
FTSG-12108		FTSG-18108		FTSG-24108	
FTSG-12120		FTSG-18120		FTSG-24120	

## DETAILED SPECIFICATIONS

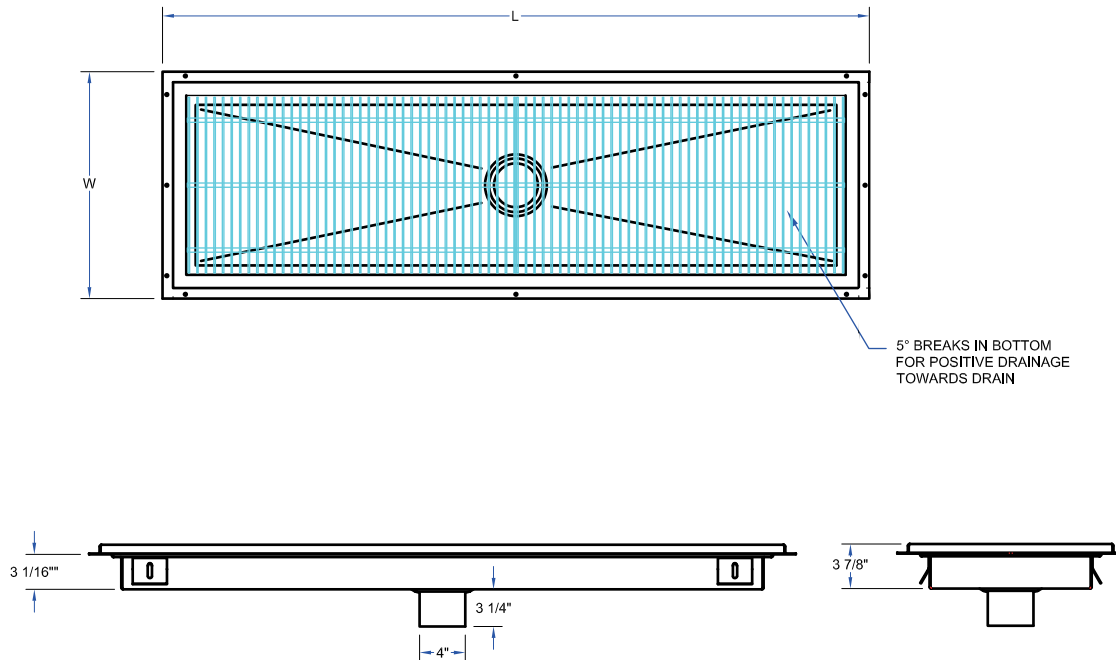

### FLOOR TROUGHS - STAINLESS STEEL 14GA

LENGTH	12" WIDE	WEIGHT (LBS)	18" WIDE	WEIGHT (LBS)	24" WIDE	WEIGHT (LBS)
24"	FTSG-1224	25	FTSG-1824	37	FTSG-2424	49
36"	FTSG-1236	37	FTSG-1836	56	FTSG-2436	75
48"	FTSG-1248	50	FTSG-1848	76	FTSG-2448	100
60"	FTSG-1260	62	FTSG-1860	93	FTSG-2460	125
72"	FTSG-1272	75	FTSG-1872	105	FTSG-2472	150
84"	FTSG-1284	90	FTSG-1884	115	FTSG-2484	175
96"	FTSG-1296	100	FTSG-1896	135	FTSG-2496	210
108"	FTSG-12108	112	FTSG-18108	150	FTSG-24108	230
120"	FTSG-12120	125	FTSG-18120	165	FTSG-24120	185

SOME UNITS SHIP UNASSEMBLED FOR REDUCED SHIPPING COST. ALL DIMENSIONS ARE TYPICAL. TOLERANCE +/- .500"  
 John Boos & Co. is constantly engaged in a program of improving products and therefore reserves the right to change specifications without prior notice.



3601 S. Banker St. • Effingham, IL 62401 • PO BOX 609 • quotes@johnboos.com

[www.johnboos.com](http://www.johnboos.com)

070717

721