



BLUE AIR Commercial Refrigeration Inc.

SINKS Stainless Steel Commercial 1 Compartment Sink

Product Specification

MODEL NAME	PRODUCT	OUT SIDE(W x D x H)	BOWL SIDE(W x D x H)	WEIGHT (lbs)
BSP-18	Prep Sink(18 x 18)	21 1/2" x 21 1/2" x 44 1/2"	18" x 18" x 13"	31
BS1-18/R	1 Compartment 1 Right Drain Board	39" x 24" x 44 1/2"	18" x 18" x 11"	42
BS1-18/L	1 Compartment 1 Left Drain Board	39" x 24" x 44 1/2"	18" x 18" x 11"	42
BS1-18/2D	1 Compartment 2 Drain Board	54" x 24" x 44 1/2"	18" x 18" x 11"	50

* BLUE AIR has the right to change specifications without further notice.

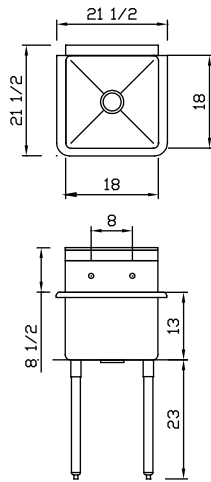
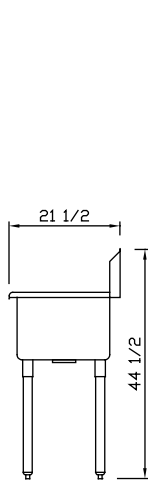

[BSP-18]

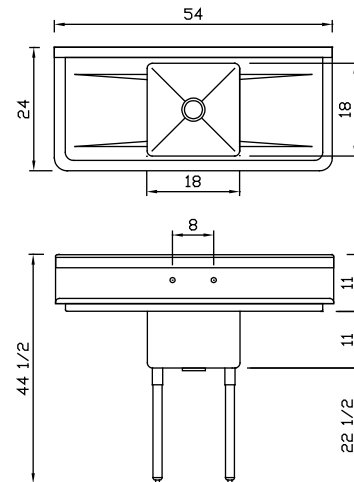

[BS1-18/2D]

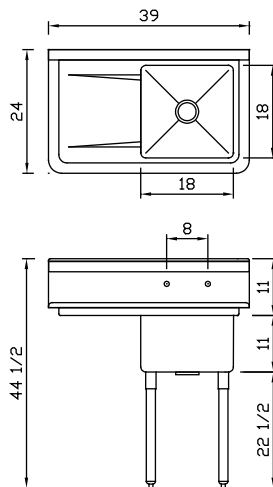
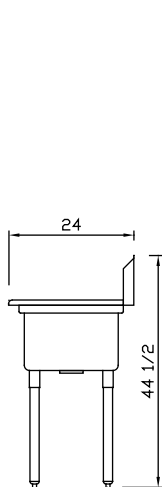

[BS1-18L]

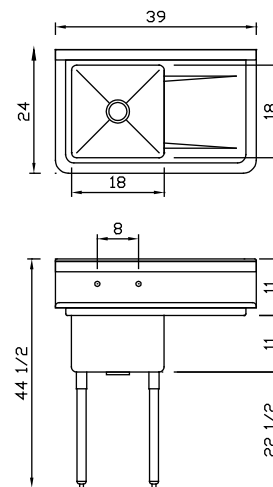

[BS1-18/R]



BLUE AIR Commercial Refrigeration Inc.

223 W. Rosecrans Ave.
Gardena, CA. 90248 USA

Tel : 1.866.677.8500 / 310.808.0102
Fax : 310.808.0242 / 310.808.0262
KaTom Restaurant Supply, Inc.

<http://www.blueairinc.com>
Email : info@blueairinc.com