



**John
BOOS**
Since 1887

ITEM #: _____ QTY: _____

MODEL #: _____

PROJECT NAME: _____

3601 S. Banker St. Effingham, IL 62401 • P.O. BOX 609 • Ph: (888) 431-2667 • Fax: (800) 433-2667

"ABPR" ALUMINUM MOBILE PAN RACKS - SIDE LOAD



FEATURES:

- 6063 ALUMINUM 1" SQUARE TUBING
- BOLTED CROSS RAILS
- 3" SPACING - 20 PAN CAPACITY
- 29-1/2" X 19-1/2" X 69"
- 5" CASTERS

CONSTRUCTION:

- RACK: 6063 ALUMINUM; MIG WELDED.

MATERIAL:

- 6063 ALUMINUM



ABPR-1820-3KDS



ABPR-1820-3KDS



ABPR-1820-3KDS

STANDARD MOBILE PAN RACK- SQUARE TOP DESIGN

MODEL #	QTY
ABPR-1820-3KDS	



NESTING RACKS

STANDARD MOBILE PAN RACK- ROUND TOP DESIGN

MODEL #	QTY
ABPR-1820-RKDS	

NESTED MOBILE PAN RACK- SQUARE TOP DESIGN

MODEL #	QTY
ABPR-1820-ZNS	

DETAILED SPECIFICATIONS

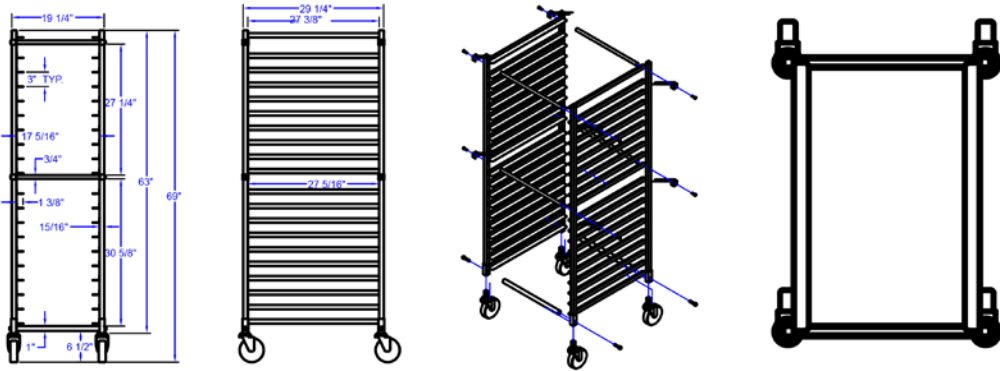

STANDARD MOBILE PAN RACK- SQUARE TOP DESIGN

MODEL #	LENGTH	WIDTH	HEIGHT	WT. (LBS)
ABPR-1820-3KDS	29-1/4"	19-1/4"	69"	30

KNOCK DOWN BOLT TOGETHER CONSTRUCTION

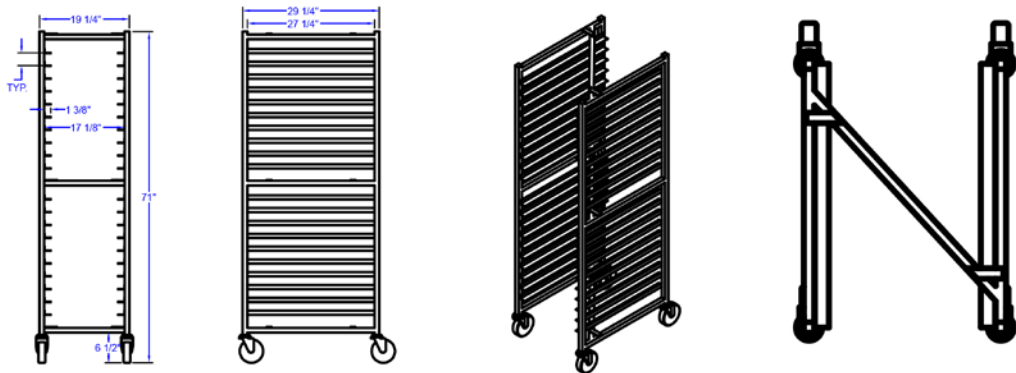

NESTED MOBILE PAN RACK- SQUARE TOP DESIGN

MODEL #	LENGTH	WIDTH	HEIGHT	WT. (LBS)
ABPR-1820-ZNS	29-1/4"	19-1/4"	71"	30

FULLY WELDED SET-UP CONSTRUCTION

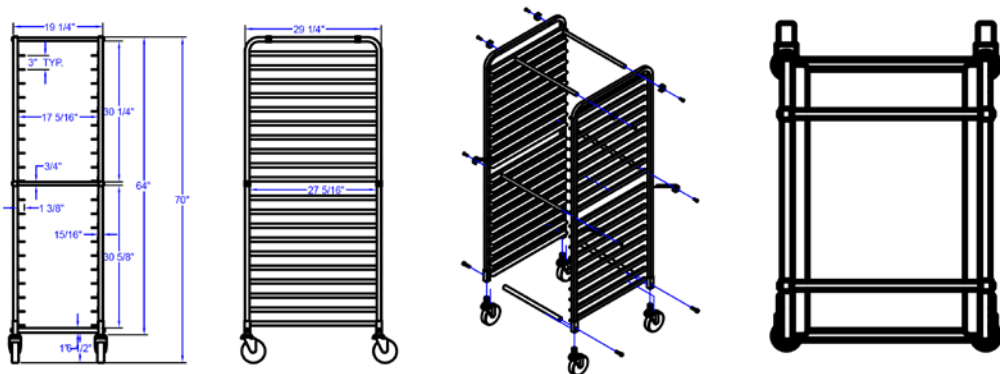

STANDARD MOBILE PAN RACK- ROUND TOP DESIGN

MODEL #	LENGTH	WIDTH	HEIGHT	WT. (LBS)
ABPR-1820-RKDS	29-1/4"	19-1/4"	70"	30

KNOCK DOWN BOLT TOGETHER CONSTRUCTION

SOME UNITS SHIP UNASSEMBLED FOR REDUCED SHIPPING COST. ALL DIMENSIONS ARE TYPICAL. TOLERANCE +/- .500"
 John Boos & Co. is constantly engaged in a program of improving products and therefore reserves the right to change specifications without prior notice.