



Outperform every day.™

Project:

Item Number:

Quantity:

ServeWell® Hot Food Table

The Vollrath Company, L.L.C.

SERVEWELL® HOT FOOD TABLE



ServeWell® 3-Well Hot Food Table

DESCRIPTION

We build each ServeWell® unit with heavy-gauge stainless steel, and engineer the body, legs, and base for strength and durability. The complete line of ServeWell® food tables are designed to eliminate the frustrations you have had with traditional food service units.

Each well will accept full-size or fractional pans to 6" (15.24 cm) deep, and can be used with standard adaptor plates and insets for serving flexibility.

FEATURES

- **Thermoset Fiber-Reinforced Resin Wells** – self-insulating and maximum energy efficiency. Will not rust or pit. Clean easily by wiping off water deposits from the non-metallic surface.
- **Thermostatic Heat Controls** – automatically adjust for water temperature and food volume changes to reduce food waste.
- **Capillary Tube Thermostats** – control supply power only when needed for maximum power efficiency.
- **Low-water indicator light** – eliminates guesswork.
- **Dome Heating Elements** – use up to 25% less energy and concentrate energy into the wells. Non-stick surface prevents scale build-up for easy cleaning and longer operating life. Elements are cast-in for longer service life and greater energy transfer.
- **Wells** – Wide no-drip lips on wells keep top surface dry. Equipped with individual brass drain valves.
- Recommend using up to 4" (10.2 cm) deep food pans – standard and fractional sizes.
- Plate shelf standard.
- Polyethylene NSF-approved cutting board standard.
- Mechanical guards on all controls and power switch for safety and reliability.
- 10ft. (3 m) power cord bottom-mounted to stay out of the way.
- 20 gauge stainless steel top and undershelf, 16 gauge legs.
- Standard adjustable stationary legs or optional caster set.
- Shipped knocked down.

WARRANTY: All models shown come with Vollrath's standard warranty against defects in materials and workmanship. For full warranty details, please refer to the Vollrath Equipment and Smallwares Catalog.

Agency Listings



Due to continued product improvement, please consult www.vollrath.com for current product specifications.

MODELS

Model	Description	Model	Description
38102	700W/120V 2 Well	38004	480W/120V 4 Well
38103	700W/120V 3 Well	38005	480W/120V 5 Well
38104	700W/120V 4 Well	38116	600-800W/208-240V 2 Well
38105	700W/120V 5 Well	38117	600-800W/208-240V 3 Well
38002	480W/120V 2 Well	38118	600-800W/208-240V 4 Well
38003	480W/120V 3 Well	38119	600-800W/208-240V 5 Well

PERFORMANCE CRITERIA

ServeWell® Hot Food Table are designed to hold heated prepared foods at temperatures above the HACCP "danger zone" of 140° F (60° C). The performance standard is measured using the NSF mixture preheated to 165° F (73.9° C). The unit will hold the temperature of this product above 150° F (65.6° C). The temperature will be maintained best when the food product is held using pans with covers, the proper water level is maintained in the well, and the food product is stirred regularly.

ACCESSORIES Dimensions shown in inches (cm)

Work/Overshelf w/o Acrylic Panel



Item	Length x Width x Height
38042	32 x 10 x 13 (81.3 x 25.4 x 33)
38043	46 x 10 x 13 (116.8 x 25.4 x 33)
38044	61¼ x 10 x 13 (155.6 x 25.4 x 33)
38045	76 x 10 x 13 (193 x 25.4 x 33)

Double-Deck Overshelf w/o Acrylic Panel (Not pictured)

Item	Length x Width x Height
38032	32 x 10 x 26 (81.3 x 25.4 x 66)
38033	46 x 10 x 26 (116.8 x 25.4 x 66)
38034	61¼ x 10 x 26 (155.6 x 25.4 x 66)
38035	76 x 10 x 26 (193 x 25.4 x 66)

Single Deck Cafeteria Guard

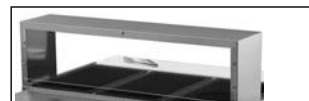

Item	Length x Width x Height
38052	32 x 10 x 13 (81.3 x 25.4 x 33)
38053	46 x 10 x 13 (116.8 x 25.4 x 33)
38054	61¼ x 10 x 13 (155.6 x 25.4 x 33)
38055	76 x 10 x 13 (193 x 25.4 x 33)

Buffet Breath Guards*



*For units only with 4 guide holes per side.

Item	Length x Width x Height
38062	32 x 35¾ x 23½ (81.2 x 89.8 x 59.7)
38063	46 x 35¾ x 23½ (116.8 x 89.8 x 59.7)
38064	61¼ x 35¾ x 23½ (155.6 x 89.8 x 59.7)
38065	76 x 35¾ x 23½ (193 x 89.8 x 59.7)

Operator Side Poly Cutting Board



Item	Length x Width x Height
38072	32 x 8 x 1 (81.3 x 20.3 x 2.5)
38073	46 x 8 x 1 (116.8 x 20.3 x 2.5)
38074	61¼ x 8 x 1 (155.6 x 20.3 x 2.5)
38075	76 x 8 x 1 (193 x 20.3 x 2.5)

Customer Side Plate Rest



Item	Length x Width x Height
38092	32 x 8 x 1 (81.3 x 20.3 x 2.5)
38093	46 x 8 x 1 (116.8 x 20.3 x 2.5)
38094	61¼ x 8 x 1 (155.6 x 20.3 x 2.5)
38095	76 x 8 x 1 (193 x 20.3 x 2.5)

Caster Set



Item	Description
38099	4 (10.2) swivel wheels, two with brakes
3809934	4 (10.2) swivel wheels, two with brakes, ADA HT

Approvals	Date



Outperform every day.™

www.vollrath.com

The Vollrath Company, L.L.C.
1236 North 18th Street
Sheboygan, WI 53081-3201 U.S.A.
Customer Service: 800.628.0830
Canada Customer Service: 800.695.8560
Main Fax: 800.752.5620 or 920.459.6573

Technical Services: 800.628.0832
Technical Services Fax: 920.459.5462

SERVEWELL® HOT FOOD TABLE

DIMENSIONS

Dimensions shown in inches (cm).

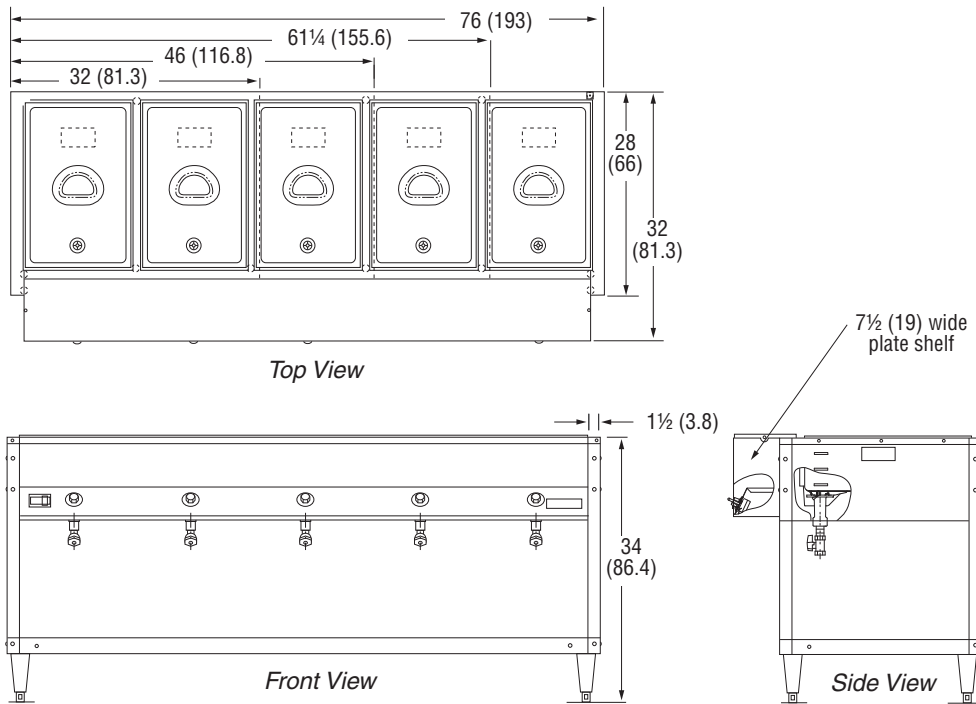

SPECIFICATIONS

Item	Description	Volts Single Phase Only	Watts Per Well	Watts Total	Electrical Service (A)	Amps	Plug
700W/120V							
38102	2-well	120V	700	1400	15	11.7	NEMA 5-15P
38103	3-well	120V	700	2100	30	17.5	NEMA 5-30P
38104	4-well	120V	700	2800	30	23.3	NEMA 5-30P
38105	5-well	120V	700	3500	50	29.2	NEMA 5-50P
480W/120V							
38002	2-well	120V	480	960	15	8	NEMA 5-15P
38003	3-well	120V	480	1440	15	12	NEMA 5-15P
38004	4-well	120V	480	1920	20	16	NEMA 5-20P
38005	5-well	120V	480	2400	30	20	NEMA 5-30P
600-800W/208-240V							
38116	2-well	208-240V	600-800	1200-1600	15	6.7	NEMA 6-15P
38117	3-well	208-240V	600-800	1800-2400	15	10	NEMA 6-15P
38118	4-well	208-240V	600-800	2400-3200	20	13.3	NEMA 6-20P
38119	5-well	208-240V	600-800	3000-4000	30	16.6	NEMA 6-30P

Notes: Dedicated circuit may be required for higher currents.
 ServeWell® Hot Food Table orders cannot be cancelled or returned.

Receptacles

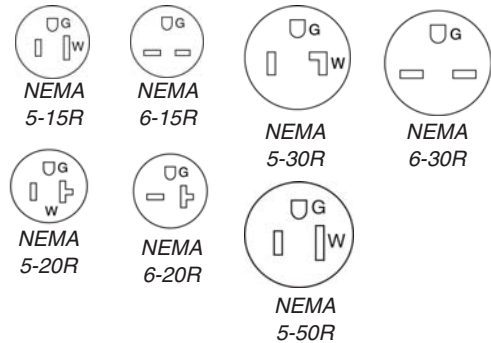

Outperform every day.™

www.vollrath.com

The Vollrath Company, L.L.C.
 1236 North 18th Street
 Sheboygan, WI 53081-3201 U.S.A.
 Customer Service: 800.628.0830
 Canada Customer Service: 800.695.8560
 Main Fax: 800.752.5620 or 920.459.6573

Technical Services: 800.628.0832
 Technical Services Fax: 920.459.5462