

## CamKiosk® Cart

**Without Canopy (No image shown)**

Models: KVC854, KVC856

**With Canopy**

Models: KVC854C, KVC856C

**StoreSafe**

### Features & Benefits

- Offers opportunity to capture new or incremental sales in non-traditional locations.
- Double-wall, high-density, polyethylene construction is impact resistant and will not dent, crack, bubble, chip or break. Can be wiped or steam cleaned.
- Polyurethane foam core provides added strength and durability.
- Available with four (4) or six (6) GN 1/1 full size, 12<sup>3</sup>/<sub>4</sub>" x 20<sup>7</sup>/<sub>8</sub>" (32,5 x 53 cm), 6" (15,2 cm) deep food pan wells. Work top can be configured to offer multiple serving options with the use of Divider Bars (DIV12) and fractional size food pans.
- Two (2) fully insulated storage compartments with molded-in rails, store hot or cold foods for 4 + hours. These two (2) compartments have externally mounted thermometers that measure the air temperature in each compartment.
- GN 1/1 Full Size Food Pan capacity per compartment:
  - 12 each, 2<sup>1</sup>/<sub>2</sub>" (6,4 cm) deep
  - 8 each, 4" (10,2 cm) deep
  - 6 each, 6" (15,2 cm) deep
  - or 4 each, 8" (20,3 cm) deep
- Sneeze guard meets food preparation requirements for both height and length.
- Non-insulated compartment in the middle, locks to keep cash drawer and other valuables safe.
- Removable menu board with erasable surface included.
- Display shelf promotes food merchandising for building add-on purchases.
- Molded-in handles on both sides make the cart easy to transport.
- Four (4) each 6" (15,2 cm) x 2" (5,1 cm) heavy duty swivel casters, two (2) with brakes ensure easy transport across a lobby floor or campus.
- Handsome canopy and display panel can both be personalized. Standard display panel comes with Cruising Café logo unless otherwise specified. Standard canopy is not printed.
- Non-electrical.
- Some assembly required.
- System available in five (5) solid colors and one (1) combined color. Two Standard canopy colors available, unless otherwise specified

Item No. \_\_\_\_\_

Specifier Identification No. \_\_\_\_\_

Model No. \_\_\_\_\_

Quantity \_\_\_\_\_

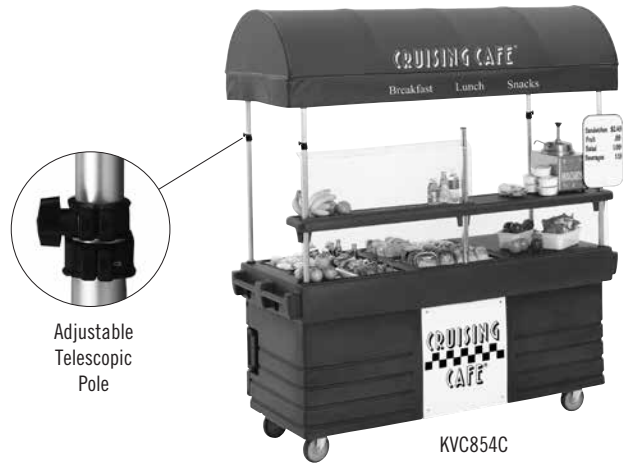

Adjustable Telescopic Pole



KVC854C



4 Well Top

- GN Food Pan configuration for top row left to right includes:
- Two (2) each 1/2 Long Food Pans
  - Three (3) each 1/3 Food Pans with two DIV12 Divider Bars

- GN Food Pan configuration for bottom row left to right includes:
- One (1) each 1/1 Food Pan
  - Two (2) each 1/4 and one (1) 1/2 Food Pans with one (1) DIV12 Divider Bar



6 Well Top

- GN Food Pan configuration for top row left to right includes:
- Three (3) each 1/3 Food Pans with two (2) DIV12 Divider Bars
  - One (1) each 1/1 Food Pan
  - Two (2) each 1/4 and One (1) 1/2 Food Pans with One (1) DIV12 Divider Bar

- GN Food Pan configuration for bottom row left to right includes:
- Two (2) each 1/2 Long Food Pans
  - Two (2) each 1/2 Food Pans with One (1) DIV12 Divider Bar
  - One (1) each optional Cutting Board

# CamKiosk® Cart

**Without Canopy (No image shown)**

Models: KVC854, KVC856

**With Canopy**

Models: KVC854C, KVC856C

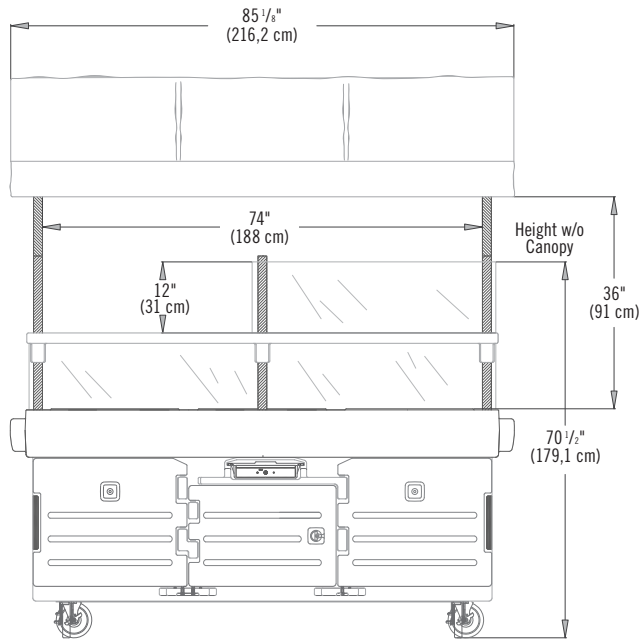

KIOSK CART

Item No. \_\_\_\_\_

Specifier Identification No. \_\_\_\_\_

Model No. \_\_\_\_\_

Quantity \_\_\_\_\_

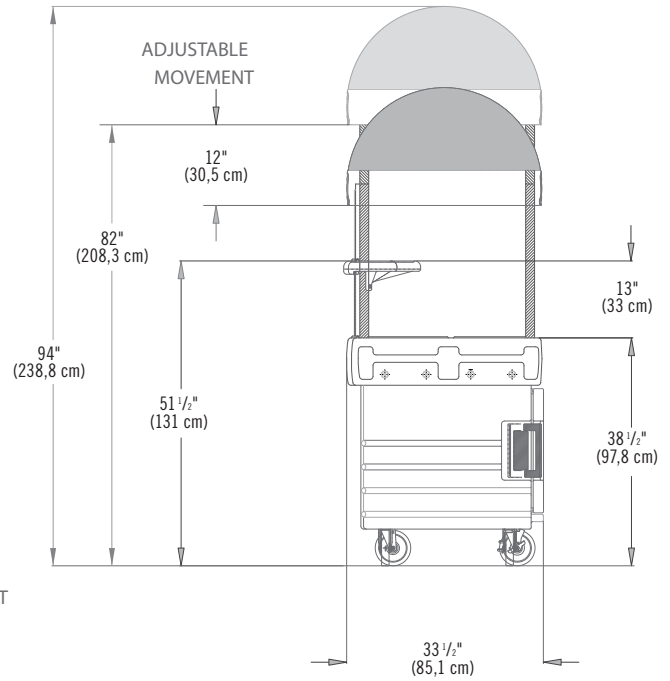

## Specifications

Code	Description	Overall Dimension L x W x H (Including Canopy)	Shipping weight lbs./cube (Kg/m³)
<b>Without Canopy</b>			
KVC854	Cart w/4 pan wells	85 1/8" x 33 1/2" x 70 1/2" (216,2 x 85,1 x 179,1 cm)	302/76.6 (137/2,2)
KVC856	Cart w/6 pan wells	85 1/8" x 33 1/2" x 70 1/2" (216,2 x 85,1 x 179,1 cm)	305/76.6 (138,4/2,2)
<b>With Canopy</b>			
KVC854C	Cart w/4 pan wells	85 1/8" x 33 1/2" x 94" (216,2 x 85,1 x 238,8 cm)	347/102.1 (157,4/2,9)
KVC856C	Cart w/6 pan wells	85 1/8" x 33 1/2" x 94" (216,2 x 85,1 x 238,8 cm)	349/102.1 (158,3/2,9)

Dimension Tolerance: +/- 1/4" (0,64 cm)

## Optional Accessories

Well Cover	<input type="checkbox"/> WCR1220	Bridge Connector	<input type="checkbox"/> KMC24
Cutting Board	<input type="checkbox"/> CB1220	Camchiller® GN 1/1 Full Size	<input type="checkbox"/> CP1220
ThermoBarrier®	<input type="checkbox"/> 1600DIV	Camchiller® GN 1/2 Half Size	<input type="checkbox"/> CP1210
		Camchiller®	<input type="checkbox"/> CP814

\*Note: For attaching to CamKiosk Work Station or Hand Sink Cart only.  
See www.cambro.com for dimensions and additional details.

## Standard Colors

- CamKiosk:
- Granite Gray (191)
  - Granite Green (192)
  - Navy Blue (186)
  - Hot Red (158)
  - Kentucky Green (519)
  - Black Base with Granite Gray Top & Door (426)

- Canopy:\*\*
- Kentucky Green (519)
  - Beige (157)

\*\*The standard canopy colors are: Beige Canopy with CamKiosk in Navy Blue (186) & Hot Red (158), Kentucky Green Canopy with CamKiosk in Granite Gray (191), Granite Green (192), Kentucky Green (519) & Two-tone options (425) & (426)

- Well Cover:
- Black (110)
  - Hot Red (158)
  - Navy Blue (186)
  - Kentucky Green (519)
  - Granite Gray (191)
  - Granite Green (192)

## Architect Specs

The portable foodservice cart shall be a CamKiosk, manufactured by Cambro Mfg. Co., Huntington Beach, CA 92648 U.S.A. It shall be a Cambro Model... It shall be made of polyethylene and foam-injected polyurethane. It shall have molded-in handles, four (4) each 6" (15,2 cm) x 2" (5,1 cm) heavy duty swivel casters, two (2) with brakes on a molded-in chassis. It shall have four (4) or six (6) GN 1/1 Full Size Food Pan, 6" (15,2 cm) deep wells. It shall have two (2) work top configurations and two (2) insulated storage compartments, with molded-in rails. It shall have a sneeze guard with a display shelf, a locking non-insulated storage compartment and a removable menu board. It shall come with or without a canopy. It will come with a display panel with Cruising Café logo or a personalized panel option. The CamKiosk shall be available in six (6) colors.



© Cambro Manufacturing Company 5801 Skylab Road, Huntington Beach, California 92647-2056-U.S.A.  
Telephone 714 848 1555 Toll Free 800 854 7631 Customer Service 800 833 3003