

## TRK55 Combination Food Processor

ITEM # \_\_\_\_\_  
 MODEL # \_\_\_\_\_  
 PROJECT NAME # \_\_\_\_\_  
 SIS # \_\_\_\_\_  
 AIA # \_\_\_\_\_



### TRK55 Combination Food Processor

603344 (TRK55) Combination Food Processor and  
 5.5 Qt Bowl VCM 1p/60Hz

### Short Form Specification

Item No. \_\_\_\_\_

The TRK55 is a versatile machine capable of changing from vegetable slicer to food processor in a matter of seconds. When using the vegetable slicer attachment, it is possible to quickly and easily make over 70 different types of cuts in slicing, cubing, grating, french fry cuts and more. When using the food processing attachment, it is possible to mince meat, create elaborate: mousses, stuffings, creams, and pastries. The capacities of the TRK55 make it a perfect complement for kitchens of any size.



Approval: \_\_\_\_\_

### Main features

- Combination continuous feed food processor and vertical cutter mixer machine.
- Power: TRK55 - 1.3HP
- Vegetable Cutting at 4 speeds up to 430 RPM. Food Processing at 10 variable speeds: 300-3300 RPM
- TRK55 - 1kW
- Red OFF, Green ON Buttons
- Compact Design
- Angled Front
- Planetary Drive
- Large Round and Large 3/4 Moon Hopper, also comes with food processing bowl.
- Hopper easily removed for cleaning.
- Magnetic safety system and motor brake. Prevents machine from running when pusher plate swings away or is open.
- Automatic restart of the machine with the 3/4 Moon shaped pusher in position.
- Delivered with :
- Complete selection of 32 blades and disks available.
- Processor has dicing and french fry capabilities.
- Dimensions: (H x L x W): 19.75" x 19.7" x 9.9"
- Approx. shipping weight—56 lbs
- ETL electrical and sanitation listed/CETL (Canada).
- NEMA# 5-20P.
- 2 year parts warranty, 1 year labor.

### Included Accessories

- 5.5 Qt. Stainless steel bowl for cutter mixer (PNC 653590)
- Lid + Bowl scraper for 5.5 Qt. Cutter Mixer (PNC 653591)
- Microtooth blade rotor for 5.5 Qt. Cutter Mixer (PNC 653582)

### Accessories

- 5.5 Qt. Stainless steel bowl for cutter mixer (PNC 653590)
- Lid + Bowl scraper for 5.5 Qt. Cutter Mixer (PNC 653591)
- Microtooth blade rotor for 5.5 Qt. Cutter Mixer (PNC 653582)
- Smooth blade rotor for 5.5 Qt. Cutter Mixer (PNC 653581)
- Kit Veg. Slicer for Variable Speed Cutter Mixer (PNC 653594)
- Slicing Blade 9/16" (14mm) (PNC 653185)
- Slicing Blade 5/16" (8 mm) (PNC 653108)
- Slicing Blade 3/8" (10 mm) (PNC 653110)
- Slicing Blade 1/8" (3 mm) (PNC 653103)
- Slicing Blade 1/4" (6 mm) (PNC 653106)
- Slicing Blade 1/32" (1 mm) (PNC 653101)
- Slicing Blade 1/16" (2 mm) (PNC 653102)
- Julienne Blade 5/32" (4 x 4 mm) (PNC 653154)
- Julienne Blade 1/8" (3 x 3 mm) (PNC 653153)
- Julienne Blade 1/16" (2 x 2 mm) (PNC 653214)
- Dicing Grid (5 x 5 x 5 mm) (PNC 653566)
- Dicing Grid 5/16" (8 x 8 x 8 mm) (PNC 653567)
- Dicing Grid 3/8" (10 x 10 x 10 mm) (PNC 653568)
- Dicing Grid 1/2" (12 x 12 x 12 mm) (PNC 653569)
- Dicing Grid 3/4" (20 x 20 x 20 mm) (PNC 653570)
- Grid for French Fries or Vegetable Sticks 1/4" (6 x 6 x 6 mm) (PNC 653571)
- Grid for French Fries or Vegetable Sticks 5/16" (8 x 8 x 8 mm) (PNC 653572)
- Grid for French Fries or Vegetable Sticks 3/8" (10 x 10 x 10 mm) (PNC 653573)
- Grating blade for Parmesan and Bread (PNC 653170)
- Grating Blade for Nuts, Chocolate, Bread Crumbs (PNC 653008)
- Grating Blade (XX Course) 23/64" (9 mm) (PNC 653498)
- Grating Blade (Medium) 1/8" (3 mm) (PNC 653163)
- Grating Blade (Fine) 1/16" (2 mm) (PNC 653162)
- Grating Blade (Extra Course) 9/32" (7 mm) (PNC 653167)
- Grating Blade (Course) 5/32" (4 mm) (PNC 653164)
- Curved Serrated Slicing Blade 3/8" (10 mm) (PNC 653511)
- Curved Serrated Slicing Blade 3/16" (5 mm) (PNC 653115)
- Curved Serrated Slicing Blade 1/8" (3 mm) (PNC 653113)
- Curved Serrated Slicing Blade 1/32" (1 mm) (PNC 653111)
- Curved Serrated Slicing Blade 1/16" (2 mm) (PNC 653112)
- Wavy Cut Slicing Blade 1/8" (3 mm) (PNC 653123)
- Wavy Cut Slicing Blade 1/4" (6 mm) (PNC 653126)
- Wavy Cut Slicing Blade 1/16" (2 mm) (PNC 653122)
- Stainless steel Worktable Folding Shelves+Blade Rack (PNC 653283)
- Table with Hotel Pan Polycarbonate Tray (PNC 653180)

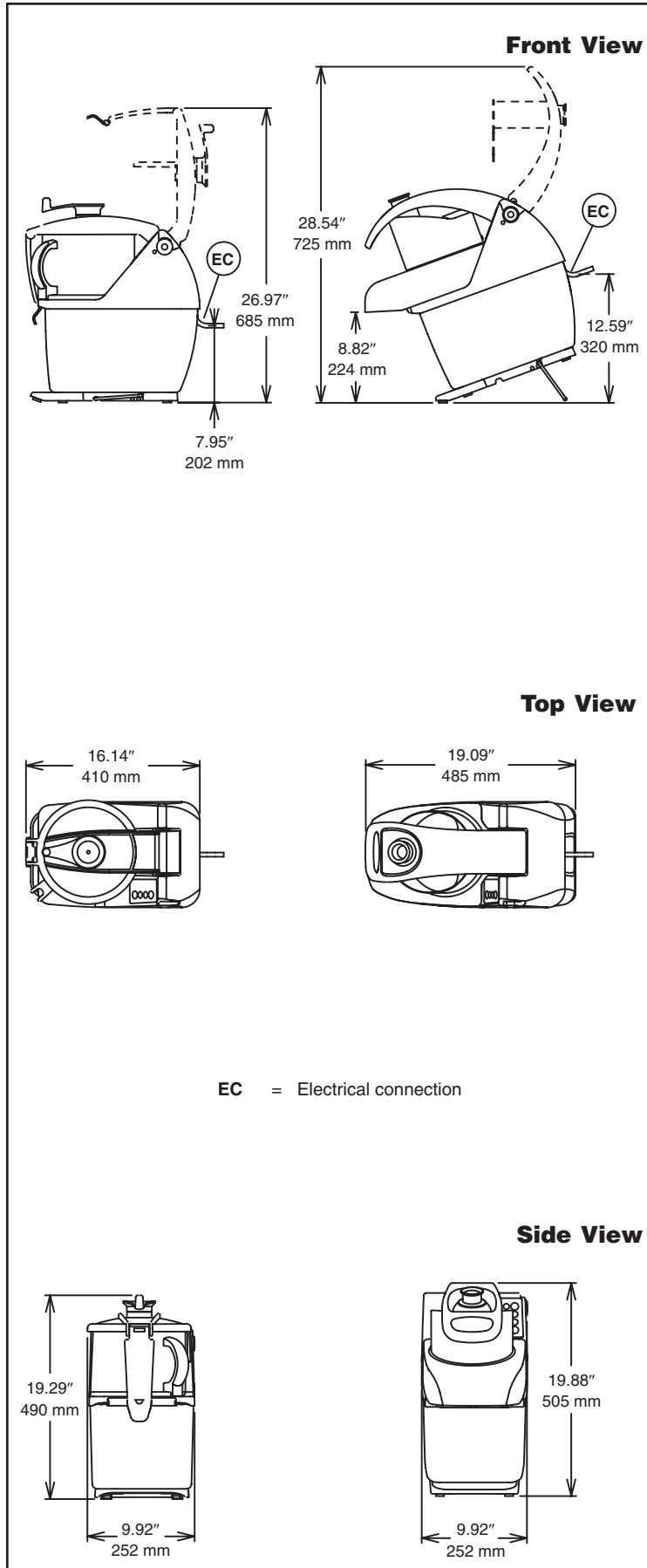

### Electric

Supply voltage:

603344 (TRK55) 1p/60Hz – 6A - 1.3HP

### Key Information

#### NEW FEATURES

- Wide range of functions: slicing, mincing, grating, shredding and cutting into chips or cubes of all sizes.
- Plate speed at 430 RPM for precise cutting, slicing and dicing.
- Large round hopper (8.5") allows food of greater dimension to be processed.
- Feeding arm with integrated long-vegetable hopper (tube pusher), 60 mm in diameter. Ideal for carrots, zucchini and cucumbers.
- Base inclined at 20° provides easy loading and discharging.
- High discharge zone permits the use of deep GN containers (up to 8 inches in height).
- Feeding arm and hopper are made entirely in Stainless steel. Aluminium motor housing.
- Plates and ejector may be removed in seconds by opening the cover.
- All parts that come into contact with the food are in Stainless steel or plastic, can be removed for easy cleaning and are dishwasher safe.
- IPX5 (IP55) flat panel touch-control, waterproof panel.
- Green button indicates ON, Red button indicates OFF.
- Pulse control for precise slicing.
- Asynchronous industrial motor with no brushes for high reliability and quiet functioning. Stainless steel motor shaft.
- Two separate safety switches stop the machine in order to protect the operator from potentially dangerous conditions.
- IP24 throughout entire machine.

TRK55 Combination Food Processor

The company reserves the right to make modifications to the products without prior notice. All information correct at time of printing.

3-30-11