

# CW15-TC w/Plastic Funnel

18.4" x 19.4" x 9.0"  
(46.7cm x 49.3cm x 22.9cm)



- Models are space saving 9" wide (22.9cm)
- All stainless steel construction
- Pourover brewer requires no plumbing – completely portable
- SplashGard® funnel deflects hot liquids away from the hand
- Accommodates thermal carafe up to 8.5" (21.6 cm) tall
- Use in quick turn environments where high quality coffee is continuously refreshed
- PROP 65 Warning Decal included in packaging with equipment
- Servers not included unless otherwise noted

Agency:

Server(s) sold separately

## Specifications

**Product #:** 23001.0040

**Water Access:** Not Plumbed

**Finish:** Stainless

**Funnel:** Black Plastic

## Additional Features

## Electrical & Capacity

Volts	Amps	Watts	Cord Attached	Plug Type	8oz cups/hr 236ml cups/hr	Input H <sup>2</sup> O Temp.	Phase	# Wires plus Ground	Hertz
120	11.4	1370	Yes	NEMA 5-15P	62	60°F (15.5°C)	1	2	60

## Plumbing Requirements

PSI	kPa	Fitting Supplied	Water Flow Required (GPM)
-	-	-	-

## CAD Drawings

2D	Revit	KLC
●		



BUNN® reserves the right to change specifications and product design without notice. Such revisions do not entitle the buyer to corresponding changes, improvements, additions or replacements for previously purchased equipment. For most current specifications and other info visit [bunn.com](http://bunn.com).

Created on:  
07/18/2019

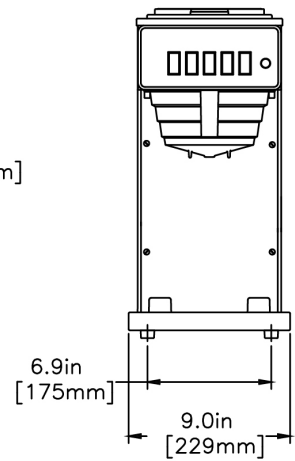
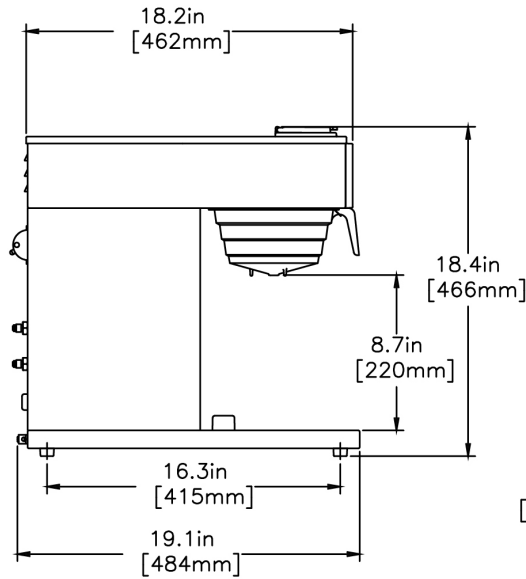
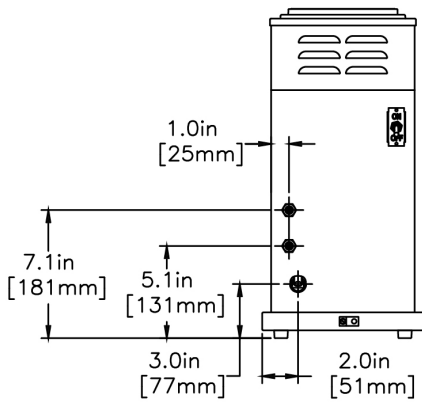
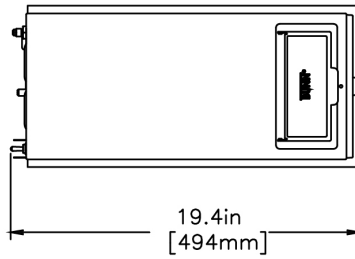

	Unit			Shipping				
	Width	Height	Depth	Width	Height	Depth	Weight	Volume
English	9.0 in.	18.4 in.	19.4 in.	11.9 in.	24.8 in.	25.9 in.	29.200 lbs	4.037 ft <sup>3</sup>
Metric	22.9 cm	46.7 cm	49.3 cm	30.2 cm	63.0 cm	65.8 cm	13.245 kgs	0.114 m <sup>3</sup>



BUNN® reserves the right to change specifications and product design without notice. Such revisions do not entitle the buyer to corresponding changes, improvements, additions or replacements for previously purchased equipment. For most current specifications and other info visit [bunn.com](http://bunn.com).

Created on:  
07/18/2019

Related Products & Accessories: CW15-TC w/Plastic Funnel(23001.0040)



FILTERS,REGULAR1M  
500/2 50/CL

Product #: 20115.0000



WATER FILTER  
SYSTEM,EQ-17-TL

Product #: 30200.1000



BUNN® reserves the right to change specifications and product design without notice. Such revisions do not entitle the buyer to corresponding changes, improvements, additions or replacements for previously purchased equipment. For most current specifications and other info visit [bunn.com](http://bunn.com).

Created on:  
07/18/2019

# Serving & Holding Options: CW15-TC w/Plastic Funnel(23001.0040)



THERMAL CARAFE, BLK  
1.9L 12PK

Product #:36029.0000



THERMAL CARAFE, BLK  
1.9L 1PK

Product #:36029.0001



THERMAL CARAFE,ORN  
1.9L 12PK

Product #:36252.0000



THERMAL CARAFE,ORN  
1.9L 1PK

Product #:36252.0001



CARAFE,SST 1.9L SHRT  
BLK 1

Product #:40163.0000



CARAFE,SST 1.9L SHRT  
ORN 1/

Product #:40163.0001



CARAFE,SST 1.9L SHRT  
BLK 12/

Product #:40163.0100



CARAFE,SST 1.9L SHRT  
ORN 12/

Product #:40163.0101



BUNN® reserves the right to change specifications and product design without notice. Such revisions do not entitle the buyer to corresponding changes, improvements, additions or replacements for previously purchased equipment. For most current specifications and other info visit [bunn.com](http://bunn.com).

Created on:  
07/18/2019