

MOTAK

Ice Cube Machine

Model #: PKM0335FA

Product Details

- Black exterior is smudge and fingerprint resistant
- Removable water shield, distribution tube, pump floats, and trough provide for easy cleaning
- Food zone is easily accessible



Primary Applications



C-Stores

Bars/Pubs

Hotels

Restaurants

Certifications



Specifications

Ice Production (24/hr cycle)

Produces full-sized ice cubes. See chart below for production rates at various air and water temps.

Air Temperature	70°	90°
Water Temperature	50°	70°
Power Usage (kWh/100lbs.)	N/A	6.25
Water Usage/100 lbs.	20 gal.	20 gal.
Ice Production (lbs./24hr.)	325 lbs.	225 lbs.

Full-sized cube dimensions

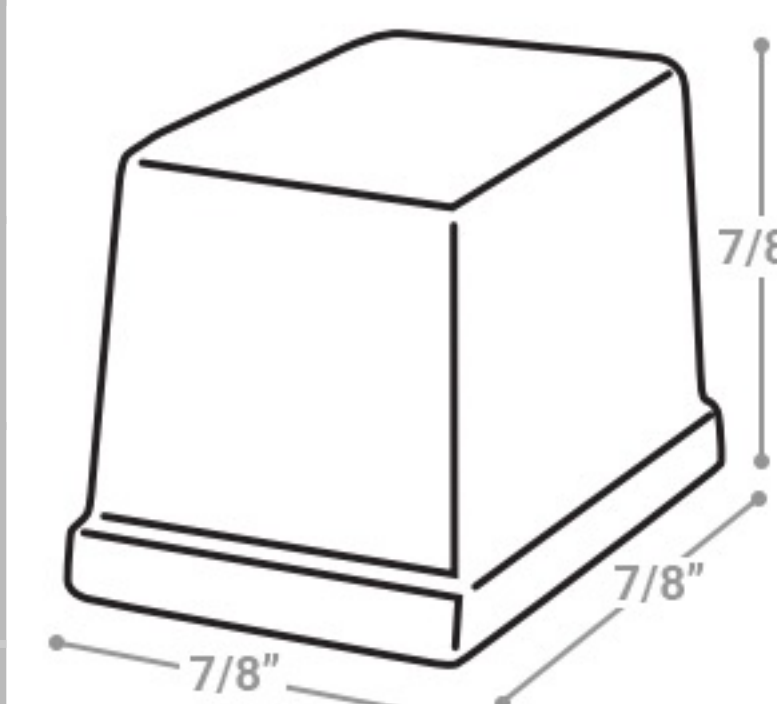

Compare to Other Available Models

	PKM0335FA	PKM0535FA	PKM0425FA
Voltage	115v/60hz/1ph	115v/60hz/1ph	115v/60hz/1ph
Refrigerant	R410A	R410A	R410A
Min. Circuit Ampacity	9.44 AMPS	12.7 AMPS	11.3 AMPS
Max. Fuse Size	15 AMPS	20 AMPS	20 AMPS
BTU/hr. (average/peak)	4600/5450	5300/6100	5400/6300
Air Inlet/Outlet	Back/Top	Back/Top	Back/Top
Dimensions	30"W x 24.5"D x 21.5"H (76.2 x 62.2 x 54.6 cm)	30"W x 24.5"D x 21.5"H (76.2 x 62.2 x 54.6 cm)	22"W x 24.5"D x 21.5"H (55.9 x 62.2 x 54.6 cm)
Shipping Dimensions	27.5"W x 28.75"D x 35"H (69.85 x 73.025 x 88.9 cm)	27.5"W x 28.75"D x 35"H (69.85 x 73.025 x 88.9 cm)	27.5"W x 28.75"D x 28.75"H (69.85 x 73.025 x 73.025 cm)
Gross Weight	145 lbs. (66kg)	156 lbs. (71kg)	137 lbs. (62kg)
Warranty	1-year Parts & Labor	1-year Parts & Labor	1-year Parts & Labor

MOTAK reserves the right to make changes to the design or specifications without prior notice.

011121