



The Signature of Quality®

Installation & Operation Instructions

Refrigerated SSRPF & SSRVS Models



Federal Industries
215 Federal AVE
Belleville, WI 53508

Toll Free: (800) 356-4206
WI Phone: (608) 424-3331
Fax: (608) 424-3234





Contents

(1)	Introduction	4
1.1	REGISTRATION & SERIAL NUMBER.....	4
(2)	Warning Labels & Safety Instructions	5
(3)	Pre-Installation Procedures.....	6
3.1	Inspection for Shipping Damage.....	6
(4)	General Electrical & Grounding.....	6
4.1	Cord Connected.....	6
4.2	Permanent Connected (Option)	6
4.3	Electrical information.....	7
(5)	Refrigeration Operation.....	8
5.1.1	Self-Contained Models.....	8
5.1.2	Remote Models.....	8
5.2	Evaporator Condensate Drain Tube	11
5.3	Condensate Pump	11
(6)	Installation Instructions	12
6.1	Locating the Display Case.....	12
6.2	Removing Case From Shipping Skid and General Installation	12
6.3	Cleaning.....	12
6.4	SSRVS33 UNDER COUNTER INSTALLATION	12
(7)	Shelving Installation & Removal	14
7.1	SHELF BRACKETS AND SUPPORTS INSTALLATION.....	14
7.2	Solid Shelf Installation	15
7.3	Glass Shelf Installation (OPTIONAL)	16
(8)	SSRPF CASE REAR DOORS (OPTION).....	17
(9)	NIGHT CURTAIN OPERATION	18
(10)	SECURITY NIGHT COVER (OPTION)	19
(11)	Operating Instructions	20
11.1	User Controls Overview	20
11.2	Power Switch.....	20
11.3	Light Switch	20
11.4	Electronic Temperature Control	20
11.4.1	Button and Display overview	21
11.4.2	Powering on control	21
11.4.3	Adjusting the set point.....	21
11.4.4	Entering Manual Defrost Mode.....	22
11.4.5	Error codes.....	22
11.5	Electronic Control Operation.....	23
11.6	Control Parameters	23

11.7	Initial Startup.....	24
11.8	Placing Product in Case.....	24
(12)	MAINTENANCE (LIGHTS).....	25
(13)	Periodic Maintenance (CLEAN CONDENSER).....	26
(14)	Cleaning Instructions.....	27
14.1	Daily Cleaning.....	27
14.2	Weekly Cleaning.....	28
14.3	Weekly Exterior Cleaning.....	29
(15)	Sale & Disposal.....	30
15.1	Owner Responsibility.....	30
(16)	Service Information.....	30
16.1	Special Service Instructions.....	31
16.2	Pre-Service checklist.....	31
	Lights do not operate.....	31
	Case temperature too warm (product is exceeding 41°F).....	31
(17)	Wiring Diagrams E555-1 EXCEL.....	32
17.1	Self Contained (<i>mfg'd before 1/1/19</i>).....	32
17.2	SELF CONTAINED (<i>MFG'D AFTER 1/1/19</i>).....	33
17.3	SELF CONTAINED (<i>MFG'D AFTER 12/1/19</i>).....	34
17.4	Remote (<i>mfg'd before 1/1/19</i>).....	35
17.5	REMOTE (<i>MFG'D AFTER 1/1/19</i>).....	36
17.6	REMOTE (<i>MFG'D AFTER 12/1/19</i>).....	37
(18)	Replacement Parts.....	38

(1) INTRODUCTION

Thank you for purchasing a Federal Industries display case. This manual contains important instructions for installing and servicing the SSRPF and SSRVS refrigerated self-service merchandisers. A repair parts list and wiring diagram are also included in the manual. Read all of these documents carefully before installing or servicing your case.

	<p>NOTICE Read this manual before installing your case. Keep this manual and refer to it before doing any service on the equipment. Failure to do so could result in personal injury or damage to the case.</p>
	<p>NOTICE Installation and service of the electrical components in the case must be performed by a licensed electrician. The portions of this manual covering components contain technical instructions intended only for persons qualified to perform electrical work.</p>
	<p>DANGER Improper or faulty hookup of electrical components in the case can result in severe injury or death. All electrical wiring hookups must be done in accordance with all applicable local, regional, or national standards.</p>

1.1 REGISTRATION & SERIAL NUMBER

It's important to keep a record of the model and serial number of your merchandiser for warranty and part identification. Please write them here for your quick reference.

Register your product online! Visit our website at www.federalindustries.com and register your product today.

Case Model _____ Serial Number _____

We're here to provide you with the best possible experience with your new product, however, we cannot cover everything about your merchandiser in this manual, so if you have any additional questions or issues, please see the SERVICE INFORMATION PAGE to find who you should contact.

(2) WARNING LABELS & SAFETY INSTRUCTIONS



This is the safety-alert symbol. When you see this symbol on your case or in the manual, be alert to the potential for personal injury or damage to your equipment.

Be sure you understand all safety messages and always follow recommended precautions and safe operating procedures.



NOTICE TO EMPLOYERS:
You must make sure that everyone who installs, uses, or services your case is thoroughly familiar with all safety information and procedures.

Important safety information is presented in this section and throughout the manual. The following signal words are used in the warning and safety messages:

DANGER:	Severe injury or death will occur if you ignore the message.
WARNING:	Severe injury or death can occur if you ignore the message.
CAUTION:	Minor injury or damage to your case can occur if you ignore the message.
NOTICE:	This is important installation, operation, or service information. If you ignore the message, you may damage your case.

The warning and safety labels shown throughout this manual are placed on your Federal Industries case at the factory. Follow all warning label instructions. If any warning or safety labels become lost or damaged, call our customer service department at (800) 356-4206 for replacements.

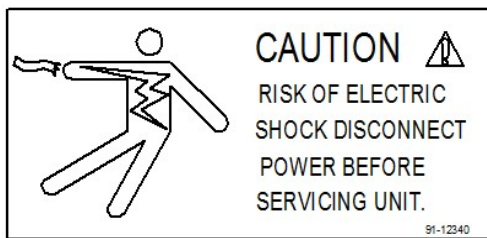

This label is located on the back of the display case

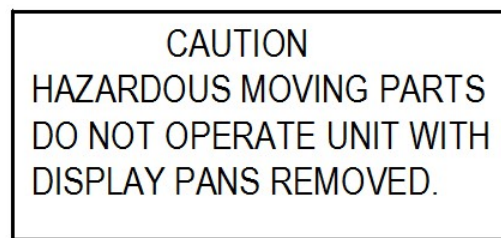

This label is located below the display pan.

(3) PRE-INSTALLATION PROCEDURES

3.1 INSPECTION FOR SHIPPING DAMAGE

You are responsible for filing all freight claims with the delivering truck line. Inspect all cartons and crates for damage as soon as they arrive. If damage is noted to shipping crates, cartons, or if a shortage is found, note this on the bill of lading (all copies) prior to signing.

If damage is discovered when the case is uncrated, immediately call the delivering truck line and follow up the call with a written report indicating concealed damage to your shipment. Ask for an immediate inspection of your concealed damage item. Crating material must be retained to show the inspector from the truck line.

(4) GENERAL ELECTRICAL & GROUNDING



DANGER:

Improper or faulty hookup of electrical components in the display case can result in severe injury or death.

4.1 CORD CONNECTED

All standard models are supplied with a power cord that is properly sized to the amperage requirements of the case. See the electrical data plate located on the rear left interior of the case for the proper circuit size for each case.

The cord is factory installed protruding from the bottom rear corner of the case.

A separate circuit for each display case is required to prevent other appliances on the same circuit from overloading the circuit and causing malfunction.

4.2 PERMANENT CONNECTED (OPTION)

Only a licensed electrician must perform all case electrical connections.

All electrical wiring hookups must be done in accordance with all applicable local, regional, or national electrical standards.

A separate circuit for each display case is required to prevent other appliances on the same circuit from overloading the circuit and causing malfunction.

The electrical service must be grounded upon installation.

See the electrical data plate located at the rear of the case for proper circuit size and wire ampacity.

The electrical connection box is accessible from the rear of the case with rear grill removed.

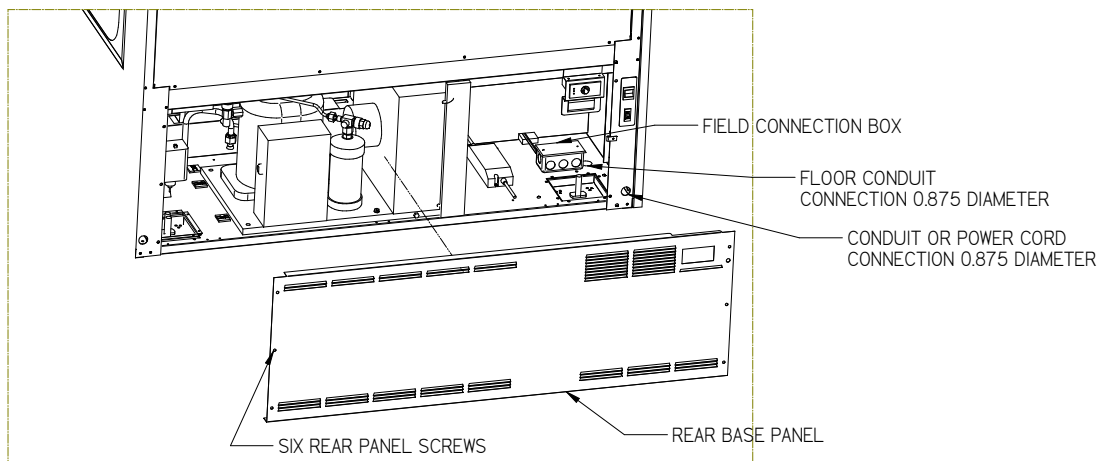

4.3 ELECTRICAL INFORMATION

PERMANENTLY CONNECTED					
MODEL	SELF CONTAINED			REMOTE	
	VOLTAGE	TOTAL AMPS	MAX FUSE SIZE	VOLTAGE	MAX FUSE SIZE
SSRPF3652/ SSRVS3642/ SSRVS3633/ SSRVS5033	120/60/1	14.3	20	120/60/1	15
SSRPF5052/ SSRVS5042/	230/60/1	9.5	20	120/60/1	15
SSRPF5952/ SSRVS5942/ SSRVS5933	230/60/1	14.5	20	120/60/1	15
SSRPF7752/ SSRVS7742/ SSRVS7733	230/60/1	14.5	20	120/60/1	15

CORD CONNECTED OPTIONAL			
MODEL	SELF CONTAINED		
	VOLTAGE	TOTAL AMPS	CORD STYLE
SSRPF3652/ SSRVS3642/ SSRVS3633/ SSRVS5033	120/60/1	14.3	20AMP NEMA 5-20
SSRPF5052/ SSRVS5042/	230/60/1	9.5	15AMP NEMA 6-15
SSRPF5952/ SSRVS5942/ SSRVS5933	230/60/1	14.5	20AMP NEMA 6-20
SSRPF7752/ SSRVS7742/ SSRVS7733	230/60/1	14.5	20AMP NEMA 6-20

E3555-1 EXCEL

(5) REFRIGERATION OPERATION

5.1.1 Self-Contained Models

SELF CONTAINED				
WITH ELECTRONIC CONTROL	SSRPF3652/ SSRVS3642/ SSRVS3633/ SSRVS5033	SSRPF5052/ SSRVS5042	SSRPF5952/ SSRVS5942/ SSRVS5933	SSRPF7752/ SSRVS7742/ SSRVS7733
Refrigeration R404 Charge	30 OZ	32 OZ	34 OZ	34 OZ
Refrigeration R449 Charge	30 OZ	32 OZ	34 OZ	34 OZ
Low Pressure Switch Cut In	80 psi	80 psi	80 psi	80 psi
Low Pressure Switch Cut Out	20 psi	20 psi	20 psi	20 psi
High Pressure Switch Cut Out	450 psi			

E3555-1 EXCEL

The self-contained models are shipped from the factory with a completely operational 404A (before 12/1/19) or R449a (after 12/1/19) refrigeration system and require no modifications or adjustments upon installation. Case must be installed as per the installation section of this manual to provide proper condenser air cooling.

The unit temperature is controlled by the electronic control outlined in the control section of this manual.

Note: The condenser fan runs continuously.

5.1.2 Remote Models

REMOTE				
	SSRPF3652/ SSRVS3642	SSRPF5052/ SSRVS5042	SSRPF5952/ SSRVS5942	SSRPF7752/ SSRVS7742
Refrigeration R449 Charge	CHARGED IN FIELD			
Remote Low Press. Switch Cut In	50			
Remote Low Press. Switch Cut Out	15			
Remote High Press. Switch Cut Out	450 psi			
BTU Requirement @90F/20F	4400	5400	6400	7400
	SSRVS3633	SSRVS5033	SSRVS5933	SSRVS7733
Refrigeration R449 Charge	CHARGED IN FIELD			
Remote Low Press. Switch Cut In	50			
Remote Low Press. Switch Cut Out	15			
Remote High Press. Switch Cut Out	450 psi			
BTU Requirement @90F/20F	3600	4400	5400	6400

E3555-1 EXCEL

The remote models are designed to use R449 refrigerant and shipped from the factory with the evaporator coil, expansion valve, sight glass, and refrigerant solenoid valve. Filter Drier must be installed in field. Electronic control runs identical to the self-contained models except the electronic control opens and closes a refrigeration solenoid valve located on the suction line instead of turning on and off a compressor. The solenoid valve closes and shuts off the refrigeration flow to the unit and initiates a pump down cycle. This will allow the remote low-pressure switch to open and shut off remote compressor.

The condensing unit and pressure controls are optionally supplied from the factory for remote location installation. The condensing unit must be mounted and wired by the installer. The high low-pressure switch must be wired in series with the compressor power supply as shown in diagram below

1. Mount condensing unit indoors as close to the remote display case as practical. The refrigeration line should be as short as possible and must not exceed 30 feet.
2. All refrigeration and/or electrical materials between the condensing unit and display case are to be supplied by installing contractor.
3. Route properly sized and designed refrigeration lines from the condensing unit to the cabinet.
4. Horizontal suction lines should be pitched downward towards the condensing unit at least 1/2" per 10' run to aid the oil drainage. A "P" trap must be installed in the suction line at the foot of every riser to insure oil return. Dry nitrogen must be used to flow through tubing while brazing refrigeration lines.
5. Suction line must be insulated the entire length with Armaflex (or equivalent). Do not run liquid line inside insulation with suction line.
6. The remote high/low-pressure control must be mounted, wired and set pressures by the installer.
7. Leak check condensing unit, cabinet, and all connecting tubing. Cabinet and condensing unit tubing should be checked to insure no leaks occurred during shipping or from rough handling.
8. Make certain all refrigeration valves are opened and evacuate system to 500 microns. Charge the system with refrigerant type specified on the data plates.

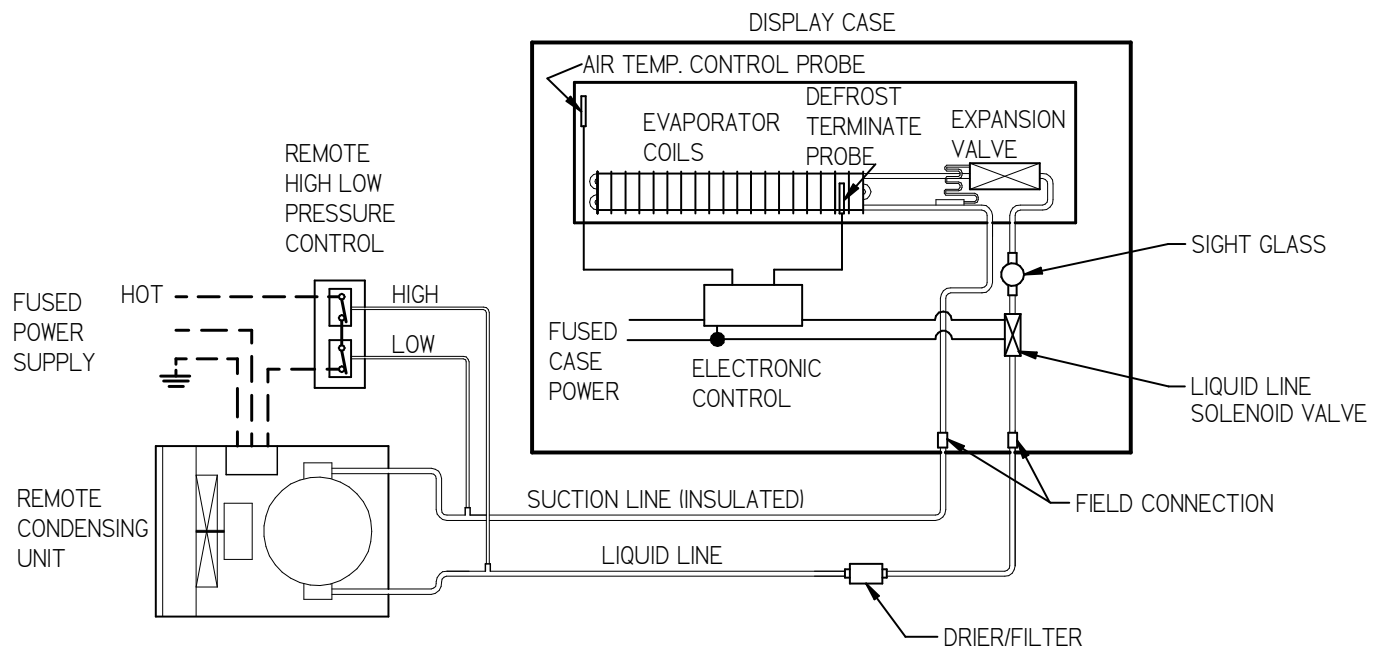

Figure 1 - Remote Refrigeration Diagram

Electronic Expansion Valve (EEV) After 12/19

A traditional TXV uses springs and a temperature bulb to open and close a valve port that controls the flow of refrigerant entering the evaporator coil. An electronic expansion valve (EEV) controls the refrigerant flow much more precisely, increasing the performance and efficiency of the refrigeration system. The EEV controls the flow of Refrigerant by opening and closing the valve port based on the response to signals sent to the EEV by an electronic controller. The electronic Control bases these signals by processing information provided from a temperature sensor and pressure transducer located on the discharge side of the evaporator coil.

These sensors monitor the evaporator superheat and protects the compressor from any liquid flood back under low superheat conditions.

EEV Controller Settings

The electronic expansion valve controller also allows the use of different types of refrigerants without the need to change the expansion valve.

The controller is set from the factory to run on 449A refrigerant and will not need any changes to the control unless another refrigerant is used.

Note: Check your State and Local regulations for approved refrigerants for your install location. Federal Industries is not liable for any alternate refrigerants used.

The control is located in the front left corner of evaporator tub under the Display Deck Pan.

Note: Never change any of the other setting other than the refrigerant type. It may also be necessary to change the superheat setting only when using a different refrigerant.



Indicator lights	
	Red light - critical alarm (system is NOT running)
	Yellow light - non-critical alarm (system running)
	Green light - compressor on
	Green blinking - compressor waiting on timer to start/stop

Changing Refrigerant

- Access the set point mode by pressing and holding the **ENTER** button until Ctl displays on the screen.
- Use the **▲** up or **▼** down arrows to advance through the available set points until rFG displays on the screen and press the **ENTER** button.
- Use the **▲** up or **▼** down arrows until the desired refrigeration displays on the screen and press and hold the **ENTER** button until rFG once again displays on the screen.
- Press the **BACK** to return to escape the settings menu.

Changing Superheat

- Access the set point mode by pressing and holding the **ENTER** button until Ctl displays on the screen.
- Use the **▲** up or **▼** down arrows to advance through the available set points until SSP displays on the screen and press the **ENTER** button.
- Use the **▲** up or **▼** down arrows to set the desired superheat displays on the screen and press and hold the **ENTER** button until SSP once again displays on the screen.

Press the **BACK** to return to escape the settings menu.

5.2 EVAPORATOR CONDENSATE DRAIN TUBE



WARNING TO INSTALLER:

Evaporator Condensate Drain Tube may become dislodged during shipping. Installer must check Evaporator Condensate Drain Tube upon installation to be sure drain tube is properly seated and installed correctly.

Evaporator Drain Tube must be attached to tube protruding from bottom of Evaporator Tub and must either be inside the Condensate Pan area or inside of hole of Condensate Pump.

5.3 CONDENSATE PUMP

A condensate pump is Standard on some models and Optional on all models. Installer must check unit to see if a condensate pump has been provided with case.



WARNING TO INSTALLER:

Installer must determine if case was provided with condensate pump. Failure to hook up pump hose to drain will cause water on floor and cause a slip hazard.

Instead of using heat energy to remove condensate run off from the evaporator coil a condensate pump moves the water to a nearby drain.

- The Condensate Pump is provided with 50ft of clear 1/2in OD x 3/8in ID tubing that must be run out of the base area to a drain.
- There are several drain tube exit locations provided in the base as noted in the drawing above. Plugs or caps will need to be removed in the desired exit location.
- The hose can be run the entire 50ft in any direction as required, but no higher than 20ft from the pump base. A check valve is provided in the pump to prevent water from flowing back into the reservoir. For best efficiency extend the hose level below the level of the pump base to create a siphoning effect. Never run the hose to or through an area below freezing (32°F, 0°C) or freezing water will block the tube.

(6) INSTALLATION INSTRUCTIONS

6.1 LOCATING THE DISPLAY CASE

The case should be located where it is not subjected to the direct rays of the sun, heating ducts, grills, radiator, or ceiling fans, nor should it be located near open doors or main door entrances. Also, avoid locations where there are excessive air movement or air disturbances.

The case requires a minimum of 4 inches of clearance at the rear of the unit for air discharge. Do not locate case with back tight against the wall.

No clearance is needed on sides of the unit.

6.2 REMOVING CASE FROM SHIPPING SKID AND GENERAL INSTALLATION



CAUTION:

Do not push or pull against the top end glass, or door frames and do not pull on end panels when removing the case from the skid or moving the case. Case damage or glass breakage will result.

1. Remove crate top and sides and note missing or damaged items as explained in the pre-installation procedures outlined above.
2. Move the case as near as possible to the final location and before removing it from the shipping skid.
3. Remove the (4) brackets that secure the case to the shipping skid.
4. Prepare cabinet according to instructions in this section that pertain to your model.
5. Lift the case off of skid and into required position. Only lift the case from under the rear lip and front bottom trim channel above the base. Note: Do not push or pull on front bottom trim channel.
6. The case must be level for proper drainage of defrost condensate to the condensate evaporator. Using the wrench provided level and square the case as needed by adjusting the leg leveler in each corner of base. The 6ft cases also have a set of leg levelers in the center. These must be adjusted so the base is flat.
7. The leveled case must be sealed to the floor using a NSF listed sealant.

6.3 CLEANING

For initial setup, clean the case as outlined in the “Weekly Cleaning” section of this manual.

6.4 SSRVS33 UNDER COUNTER INSTALLATION

CASE TOP

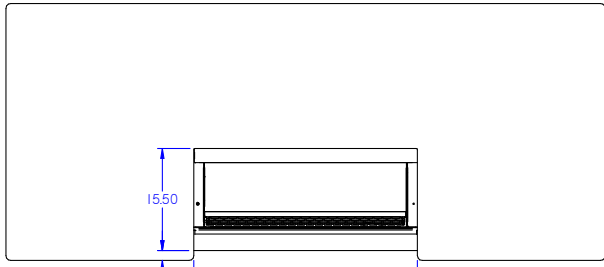

COUNTERTOP OVERHANG

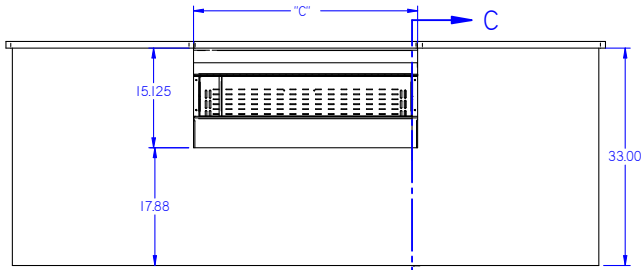

CASE FRONT

SECTION C-C

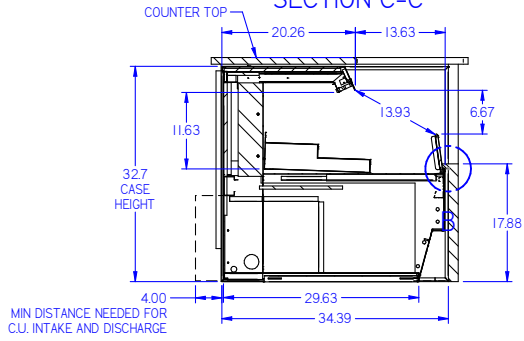

CASE	CASE LENGTH "A"	MINIMUM "B" DIMENSION	MINIMUM "C" DIMENSION
SSRVS3633	36"	37"	34"
SSRVS5033	50"	51"	48"
SSRVS5933	59"	60"	57"
SSRVS7733	77"	78"	76"

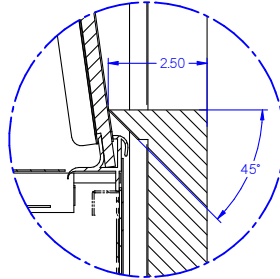
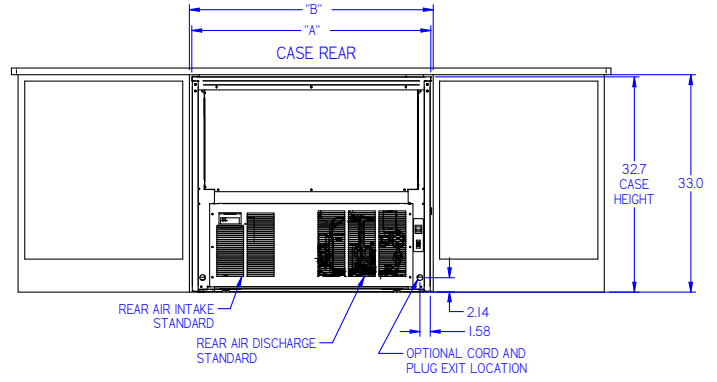

DETAIL B

_1642578330

(7) SHELVING INSTALLATION & REMOVAL

7.1 SHELF BRACKETS AND SUPPORTS INSTALLATION

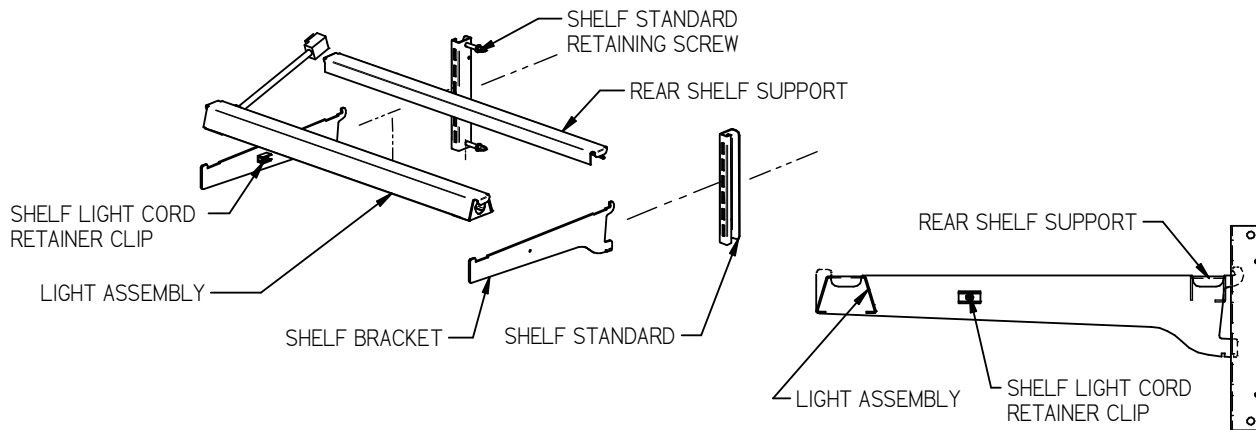

1. Turn the light switch to the off position.
2. Follow the instructions in the illustration below and insert (1) of the shelf brackets in the desired shelf standard slot on one side of the case. Place the additional bracket in the same shelf standard slot on the opposite end of case. The bracket with a clear plastic cord retainer clip must be on the side with the shelf light.

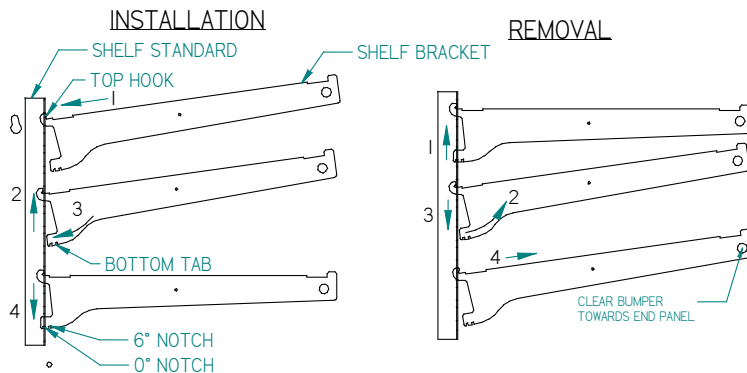

1. Place shelf bracket top hook into desired shelf standard slot.
2. Lift shelf bracket top hook to allow shelf bracket bottom tab to clear shelf standard slot.
3. Swing shelf bracket bottom tab into shelf standard slot.
4. Place the desired shelf bracket notch of 0, 6, or 12 degrees onto bottom of shelf standard slot.

1. Lift shelf bracket up to allow shelf bracket notch to clear the bottom of shelf standard slot.
2. Swing shelf bracket bottom tab out of shelf standard slot.
3. Drop shelf bracket down to allow shelf bracket top hook to clear top of shelf standard slot.
4. remove shelf bracket top from shelf standard slot.

3. Hang one end of the shelf light housing on the front notch of a shelf bracket and then the other end of the shelf light housing on the notch of the shelf bracket on the opposite end. Note: On models without shelf lights, use a shelf support instead of a shelf light housing.
4. Push shelf light cords into plastic shelf cord retainer clip located on the inside of the shelf bracket.
5. Remove the cap from the appropriate female light sockets. **Important:** Grip each side of cap firmly and wiggle and pull cap straight out of socket. Do not roll cap during removal. Incorrect removal of cap may cause damage to electrical connection

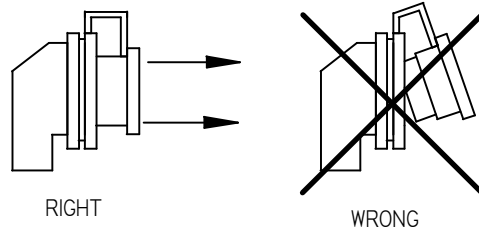

6. If the socket is not being used for a shelf light, the cap must be plugged into socket for entire light system to operate. On Models with the 5 pin shelf plug, this is necessary for the entire light system to operate. On models with the 3 pin shelf plug, this is necessary to prevent buildup and damage to the receptacle.
7. Plug in shelf light by aligning the male pins on the appropriate shelf light cord plugs with the female light sockets and push together. **IMPORTANT:** Do not roll plug during insertion.
8. Hang one end of the shelf support on to the rear notch of one shelf bracket and then on the rear notch of the shelf bracket on the opposite side.
9. Place supplied shelving onto shelf supports as outlined in the appropriate “Shelf Installation” section of this manual.
10. Removal of shelving is performed by following steps in reverse order.
11. The shelf standards are removable from case by removing the (2) shelf standard retaining screws holding them to the inside wall of case.

7.2 SOLID SHELF INSTALLATION

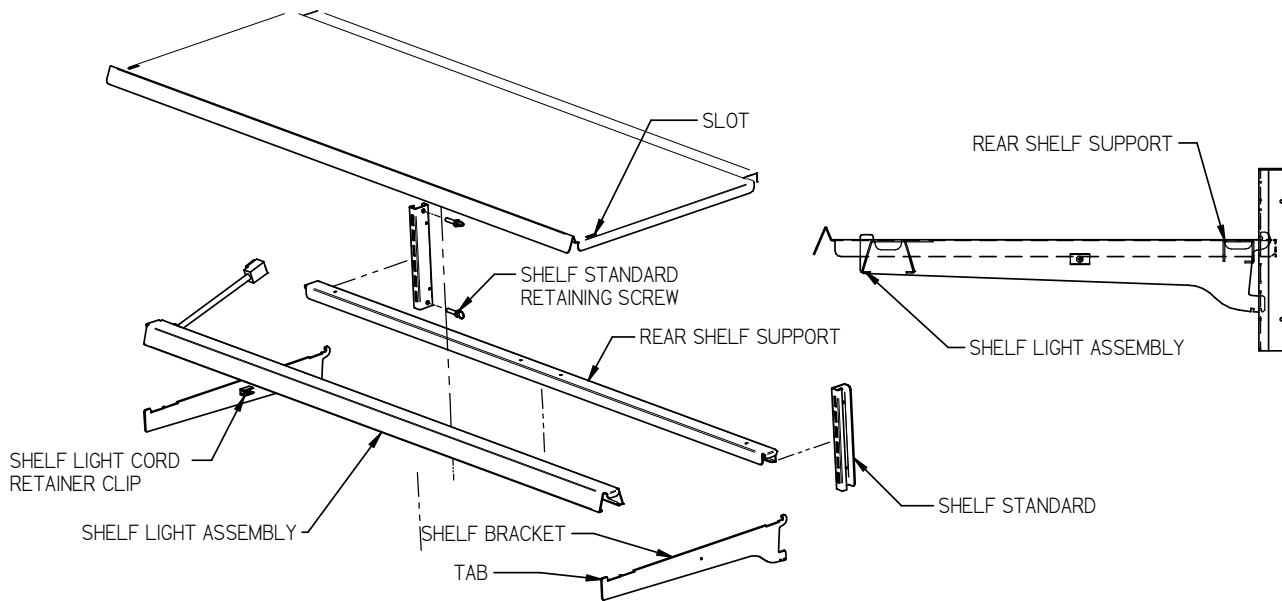

1. Install shelf brackets & shelf supports as described in Shelf Bracket & Supports Installation Section of this manual.
2. Place the front of metal shelf onto front shelf light. (On front shelf support for models without shelf lights). The tab on end of shelf bracket must go through slot in front of shelf.
3. Place the back of shelf over the back of the rear shelf support.

7.3 GLASS SHELF INSTALLATION (OPTIONAL)

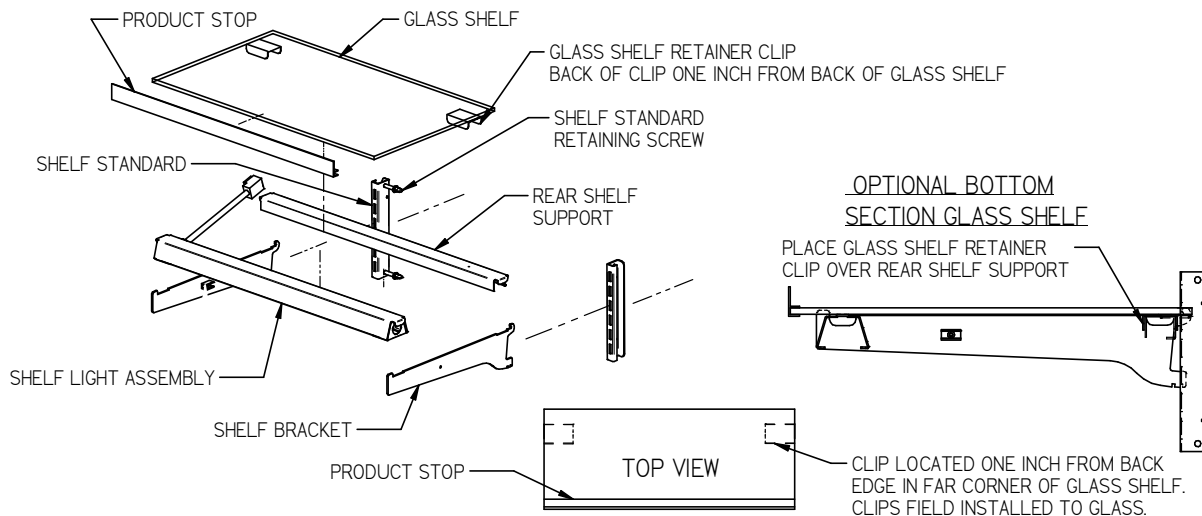

1. For first time installation attach (2) glass shelf retainer clips to each glass shelf in location shown in illustration one inch from back of glass as shown. Clean area of glass where glass shelf holder is to be located with rubbing alcohol and let air dry before installing shelf glass holder. Remove backing from tape located on flat side of glass shelf holder. Position the glass shelf holders in the (2) far corners of glass. Repeat for each glass shelf.
2. For first time installation attach (1) product stop to each glass shelf as shown in detail above. Align the product stop edge with the edge of the glass and push the “U” portion of the product stop on to glass lip across the entire front of glass.
3. Attach a clear bumper on both sides of the light housing top surface for the front of the glass to set on. This step may have already been performed at the factory for you.
4. Place front of glass shelf onto clear bumpers on front shelf light. (On front shelf support for models without shelf lights).

(8) SSRPF CASE REAR DOORS (OPTION)

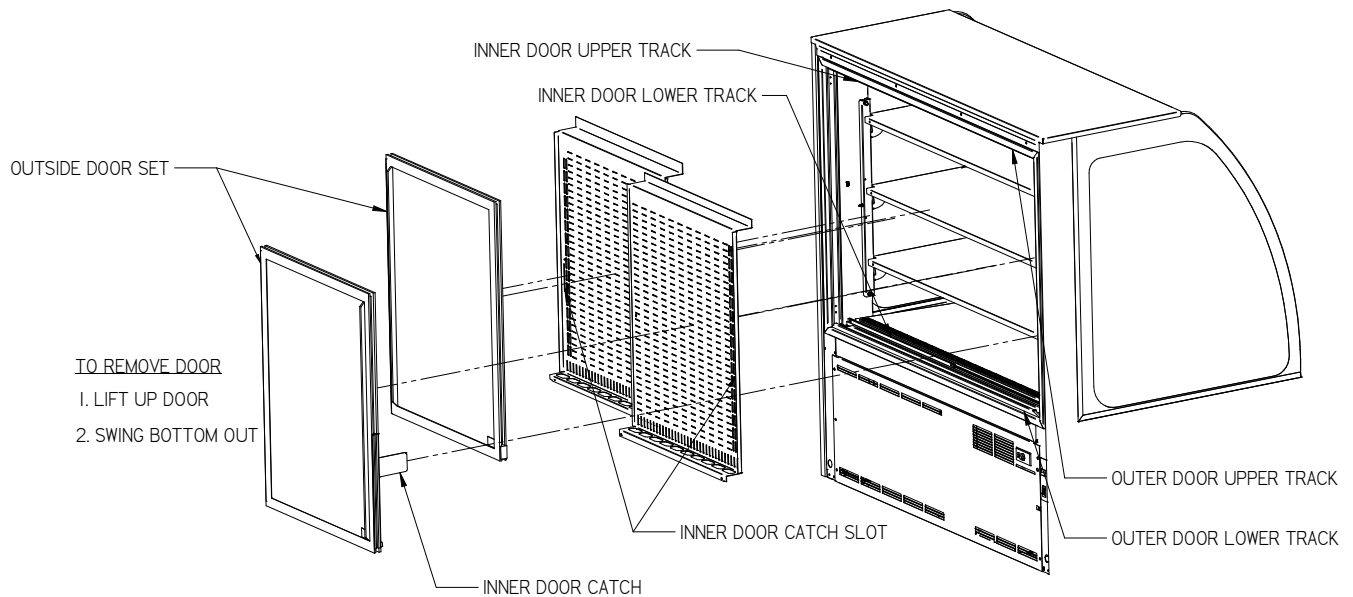

1. Start with the outer “outside door” and lift the door upward until the bottom edge of door clears the lower track and then swing the bottom of the door outward and down and out of upper track.
2. Remove the outer “inside door” using the same procedure.
3. The inner door set can then be removed using the same procedure starting with the inner “outside door” followed by the inner “inside door”.
4. Reverse this procedure for door reinstallation starting with the inner “inside door” followed by the inner “outside door”. Check that all the doors slide freely.
5. Replace the outside “inner door” and the outside “outer door”. Be sure to slide the inner door catch into the inner door catch slot for each left and right side door.

Note: All four rear doors are “not” interchangeable. Each rear door must be replaced in each doors original location.

(9) NIGHT CURTAIN OPERATION

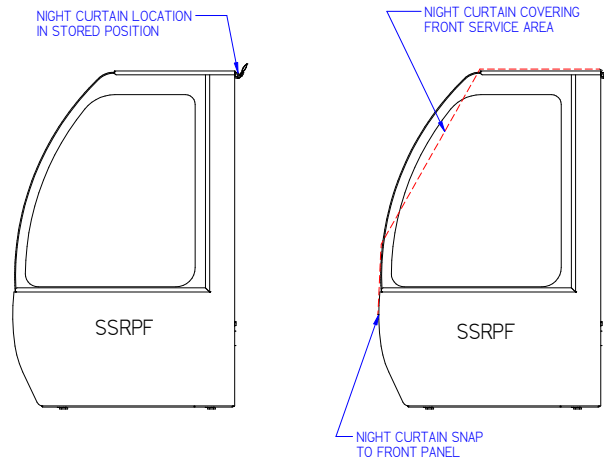

The night curtain rolls up and is stored on the back top edge of the case as shown in first view. The curtain can be used to cover the front open display area as shown in the second view above.

OPENING SSRPF NIGHT CURTAIN:

Standing in back of the case, grab the night curtain strap and pull the rolled night curtain up and over the top and front of the case. Attach the snap located under the night curtain strap on to the snap located on the case front lower panel

CLOSING SSRPF NIGHT CURTAIN:

From front of case grab the night curtain strap and detach the snap located in the case front lower panel. Allow the night curtain to roll up over the top and back of the case. **Note:** The 59" and 77" models have (2) night curtains.

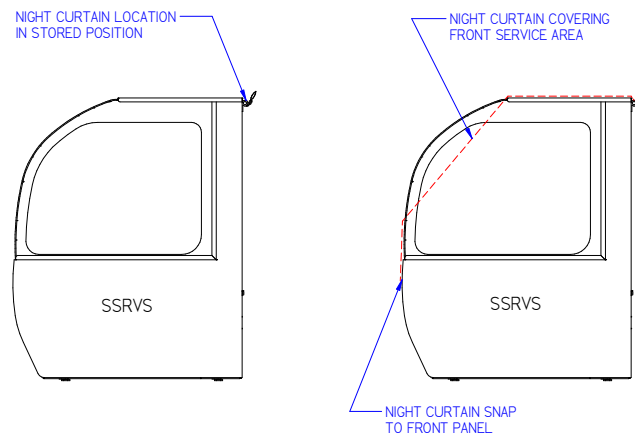

OPENING SSRVS NIGHT CURTAIN:

Standing in back of the case, grab the night curtain strap and pull the rolled night curtain up and over the top and front of the case. Attach the snap located under the night curtain strap on to the snap located on the case front lower panel

CLOSING SSRVS NIGHT CURTAIN:

From front of case grab the night curtain strap and detach the snap located in the case front lower panel. Allow the night curtain to roll up over the top and back of the case.

Note: The 59" and 77" models have (2) night curtains.

(10) SECURITY NIGHT COVER (OPTION)

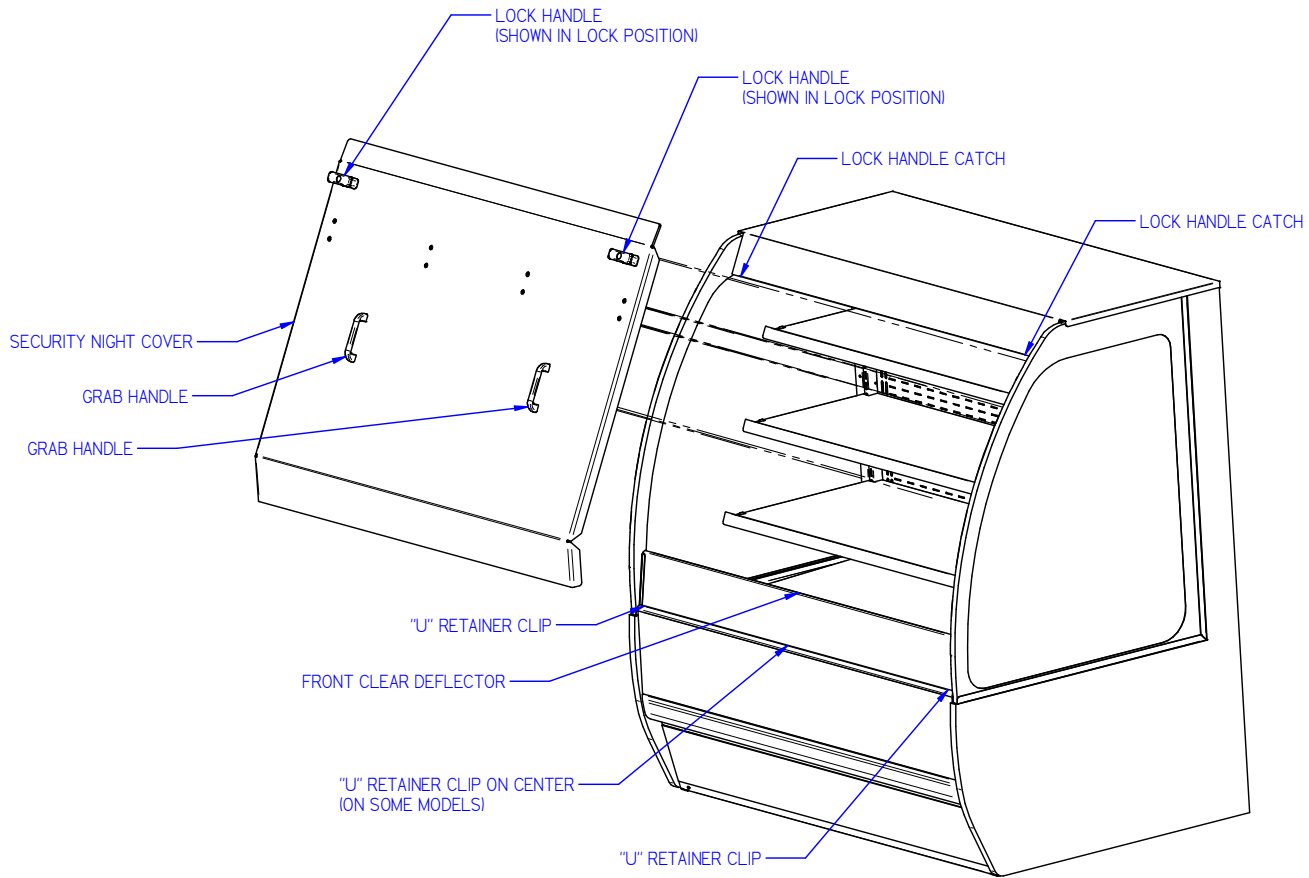

REMOVAL:

9. Unlock the lock handles and turn handles vertical to disengage from lock handle catches.
10. Grab the front grab handles and lift the cover straight up out of the case opening.

INSTALLATION:

1. Turn the lock handle so the latch handle is vertical to the top of the case.
2. Holding the grab handles place the bottom flange of the security night cover inside the "U" retainer clips located on each side of case opening behind the front clear deflector. There also may be a "U" retainer clip in the center of the case that must also engage the security night cover flange.
3. Set the top flange of the security cover down against the top glass handle.
4. Turn the lock handles so they engage the lock handle catches and use the key to lock them in place.

IMPORTANT: Cleaning the Acrylic plastic security night cover require special care to prevent hazing of material. Lightly dust (not wipe) the surface with clean soft cloth. Then the surface can be wiped carefully with a soft, wet cloth or chamois. The cloth or chamois must be kept free of grit by frequently rinsing in clean water. Grease and oil can be removed with kerosene. Do not use window cleaners or kitchen scouring compounds. **DO NOT** use solvents such as Acetone, Benzene, Carbon Tetrachloride, and Lacquer Thinners. A spray wax such as Pledge or Maguire's polish can be applied and wiped with a clean soft cloth. The wax tends to fill in and hide small scratches.

(11) OPERATING INSTRUCTIONS

11.1 USER CONTROLS OVERVIEW

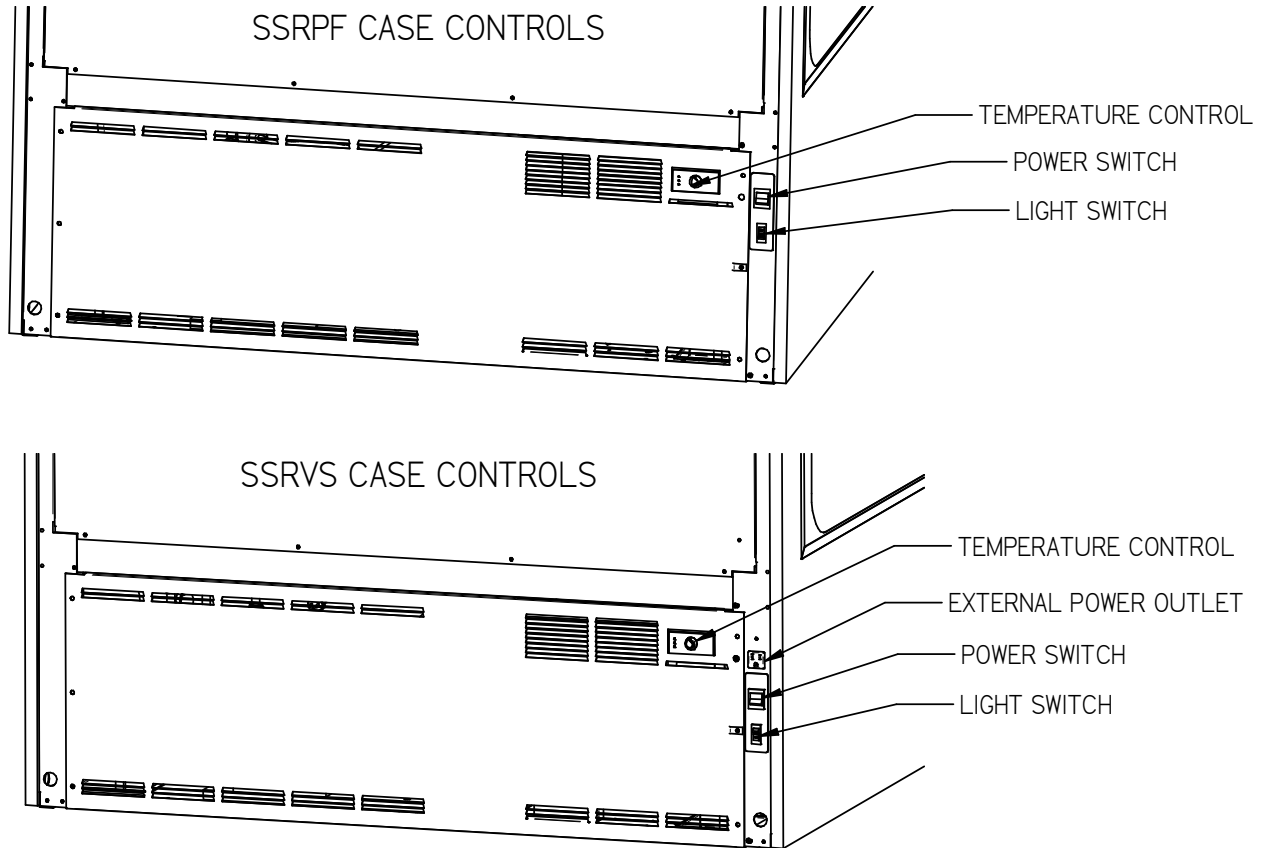

11.2 POWER SWITCH

The unit has a power switch that turns off power to the entire unit, including the condensate evaporator and the lights.

11.3 LIGHT SWITCH

The unit has a light switch that turns on and off the interior lights of unit.

11.4 ELECTRONIC TEMPERATURE CONTROL

Located in the rear grille of the display case, the temperature control allows the user to adjust the temperature of the display merchandiser to their needs.

11.4.1 Button and Display overview

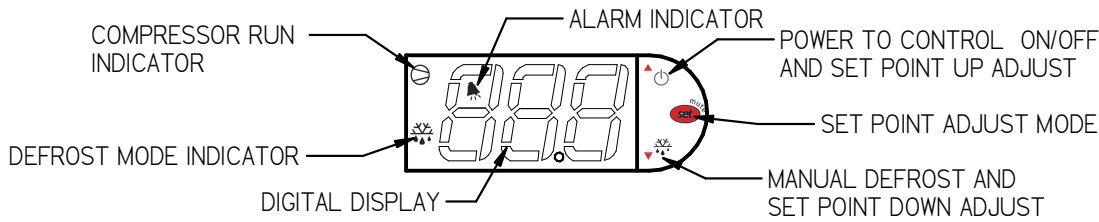

Button Overview

	Press and hold this button for three seconds to turn system on (if off) or off (if on). Also used to adjust set point when in set point adjust mode
	Press to enter set point adjust mode, confirm set point changes, and mute alarms.
	Press and hold this button for three seconds to initiate a manual defrost (and cancel defrost if initiated), also adjusts set point down when in set point adjust mode

11.4.2 Powering on control

To turn refrigeration control power on, press and hold for approx. three seconds. The display will read “On” while the button is depressed. When the control powers on, the display will read the current set point (a number “1” thru “9”). The compressor run indicator will illuminate on the display, meaning that the compressor is running. (Note: the control may already be in the on mode when shipped from factory).

To turn refrigeration control power to off, press and hold for approx. three seconds. The display will read “Off” while the button is depressed. When the control powers off the display will flash back and forth between the relative current case temperature and “Off”. The compressor run indicator will be off on the display. When refrigeration control is in the off-mode cabinet lights and evaporator fans will still operate, but the compressor will not turn on causing the case to gradually reach room temperature.





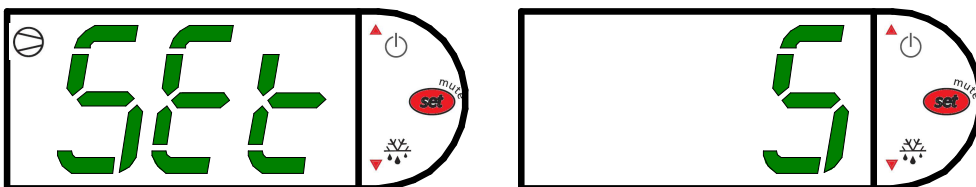

11.4.3 Adjusting the set point

The set point is what determines how cold the display case will hold food and beverage. To adjust the set point press and hold the button approx. three seconds until the display begins to flash a number. Then press the use the button to scroll number up (colder) or press the button to scroll number lower (warmer). There are nine (9) available set points numbers, the higher the number of the set point, the colder the display case will run, with setting “9” being the coldest and setting “1” being the warmest. Once you have chosen your desired setting press the button again to confirm your choice.



11.4.4 Entering Manual Defrost Mode

In order to initiate a manual, defrost press and hold the  button approx. three seconds. The control will read “dEF” while the button is being held. The defrost is initiated when the defrost mode indicator  illuminates on the display. The control display will then return to reading the case temperature. When the defrost mode indicator  turns off the defrost is complete and the compressor will turn back on illuminating the compressor run indicator .



11.4.5 Error codes

It is possible for error codes to be displayed on the control screen. In the event of a malfunction an alarm will sound and the alarm indicator  will be displayed on the display. An error code or codes will flash intermittently on the display. If there are multiple codes, the display will continuously cycle through them. The following photo shows error code “E0” as an example.



Mute: You may mute the alarm by pressing and releasing the wrench button. The red ringing bell and all error codes will still be displayed. When the fault is remedied the control will return to normal operation and will automatically clear the codes from the display.

E0 = Air sensing probe - Open or shorted

E1 = Evap. coil probe - Open or shorted

Error codes may be encountered if either the controller or the display case is malfunctioning. The following is a list of error codes that may be encountered.

Table 1 - Error Codes and Resolutions

Code	Description	Cause	Resolution
E0	Temperature probe error	Probe signal is interrupted or short-circuited	Check to ensure probe wires and quick disconnect are secure in control. Check probe resistance to table below. If 0 resistance is present check wiring insulation. If infinite resistance is present check for breaks in wiring (meter will likely read overload or very high in the mega-ohm range). Ensure that probes are wired per the wiring diagram provided. Replace probe if other remedies fail, or if probe resistance deviates from “ ” below
E1	Defrost probe error	See E0	
EE	Unit parameter reading error	Operating conditions	Remedy abnormal operating conditions. The control is rated to operate in a range of 14 to 122°F (-10 to 50°C) and less than 90%RH non-condensing. Replace control if problem persists.
EF	Operating parameter reading error	See EE	

11.5 ELECTRONIC CONTROL OPERATION

This unit is equipped with an electronic temperature control. The control parameters are set at the factory and cannot be manually changed in the field. The pre set control parameters are listed on the chart in the Settings Chart below.

Operation

The control uses two sensors, one located in the air stream and one located on the evaporator coil. The sensor located in the air stream is referred to as the temperature control sensor. The sensor located on the evaporator coil is referred to as the defrost probe.

The temperature control sensor is located on the plastic tub behind the evaporator coil to the left in the cold air stream. The sensor location is critical for proper operation on the unit. Do not move or relocate this sensor.

The coil sensor is strapped to the evaporator coil. This sensor location is critical for proper operation of the unit. Do not move or relocate this sensor.

The temperature control is set to cut in at 39°F (3.9°C). The Temp control cuts out at 26°F (-3.3°C) at the coldest setting “9” and 36°F (2.2°C) at the warmest setting “1”.

See “**Error! Reference source not found.**” on page **Error! Bookmark not defined.** for more details on using the control.

Defrost Cycle

The control is programmed to initiate defrost via two different methods. There are 3 programmed defrost cycles in the case which will initiate a defrost cycle every 8 hours. The unit does not have a time clock so the defrost cycles cannot be set for any specific time of day.

The unit also has an ‘On demand’ defrost feature that will initiate a defrost when the temperature differential between the evaporator temperature and the air temperature is more than 20°F (11.1°C) for 5 minutes after 30 minutes into the refrigeration cycle (e.g. if the air stream probe measures 42°F/5.6°C or greater and the defrost probe measures 20°F/-6.7°C or lower for five minutes). Once initiated the defrost cycle will terminate when evaporator coil sensor reaches 43°F (6.1°C).

If a manual defrost is required, one can be initiated by pressing and holding the down arrow for three (3) seconds. This is typically unnecessary and should only be performed if special circumstances require it.

11.6 CONTROL PARAMETERS

Table 2 - Control Parameters

Parameter Description SSRPF52,SRVS42									
Control Setpoint →	1	2	3	4	5	6	7	8	9
Compressor Cut out [°F]	36.0	34.7	33.5	32.2	31.0	29.7	28.5	27.2	26.0
Compressor Cut in [°F]	39.0°								
Compressor Min On Time	10 min (5 MIN ON SSRVS33)								
Compressor Min Off Time	3 min								
Compressor Max Run Time	90 min								
Defrost Termination Temp [°F]	43.0								
Time to first defrost	8 hr.								
Time to subsequent defrost	8 hr.								
Maximum Defrost duration	30 min								
Defrost on demand differential [°F]	26.0 (25.0 MIN ON SSRVS33)								
Delay for defrost on demand	5 min								
Time delay to the next defrost on demand	30 min								

Table 3 - Temperature Probe Common Resistance Chart

Probe Temp	Maximum Resistance [Ω]	Normal Resistance [Ω]	Minimum Resistance [Ω]
32°F (0°C)	27.83	27.28	26.74
77°F (25°C)	10.1	10	9.9
212°F (100°C)	1	0.97	0.94

11.7 INITIAL STARTUP

After all the checks outlined in the installation section of this manual have been made, the case is ready to be put into service. Turn on the Power at the breaker box and flip the Power Switch and Light Switch on unit to the on position. Also ensure that the control is powered on as described above in “**Error! Reference source not found.**”.

At start up from a warm unit, it is recommended that the temperature control is set to a warmer setting, such as 1. After the unit has gone through several cycles, adjust the control to a mid-range setting, then to a colder setting if necessary to maintain desired product temperature

	<p>NOTICE: This refrigerated display case is designed to operate in a maximum environment of 75°F (23.9°C) and 55% relative humidity. Exceeding these limits will cause poor case performance and excessive sweating.</p>
---	---

11.8 PLACING PRODUCT IN CASE

- Do not exceed weight limits shown in the table below when loading product into the display case.

Table 4 - Shelf Loading Limits

Model	Top Shelf	Middle Shelf	Bottom Shelf	Display Deck
SSRPF/VS36	80lbs (36kg)	100lbs (45kg)	120lbs (55kg)	165lbs (75kg)
SSRPF/VS50	120lbs (55kg)	140lbs (64kg)	170lbs (77kg)	240lbs (109kg)
SSRPF/VS59	140lbs (64kg)	170lbs (77kg)	210lbs (95kg)	290lbs (132kg)
SSRPF/VS77	180lbs (82kg)	230lbs (105kg)	270lbs (123kg)	390lbs (177kg)

- Determine desired shelving location before placing product in case. Product must be removed to readjust shelf location and angle.
- Do not overhang the front or rear of shelves with product. Improper clearance in front and rear of shelf will block the refrigerated air flow and will cause product loss.
- Do not block the slots along the front and rear air discharge slots. Covering these slots will block the refrigerated air flow and will cause product loss.
- The display deck is removable for cleaning and can become dislodged in shipment. To ensure proper airflow and performance of the case, make sure that the display deck is pushed completely down into the plastic evaporator tub.
- Allow refrigerated models to run for at least two hours before placing pre-chilled product into unit.

	<p>NOTICE: Case must be stocked with pre-chilled product only. Product should be at or below 40°F (4.5°C) before adding it to the display case. Use a refrigerator to pull down product that is above 40°F (4.5°C). This display case is a temperature <i>holding</i> product only. It <i>will not</i> pull down product that is above the recommended temperature.</p>
---	---

(12) MAINTENANCE (LIGHTS)

Top Light Bulb Replacement, Fluorescent 12/1/19

1. To remove bulb from top light housing, grip the bulb receptacle end caps at each end of bulb. Pull the bulb receptacle end caps straight outward away from unit.
2. The bulb is inside a clear shatterproof tube with a white plastic end cap on each end. Be careful not to allow the bulb to slide out of the shatterproof tube.
3. Reinstall new bulb in to the existing shatter proof tube and reuse white plastic end caps.
4. Reinstall new bulb assembly in the same manner as described in the Bulb Removal Procedure. Be sure bulb is secure in bulb receptacles. **Note: Be sure to use a direct equivalent to the original bulb.**

Shelf Light Bulb Replacement, Fluorescent 12/1/19

1. All shelf light fixtures use a spring-loaded socket at one end. To remove the bulb, push the bulb towards the spring-loaded socket until the opposite ends drops out of the socket.
2. The bulb is inside a clear shatterproof tube with a black plastic cap on each end. Be careful not to allow bulb to slide out of shatterproof tube.
3. Reinstall new bulb in to the existing shatterproof tube and reuse black plastic end caps. Reinstall bulb assembly in the same manner as described in the Bulb Removal Procedure. Be sure bulb is secure in bulb receptacles. **Note: Be sure to use a direct equivalent to the original bulb.**

Top/Ceiling Light Bulb Replacement, LED (Cases Manufactured after 12/01/19)

1. Turn power switch on rear of case to “off.”
2. Disconnect light cord barrel plug from receptacle in LED by pulling barrel plug straight out.
3. The LED is attached to clips mounted to the ceiling or top light housing. Disengage the LED from the clips.
4. Attach the new LED to the clips on the ceiling. Be sure that the LED is centered about the clips.

Shelf Light Bulb Replacement, LED (Cases Manufactured after 12/01/19)

1. Turn power switch on rear of case to “off.”
2. Disconnect light cord barrel plug from receptacle in LED by pulling barrel plug straight out.
3. The LED is adhered to the front shelf support with double-sided tape. It may be necessary to use a razor blade to detach the LED from the top light housing. **NOTE: TAKE CARE NOT TO DAMAGE THE FINISH ON THE FRONT SHELF SUPPORT.**
4. Remove the remaining double-sided tape from the **FRONT SHELF SUPPORT.**
5. Apply a new layer of double sided tape to the new LED and adhere to the front shelf support. Locate new LED by centering between (2) .09 dia holes on the front shelf support.

(13) PERIODIC MAINTENANCE (CLEAN CONDENSER)

Cleaning Condenser Coil (All Self Contained Refrigerated Models)



NOTICE:

Condenser coil must be cleaned a minimum of twice per month to insure proper refrigeration performance and prevent compressor failure. In some environments, it may be necessary to clean more frequently. **FAILURE TO CLEAN CONDENSER COIL WILL VOID COMPRESSOR WARRANTY.**

It is very important that the condenser coil is cleaned twice per month to ensure proper refrigeration performance and to prevent compressor failure. Failure to clean condenser coil will void condenser warranty.

1. Disconnect power to the unit
2. Remove the rear base panel located on the back of the unit by removing the rear panel retaining screws.
3. Carefully vacuum the front surface of condenser coil. Take care not to bend coil fins with vacuum cleaner nozzle. A brush attachment works well to prevent this.
4. Reinstall rear panel and retaining screws.

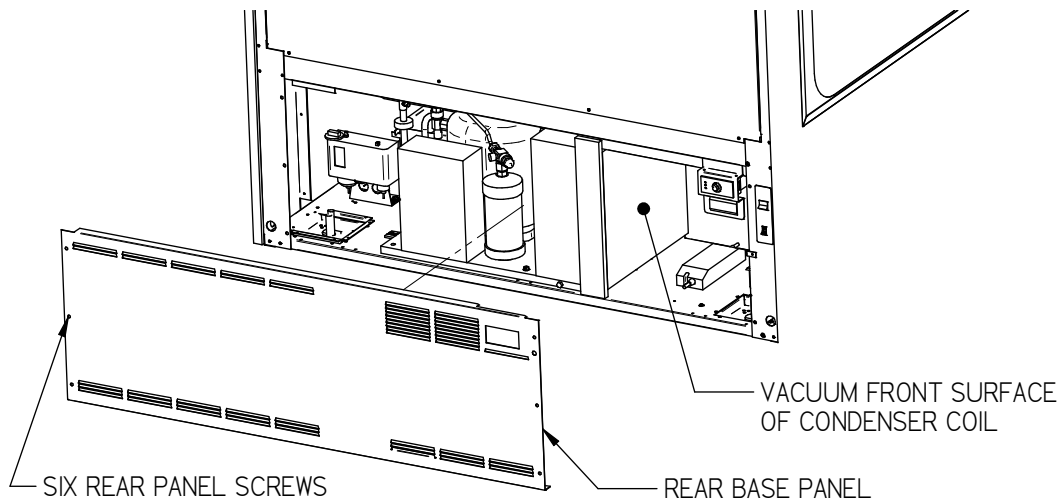







Figure 2 - Condenser Cleaning

(14) CLEANING INSTRUCTIONS

14.1 DAILY CLEANING

The case should be cleaned thoroughly, as described in the weekly cleaning section, before it is used for the first time.

	NOTICE: Avoid splashing or soaking any electrical components with water to prevent electrical damage to the case.
	NOTICE: Shut off lights and power switches and remove all product from case. Allow sufficient time for the unit to reach room temperature before proceeding with cleaning.
	NOTICE: Remove all product from case before proceeding with cleaning procedure.
	NOTICE: Acrylic front air deflector requires special washing procedures to prevent hazing and yellowing of material.
	NOTICE: This case is not designed to be cleaned by flushing.

Note: For major spills or foreign material buildup perform the weekly cleaning instructions.



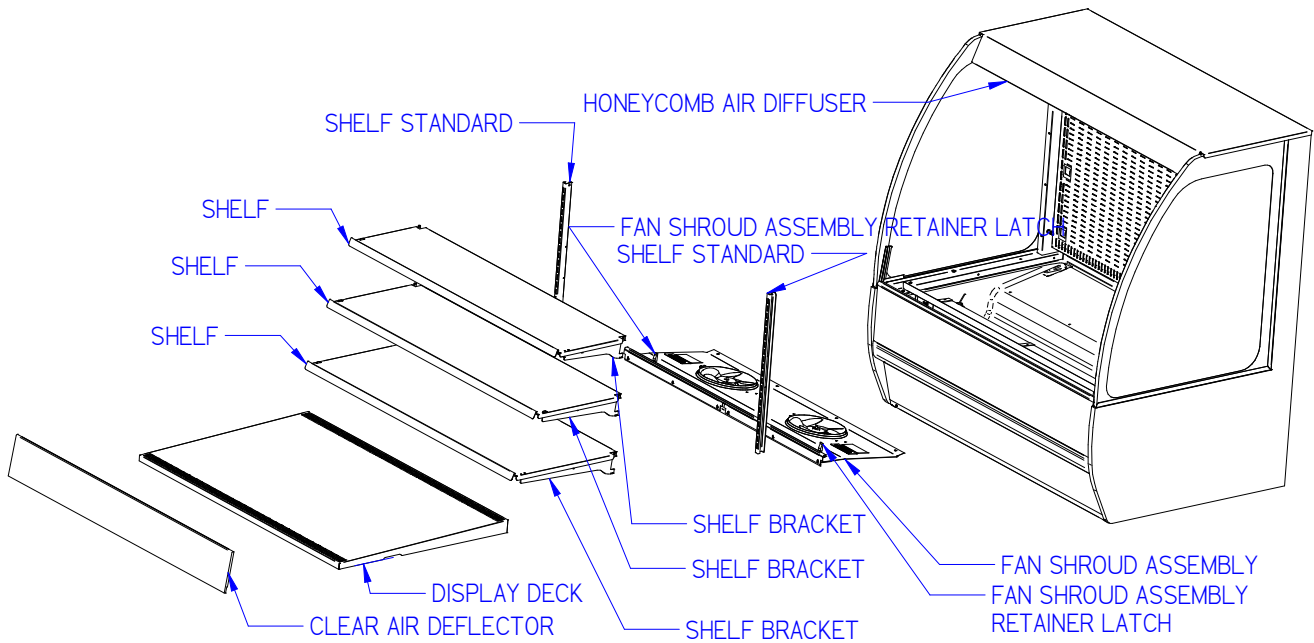

Note: Detergents are not recommended and do not use abrasive cleaners or pads to prevent scratching of surfaces.

1. Clean all foreign materials from the door opening if supplied.
2. Wipe complete interior of both the upper & lower areas of case using a damp cloth.
3. The remaining exterior surface should be wiped down using any ammoniated cleaners or soapy warm water.
4. **IMPORTANT:** Cleaning the clear acrylic plastic front air deflector require special care to prevent hazing and yellowing of material. Lightly dust (not wipe) surface with clean soft cloth. Then the surface can be wiped carefully with a soft, wet cloth or chamois. The cloth or chamois must be kept free of grit by frequently rinsing in clean water. Grease and oil can be removed with kerosene. Do not use window cleaners or kitchen scouring compounds. **DO NOT** use solvents such as Acetone, Benzene, Carbon Tetrachloride, and Lacquer Thinners. A spray wax such as Pledge or Maguire's polish can be applied and wiped with a clean soft cloth. The wax tends to fill in and hide small scratches.

14.2 WEEKLY CLEANING



This procedure is recommended on a weekly basis. It may need to be performed more often if necessary to maintain a clean, sanitary case. The case should be cleaned to this procedure before using the first time.

	<p>NOTICE: Avoid splashing or soaking any electrical components with water to prevent electrical damage to the case.</p>
	<p>NOTICE: Shut off lights and power switches and remove all product from case. Allow sufficient time for the unit to reach room temperature before proceeding with cleaning.</p>
	<p>NOTICE: Remove all product from case before proceeding with cleaning procedure.</p>
	<p>NOTICE: This case is not designed to be cleaned by flushing.</p>

1. The side glass can be cleaned with common window cleaners.
2. Remove food pan catch tray by lifting it out of top of case. Clean all foreign material from around and under the food pan catch tray. Clean food pan catch tray using warm soapy water and a brush.
3. If supplied with Rear Door Option, remove both inner & outer rear doors as described in the “Door Removal” section of this manual.
4. Clean all foreign material from inner and outer rear door tracks and clean both sides of the doors using warm soapy water and a brush. Apply a light film of lubricant such as PAM to door tracks to make the doors operate smoother.
5. Remove interior shelving from unit as described in the “Shelving Installation and Removal” section of this manual. Remove both shelf standards from interior of case by removing the (2) thumbscrew from top and bottom of each standard.
6. Clean all shelves, shelf supports, shelf light housings, shelf brackets, shelf standards using warm soapy water and a brush. Rinse thoroughly and allow to dry.

7. Lift the display deck(s) up and out of evaporator tub.
8. Remove the fan shroud assembly by lifting (2) black tabs up on fan shroud assembly retainer latch at each end of the front of the fan shroud and removing the thumb screws from along the rear lip of the fan shroud. Lift the fan shroud assembly and reach in and unplug the evaporator fan motor cord(s). Lift fan shroud assembly out of tub.
9. Clean the display deck(s) using warm soapy water and a brush. Rinse thoroughly and allow to dry. Wipe off fan shroud assembly (do not rinse or submerge fan motors).
10. Clean the entire interior of the case using warm soapy water. Flush foreign material from drain area. Wipe off all soapy water with a damp cloth and allow to dry. (DO NOT use solvents such as Acetone, Benzene, Carbon Tetrachloride, and Lacquer Thinners)
11. Remove the honeycomb air diffuser(s) from upper air duct track. Loosen thumb screws on Retainer located behind diffuser. Retainer will drop down allowing diffuser to be pulled out of case.

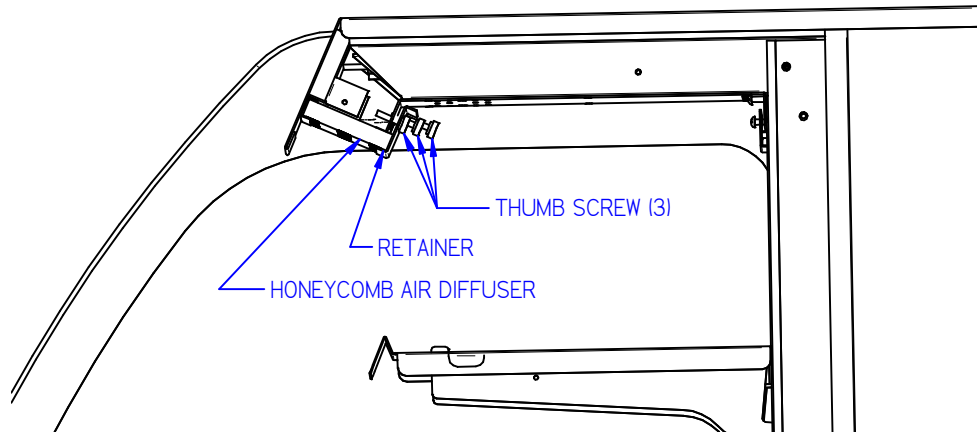

12. Clean honey comb air diffuser with warm soapy water and a brush. Rinse thoroughly and allow to dry.
13. Remove the clear plastic front air deflector by lifting it up and out of case.
IMPORTANT: Cleaning the Acrylic plastic front air deflector require special care to prevent hazing and yellowing of material. Lightly dust (not wipe) the surface with a clean soft cloth. Then the surface can be wiped carefully with a soft, wet cloth or chamois. The cloth or chamois must be kept free of grit by frequently rinsing in clean water. Grease and oil can be removed with kerosene. Do not use window cleaners or kitchen scouring compounds. DO NOT use solvents such as Acetone, Benzene, Carbon Tetrachloride, and Lacquer Thinners. A spray wax such as Pledge or Maguire's polish can be applied and wiped with a clean soft cloth. The wax tends to fill in and hide small scratches.
14. Reassemble all components in reverse order.
NOTE: Depending on the amount of usage and spillage of foreign material, some fasteners may have to be removed and parts disassembled to allow proper cleaning of the unit.

14.3 WEEKLY EXTERIOR CLEANING

1. Clean the front and end glass using any common window cleaner.
2. The exterior surfaces should be wiped down using any ammoniated cleansers or warm soapy water.

(15) SALE & DISPOSAL

15.1 OWNER RESPONSIBILITY

If you sell or give away your Federal Industries case you must make sure that all safety labels and the Installation-Service Manual are included with it. If you need replacement labels or manuals, Federal Industries will provide them free of charge. Contact the customer service department at Federal Industries at (800) 3564206.

The customer service department at Federal Industries should be contacted at the time of sale or disposal of your case so records may be kept of its new location.

If you sell or give away your Federal Industries case and you evacuate the refrigerant charge before shipment. Federal Industries recommends that the charge be evacuated into a recovery system to prevent the possibility of HFO's from being released into the atmosphere.

(16) SERVICE INFORMATION

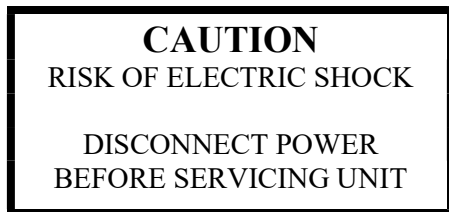

**Before any service work is performed
on the case, make sure all power is
disconnected to the case.**

To find a service company in your area, please visit our website at www.federalindustries.com. There you can also find self-service tools to help you get the answers you need faster!

For Warranty Service Requests & ALL Technical Support please contact:

- **Phone:** (800) 356-4206 and choose the Tech Support/Warranty Option
- **Email:** Service@federalind.com

For Warranty Compressors please contact the Parts Department:

- **Phone:** (800) 356-4206 and choose the Warranty Parts Option
- **Email:** Parts@Federalind.com



Federal Industries has partnered with Parts Town for ALL Non-Warranty Part Identification, Pricing, Lead Times, Orders & Freight Quotes. Please contact Parts Town directly if you need parts:

- **Website:** PartsTown.com
- **Email:** CustomerService@PartsTown.com
- **Phone:** 833-809-8188

16.1 SPECIAL SERVICE INSTRUCTIONS

There are rare occasions when the refrigerant charge must be evacuated from a case in order to perform service work. In those situations, Federal Industries recommends that the refrigerant charge be evacuated into a recovery system to prevent the possibility of hydrofluoro olefin (HFO's) from being released into the atmosphere.

If moisture or liquid is observed around or under a Federal Industries case, an immediate investigation should be made by qualified personnel to determine the source of the moisture or liquid. The investigation made should determine if the case is malfunctioning or if there is a simple housekeeping problem.

Moisture or liquid around or under a case is a potential slip/fall hazard for persons walking by or working in the general area of the case. Any case malfunction or housekeeping problem that creates a slip/fall hazard around or under a case should be corrected immediately.

16.2 PRE-SERVICE CHECKLIST

You may avoid the cost and inconvenience of an unnecessary service call by first reviewing this checklist of frequently encountered situations that can cause unsatisfactory case performance.

	CAUTION: Before servicing case, turn off power at the main breaker of fuse box.
---	--

Case does not operate

- Check for disconnected power supply.
- Check for tripped breaker or blown fuse.
- Check that power switch is on.

Lights do not operate

- Check that light switch is on.
- Shelf light: Check that shelf light cords are tight in the sockets and LEDs.
- Shelf light: Ensure all open sockets are filled with either shelf light cord plugs or dummy caps attached to socket.

Case temperature too warm (product is exceeding 41°F)

- Check that the cold air inlet and outlet slots are not blocked.
- If supplied with rear door option be sure that the rear doors are closed and tightly sealed
- Check for blocked or dirty condenser coil fins and clean them (see "0 Cleaning Condenser Coil (All Self Contained Refrigerated Models))

NOTICE:	Condenser coil must be cleaned a minimum of twice per month to insure proper refrigeration performance and prevent compressor failure. In some environments, it may be necessary to clean more frequently. FAILURE TO CLEAN CONDENSER COIL WILL VOID COMPRESSOR WARRANTY.
----------------	--

- ” page 26).
- Check that there is no paper or foreign material blocking the evaporator, and if so remove it.
- If the evaporator coil is blocked due to excessive frost, activate manual defrost mode on the electronic control.
- Check that the case is given the proper clearance behind the rear grille (see section 6.1 “Locating the Display Case” page 12)
- Check that there is no air movement around case causing disruption to the air curtain. Such as ceiling fans, heating/AC air ducts, exterior doors, etc.

(17) WIRING DIAGRAMS

E555-1 EXCEL

17.1 SELF CONTAINED (MFG'D BEFORE 1/1/19)

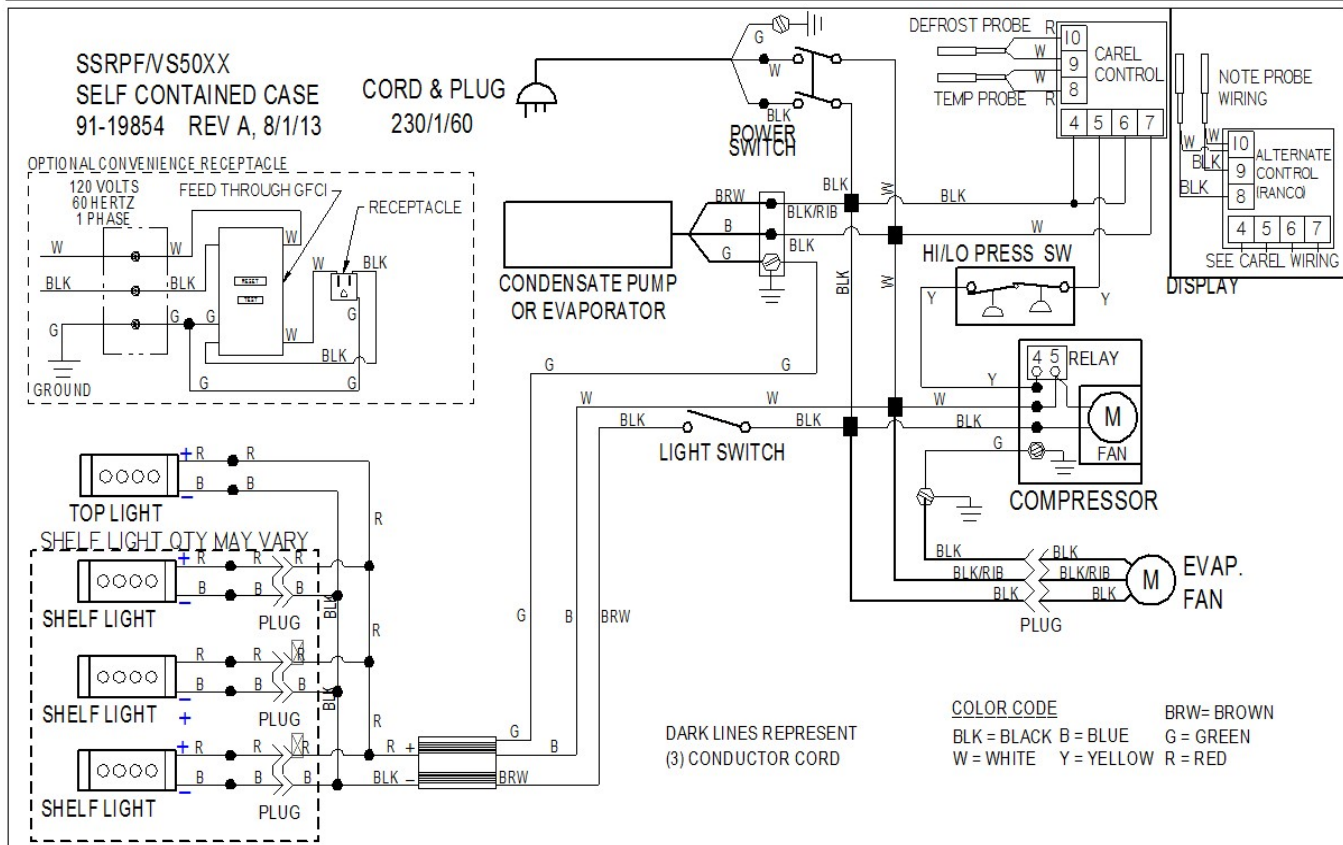
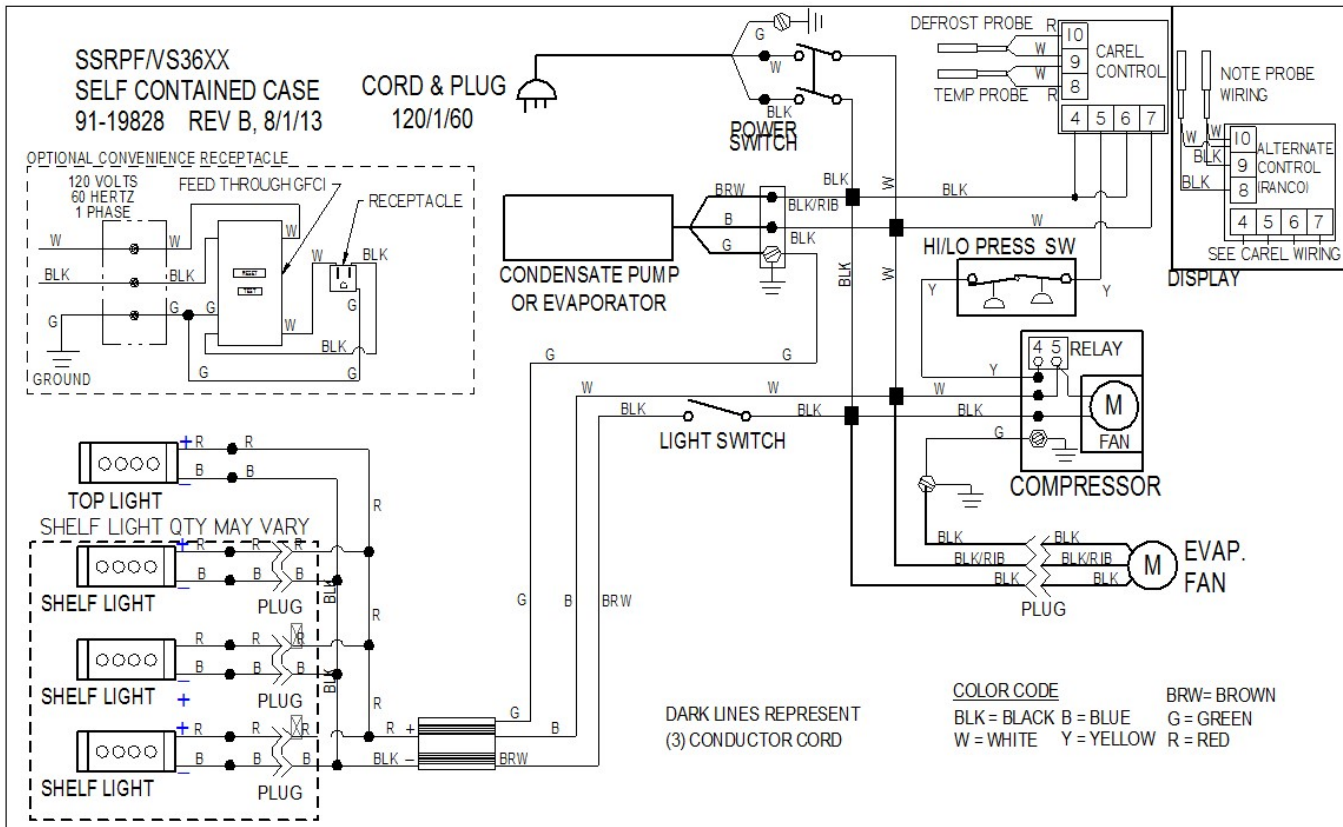

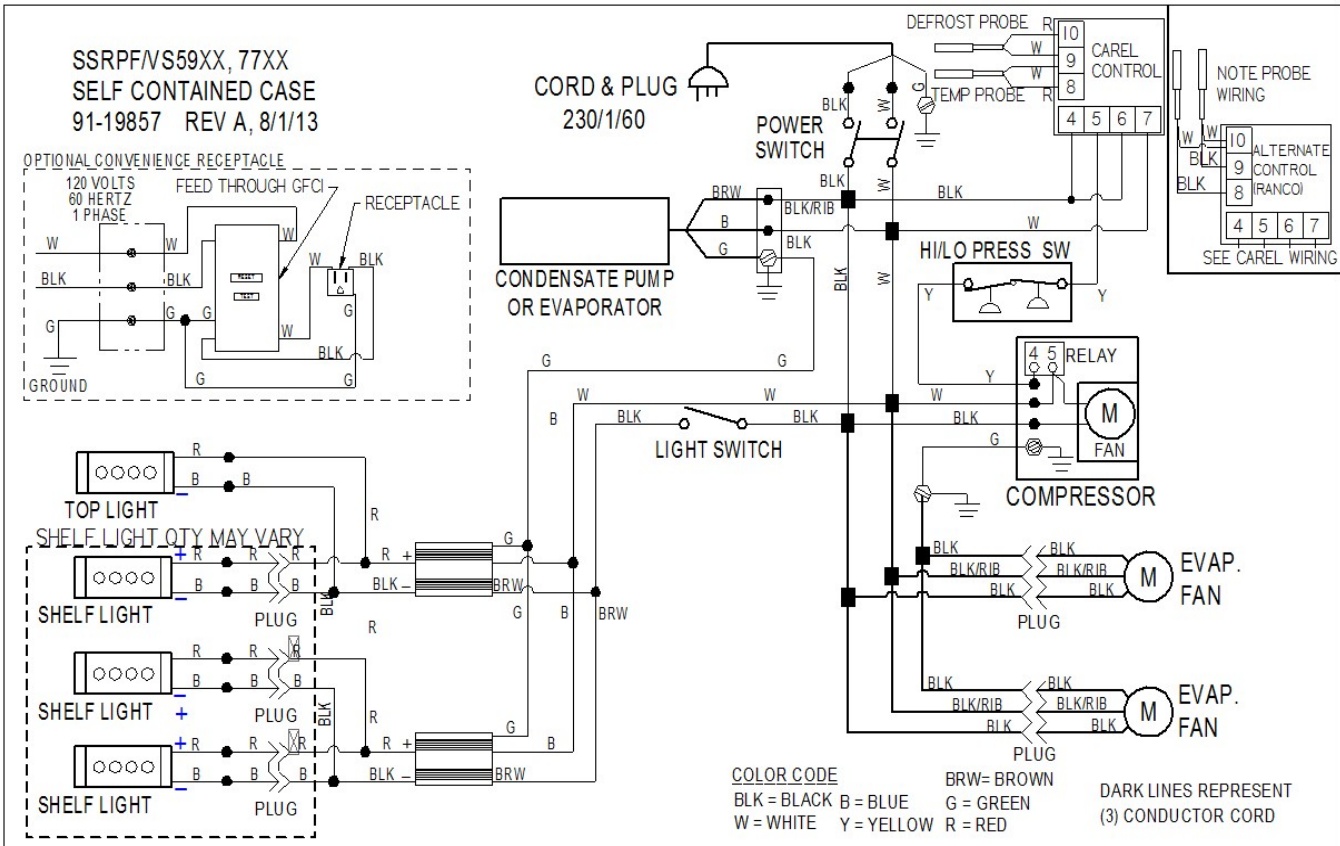

17.2 SELF CONTAINED (MFG'D AFTER 1/1/19)

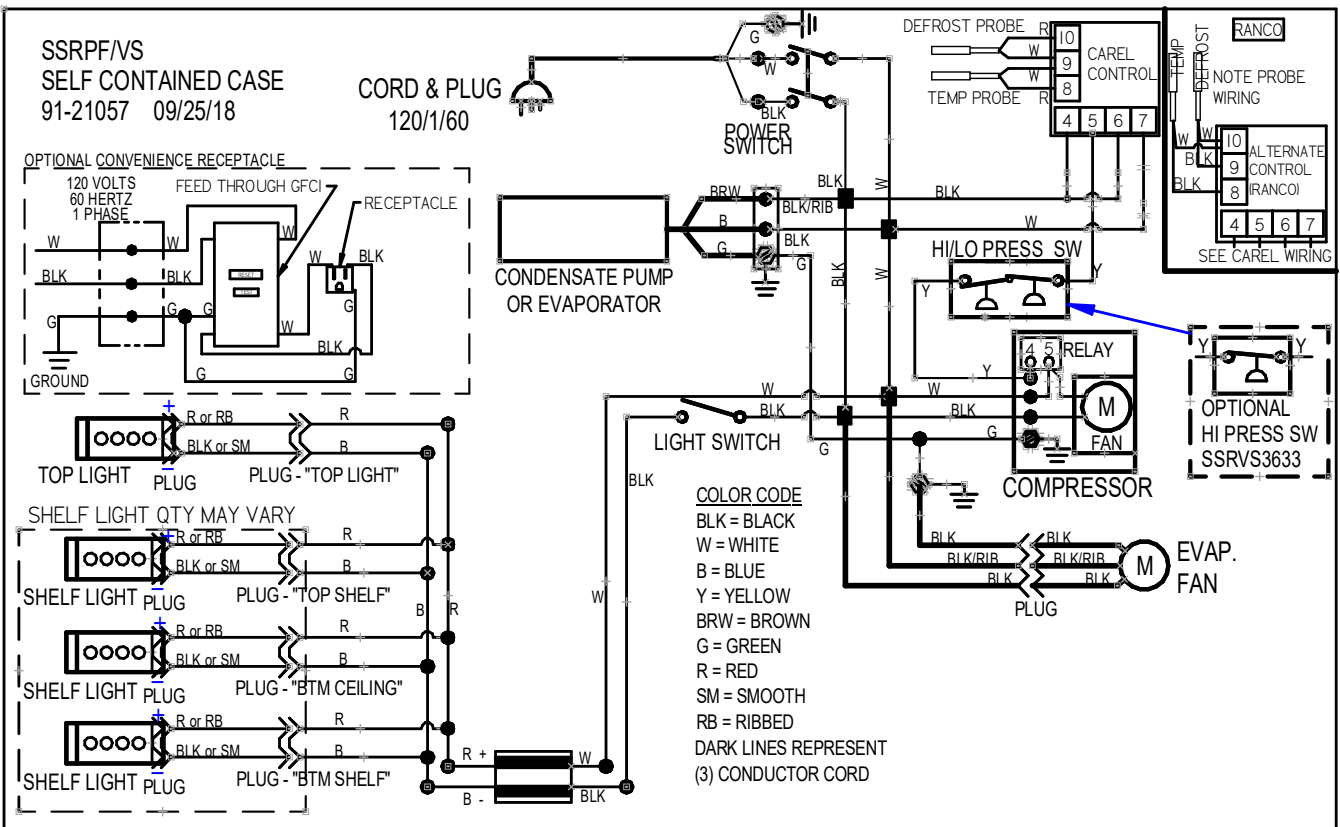

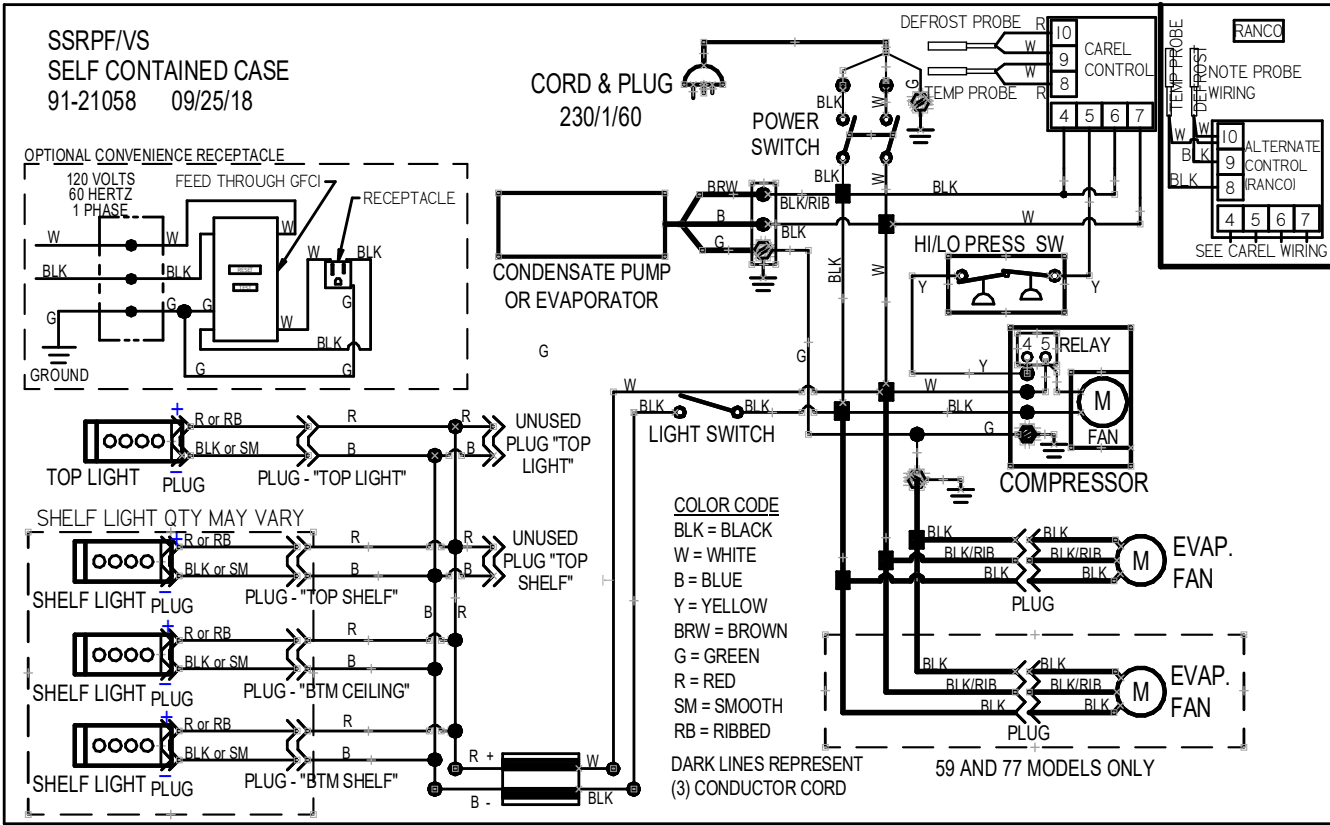

17.3 SELF CONTAINED (MFG'D AFTER 12/1/19)

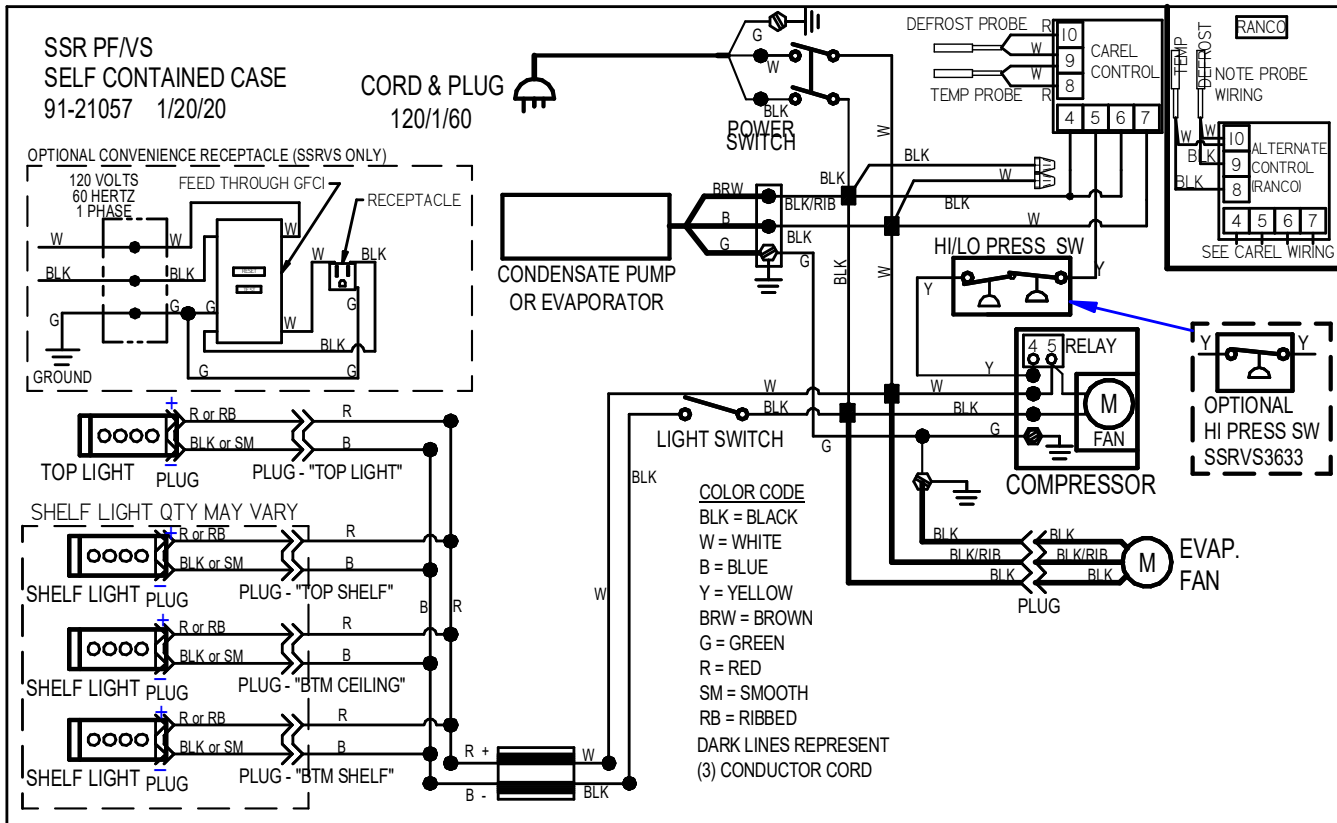

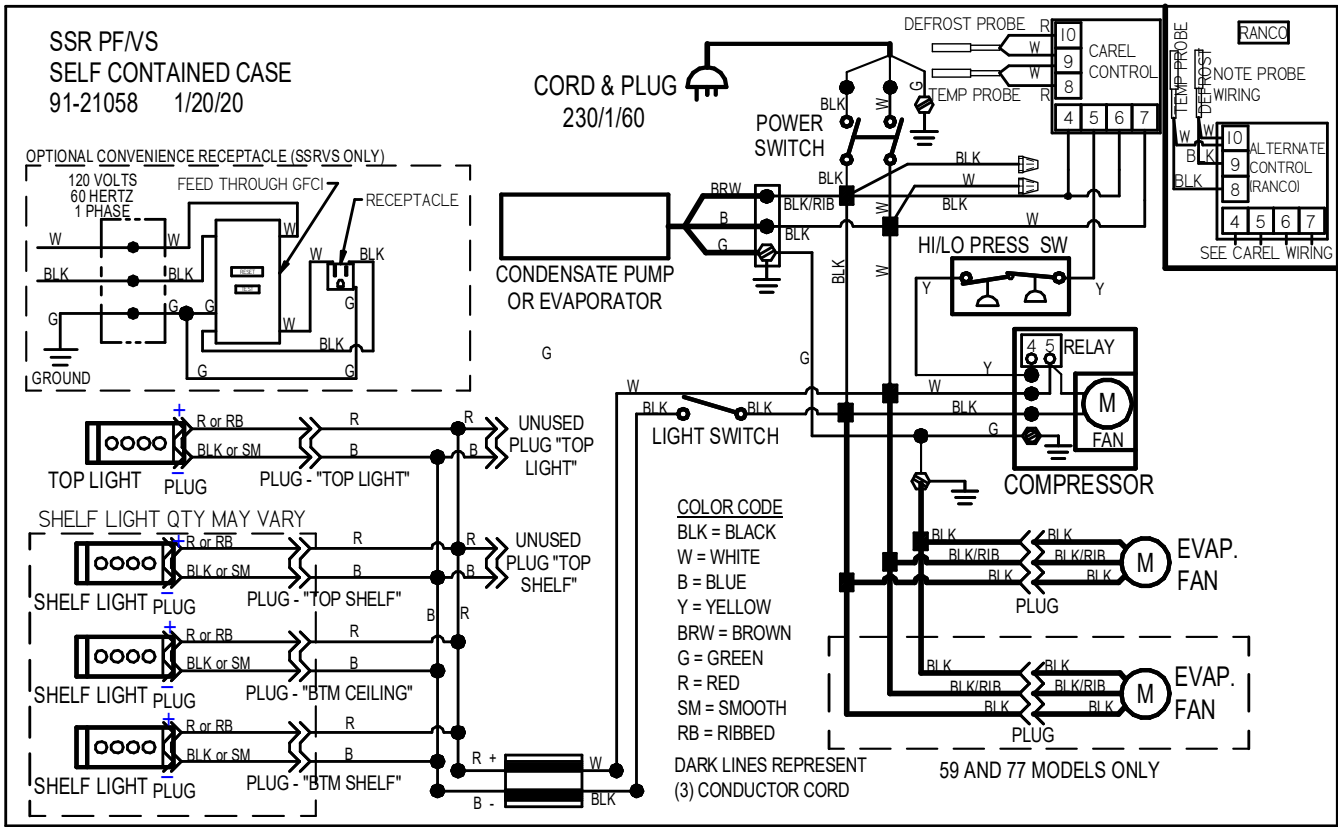

17.4 REMOTE (MFG'D BEFORE 1/1/19)

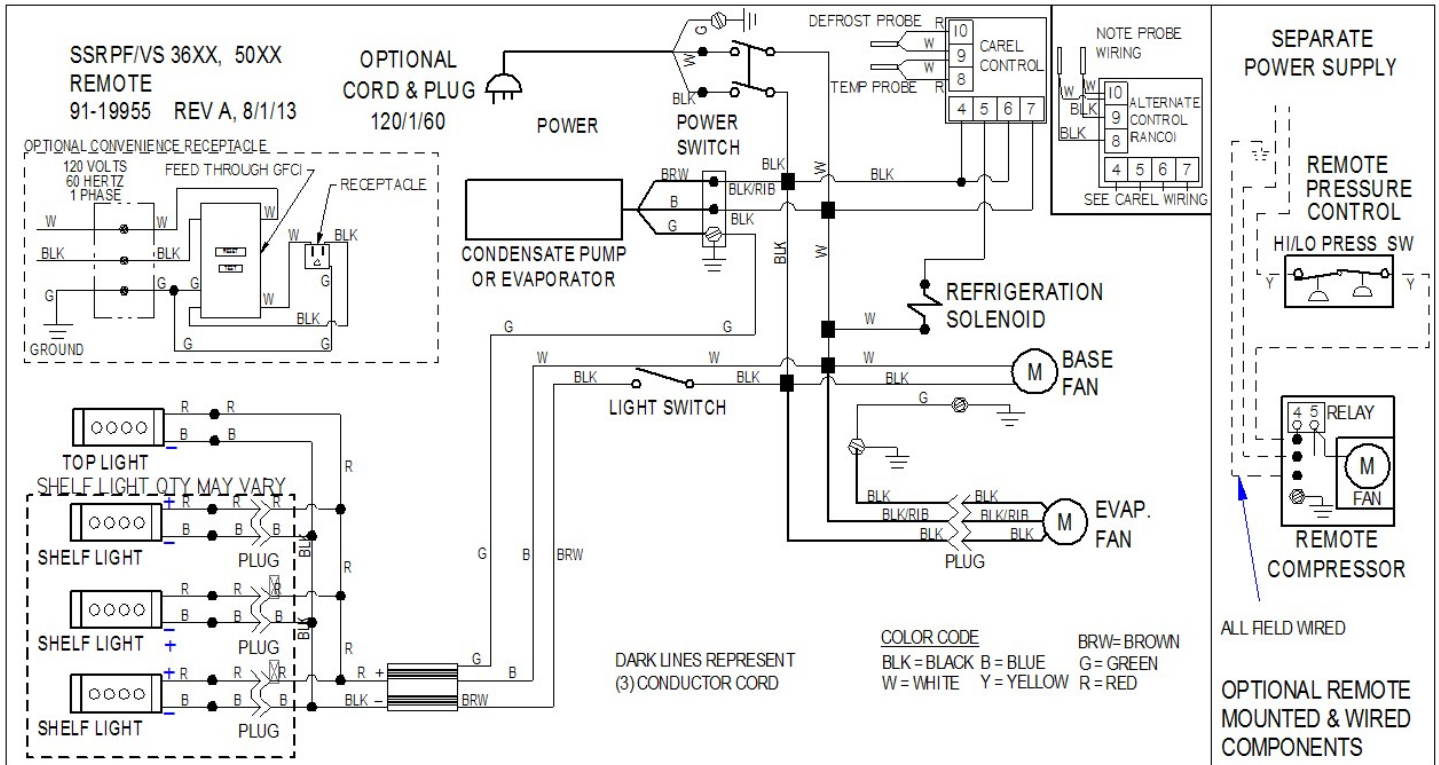

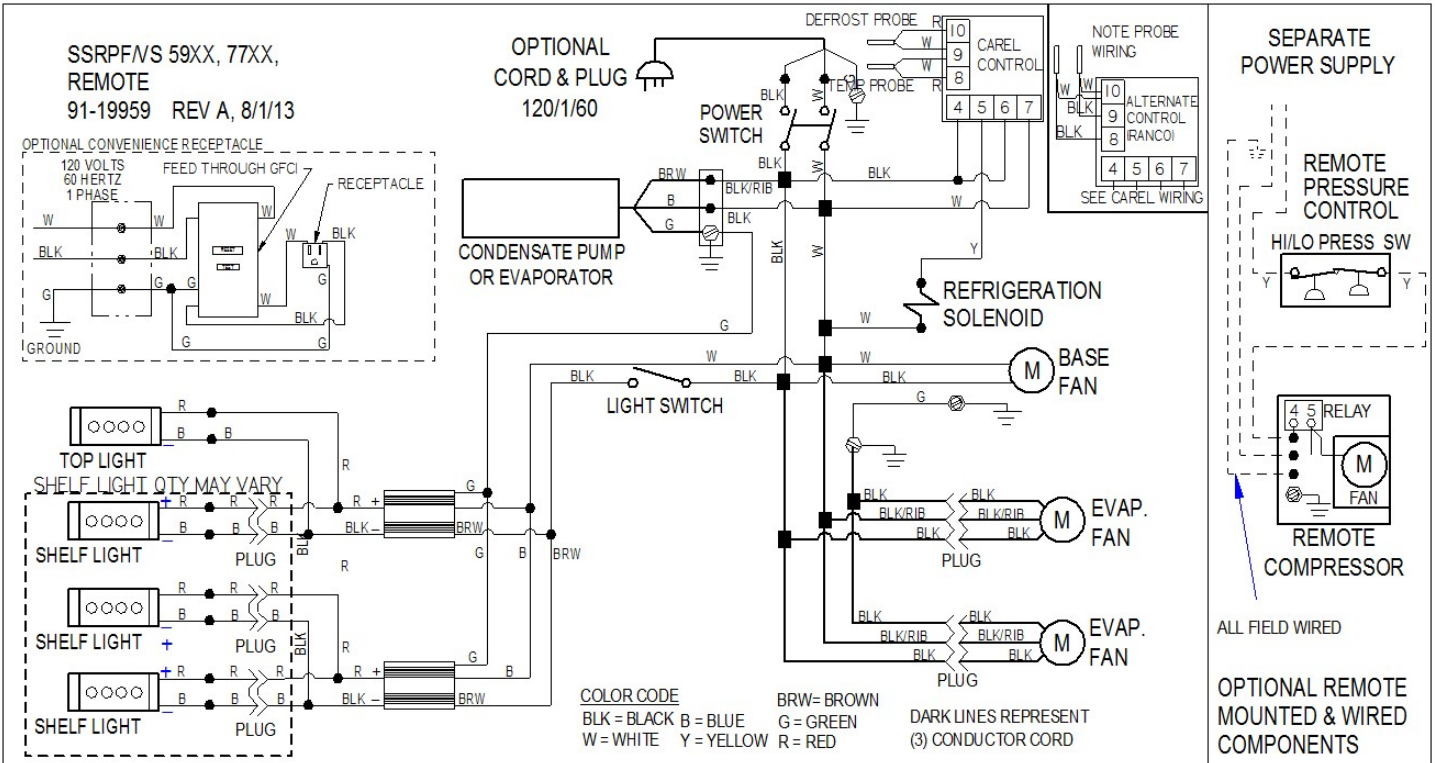

17.5 REMOTE (MFG'D AFTER 1/1/19)

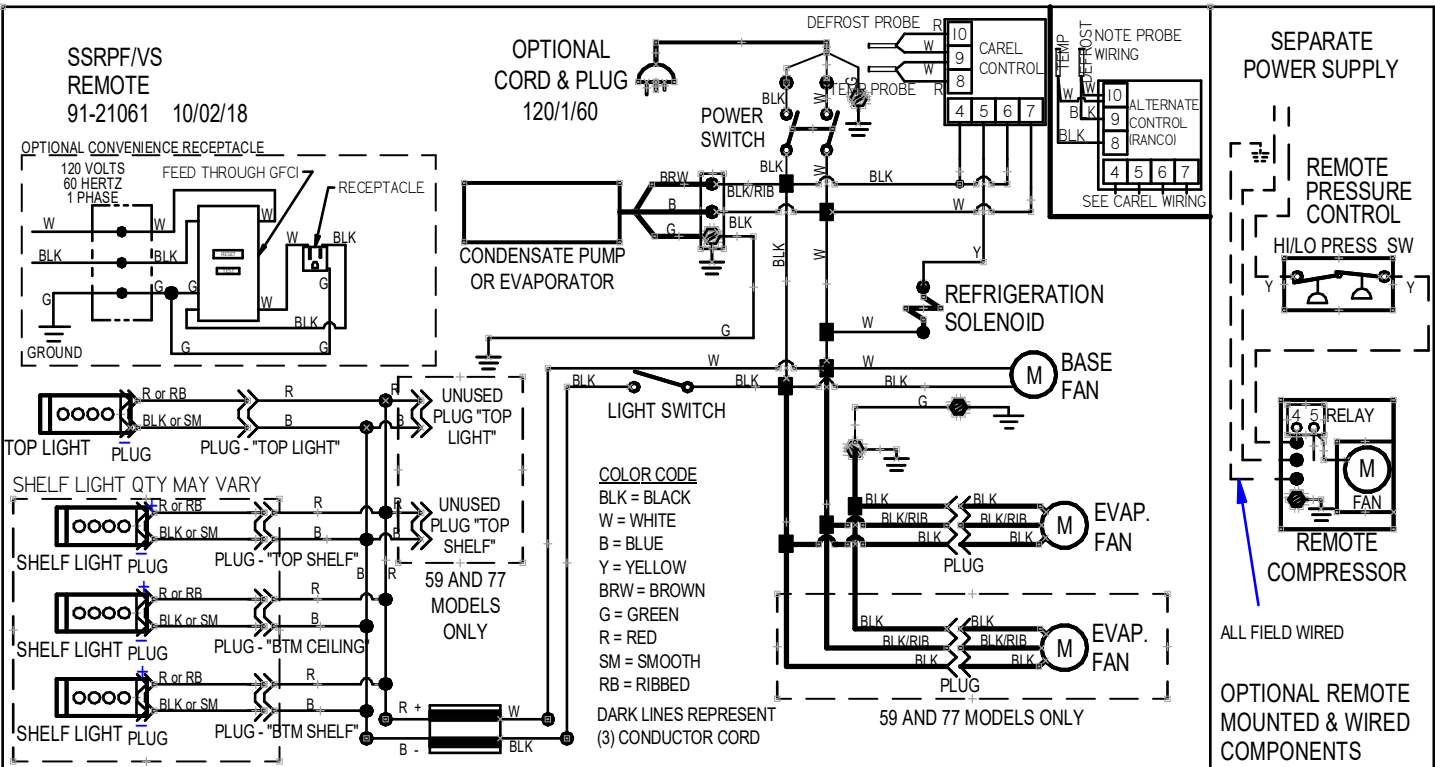

(18) REPLACEMENT PARTS

E3555-1.EXCEL

REFRIGERATION	SSRPF3652/ SSRVS3642/	SSRPF5052/ SSRVS5042/	SSRPF5952/ SSRVS5942/	SSRPF7752/ SSRVS7742/
Compressor (Self Contained)	30-20622	30-20623	30-18645	30-18645
Condensing Unit (Self Contained)	30-20511	30-20512	30-18215	30-18215
Evaporator Coil	33-13356	33-13357	33-13358	33-13358
TXV	32-19420	32-19419	32-19419	32-19416
EEV (AFTER 12/1/19)	32-21228			
Filter Drier	32-12626	32-12626	32-12626	32-12626
Sight Glass	32-54010	32-54010	32-54010	32-54010
Evaporator Fan Motor (52,42 Self Contained)	41-17981	41-19070	41-19070	41-19070
Evaporator Fan Motor (Remote)	41-17981	41-17981	41-17981	41-17981
Evaporator Fan Blade	72-17355	72-17355	72-17355	72-19270
Latch Evaporator Housing to Coil	66-13640	66-13640	66-13640	66-13640
Dual Pressure Control (52,42 Self Contained)	32-51009	32-51009	32-51009	32-51009
Temperature Control (52,42)	32-19864-6	32-19864-6	32-19864-6	32-19864-6
Temperature Probe	32-19866 (2)	32-19866 (2)	32-19866 (2)	32-19866 (2)
Temperature Probe, EEV (AFTER 12/1/19)	32-21224			
Pressure Transducer, EEV (AFTER 12/1/19)	32-21225			
Solenoid Remote Refrigeration (Remote)	32-30141	32-30141	32-30141	32-30141
Condensate Pan (52,42 Self Contained)	SA5302-1	SA5302-2	SA5302-2	SA5302-2
Condensate Pan Heater (Self Contained)	40-19331	40-19392	40-19392	40-19392
Condensate Pump (Remote)	47-15686 120V	47-15681 230V	47-15681 230V	47-15681 230V
Thermometer	32-13662	32-13662	32-13662	32-13662
EEV Control (After 12/1/19)	32-21223			

REFRIGERATION	SSRVS3633	SSRVS3633	SSRVS3633	SSRVS3633
Compressor (Self Contained)	30-20622	30-20622	30-21092	30-21092
Condensing Unit (Self Contained)	30-20511	30-20511	30-20412	30-20412
Evaporator Coil	33-13356	33-13356	33-13358	33-13358
TXV	32-19420	32-19420	32-19419	32-19416
Filter Drier	32-12626	32-12626	32-12626	32-12626
Sight Glass	32-54010	32-54010	32-54010	32-54010
Evaporator Fan Motor (33 Self Contained)	41-17981	41-17981	41-19070	41-19070
Evaporator Fan Motor (Remote)	41-17981	41-17981	41-17981	41-17981
Evaporator Fan Blade	72-17355	72-19270	72-17355	72-19270
Latch Evaporator Housing to Coil	66-13640	66-13640	66-13640	66-13640
High Pressure Control (33 Self Contained)	32-11670	32-11670	32-51009	32-51009
Temperature Control (33)	32-19864-61	32-19864-61	32-19864-61	32-19864-61
Temperature Probe	32-19866 (2)	32-19866 (2)	32-19866 (2)	32-19866 (2)
Solenoid Remote Refrigeration (Remote)	32-30141	32-30141	32-30141	32-30141
Condensate Pan (33 Self Contained)	SA5302-4	SA5302-4	SA5302-5	SA5302-5
Condensate Pan Heater (Self Contained)	40-19331	40-19331	40-19392	40-19392
Condensate Pump (Remote)	47-15686 120V	47-15686 120V	47-15681 230V	47-15681 230V
Thermometer	32-13662	32-13662	32-13662	32-13662
EEV Control (After 12/1/19)	32-21223			

LIGHTING	SSRPF3652/ SSRVS3642/ SSRVS3633	SSRPF5052/ SSRVS5042/ SSRVS3633	SSRPF5952/ SSRVS5942/ SSRVS3633	SSRPF7752/ SSRVS7742/ SSRVS3633
Light Switch	41-11066	41-11066	41-11066	41-11066
Power Switch	41-18186	41-18186	41-18186	41-18186
Light Power Supply (Before 1/1/19)	39-19039	39-19039	39-19039	39-19039
LED Power Supply (After 1/1/19)	39-20986	39-20986	39-20986	39-20986
LED Ceiling Light Strip (Before 1/1/19)	42-19038-5	42-19038	42-19038-6	42-19038-3
LED Ceiling Light Strip (After 1/1/19)	42-20871-30C35	42-20871-42C35	42-20871-54C35	42-20871-72C35
LED Shelf Light Strip (Before 1/1/19)	42-19038-5	42-19038	42-19038-6	42-19038-3
LED Shelf Light Strip (After 1/1/19)	42-20871-30C35	42-20871-42C35	42-20871-54C35	42-20871-72C35
LED (12 Inch) Shelf Light Cord (Before 1/1/19)	43-16861-3	43-16861-3	43-16861-3	43-16861-3
LED (15 Inch) Shelf Light Cord (After 1/1/19)	43-20862-2B	43-20862-2B	43-20862-2B	43-20862-2B
LED (15 Inch) Shelf Light Cord (Before 1/1/19)	43-16861-1	43-16861-1	43-16861-1	43-16861-1
LED (18 Inch) Shelf Light Cord (After 1/1/19)	43-20862-3B	43-20862-3B	43-20862-3B	43-20862-3B
LED (18 Inch) Shelf Light Cord (Before 1/1/19)	43-16861-2	43-16861-2	43-16861-2	43-16861-2
LED (21 Inch) Shelf Light Cord (After 1/1/19)	43-20862-4B	43-20862-4B	43-20862-4B	43-20862-4B
Power Cord (Optional)	43-30818	43-17839	43-19090	43-19090

SSRPF END PANELS & GLASS	SSRPF3652	SSRPF5052	SSRPF5952	SSRPF7752
Glass End Clear	50-19775			
Glass End Reflective Left(Optional)	50-19775-1L			
Glass End Reflective Right(Optional)	50-19775-1R			
End Panel Assem. Left (Black)	68-19348-L			
End Panel Assem. Right (Black)	68-19348-R			
End Panel Assem. Left (Color needed)	68-19348-1L			
End Panel Assem. Right (Color needed)	68-19348-1R			
End Panel Assem. Left (Stainless)	SA5383-L			
End Panel Assem. Right (Stainless)	SA5383-R			
SSRVS42 END PANELS & GLASS	SSRVS3642	SSRVS5042	SSRVS5942	SSRVS7742
Glass End Clear	50-19799			
Glass End Reflective Left(Optional)	50-19799-1L			
Glass End Reflective Right(Optional)	50-19799-1R			
End Panel Assem. Left (Black)	68-19802-L			
End Panel Assem. Right (Black)	68-19802-R			
End Panel Assem. Left (Color needed)	68-19802-1L			
End Panel Assem. Right (Color needed)	68-19802-1R			
End Panel Assem. Left (Stainless)	SA5383-1L			
End Panel Assem. Right (Stainless)	SA5383-1R			
SSRVS33 END PANELS & GLASS	SSRVS3633	SSRVS5033	SSRVS5933	SSRVS7733
Glass End Clear	50-20061			
Glass End Reflective Left(Optional)	50-20061-1L			
Glass End Reflective Right(Optional)	50-20061-1R			
End Panel Assy. Left (Rounded Black)	68-20632-L			
End Panel Assy. Right (Rounded Black)	68-20632-R			
End Panel Assy. Left (Rounded Color needed)	68-20632-1L			
End Panel Assy. Right (Rounded Color needed)	68-20632-1R			
End Panel Assy. Left (Rounded Stainless)	SA5383-2L			
End Panel Assy. Right (Rounded Stainless)	SA5383-2R			

SHELVING	SSRPF3652 SSRVS3642	SSRPF5052 SSRVS5042	SSRPF5952 SSRVS5942	SSRPF7752 SSRVS7742
Glass Shelf 12 Inch (Optional)	52-19937-1	52-19937-2	52-19937-3	52-19937-4
Glass Shelf 15 Inch (Optional)	52-19938-1	52-19938-2	52-19938-3	52-19938-4
Glass Shelf 18 Inch (Optional)	52-19939-1	52-19939-2	52-19939-3	52-19939-4
Glass Shelf Retainer Clip (Optional)	SA4091			
Shelf Bracket 12 Inch	67-16038-6A			
Shelf Bracket 15 Inch	67-16038-7A			
Shelf Bracket 18 Inch	67-16038-8A			
Shelf Standard SSRPF 52	M19171			
Shelf Standard SSRVS 42	M19238			
Shelf Retainer, Front, Clear	W11438-14	W11438-15	W11438-16	W11438-17
Step Pans (Standard SSRVS33)	SA4486-1	SA4486-2	SA4486-3	SA4486-4

REAR DOORS SSRPF52 (Optional)	SSRPF3652	SSRPF5052	SSRPF5952	SSRPF7752
Track, Rear Door Bottom (Optional)	57-18628-1	57-18628-2	57-18628-3	57-18628-4
Track, Rear Door Jamb (Optional)	57-18626-3	57-18626-3	57-18626-3	57-18626-3
Track, Rear Door Top (Optional)	57-18627-1	57-18627-2	57-18627-3	57-18627-4
Door, Rear Outer Solid (Black)	53-19891-1	53-19891-2	53-19891-3	53-19891-4
Door, Rear Inner Solid (Black)	53-19890-1	53-19890-2	53-19890-3	53-19890-4
Inside Track, Door Bottom (Optional)	M16519-1	M16519-2	M16519-3	M16519-4
Inside Track, Door Top (Optional)	M19453-1	M19453-2	M19453-3	M19453-4
Inside Door, Left Slotted Blk. (Option.)	SA5409-1	SA5409-2	SA5409-3	SA5409-4
Inside Door, Right Slotted Blk. (Option.)	SA5410-1	SA5410-2	SA5410-3	SA5410-4
Door Catch, Outside (Optional)	M17196-1	M17196-1	M17196-1	M17196-1
Door Catch, Inside (Optional)	M17196-2	M17196-2	M17196-2	M17196-2

REAR DOORS SSRVS42 (Optional)	SSRVS3642	SSRVS5042	SSRVS5942	SSRVS7742
Track, Rear Door Bottom (Optional)	57-18628-1	57-18628-2	57-18628-3	57-18628-4
Track, Rear Door Jamb (Optional)	57-18626-4	57-18626-4	57-18626-4	57-18626-4
Track, Rear Door Top (Optional)	57-18627-1	57-18627-2	57-18627-3	57-18627-4
Door, Rear Outer Solid (Black)	53-19982-1	53-19982-2	53-19982-3	53-19982-4
Door, Rear Inner Solid (Black)	53-19981-1	53-19981-2	53-19981-3	53-19981-4
Inside Track, Door Bottom (Optional)	M16519-1	M16519-2	M16519-3	M16519-4
Inside Track, Door Top (Optional)	M19453-1	M19453-2	M19453-3	M19453-4
Inside Door, Left Slotted Blk. (Option.)	SA5432-1	SA5432-2	SA5432-3	SA5432-4
Inside Door, Right Slotted Blk. (Option.)	SA5433-1	SA5433-2	SA5433-3	SA5433-4
Door Catch, Outside (Optional)	M17196-1	M17196-1	M17196-1	M17196-1
Door Catch, Inside (Optional)	M17196-2	M17196-2	M17196-2	M17196-2

REAR DOORS SSRVS33 (Optional)	SSRVS3633	SSRVS5033	SSRVS5933	SSRVS7733
Track, Rear Door Bottom (Optional)	57-18628-1	57-18628-2	57-18628-3	-
Track, Rear Door Jamb (Optional)	57-18626-5	57-18626-5	57-18626-5	-
Track, Rear Door Top (Optional)	57-18627-1	57-18627-2	57-18627-3	-
Door, Rear Outer Solid (Black)	53-19982-5	53-19982-6	53-19982-7	-
Door, Rear Inner Solid (Black)	53-19981-5	53-19981-6	53-19981-7	-
Inside Track, Door Bottom (Optional)	M16519-1	M16519-2	M16519-3	-
Inside Track, Door Top (Optional)	M19453-1	M19453-2	M19453-3	-
Inside Door, Left Slotted Blk. (Option.)	SA5432-17	SA5432-18	SA5432-19	-
Inside Door, Right Slotted Blk. (Option.)	SA5433-17	SA5433-18	SA5433-19	-
Door Catch, Outside (Optional)	M17196-1	M17196-1	M17196-1	-
Door Catch, Inside (Optional)	M17196-2	M17196-2	M17196-2	-

MISCELLANEOUS	SSRPF3652 SSRVS3642	SSRPF5052 SSRVS5042	SSRPF5952 SSRVS5942	
Air Deflector Front Clear	15-19827-1	15-19827-2	15-19827-3	
Security Night Cover Panel SSRPF(Optional)	M19299-1	M19299-2	M19299-3	
Security Night Cover Panel SSRVS42(Optional)	M19367-1	M19367-2	M19367-3	M19367-4
Security Night Cover Panel SSRVS33(Optional)	M19367-5	M19367-6	M19367-7	M19367-8
Security Night Cover Latch (Optional)	66-11727	66-11727	66-11727	66-11727

California Residents Only.

⚠ WARNING

This product can expose you to chemicals including chromium which is known to the State of California to cause cancer and birth defects or other reproductive harm. For more information go to www.P65Warnings.ca.gov

