



Installation & Operating Manual

P/N 54110

OASIS REFRIGERATED "BOX CASES" / SELF-CONTAINED & REMOTE / OPTIONAL SECURITY COVERS / TOP-MOUNTED CONDENSER PACKAGES ON CERTAIN MODELS

Important!
If You Are Adjoining Cases, See Synchronous Defrost Connection Instructions on Page 8 AND Adjoinment Instructions on Page 9 Of This Operating Manual.



Model B32

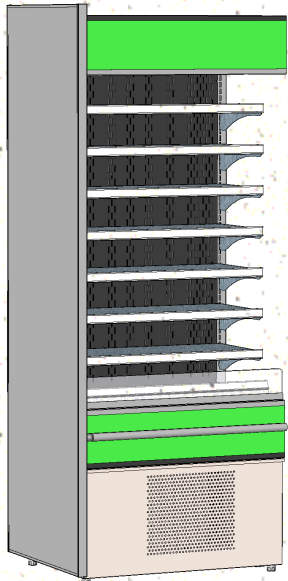

Model B32.7413
(End Panel Removed As Part Of Lineup)

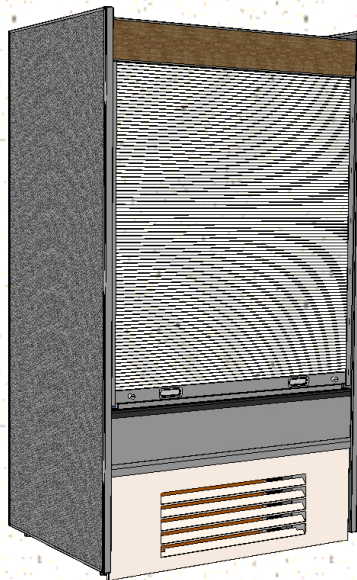

Model B4732
(With Optional Roll-Down Security Cover)

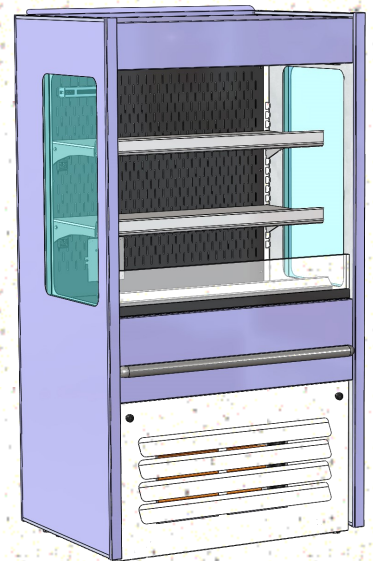

Model B22.6817

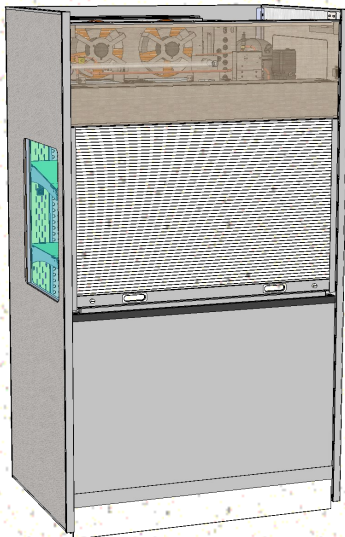

Model B5932TM.6785 (Similar To B4732TM.6785) / (Top-Mounted Condenser Pkg. / Underside Pump) / Optional Rear Doors

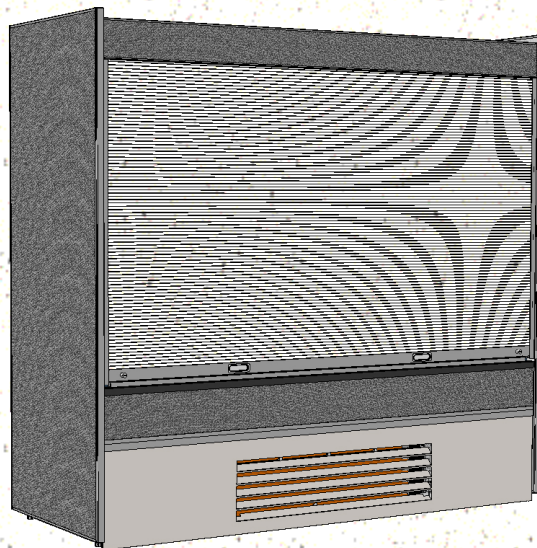

Model B8832 (With Optional Roll-Down Security Cover)

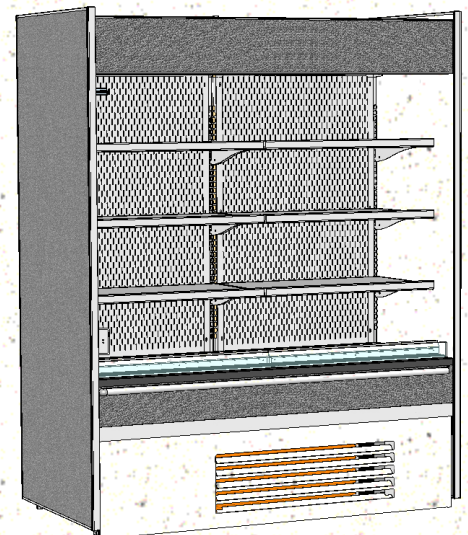

Model B6632SC.6241



888 E. Porter Road · Muskegon, MI 49441 Phone: 231.798.8888 Fax: 231.798.4960 www.structuralconcepts.com

TABLE OF CONTENTS / MODELS TO WHICH THIS MANUAL IS APPLICABLE

OVERVIEW / TYPE / COMPLIANCE / WARNINGS / PRECAUTIONS / WIRING / PLUGS	3-4
INSTALLATION: CASE REMOVAL (VIA LEVELERS & CASTERS)	5
INSTALLATION, CONTINUED: POSITIONING & ALIGNING CASE / ADJUSTING LEVELERS	6
INSTALLATION, CONTINUED: OPTIONAL SECURITY COVER INSTRUCTIONS	7
INSTALLATION, CONTINUED: SYNCHRONOUS DEFROST CONNECTION (OPTIONAL)	8
INSTALLATION, CONTINUED: ADJOINMENT INSTRUCTIONS	9
FRONT GRILLE REMOVAL / CONDENSER PACKAGE / OVERFLOW PAN / MAIN POWER SWITCH / CAREL® THERMOSTAT	10
EVAPORATOR COIL FAN DISCHARGE / TXV (THERMOSTATIC EXPANSION VALVE)	11
HONEYCOMB AIR DIFFUSER ACCESS	12
LED LIGHT FIXTURES	13
OPTIONAL ROLL-DOWN SECURITY COVER - MODEL B4732 ILLUSTRATED (YOUR MODEL MAY VARY) ..	14
OPTIONAL DUAL REAR DOORS (WITH PERFORATED PLENUM DOORS) / B5932TM SHOWN	15
OPTIONAL SINGLE REAR DOOR (WITH PERFORATED PLENUM AS PART OF DOORS) / B3632TM SHOWN	16
WALL SPACING / REAR GRILLE & VENTING PANEL (MAY NOT BE APPLICABLE TO YOUR MODEL)	17
CONDENSATE PAN ACCESS: STANDARD UNITS	18
CONDENSATE PAN ACCESS: REMOTE UNITS WITH CONDENSATE PANS ONLY	19
SELF-CONTAINED HOT GAS LOOP CONDENSATE PACKAGE LAYOUTS	20-21
SELF-CONTAINED HOT GAS LOOP CONDENSATE PACKAGE LAYOUTS - TOP MOUNTED	22
UNDERSIDE PUMP/DRAIN UNIT (FOR UNITS WITH TOP-MOUNTED SELF-CONTAINED COND. PKGS.) ...	23
LOAD LEVEL GUIDE / TEMPERATURE GUIDE (MODEL B42 SHOWN / APPLICABLE TO ALL OTHER MODELS IN MANUAL)	24
CLEANING SCHEDULE (TO BE PERFORMED BY STORE PERSONNEL)	25
PREVENTIVE MAINTENANCE - TO BE PERFORMED BY TRAINED SERVICE PROVIDERS ONLY	26-30
TROUBLESHOOTING (TO BE PERFORMED BY TRAINED SERVICE PROVIDER ONLY)	31-33
TROUBLESHOOTING (BY TRAINED SERVICE PROVIDERS ONLY) - CONDENSING SYSTEM	34
TROUBLESHOOTING (BY TRAINED SERVICE PROVIDERS ONLY) - EVAPORATOR SYSTEM	35
SERIAL LABEL LOCATION & INFORMATION LISTED / TECH INFO & SERVICE	36
CAREL® CONTROLLER OPERATING INSTRUCTIONS	37-39
DIXELL® XM67(X)K CONTROLLER OPERATING INSTRUCTIONS	40-43
TECHNICAL SERVICE CONTACT INFORMATION & WARRANTY INFORMATION	44

Partial List of Models To Which This Manual Is Applicable

B22.6817	B42.5955	B4732TM.6785	6032SC.6162	B7132SC.6162	CDR7317 (B42/B62 ADJOINMENT)
B32 CORE	B42.6662	B4732SC.7382	B6032SC.6241	CDR7317	
B32.5955A	B4732	B4736SC.7455	B62	B82	
B3632	B4732SC.6162	B5932	B6632SC.6241	B8832	
B3632TM	B4732SC.7773	B5932TM	B7132 B7132TM	B8832TM	
B42	B4732TM	B5932TM.6785	B7132TMDR	B9232	

OVERVIEW

- These Structural Concepts merchandisers are designed to merchandise packaged products at 41 °F (5 °C) or less product temperatures.
- Product must be pre-chilled to 41 °F (5 °C) or less product temperatures prior to placing in merchandiser.
- Cases should be installed and operated according to this operating manual's instructions to ensure proper performance.
- Improper use will void warranty.

TYPE I vs. TYPE II ENVIRONMENTAL CONDITIONS

This unit is designed for the display of products in ambient store conditions where temperature and humidity are maintained within a specific range.

- Type I display refrigerators are intended for use in an area where environmental conditions are controlled and maintained so that the ambient temperature does not exceed 75 °F (24 °C) and 55% maximum humidity.
- Type II display refrigerators are intended for use in an area where environmental conditions are controlled and maintained so that the ambient temperature does not exceed 80 °F (27 °C) and 55% maximum humidity.

- If unsure if your unit is Type I or II, see tag next to serial label. See **SERIAL LABEL LOCATION & INFORMATION LISTED / TECH INFO & SERVICE** section in this manual for sample serial labels.

COMPLIANCE

- Performance issues when in violation of applicable NEC, federal, state and local electrical and plumbing codes are not covered by warranty. See below.

WARNINGS

- This sheet contains important warnings to prevent injury or death. Please read carefully!

REFRIGERANT DISCLOSURE STATEMENT

- This equipment is prohibited from use in California with any refrigerants on the "List of Prohibited Substances" for that specific end-use, in accordance with California Code of Regulations, title 17, section 95374.
- This disclosure statement has been reviewed and approved by Structural Concepts and Structural Concepts attests, under penalty of perjury, that these statements are true and accurate.



COMPLIANCE
This equipment **MUST** be installed in compliance with all applicable NEC, federal, state and local electrical and plumbing codes.



WARNING
Risk of electric shock. Disconnect power before servicing unit.
CAUTION! More than one source of electrical supply is employed with units that have separate circuits.
Disconnect ALL ELECTRICAL SOURCES before servicing.



WARNING
Hazardous moving parts. Do not operate unit with covers removed.
Fan blades may be exposed when deck panel is removed.
Disconnect power before removing deck panel.



WARNING
Condensate Pan is Hot!
Disconnect and allow to cool before cleaning or removing from case.



WARNING: This product can expose you to chemicals, including Urethane (Ethyl Carbamate), which are known to the state of California to cause cancer and birth defects or other reproductive harm. For more information go to P65Warnings.ca.gov.

PRECAUTIONS

- This sheet contains important precautions to prevent damage to unit or merchandise. Please read carefully!
- See previous page for specifics on **OVERVIEW**, **TYPE**, **COMPLIANCE** and **WARNINGS**.

WIRING DIAGRAM

- Each case has its own wiring diagram folded and in its own packet.
- Location: Diagram may be near ballast box, field wiring box, raceway cover, or other related location.



CAUTION! LAMP REPLACEMENT GUIDELINES
 LED and fluorescent lamps reflect specific size, shape and design. Any replacements must meet factory specifications, resist breakage and reflect similar appearance as lamps from factory.

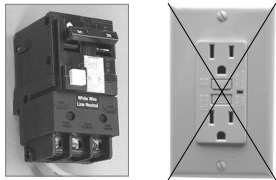

CAUTION! GFCI BREAKER USE REQUIREMENT
 If N.E.C. (National Electric Code) or local code requires GFCI (Ground Fault Circuit Interrupter), use a GFCI breaker in lieu of a GFCI receptacle.



CAUTION! POWER CORD AND PLUG MAINTENANCE
 Risk of electric shock. If cord or plug becomes damaged, replace only with cord and plug of same type.

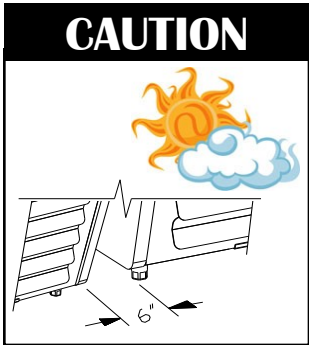

CAUTION! ADVERSE CONDITIONS / SPACING ISSUES

- Performance issues caused by adverse conditions are NOT warranted.
- Keep end panels tightly joined or at least 6" away from structures to prevent condensation. Keep rear panel at least 6" from wall/structure.
- Unit must be kept at least 15-feet from exterior doors, overhead HVAC vents or any air curtain disruption to maintain proper temperatures.
- Unit must not be exposed to direct sunlight or any heat source.
- Self-contained unit clearance: 6" min. air intake / 6" min. air discharge.

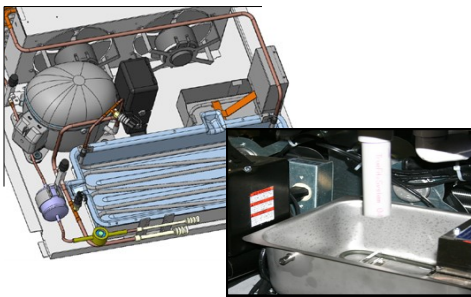

CAUTION! CHECK CONDENSATE PAN POSITION & PLUG
 Water on flooring can cause extensive damage!
 Before powering up unit, check and confirm that:

- Condensate pan is DIRECTLY UNDER condensate drain.
- Condensate pan plug is securely plugged into receptacle.
- Overflow pan has plug connected to its box. Units with optional Clean Sweep™ MUST HAVE two plugs connected.



CAUTION! DO NOT RELY ON THERMOMETERS OR THERMOSTATS FOR ACTUAL PRODUCT TEMPERATURES.

- Thermometers/thermostats reflect air temperatures ONLY.
- For ACTUAL food temperatures, use a calibrated food thermometer.

INSTALLATION: CASE REMOVAL (VIA LEVELERS & CASTERS)

1. Remove Case From Skid (Levelers)

- Remove shipping brace that may be securing case to skid.
- Support case to prevent tipping.
- *Caution! Levelers can be damaged if case hits floor with heavy force!*
- Carefully slide unit to rear of skid and tip backward off skid.
- Illustration may not reflect every feature or option of your particular case.
- Case can be repositioned with pallet truck when front lower panel is removed. Blocking may be necessary to obtain adequate height.

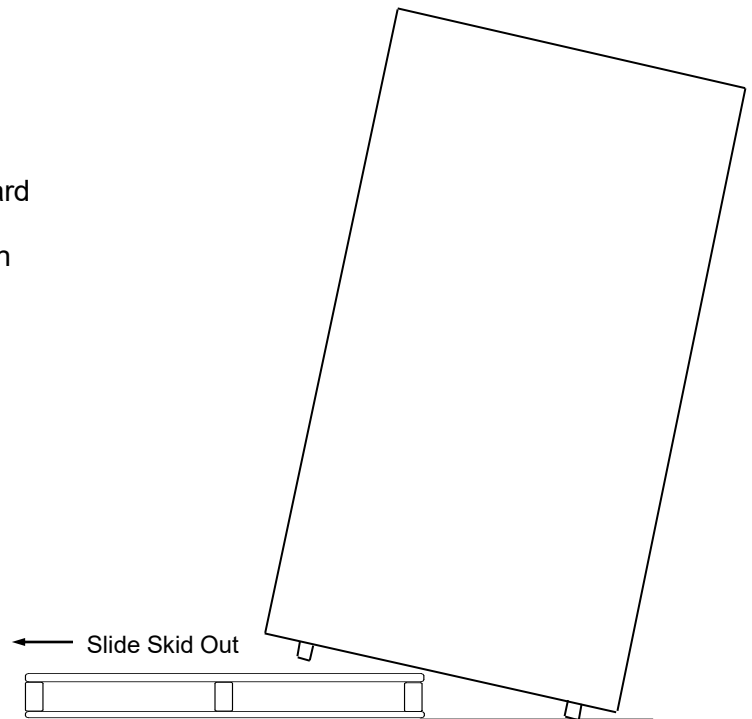

2. Remove Case From Skid (Casters)

Remove shipping brackets that secure casters to skid

- *Important! Case is shipped with levelers in the **DOWN** position (for stability). To prevent damage to the case, all levelers must be raised **ALL THE WAY UP** before moving unit off skid and into position.*
- After levelers are raised all the way up, place ramp up against skid (to allow case to smoothly roll off from skid).
- Maintain support of case at all times or center of gravity may cause case to fall.
- Roll unit to rear of skid. Roll down ramp and off skid.

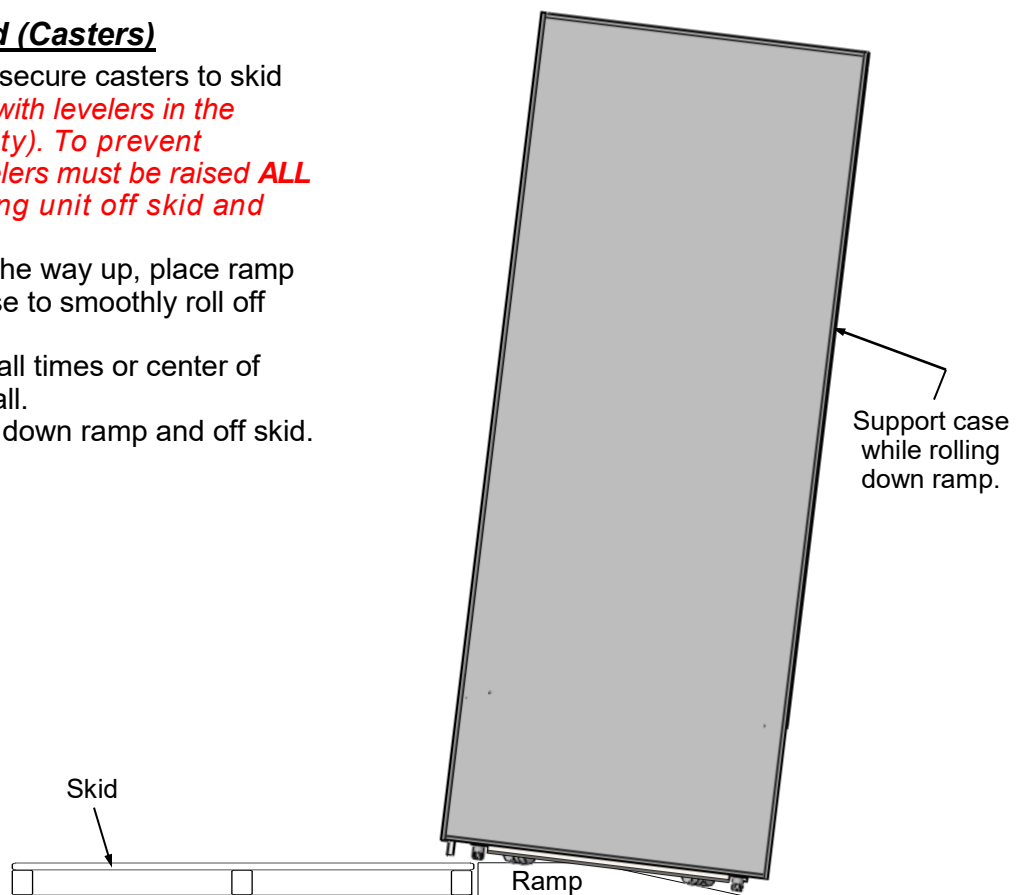

3. Position & Align Alongside Other Cases

- Before adjusting levelers, make certain that the case is in proper position and, if required, aligned with adjoining case(s).
- This may require the repositioning of the case you are installing or the already positioned cases.

4. Adjusting Levelers

- **Important! After case is in proper position, levelers must then be LOWERED to floor.**
- Adjust levelers so the case is level and plumb.
- You may need to remove front and/or rear toe-kick to access levelers.
- Use adjustable wrench to adjust leveler.
- Depending upon case weight it may be necessary to use a pry bar to accomplish this task.
- Do not use pry bar on toe-kick as it may buckle.
- Do not use pry bar on end panel as it may chip.
- Use pry bar **ONLY** on base frame to avoid damaging case.
- See illustrations below.

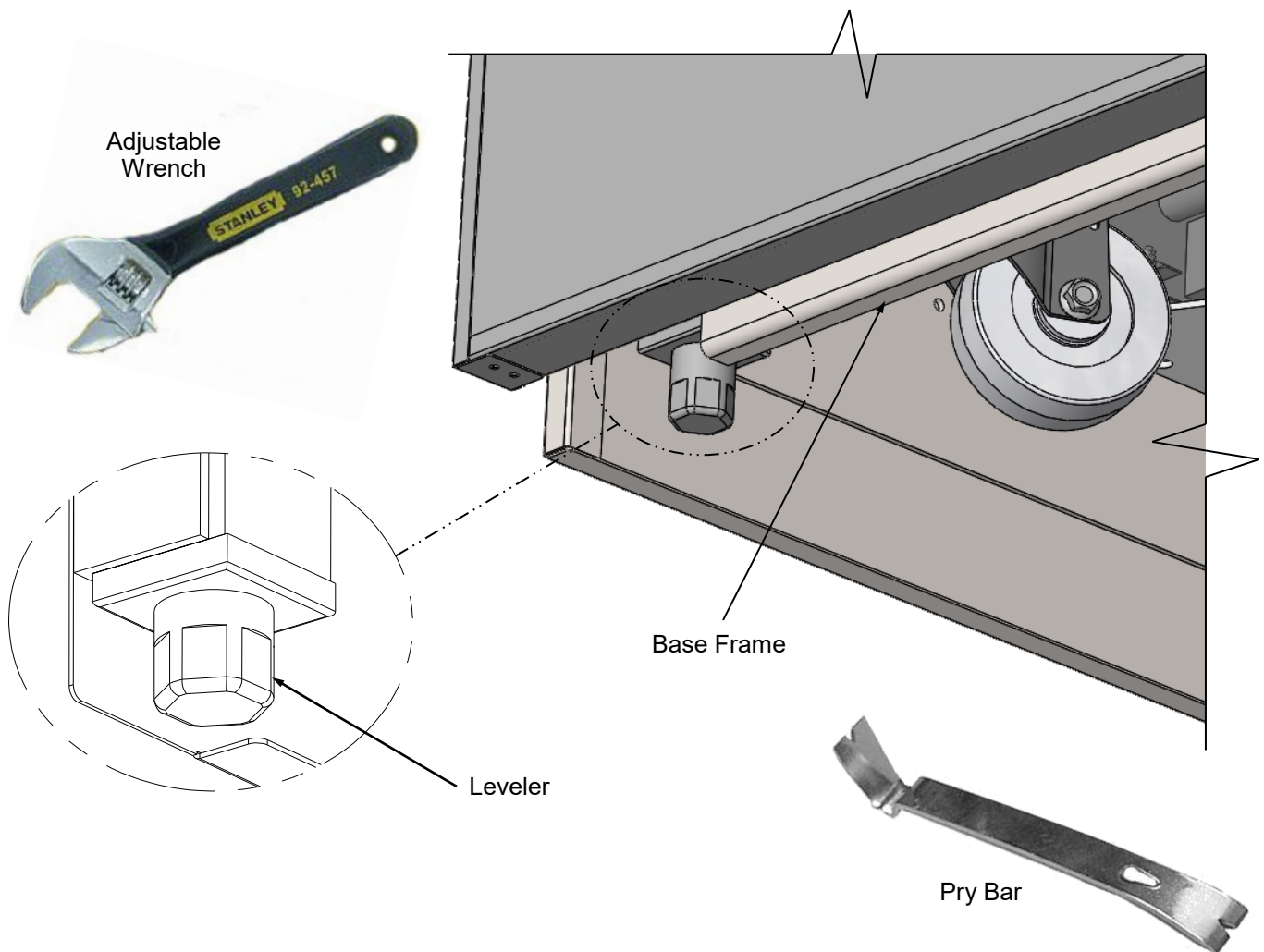

5. Optional Security Cover Instructions

Caution! Security Cover MUST Be Placed On OUTSIDE of Acrylic Air Deflector and INSIDE Lower Security Bracket To Fit Properly.

> Steps A, B and C correspond to this sheet's illustrations A, B and C. Follow these step-by-step instructions for proper security cover placement.

- A. Firmly hold security cover handles, and place the bottom of the security cover on the OUTSIDE of the acrylic air deflector and INSIDE of lower security bracket.
- B. Lean upper edge of security cover against upper bracket retainer (shown with hidden lines in illustration "B" on this sheet).

- C. Check that the lock properly rotates its locking mechanism into support angle slot (at upper area).
- > When removing security cover from case, store in safe location away from foot traffic.
- > Manufacturing note: if your case DOES NOT HAVE the hardware shown on this sheet for proper placement of security cover, contact Structural Concepts Corporation Technical Service. Toll-free number is listed on the last page of this document.

Note: Illustrations Shown May Not Exactly Reflect Every Feature or Option of Your Particular Case.

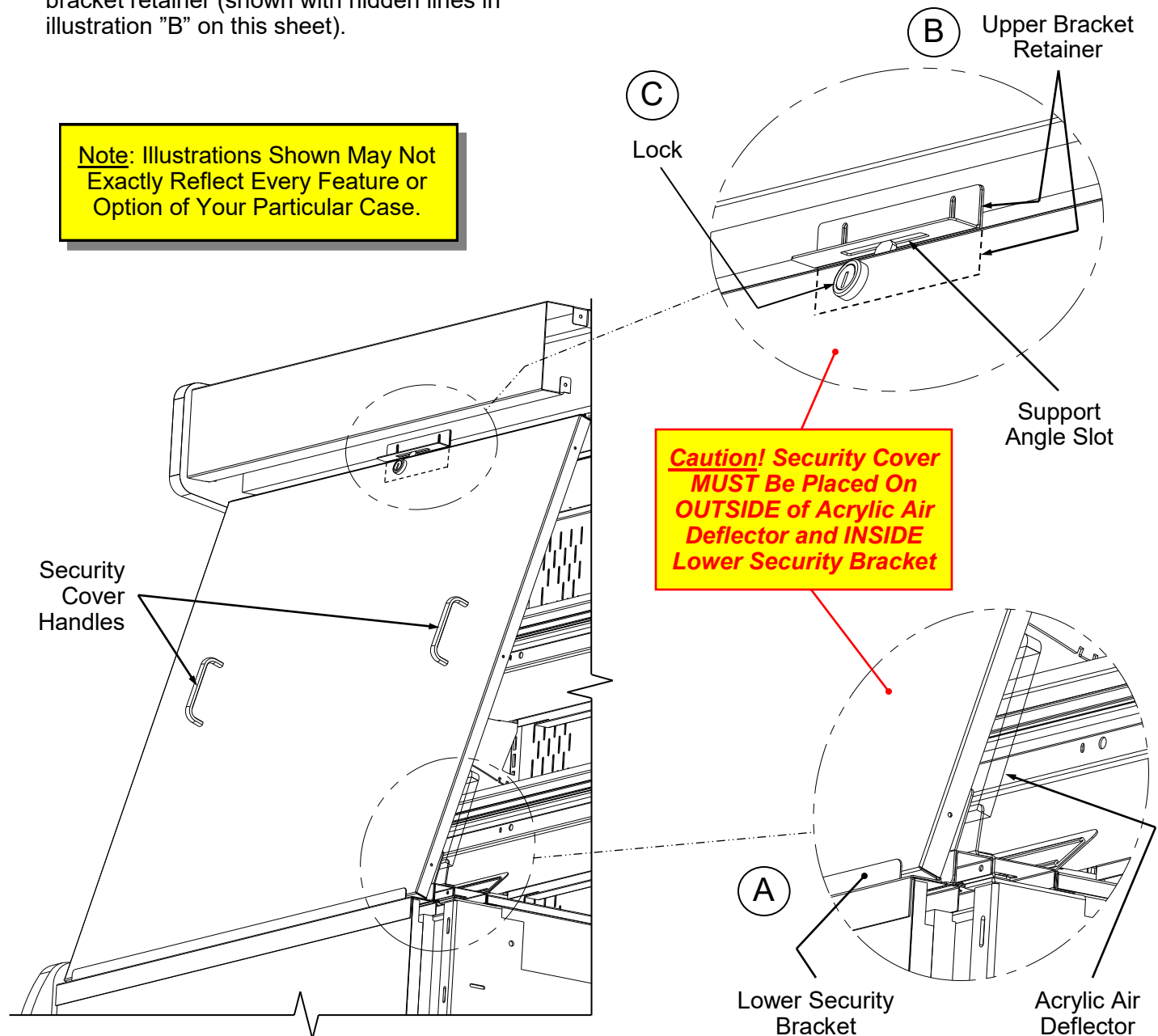

6. Synchronous Defrost Connection (Optional)

- Adjoined cases MUST HAVE its synchronous defrost plugs connected.
- See wiring diagram accompanying case.

Attention!

- Adjoined cases have synchronous defrosts.
- Synchronous Defrost Plugs Must Be Connected At Rear of Electrical Box During Case Adjoinment.
- See Your Case's Wiring Diagram For Instructions.

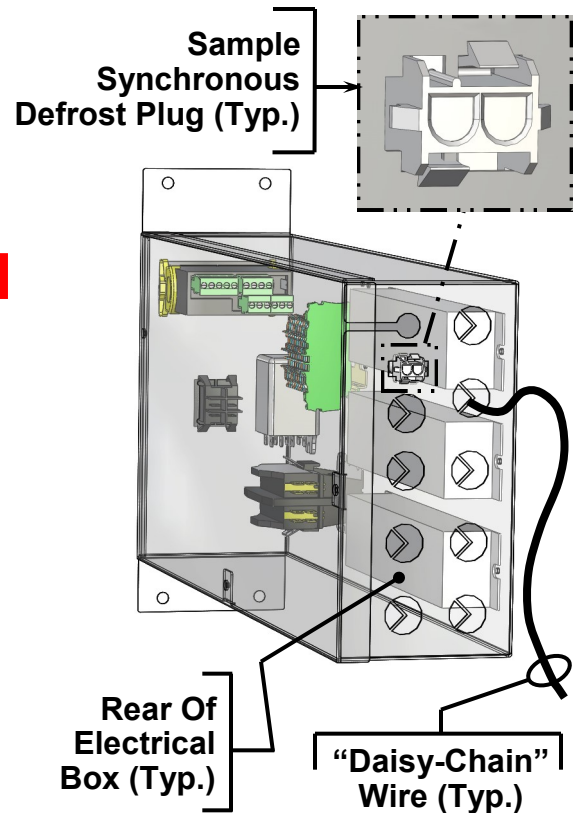

SCC Internal Note: Any Changes To This Sheet Must Also Be Made To SCC P/N 20-61248.

Note: "Daisy-Chain" Synchronous Wiring Must Route To Primary Case (At Left)

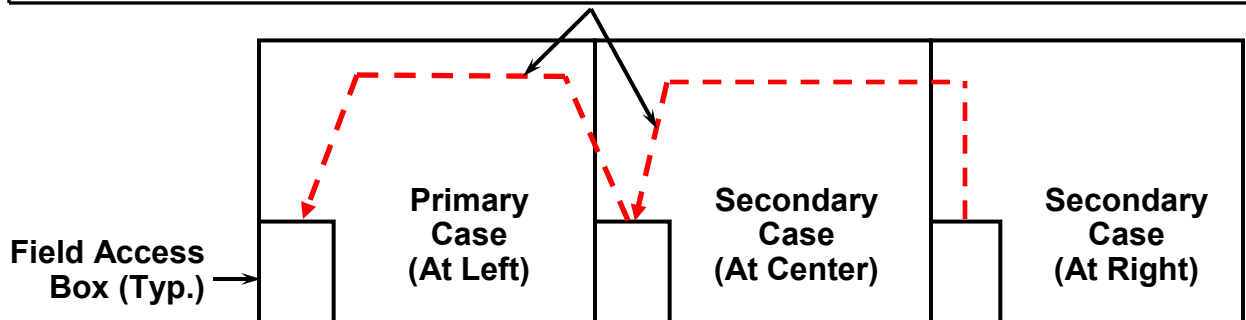

Sample Case Adjoinment / Case Front View

INSTALLATION, CONTINUED: ADJOINMENT INSTRUCTIONS

7. Overview / Silicone and Buty Application

Sealant Overview:

- Warranty is void if improper sealant is used.
- Sealing tub prevents air from escaping through seams between cases (causing condensation problems and reducing refrigeration efficiency).
- Sealing also prevents water from seeping between cases to the floor.

Silicone and Urethane Application:

- Form (1) INNER sanitation bead AND (1) refrigeration bead BEFORE case is adjoined (as shown).
- Then, AFTER case is adjoined (and bolted), form (1) OUTER sanitation bead (as shown) into any cavities or gaps that may remain along outer adjointment areas where urethane has ALREADY been applied.
- Also place a thick bead of urathane around drain.

8. Bolting Adjoined Units

- Bolt holes are at various locations (depending upon model). Model illustrated MAY NOT exactly reflect your particular unit but will likely be similar in layout.
- Use appropriately sized nuts and bolts for each hole.
- #1 hole is accessible at honeycomb (slight adjustment or removal of honeycomb air diffuser may be necessary for attachment of bolt).
- #2 hole is accessible near rear plenum.
- #3 holes are accessible after removing decking.
- #4-6 holes are accessible after removing front panel.
- #7-9 holes are accessible after removing rear panel.

- #3 holes are accessible after removing decking.
 - #4-6 holes are accessible after removing front panel.
 - #7-9 holes are accessible after removing rear panel.
- >> Be sure to reattach components to case after the adjointment process is complete.

Note: Any changes to this document must also be made do P/N 20-76683

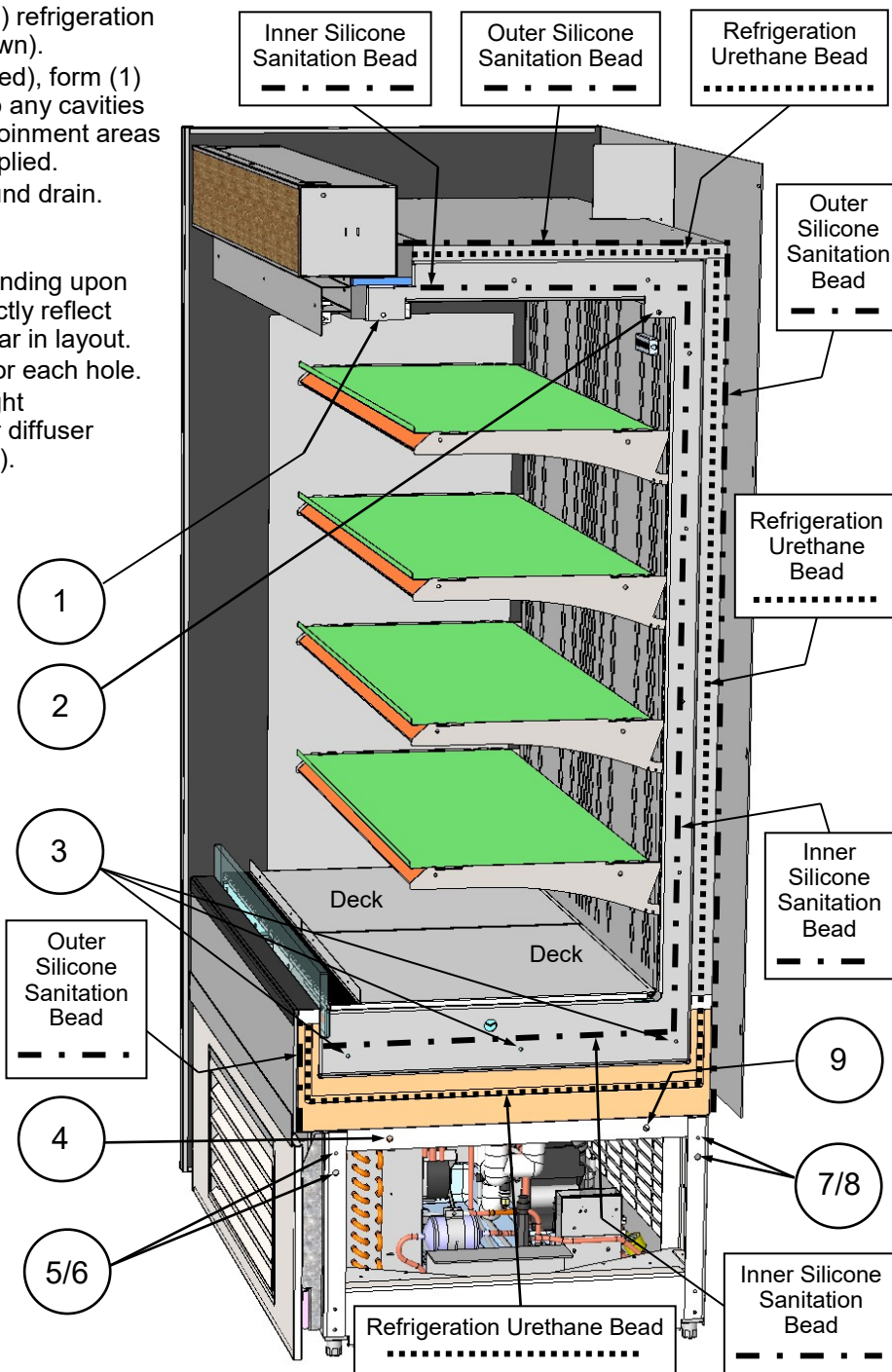

Note: Model B4732 (Unit Shown) May Not Exactly Reflect Every Feature or Option of Your Particular Case.

1. Removable Front Grille

- Front grille can be removed/replaced via thumbscrew and magnet removal method (shown top-right) OR slot and hook method (shown lower-right).
- Also, hook/magnet method (shown lower-left).

2. Check That Overflow Condensate Pan is Properly Connected To Outlet

- **Caution! Condensate pan can come unplugged from its electrical outlet during shipment!**
- If case runs without proper connection, water will overflow pan and drain onto floor causing damage!
- Before turning case on, check that power cord from condensate pan is properly plugged in.
- See TROUBLESHOOTING section in operating manual for additional information.

3. Turning On Power To Case

- Plug in power cord.
- Main power switch may be turned on by reaching through front grille; however, removal of front grille will allow unhindered access.
- Main power switch is located on main ballast box, below controller. See illustration at right.

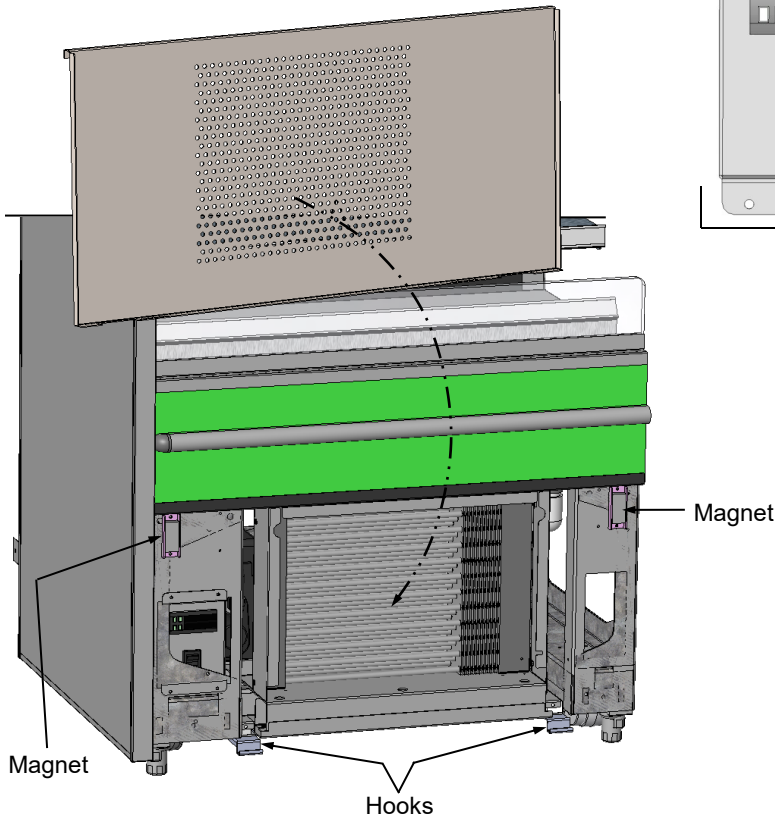
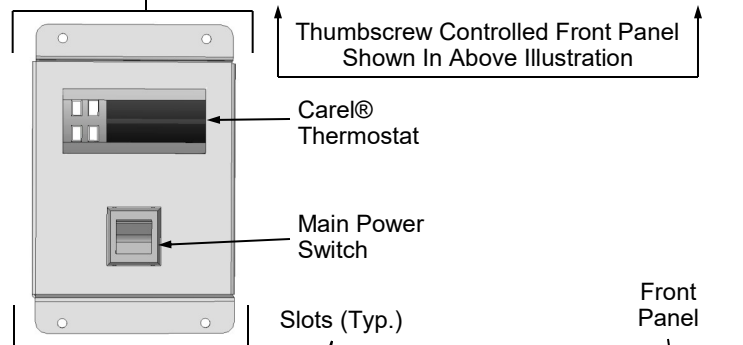
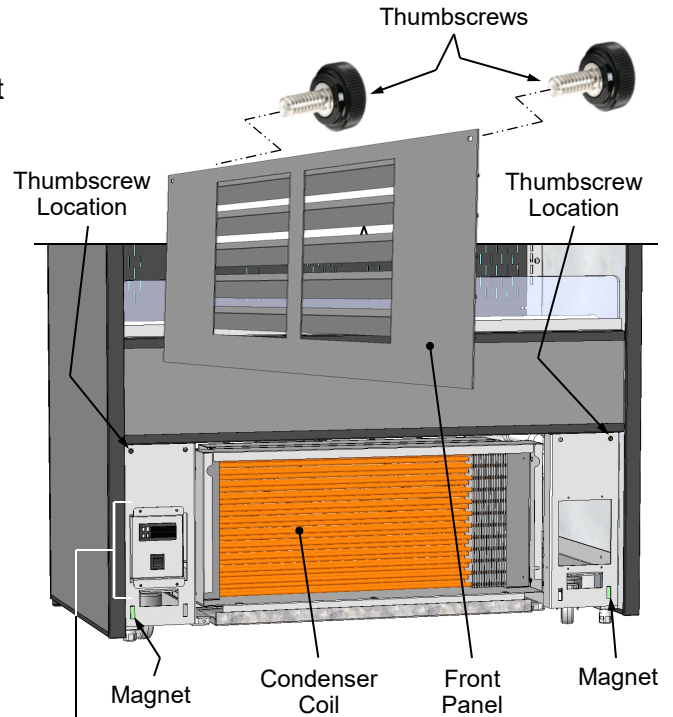

Front Panel Style That Rests on Hooks And Attaches To Magnets (Model B32.7413 Shown)

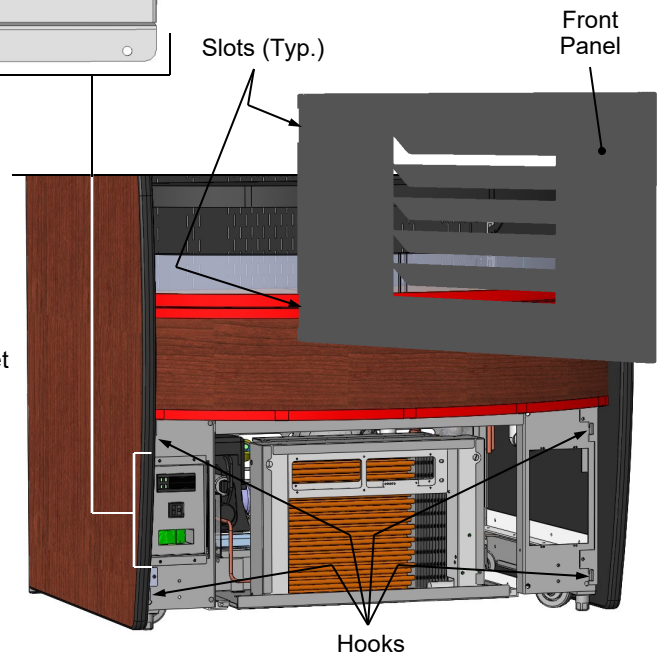

Front Panel With Slots and Hooks Shown In Above Illustration

EVAPORATOR COIL FAN DISCHARGE / TXV (THERMOSTATIC EXPANSION VALVE)

1. Evaporator Coil Fan Discharge

- When Main Power Switch is turned on, refrigeration assembly will energize (see **CASE START-UP & REFRIGERATION ASSEMBLY ACCESS** section).
- Evaporator coil fans should turn on. From inside of the case, check for discharge air from front baffle to confirm that the fans are functioning properly.
- When the case is in a start up mode or has been idle for a long period of time, the unit will require 75 minutes of run time to pull-down temperature.
- See below illustration.

2. TXV (Thermostatic Expansion Valve)

- TXV is under TXV access panel.
- Decking must be removed for access.
- TXV cover must also be removed for access (remove two thumb screws).
- See illustration below.
- Note: Standard cases have TXV at customer-left. For cases with EnergyWise, TXV is at customer-right.

Case Shown with End Panel, Decking, and TXV Cover Removed. Note: Illustration Above Has TXV at Customer Right. Your Case (If Standard / Non-EnergyWise Refrigeration Package) Will Have TXV Accessible at Customer-Left.

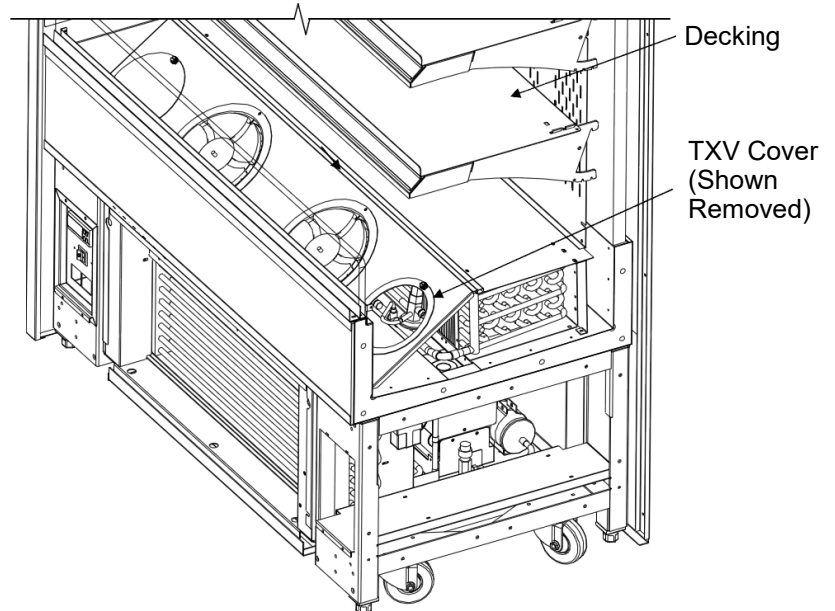

3. Sliding Condenser Package Out From Underside Of Case

- At shipment, removal of compressor pan shipment screws may be necessary to access condenser package. See illustration below-left.
- Refrigeration assembly base rests on plastic glides.
- Slide condenser package out from under case.

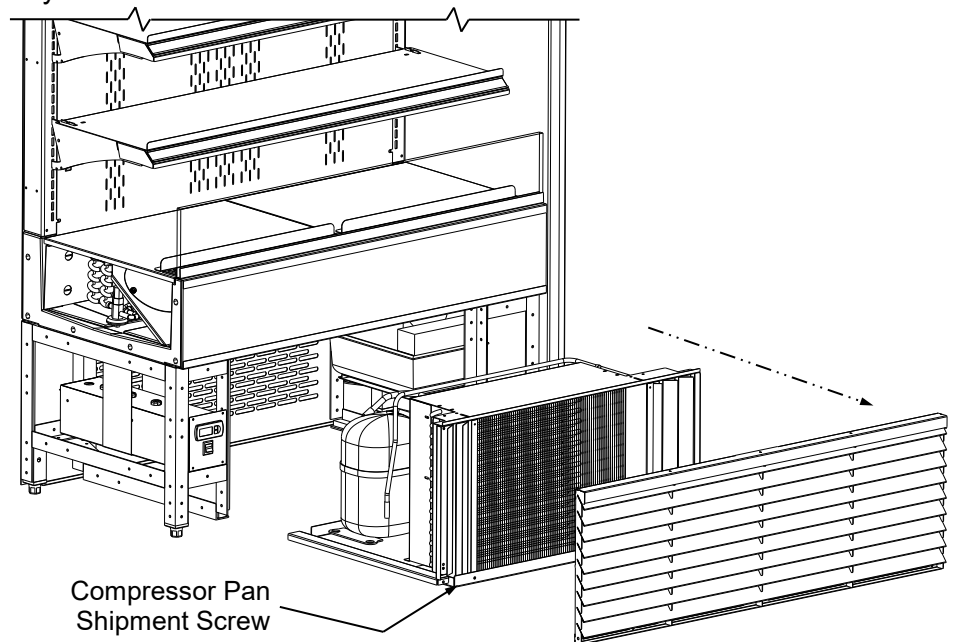

Above View Shows Condenser Package Slid Out From Under Case. Note: Illustration Shown May Not Reflect Every Feature Or Option of Your Particular Case.

HONEYCOMB AIR DIFFUSER

Honeycomb Air Diffuser

- Honeycomb is located in discharge air duct.
- See illustration below.
- Note: Illustration shown below is partially disassembled for illustrative purposes only.

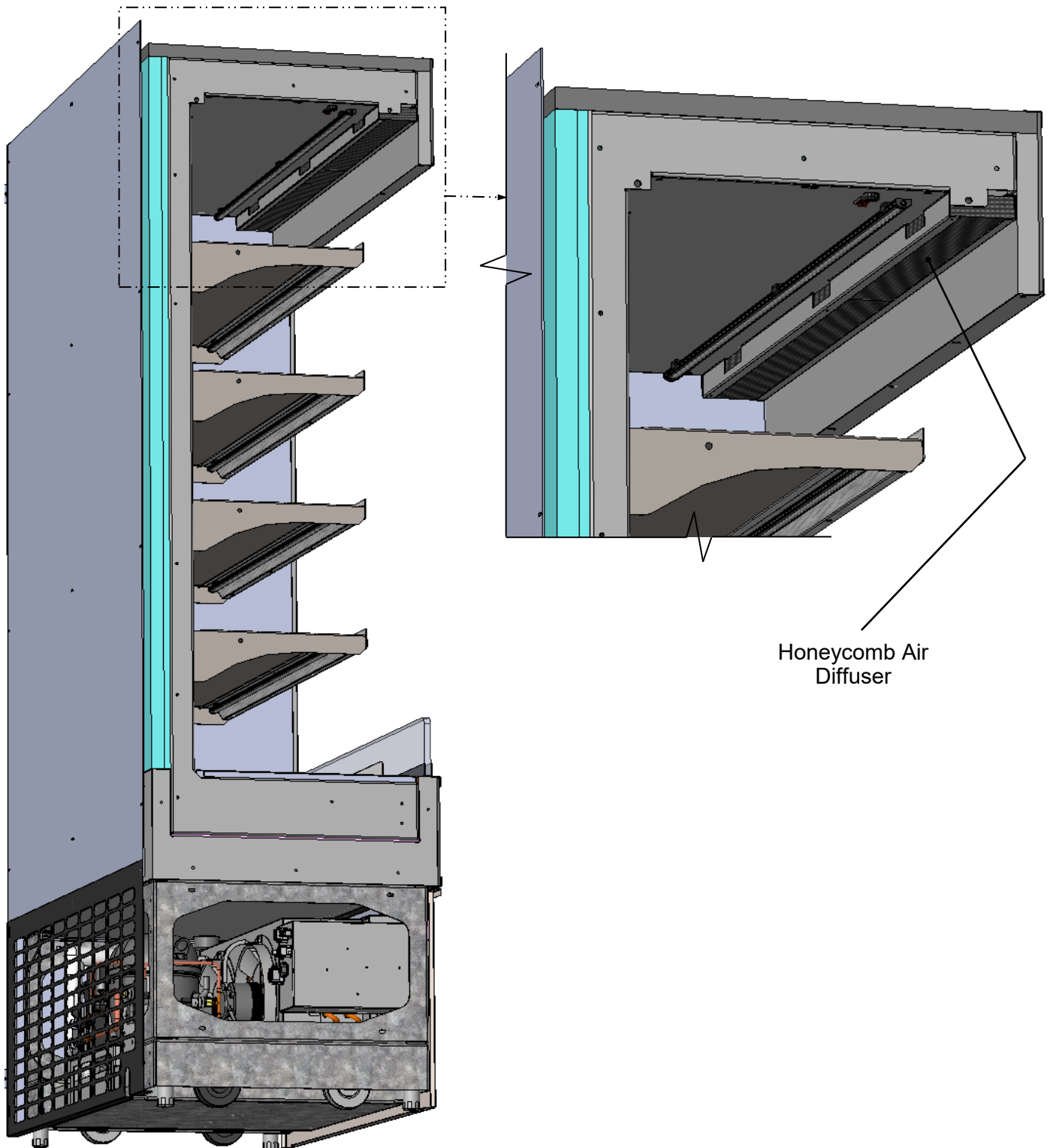

LED LIGHT FIXTURES

LED Style Light Fixtures

Removal of Faulty LED Lights:

- Contact Structural Concepts' Technical Service Department for replacement LED lights.
- Turn off LED light switch.
- To remove faulty LED light, follow these steps:
 - A. Disconnect plug from LED light.
 - B. Using both hands, grasp LED light assembly (with its magnetic mounting clips). Pull downward and off its shelf (or header).
 - C. Remove magnetic mounting clips from LED light by pressing against flange part of clip with thumb.

>> Note: Mounting clips MAY be riveted to shelf or header. In such instances, simply remove LED light from mounting clips by pressing against flange part of clips with thumb.

Replacement of LED lights:

- Attach magnetic mounting clips onto LED light.
- Adjust magnetic mounting clips so they are equally spaced on LED light.

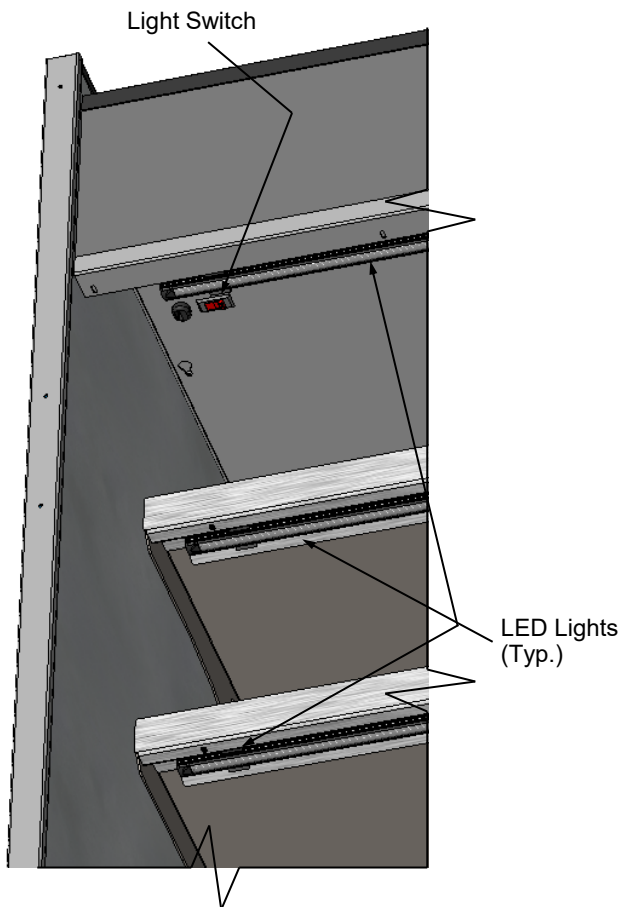

--- Case Front of Model B43C ---

- Reattach LED light assembly to its shelf/header.
- Position properly in shelf/header.

>> Note: If mounting clips are riveted to shelf (or header), attach by placing LED in base of clip and then snapping into clip at FLANGE SIDE.

- Press plug's barrel-shaped insert deep into LED light.
- Important: If plug is not inserted ALL THE WAY IN the LED light's orifice, the light may not energize. See "BAD" vs. "GOOD" insertion illustrations below.
- Turn LED light switch back on.

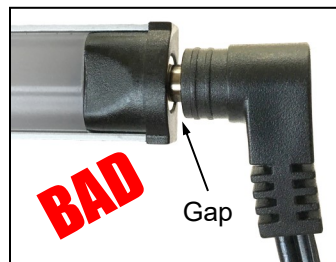
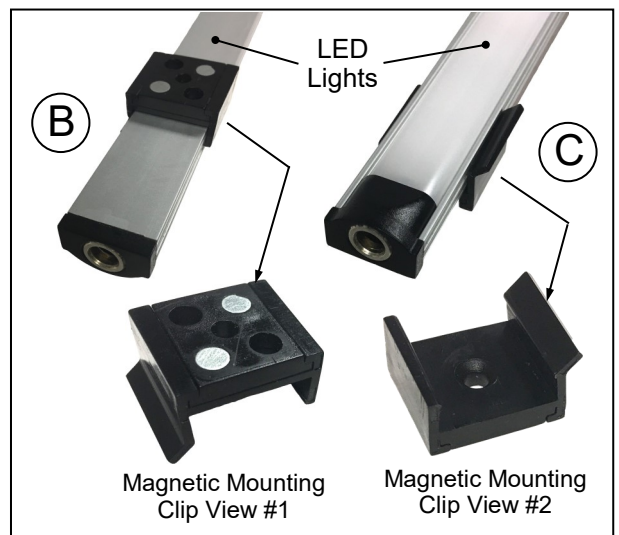
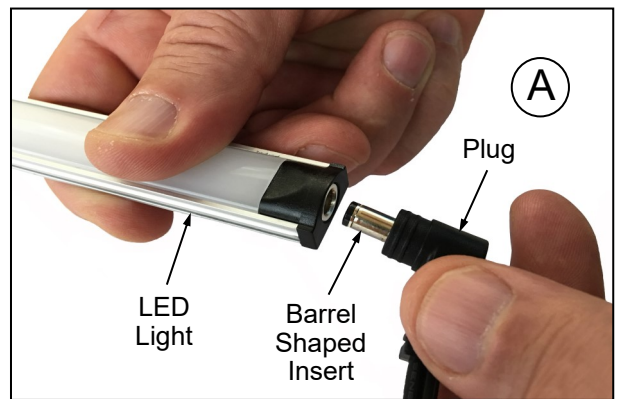

OPTIONAL ROLL-DOWN SECURITY COVER - MODEL B4732 ILLUSTRATED / YOUR MODEL MAY VARY

Roll Down Security Cover (Optional): Shown Extended

- Optional roll down security cover has two handles for grasping, lowering and raising.
- After roll-down cover is lowered, key may be turned clockwise to lock latch into strike bracket.
- Turn counter-clockwise to unlock.
- Keep keys in safe and secure place.

Views Below Shown Partially Disassembled With Transparent Components For Illustrative Purposes Only

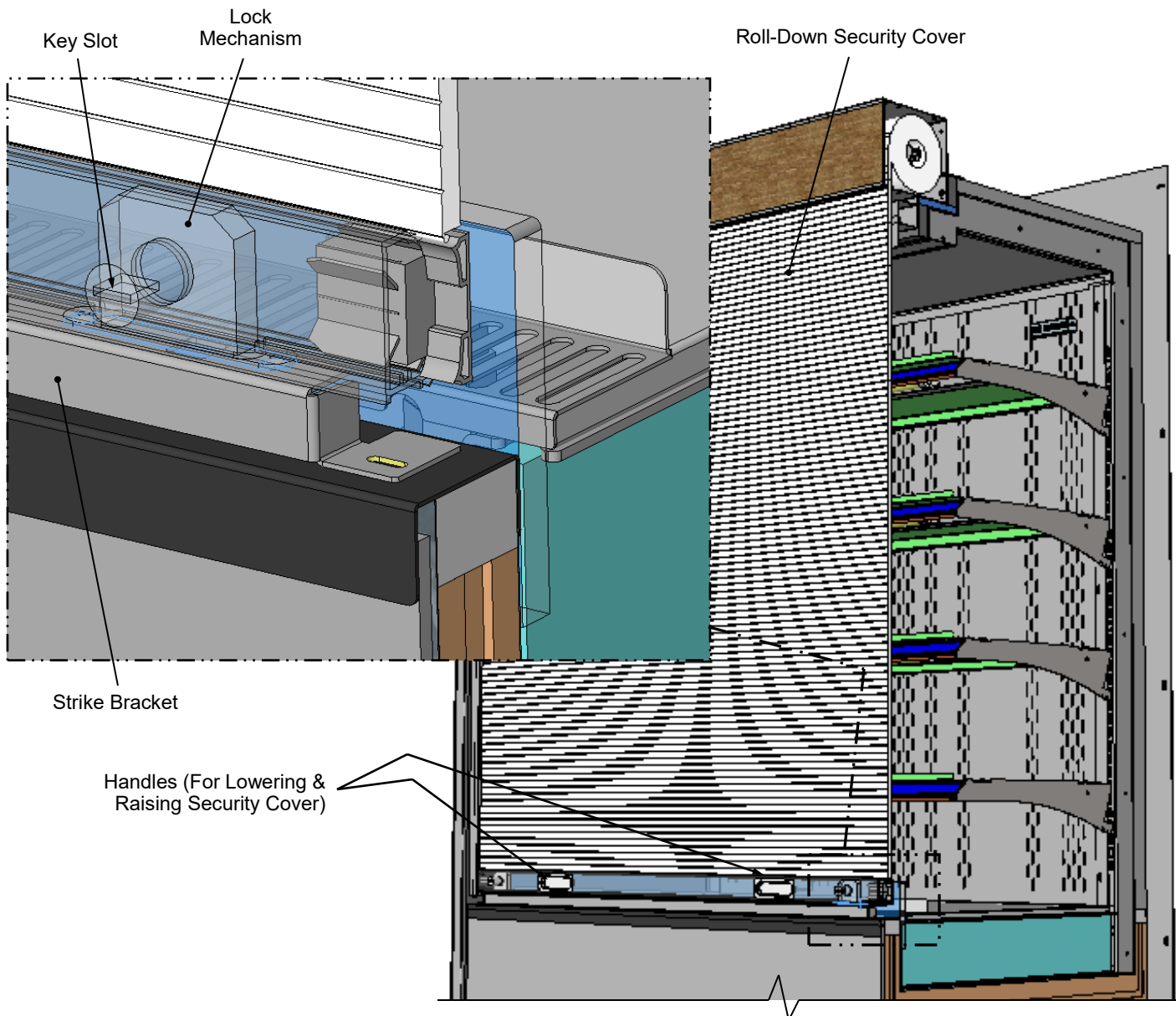
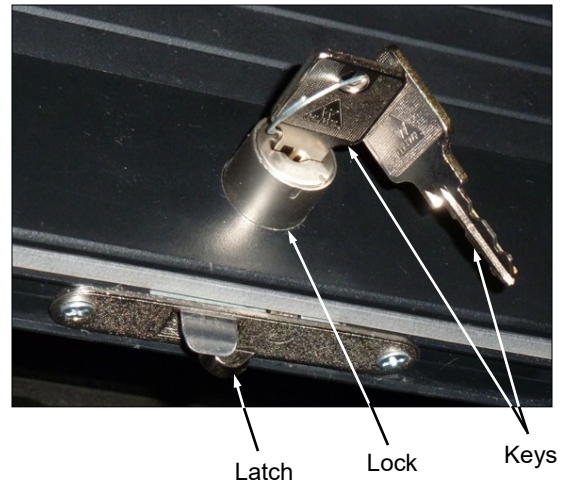

OPTIONAL DUAL REAR DOORS (WITH PERFORATED PLENUM DOORS) / B5932TM SHOWN

Dual Rear Doors (Optional):

- Illustration below has had optional roll-down security cover removed for illustrative purposes.

- Transparent rear doors have perforated plenum as part of each hinged door.
- Note: Transparent doors are not available on non-standard models.
- See illustrations below.

Note: Transparent Doors Are Not Available On Non-Standard Models

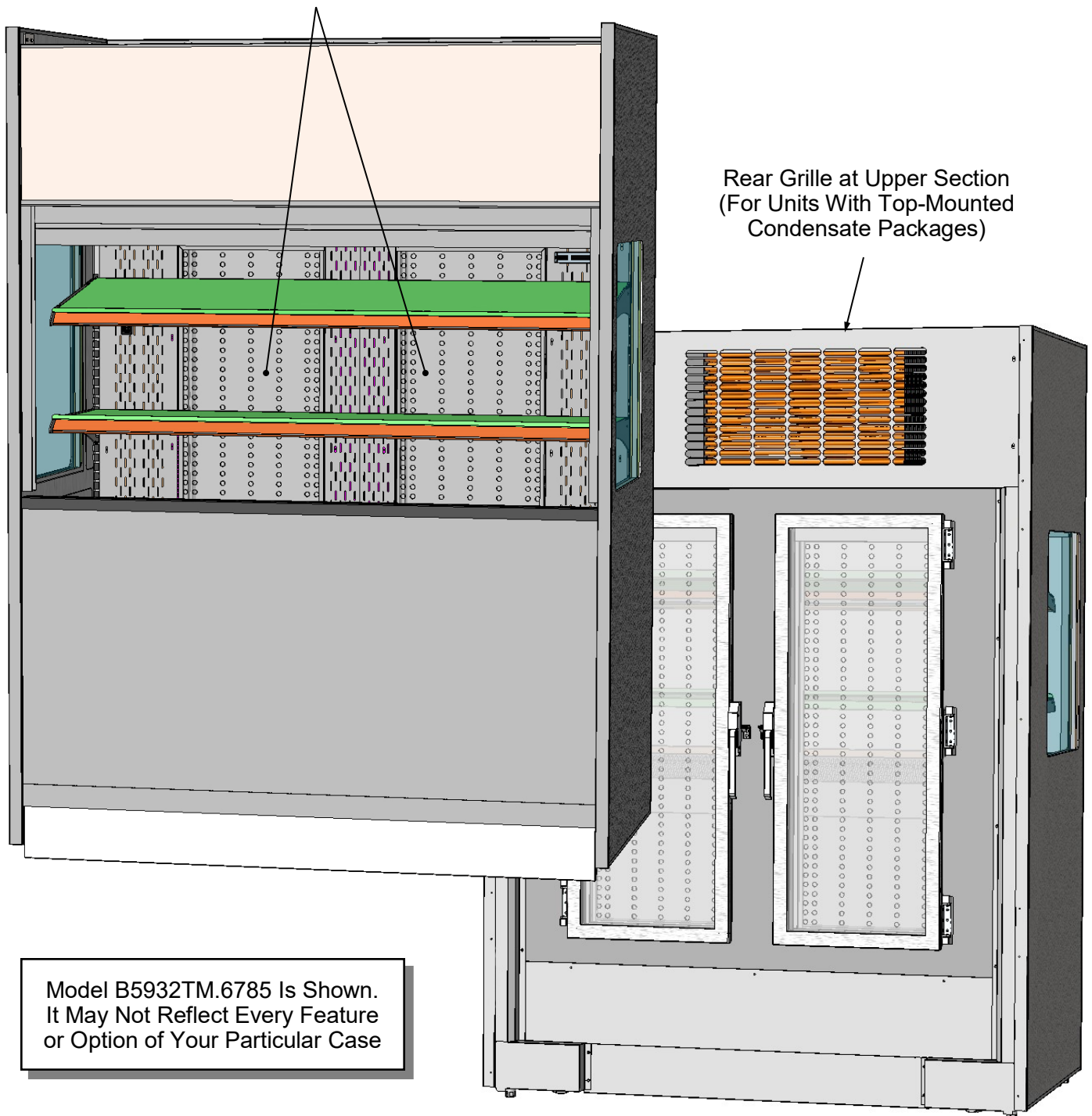

Model B5932TM.6785 Is Shown.
It May Not Reflect Every Feature
or Option of Your Particular Case

OPTIONAL SINGLE REAR DOOR (WITH PERF. PLENUM AS PART OF DOORS) / B3632TM SHOWN

Single Rear Door (Optional):

- Illustrations below show optional roll-down security cover intact AND removed for illustrative purposes.

- Rear door has stainless steel skin with stainless steel perforated plenum as part of door assembly.
- See illustrations below.

Model B3632TM Is Shown. It May Not Reflect Every Feature or Option of Your Particular Case

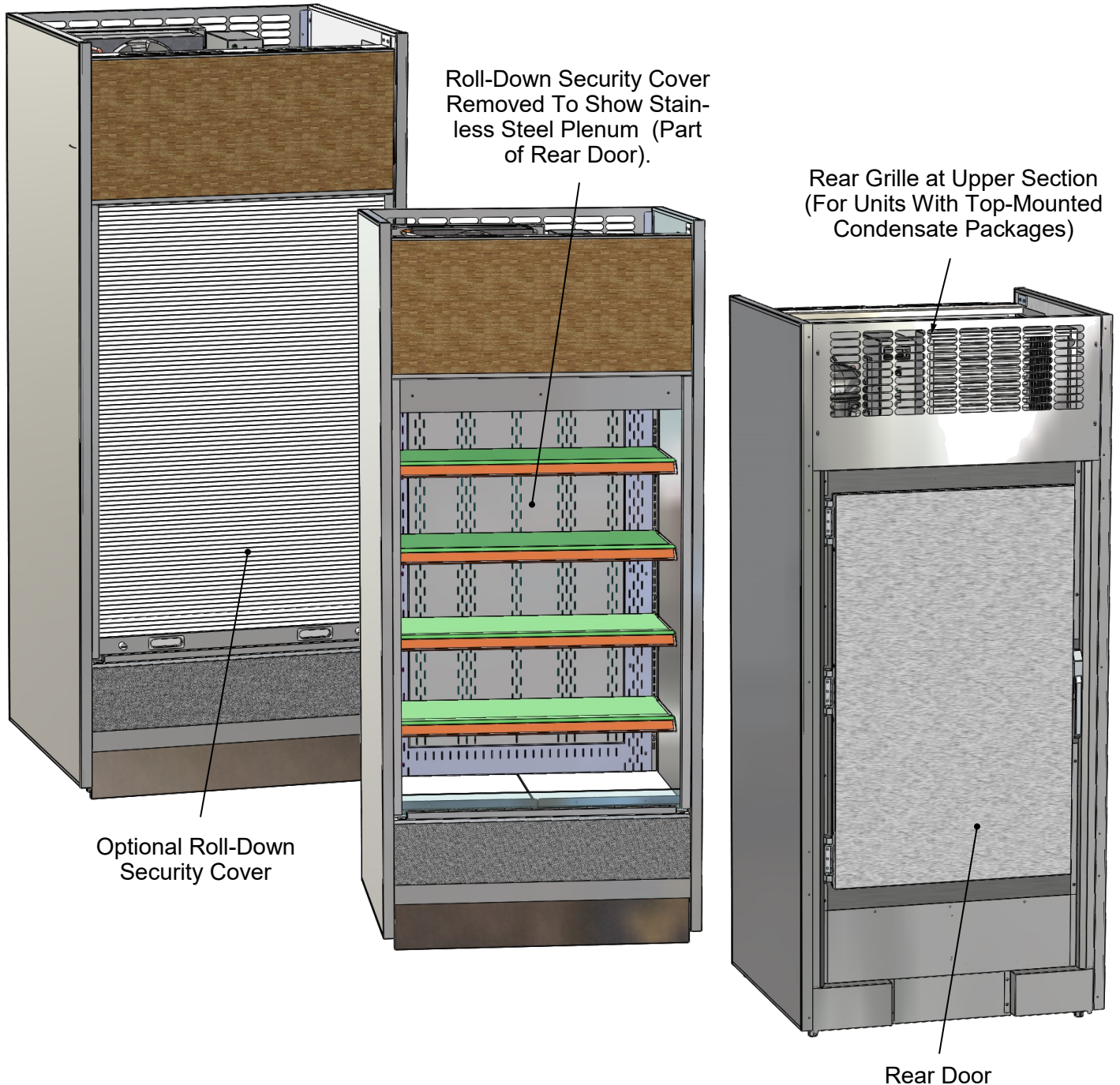

WALL SPACING / REAR GRILLE & VENTING PANEL (MAY NOT BE APPLICABLE TO YOUR MODEL)

Wall Spacing / Rear Venting (May Not Be Applicable To Your Model)

Venting Panel: Caution! Venting is an integral part of case temperature management. Case **MUST NOT be pushed up against wall if rear venting panel is not attached!**

Rear Grille: Rear grille may be removed (by removing 4 screws) for service or maintenance of condenser unit. Return rear grille to case rear when completed.

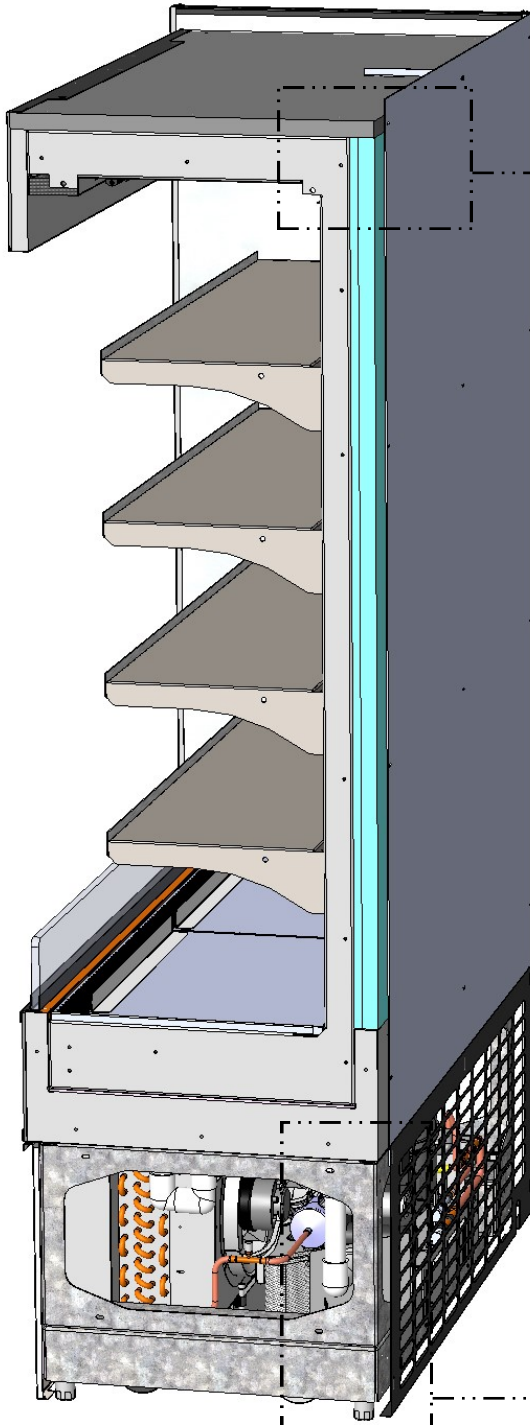

--- Case Right Side of Model B4524 ---

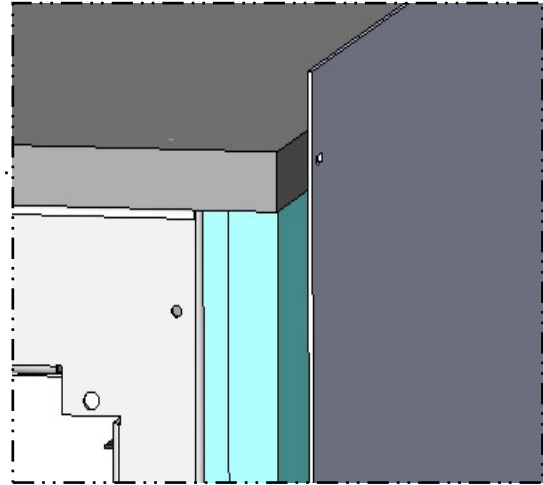

Approx. 1" Space Between
Rear Vent/Grille And Case

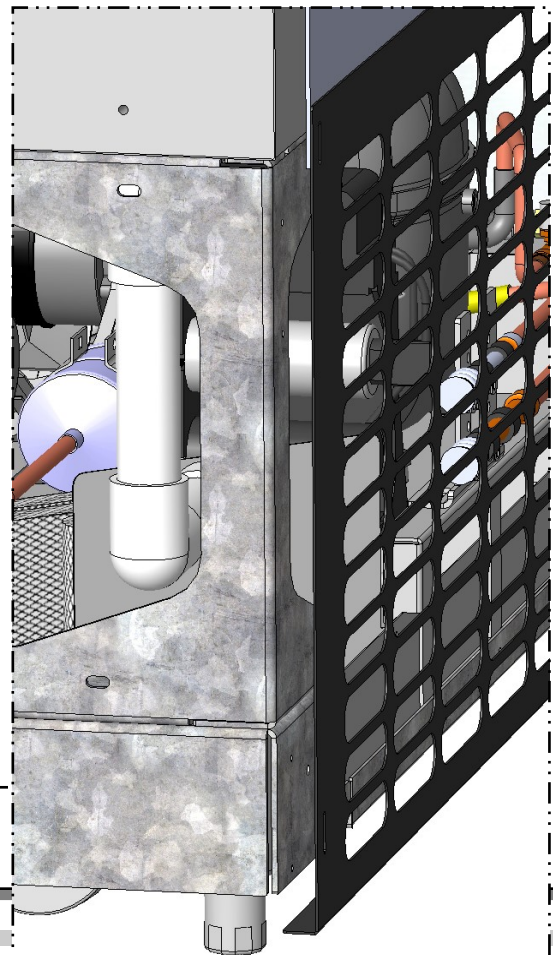

CONDENSATE PAN ACCESS: STANDARD UNITS

Condensate Pan Access

Warning! Disconnect power before providing maintenance and service to unit.

First, remove the front grille and slide out the condenser package. See **FRONT GRILLE ACCESS / CHECK CONDENSER PAN / REFRIGERATION ASS'Y / TURN ON POWER** section in this operating manual for instructions.

- Unplug the condensate pan from its outlet.
- Remove the two (2) screws holding the condensate pan foot to the condensate pan support (see illustration below).
- Carefully slide the condensate pan off from the condensate pan support.
- When done servicing or cleaning, return and reconnect in reverse order it was removed.

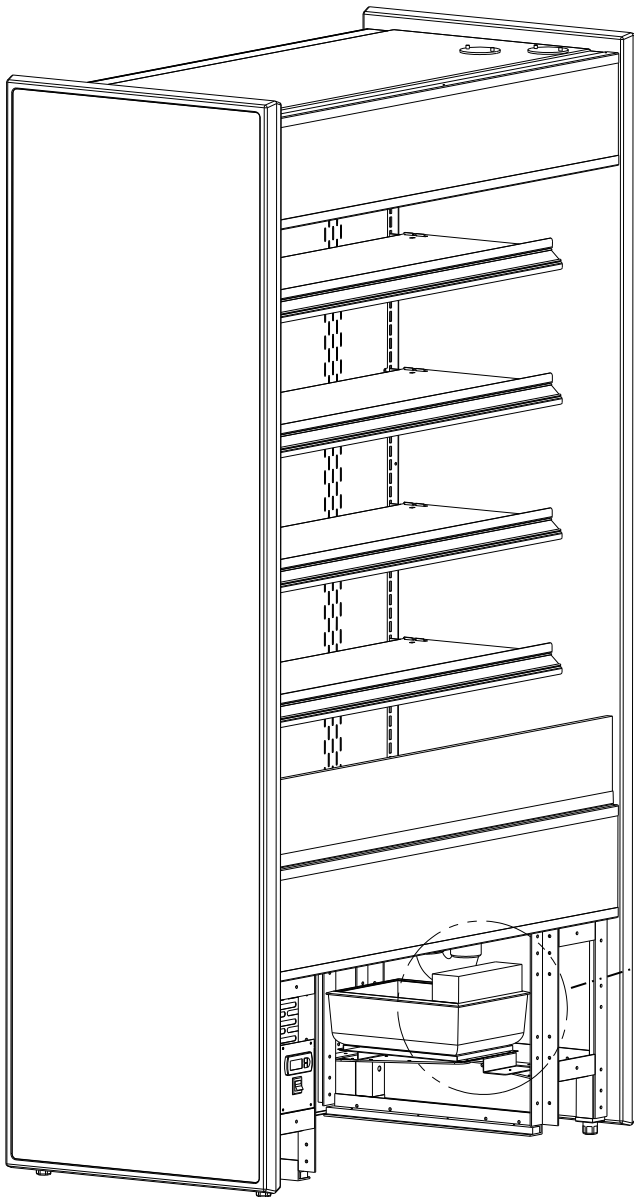

---- Case Front (Refrigeration Assembly Removed) ----

Note: Depending upon your particular refrigeration package, removable, electric-coil condensate pan may not be part of case. Cases with EnergyWise refrigeration packages DO NOT have a removable electric-coil condensate pan.

Two (2) Condensate Pan Screws (Connecting Pan Foot To Support)

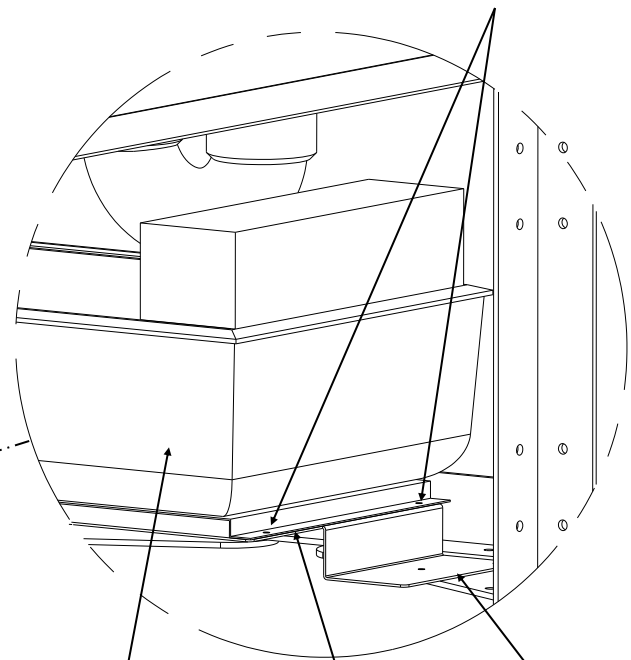

Condensate Pan

Condensate Pan Foot

Condensate Pan Support

CONDENSATE PAN ACCESS: REMOTE UNITS WITH CONDENSATE PANS ONLY

Condensate Pan Access and/or Removal

- **Caution:** Only trained service providers are to provide maintenance and service to unit.
- **Warning!** Disconnect power before providing maintenance and service to unit.
- To access, remove the front panel. Simply lift panel up and off (no screw removal is required).

- To service or clean, unplug the condensate pan from its outlet.
- Remove the screws holding the condensate pan foot to the condensate pan support (see illustration below).
- Carefully slide the condensate pan off from its support.
- When done servicing or cleaning, return and reconnect in reverse order it was removed.

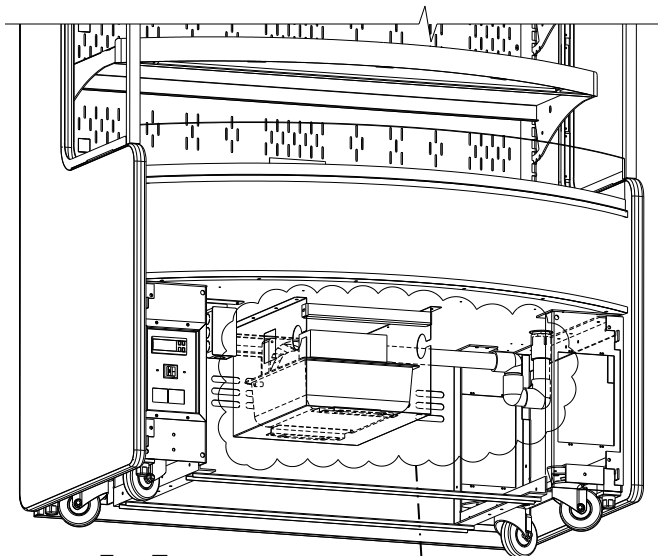

Fan To
Condensate Pan

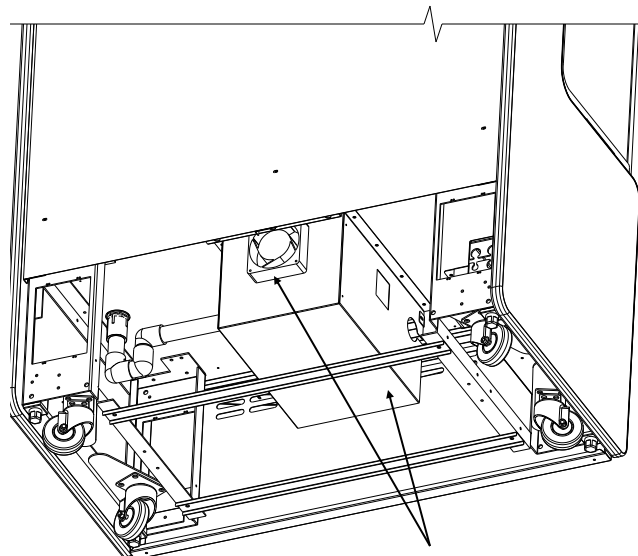

Case Rear View of Condensate
Pan Cover and Exhaust Fan
(Rear Panel Removed)

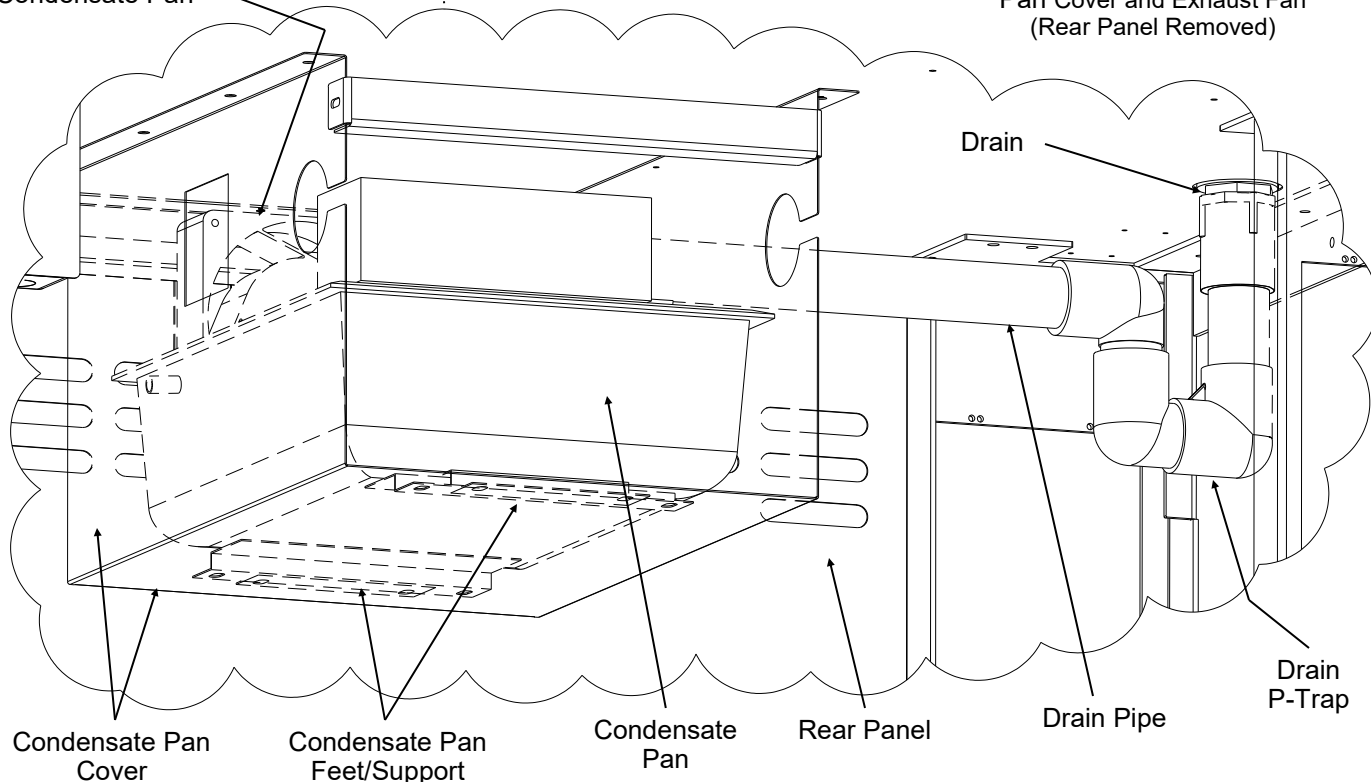

Condensate Pan
Cover

Condensate Pan
Feet/Support

Condensate
Pan

Rear Panel

Drain Pipe

Drain
P-Trap

**Self-Contained Hot Gas Loop
Condensate Packages**

- **Caution:** Only trained service providers are to provide maintenance and service to unit.
- **Warning!** Disconnect power before providing maintenance and service to unit.

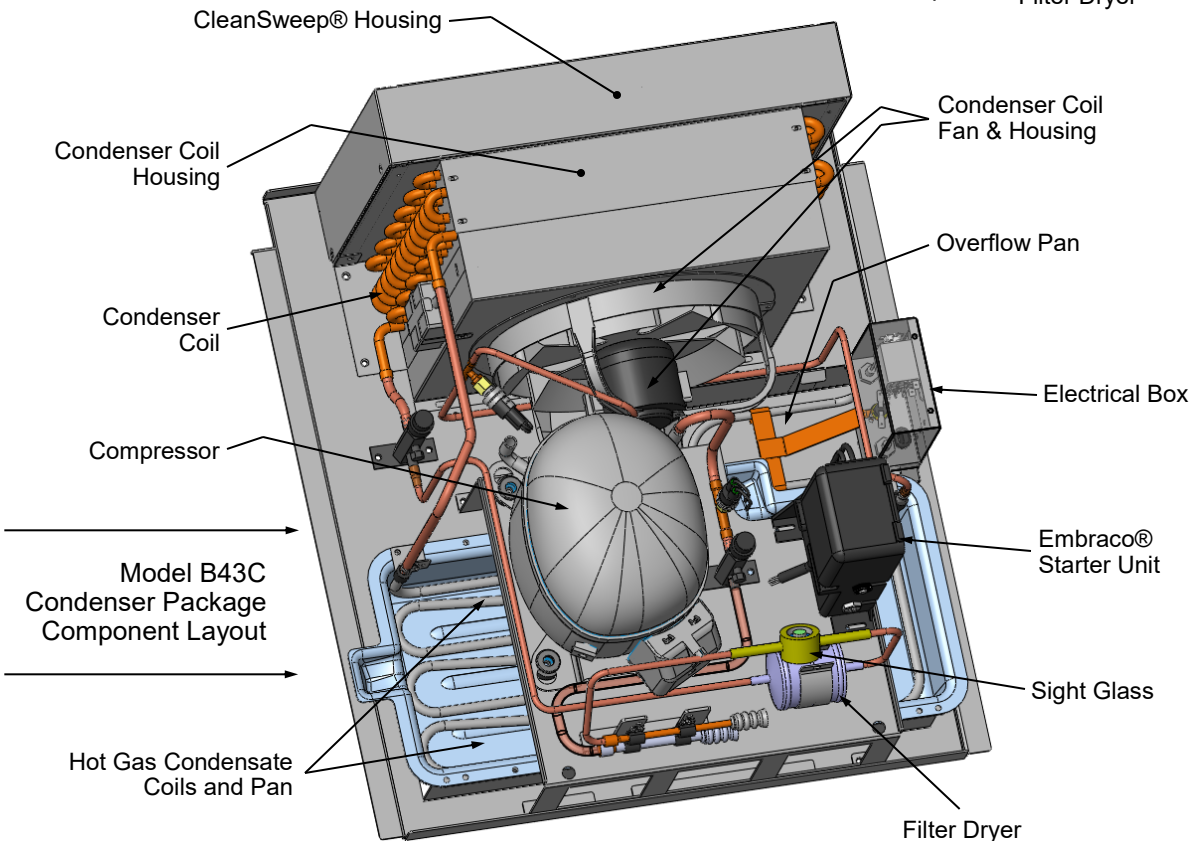
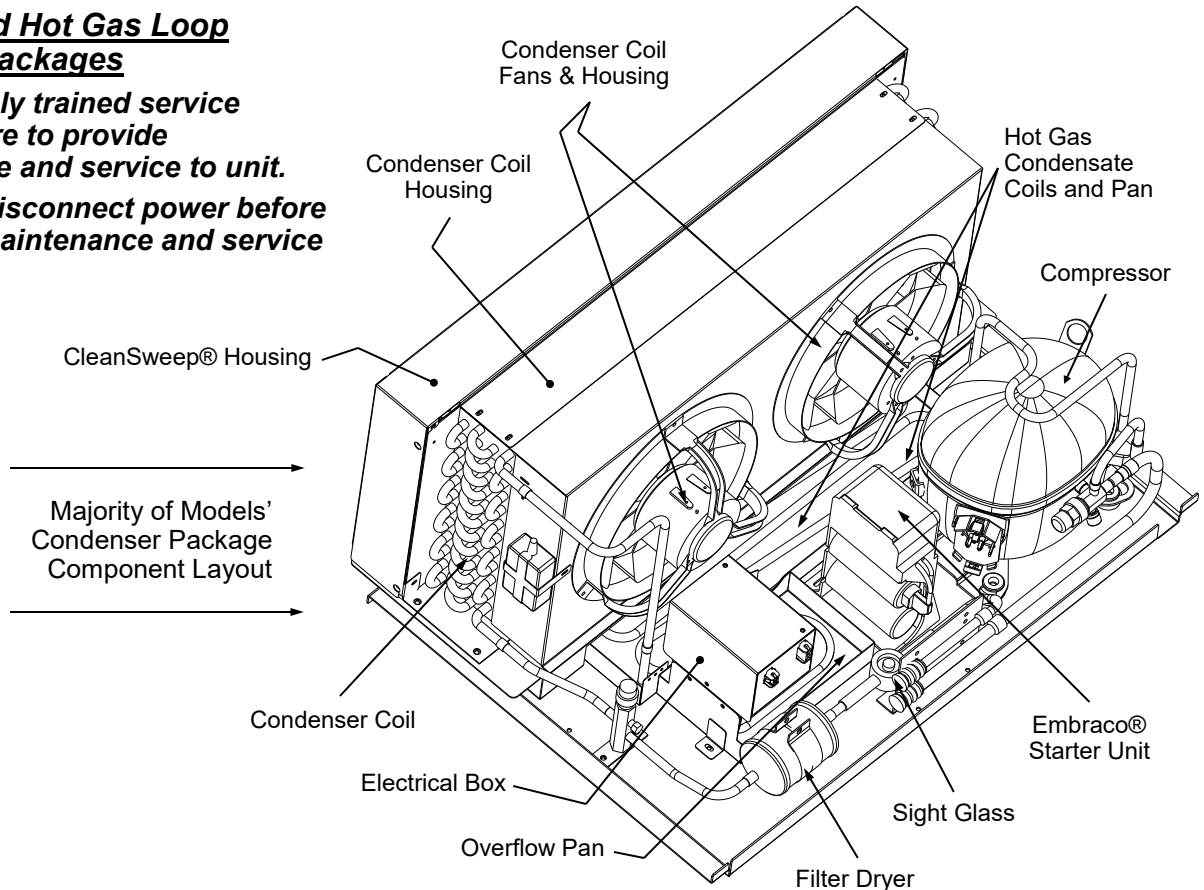

Self-Contained Hot Gas Loop Condensate Package

- **Caution:** Only trained service providers are to provide maintenance and service to unit.
- **Warning!** Disconnect power before providing maintenance and service to unit.

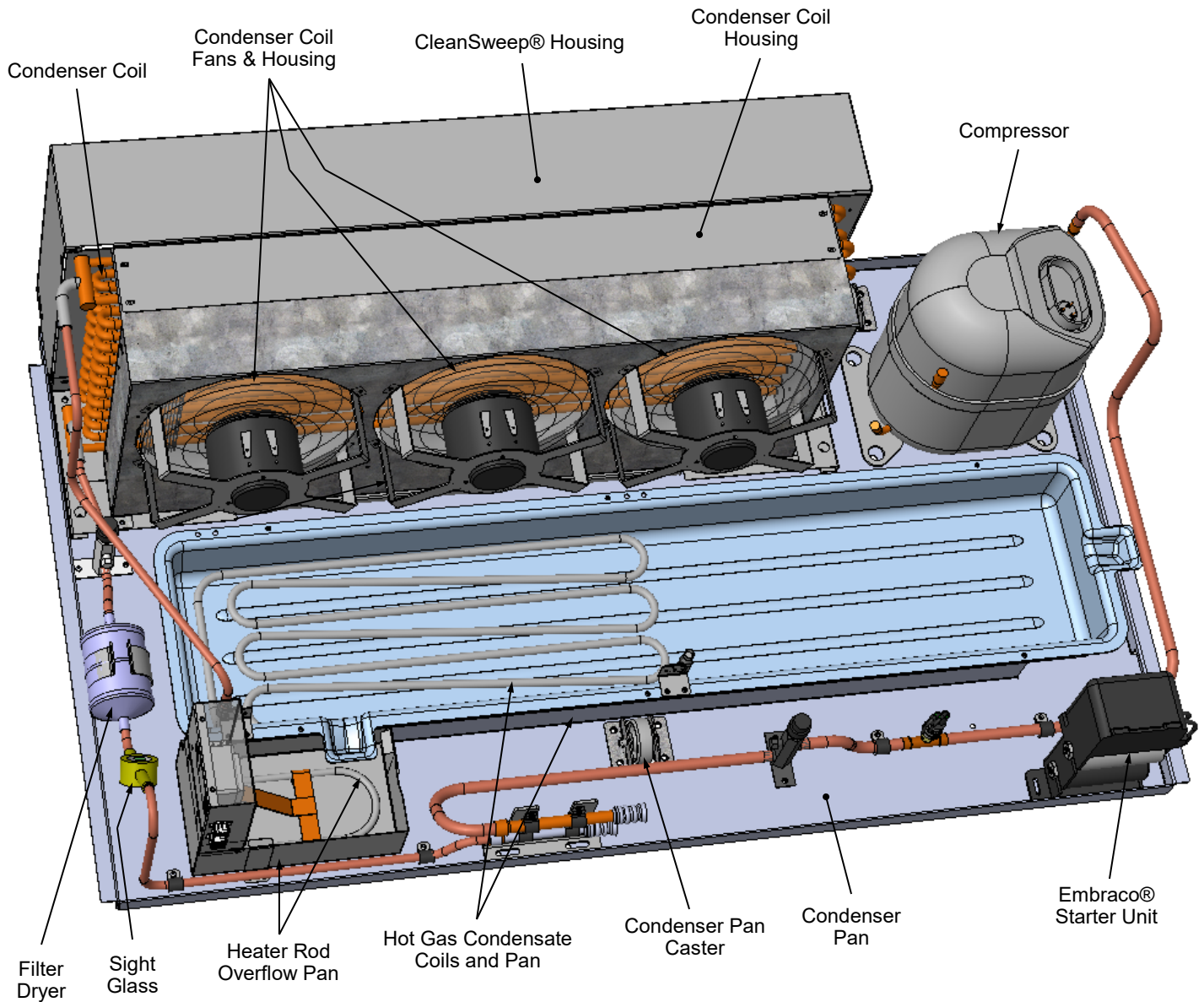

--- Model B6632SC.6241 Condenser Package Component Layout ---

SELF-CONTAINED HOT GAS LOOP CONDENSATE PACKAGE LAYOUTS - TOP MOUNTED

Self-Contained Hot Gas Loop Condensate Package - Top Mounted

- **Caution:** Only trained service providers are to provide maintenance and service to unit.
- **Warning!** Disconnect power before providing maintenance and service to unit.
- **Important!** See next page for underside pump/drain pan for top mounted units.

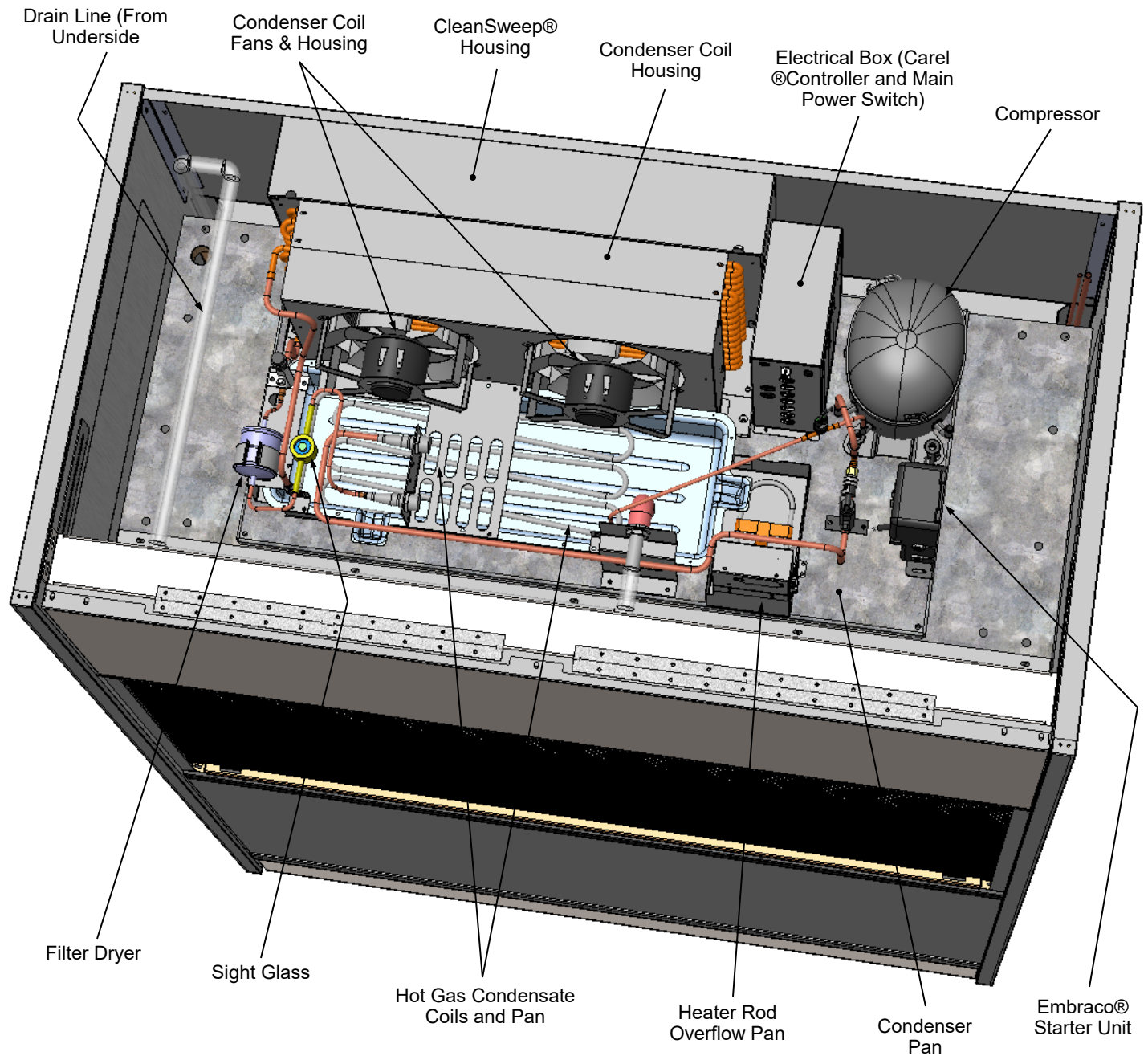

--- Model B5932TM.6785 Condenser Package Component Layout ---

UNDERSIDE PUMP/DRAIN UNIT (FOR UNITS WITH TOP-MOUNTED SELF-CONTAINED COND. PKGS.)

Underside Pump/Drain Unit (For Top-Mounted Self-Contained Condenser Packages)

- ***Caution:*** Only trained service providers are to provide maintenance and service to unit.
- ***Warning!*** Disconnect power before providing maintenance and service to unit.

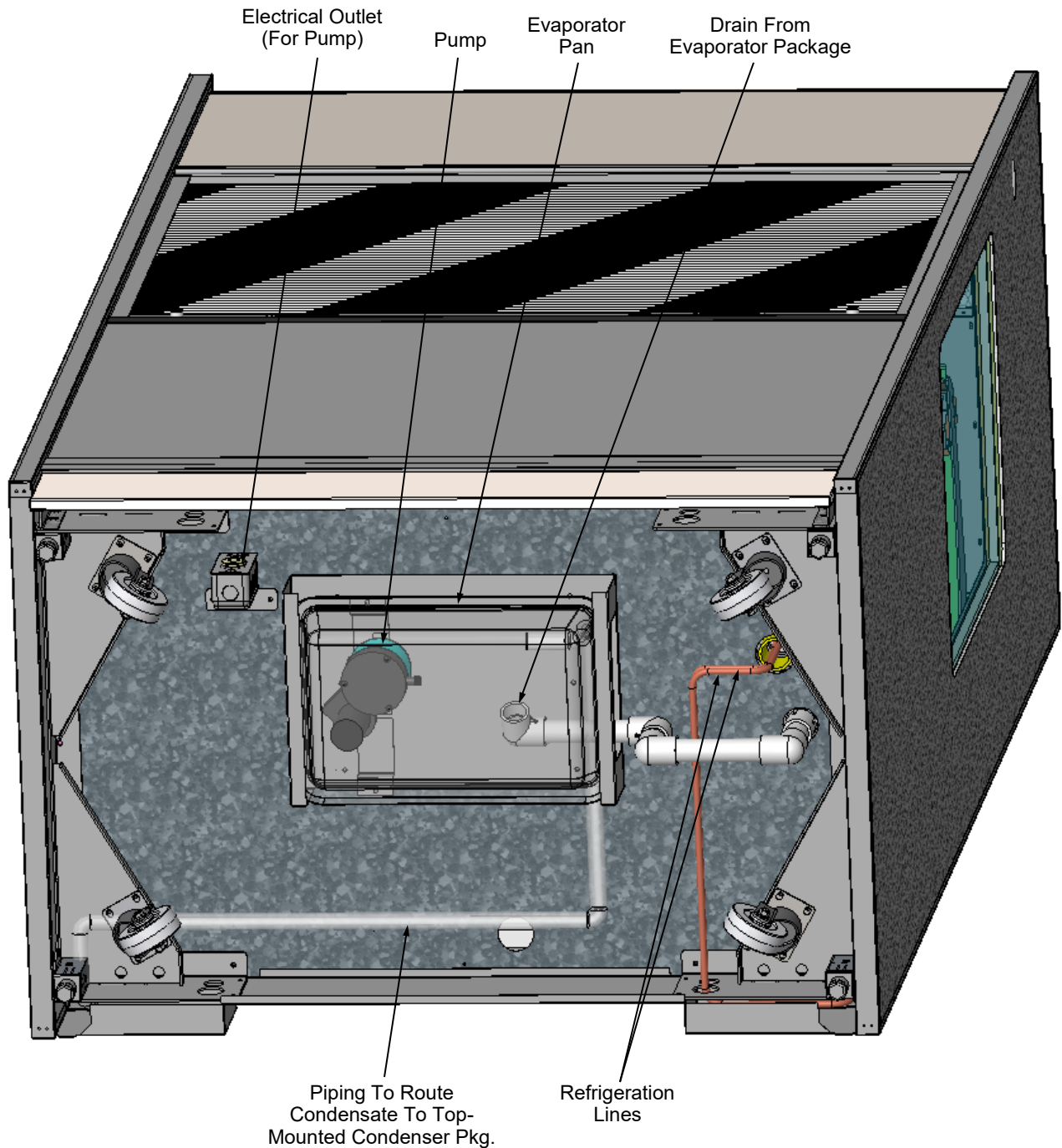

--- Model B5932TM.6785 Condenser Package Component Layout ---

LOAD LEVEL GUIDE / TEMPERATURE GUIDE (MODEL B42 SHOWN / APPLICABLE TO OTHERS)

LOAD LEVEL & TEMPERATURE GUIDE

CAUTION 1: TO PREVENT PRODUCT FROM FREEZING OR BECOMING OVERLY WARM, ALLOW AT LEAST 1" SPACE BETWEEN PRODUCT AND UPPER SHELF LIGHTS.

CAUTION 2: TO PREVENT PRODUCT FROM FREEZING OR BECOMING OVERLY WARM, DO NOT BLOCK AIR RETURN GRILLE WITH PRODUCT.

- IMPROPER PRODUCT PLACEMENT PREVENTS PROPER AIRFLOW CAUSING PRODUCT TO FREEZE OR BECOME OVERLY WARM.
- FOLLOW THESE PRODUCT PLACEMENT GUIDELINES TO MAINTAIN DESIRED PRODUCT TEMPERATURES.

NOTE: SEE VIEW AT RIGHT FOR PRODUCT TEMPERATURE RANGE AT FRONT vs. REAR OF CASE

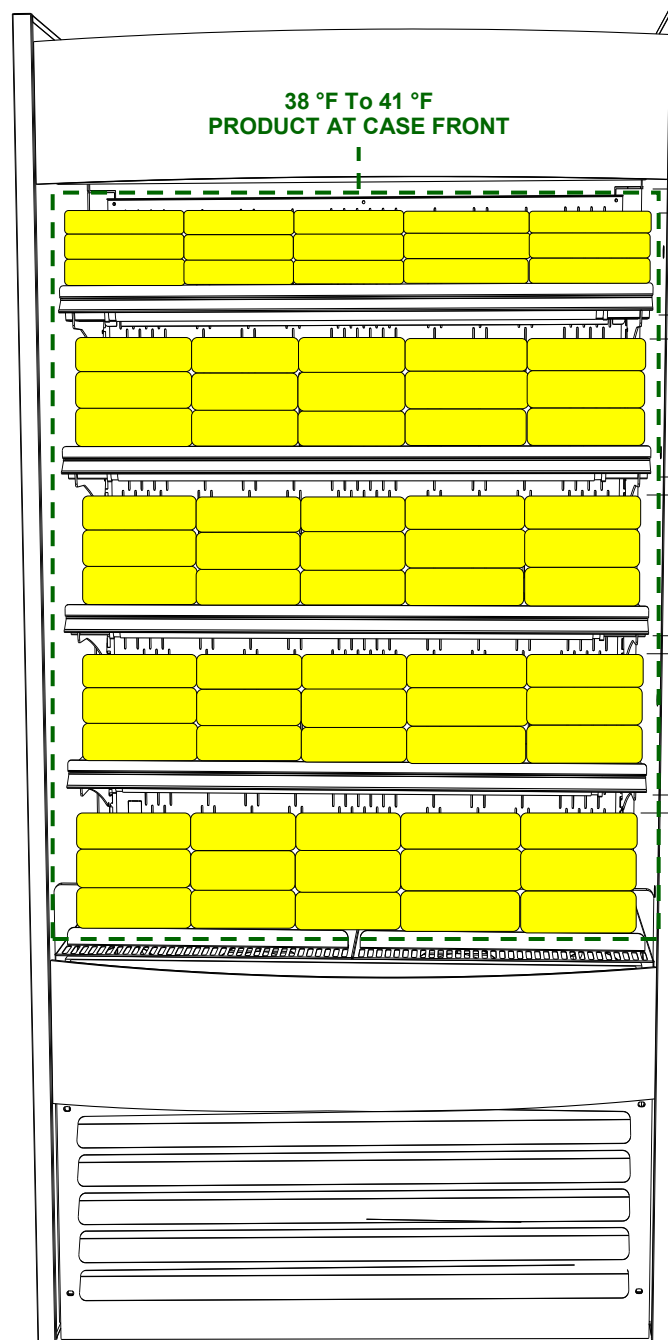

MODEL B42 FRONT SHOWN (APPLIES TO ALL MODELS). CASE IS FULLY ASSEMBLED AND FILLED WITH PRODUCT FOR ILLUSTRATIVE PURPOSES ONLY.

PACKAGED PRODUCT

TEMPERATURE RANGE

CAUTION 1: TO PREVENT PRODUCT FROM FREEZING OR BECOMING OVERLY WARM, ALLOW AT LEAST 1" SPACE BETWEEN PRODUCT AND UPPER SHELF LIGHTS.

CAUTION 2: TO PREVENT PRODUCT FROM FREEZING OR BECOMING OVERLY WARM, DO NOT BLOCK AIR RETURN GRILLE WITH PRODUCT.

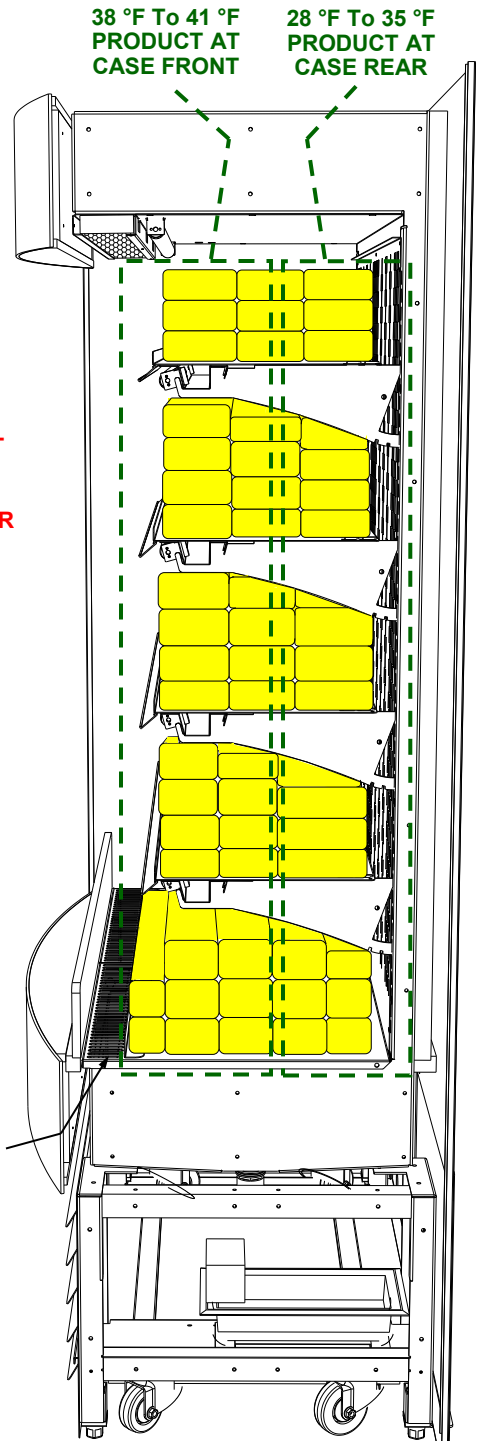

MODEL B42 SIDE SHOWN (APPLIES TO ALL MODELS). CASE IS PARTIALLY DISASSEMBLED AND FILLED WITH PRODUCT FOR ILLUSTRATIVE PURPOSES ONLY.

CLEANING SCHEDULE - PERFORMED BY STORE PERSONNEL

FREQ.	INSTRUCTIONS
Daily	Acrylic Air Deflectors: Clean with a warm water and mild soap solution and soft cloth. Never use ammonia-based cleaners (nor household or commercial window cleaner) on acrylic.
Daily	Shelves & Decks: Wipe off with moist cloth.
Daily	Glass Surfaces (Optional Rear Transparent Doors, Mirrors, etc.): <ul style="list-style-type: none"> • Clean with household or commercial glass cleaner. Dry with soft cloth or paper towel.
Weekly	Tub & Drain: Vacuum tub under decks. Clean with soap and water solution. Wipe dry with clean cloth. Keep drain free of debris to prevent clogging.
Weekly	Magnetic Condenser Coil Filter Option (Self-Contained Units Only): <ul style="list-style-type: none"> • This optional filter helps prevent dust particles from entering condenser coil. • It is accessible by removing front panel from case. • Clean magnetic condenser coil filter by following either of these steps: <ol style="list-style-type: none"> 1. To clean by hand, (without using dishwasher), remove magnetic condenser coil filter from case. Use a rag or soft-bristled brush to wipe off excess dust particles from filter. Submerge in warm, soapy water. Use soft-bristled brush to remove dust, dirt, grease and grime that may collect on filter. Rinse thoroughly. Skip to step #3. 2. As magnetic condenser coil filter is dishwasher safe, remove from case (no screw removal required) and use a rag or soft-bristled brush to wipe off excess dust particles from filter. Run in normal dishwasher cycle. Remove from dishwasher. Go to next step. 3. Dry with soft cloth or paper towel (as shown below) or allow to air dry. Replace.
Weekly	Rear Perforated Plenum (Either Stainless Steel or Acrylic): <ul style="list-style-type: none"> • Clean with a warm water and mild soap solution and soft cloth.
Monthly	Air Return Grille and Fan Shroud Area: See Illustration below. 1) Turn off power. 2) Remove decks from case. 3) Clean with moist cloth.

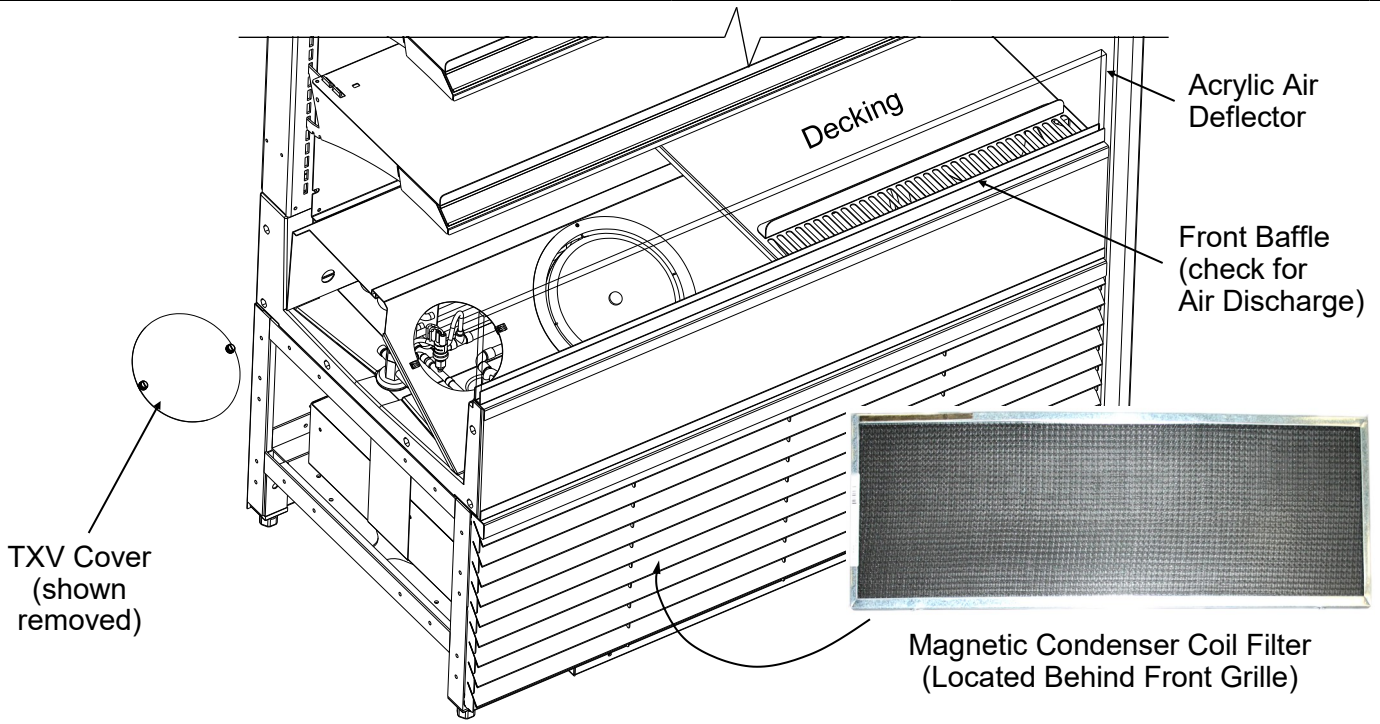

Above Illustration (With TXV at Customer-Left) is ONLY on Cases With Standard Refrigeration Package (With Standard Condensate Pan, etc.)

WARNING! TURN OFF CASE BEFORE PERFORMING PREVENTIVE MAINTENANCE!

QUARTERLY PREVENTIVE MAINTENANCE INSTRUCTIONS

Tub, Coil, Drain, Fan Blades, Motors, Brackets:

Caution! Do Not Clean or Perform Service On Unit While It Is Energized!

1. Remove front panel (to access controls). No screw removal is required. Place in safe place away from foot traffic.
2. Turn off main power switch (located near Carel® Temperature Controller).
3. Remove both deck pans/sub-deck. Place in safe place away from foot traffic.
4. Remove electrical tape (if any) and disconnect power cord that energized fan panel.
5. Grasp underside of fan shroud assembly (above trough). Lift upward and away from case. Place in safe place away from foot traffic.

Cleaning Process:

- Use vacuum to remove excessive residue AND to remove dust in coil.
- Use clean cloth and/or nylon brush with warm water and mild soap solution to clean tub, drain, trough, TXV, lines, solenoid, coil & coil tubes. See enlarged view of components to be cleaned (lower-right).
- Remove debris that may clog drain.
- Wipe down fan blades, motors and brackets with moist cloth.

Returning Components / Restoring Power To Case:

- Replace/reconnect components in reverse order they were removed or disconnected.
- Turn main power switch back on. Check that fans are operational.

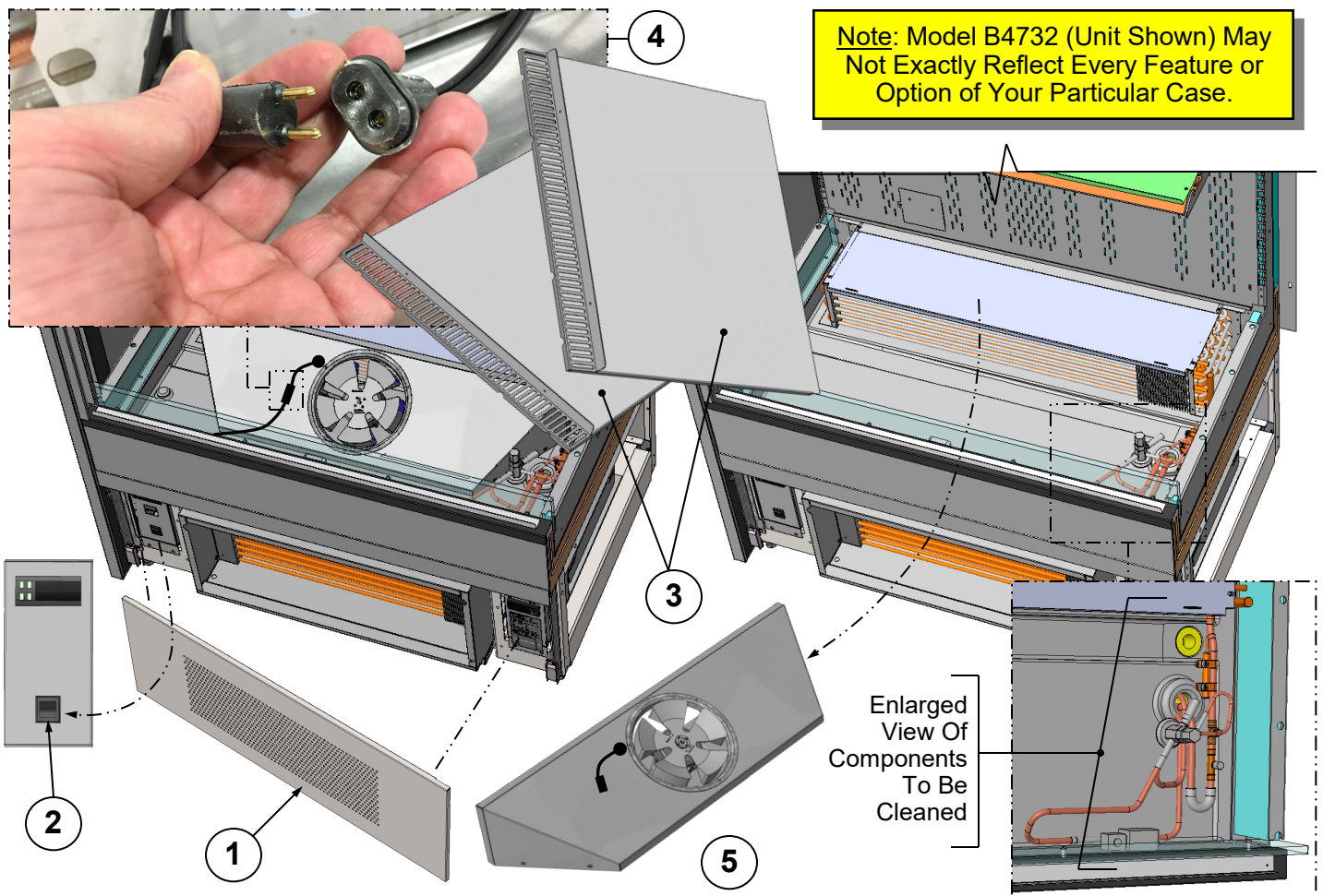

WARNING! TURN OFF CASE BEFORE PERFORMING PREVENTIVE MAINTENANCE!

QUARTERLY PREVENTIVE MAINTENANCE INSTRUCTIONS

Under Case Cleaning:

Whenever refrigeration assembly is removed from underside of case, vacuum (or broom) under case to remove all dust, debris and dirt that may collect.

Condenser Coil Fins / Refrigeration Assembly Without Evaporator Pan:

Warning! Disconnect power from case before beginning process!

- A. Remove front grille (by removing thumbscrews).
- B. Slide out refrigeration assembly.
- C. Use vacuum (in suction mode) and brush to dislodge and remove dust both in and on coil fins.
- D. Place damp rags around condensing fan motor brackets to collect airborne dust.
- E. Switch vacuum to blow mode to blow air through condenser coils and into damp rags on fans. Blow entire surface of condensing coil to assure that all entrenched dust is removed. Caution! Coil fins are sharp!
- F. While refrigeration assembly is out from under case, use a moist cloth to wipe off dust & debris that collects on various parts (fans, sight glass, overflow pan, etc.).
- G. Slide refrigeration assembly back under case.
- H. Replace front grille to case (reattach with thumbscrews).

See illustrations below.

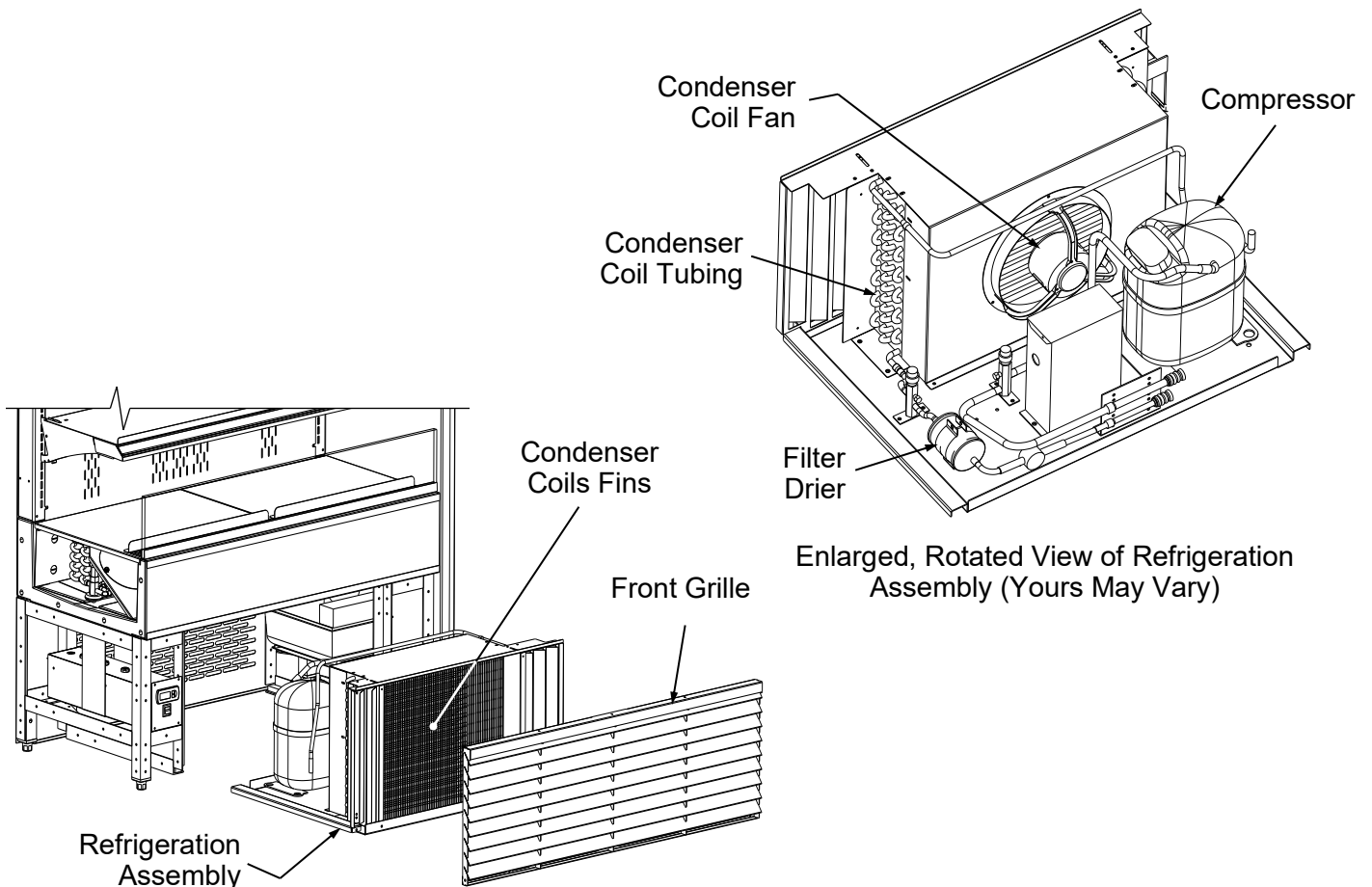

WARNING! TURN OFF CASE BEFORE PERFORMING PREVENTIVE MAINTENANCE!

PREVENTIVE MAINTENANCE	QUARTERLY PREVENTIVE MAINTENANCE INSTRUCTIONS
<p>Case Interior</p>	<p><u>Refrigeration Assembly With Condensate Pan:</u></p> <p><i>Caution! You must turn main power switch off before cleaning!</i></p> <ul style="list-style-type: none"> • Remove front grille. Turn main power switch off. • Slide refrigeration package out from under case. • Remove wicking material (if any). • Use a scrub-brush and a non-corrosive de-scaling solution (to remove calcium, lime and rust) from condensate pan. Clean hot gas loop (for EnergyWise units) or electric coil (for standard units). Follow instructions as to proper dilution, safety precautions and scrubbing method. • After thoroughly cleaning pan with scrub-brush and solution, rinse thoroughly with clean water (in spray bottle) and wipe dry with sponge or paper towel. • Use moist cloth to wipe off dust & debris that collects on various parts (fans, sight glass, overflow pan, etc.). • Return wicking material to mounting brackets. If wicking material is tattered, torn or disintegrating, replace with new. If wicking material is not available, contact Structural Concepts. See toll-free number at last page of operating manual. • Slide condenser package back under case. • Return front grille to case.

Note: Hot Gas Loop
Condensate System Shown.
Standard Electric Coil
Condensate Pans Have
Slightly Different Layout.

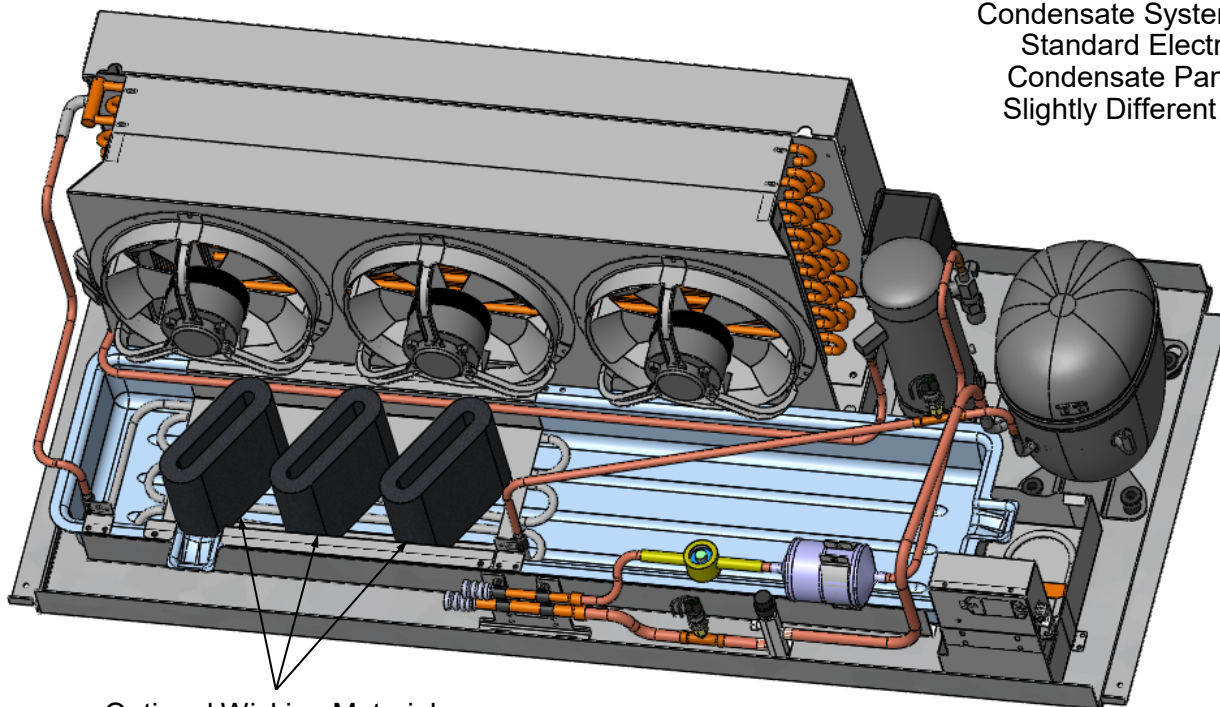

Optional Wicking Material
(Shown For Illustrative Purposes Only)

PREVENTIVE MAINTENANCE	QUARTERLY PREVENTIVE MAINTENANCE INSTRUCTIONS
Case Interior	<p>Honeycomb Air Diffuser:</p> <p>A. Wedge a non-metallic device of suitable strength (such as a ballpoint pen) between honeycomb and its housing. <u>Caution!</u> Use care not to dislodge the heating wire (that prevents condensation on the honeycomb retainer).</p> <p>B. Apply pressure to collapse honeycomb to pull it out of honeycomb retainer.</p> <p>C. Carefully pry downward and away from the honeycomb retainer.</p> <p>D. Use brush to reach in and, with outward sweeping motion, pull any crumbs or residue out of honeycomb area.</p> <p>> Clean honeycomb with warm water and soap solution. Submerge if necessary. Use brush to dislodge stubborn or sticky residue. Dry by using vacuum's blow mode.</p> <p>E. After honeycomb has been thoroughly cleaned and dried, squeeze honeycomb to allow it to fit into the honeycomb retainer.</p> <p>F. Carefully slide honeycomb into place.</p> <p>G. Adjust honeycomb so it fits <u>flat</u> against retainer (not be wavy or out of position).</p>

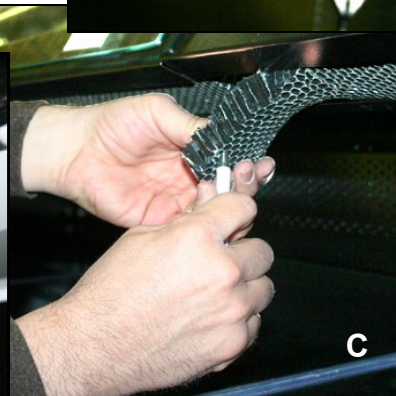
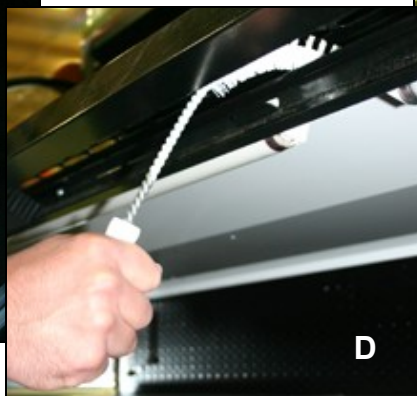
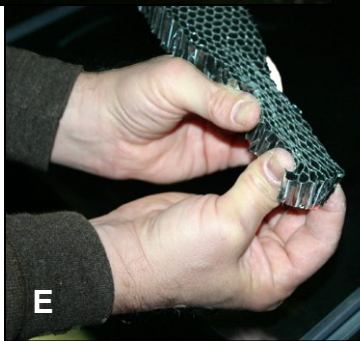
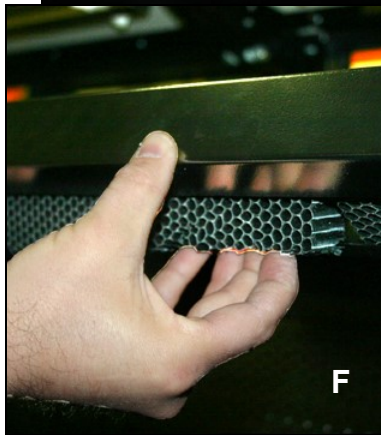
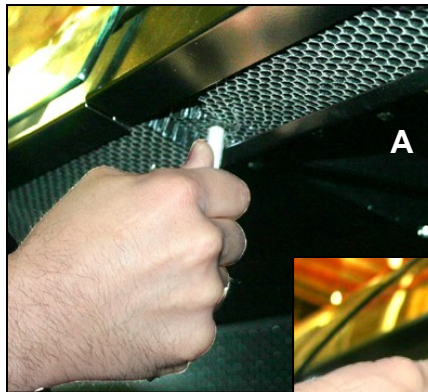

ANNUAL PREVENTIVE MAINTENANCE INSTRUCTIONS

Optional Clean Sweep® Condensing Coil Cleaner:

Important! Disconnect power from case before cleaning the Clean Sweep® Condenser Coil Cleaner!

- Remove front grille (by removing 4 screws).
- Slide/roll out condensing unit assembly.
- Remove the four (4) screws holding Clean Sweep® rails intact.
- Remove the Clean Sweep® rail.
- Wash rail and brushes in hot water and mild soap solution.
- If brushes are worn, they must be replaced. Call Technical Service Department to replace. Toll-Free number is listed at end of manual.
- **Caution! Coil fins are sharp. Handle with care!**
- Reattach Clean Sweep® rail to condensing unit (4 screws).
- Slide/roll condensing unit assembly back under case.
- Replace front grille to case in same manner it was removed.
- See photos below.

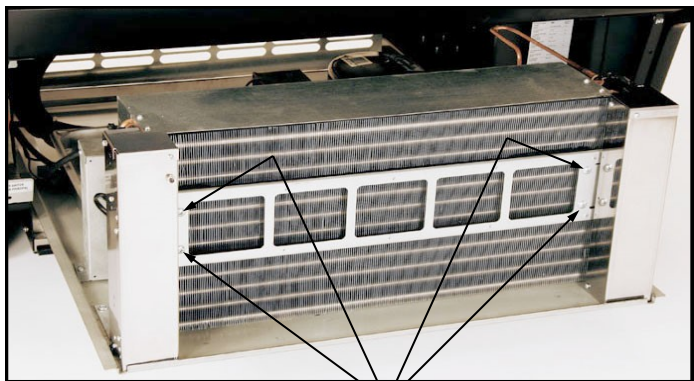

(4) Screws



Rail

Brushes

--- Above photos are taken after front grille has been removed from case ---

CONDITION	TROUBLESHOOTING
Case Not Lining Up	See Installation section in this manual for instructions on properly aligning case (alongside other cases) and adjusting levelers.
Water Is On The Floor	<p>Caution! Water on flooring can cause much damage! Until cause is determined (and repaired), follow these procedures:</p> <ul style="list-style-type: none"> • Use wet-dry vacuum (or mop & bucket) to remove standing water. • Use 'catch pans' for water to drain into. Swap out regularly until case has completely drained. • Note: See <i>Drain, Hose and Bracket Placement Illustrations</i> sheet in this manual for views of different condensate systems used in display cases.
	Check that the drain trap is free of debris.
	Check that the drain hose is correctly positioned over condensate pan (or floor drain, for remote units).
	Check store conditions. To prevent condensation in Type I environments, maximum conditions are to be 55% humidity / 75 °Fahrenheit. For Type II environments, maximum conditions are to be 55% humidity / 80 °Fahrenheit. See serial label (at case rear near main power switch) for NSF® Type of your case.
	Check condensate pan float for proper operation (electric condensate trays).
	Check that condensate pan is properly plugged in or connected.
	<p>Caution! Condensate pan may be malfunctioning. If so, water will overflow pan and seep onto flooring causing damage! Until condensate pan is functioning (or is replaced), follow these procedures:</p> <ul style="list-style-type: none"> • Use wet vacuum (or mop & bucket) to remove standing water. • Use 'catch pans' for water to drain into. Swap out regularly until case has completely drained.
	<p>Caution! Disruption of power can cause water to overflow pan and seep onto flooring causing damage! Check that power to case is constant. Until power is restored, follow these procedures:</p> <ul style="list-style-type: none"> • Use wet-dry vacuum (or mop & bucket) to remove standing water. • Use 'catch pans' for water to drainage. Swap out regularly until drainage of case is complete (or until power is restored). • When power to case is restored, condensate pan should function properly and water will no longer overflow onto flooring.
	<p>Caution! Wicking material (if any) on your particular hot gas loop condensate tray may be dirty or worn and need replacement.</p> <ul style="list-style-type: none"> • Slide condensate package out from under unit. • After refrigeration system has been carefully slid out, replace wicking material with new. If wicking material is not available, contact Structural Concepts. See toll-free number at last page of this operating manual. • Note: See PREVENTIVE MAINTENANCE (QUARTERLY) - PERFORMED BY TRAINED SERVICE PROVIDER - 3 of 5 section in manual for wicking material illustration.

CONDITION	TROUBLESHOOTING
Fan Emits Excessive Noise	Check that the case is aligned, level and plumb.
	Check evaporator fan for cleanliness.
	Unplug/power off fan motors. Check motor shaft for bearing wear.
	Check that fan motors are securely mounted in brackets.
	Verify that fan blades are securely mounted to fan motor.
	Check that nothing is preventing blade rotation.
	Check that the fan shroud is properly secured.
Fans Are Not Working	Check that the MAIN power switch is on.
	Check that fans are plugged in at the fan shroud.
	Check for foreign material obstructing fan performance.
	Check that fan blades freely rotate within fan shrouds
	Check that power is going to fans
	Check that fan wiring is connected on terminal blocks.
Digital Control Display Is Blank	Check that the MAIN power switch is on.
	Check the circuit breaker box for tripped circuits.
System Not Operating	Check that the utility power is on.
	Check that the MAIN power switch is on.
	Check the circuit breaker box for tripped circuits.

CONDITION	TROUBLESHOOTING
Case Lights Are Not Working	Check that light switch is in the <i>on</i> position.
	Check that ALL of the light cords and plugs are properly connected. See FLUORESCENT LIGHT FIXTURES and LED LIGHT FIXTURES section in this manual for specifics.
	Service Technicians Only: Check voltage at LED drivers. If voltage is entering but not exiting, LED driver may be faulty.
Control Display Is Flashing	See your case's serial label for your model's specified settings. See SERIAL LABEL LOCATION & INFORMATION LISTED / TECH INFO & SERVICE for label location, etc.
Case Is Not Holding Temperature	If a large amount of warm product was added to the case, it will take time for the temperature to adjust. Unit needs product to be pre-chilled.
	Temperature changes during defrost mode but will return to normal. Fourth LED will indicate defrost cycle in progress.
	Check that case is not in sun or near a heat or air-conditioning vent. See OVERVIEW / TYPE / COMPLIANCE / WARNINGS / PRECAUTIONS / WIRING / PLUGS section in manual for adverse conditions/spacing issue parameters.
	If case is located near front doors, temperature fluctuation can hinder unit's ability to maintain temperature. See OVERVIEW / TYPE / COMPLIANCE / WARNINGS / PRECAUTIONS / WIRING / PLUGS section in manual for adverse conditions/spacing issue parameters.
	Check that condenser coil air filter (attached to rear grille) has been cleaned. See GENERAL CLEANING (TO BE PERFORMED BY STORE PERSONNEL) section in operating manual for instructions.
	Check that condenser coil has been cleaned.
	Check air return grilles for obstructions.
	Check sight glass for flashing and/or low charge.
	Check Set Point Temperature; it may be adjusted too high.
Condensing Unit Is Not Operating	Check that the power is turned on.
	Determine if temperature controller settings are properly set. See your case's serial label for your model's specified settings. See SERIAL LABEL LOCATION & INFORMATION LISTED / TECH INFO & SERVICE section in manual for label location, etc.

TROUBLESHOOTING - CONDENSING SYSTEM (BY TRAINED SERVICE PROVIDERS ONLY)

CONDITION	TROUBLESHOOTING
Head Pressure Too High	Check that the condensing coil is not dirty or covered.
	Check that condensing fans are working.
	Check that refrigerant is not overcharged.
	Perform sub-cooling check and verify that no contaminants are in system.
	Check that liquid line filter dryer is not plugged.
	Check that close-offs are intact (around condensing coil) and that air is not recirculating.
	Check that store ambient temperature isn't above maximum allowed. See OVERVIEW / TYPE / COMPLIANCE / WARNINGS / PRECAUTIONS / WIRING / PLUGS section in this manual.
Head Pressure Too Low	Check if sight glass is flashing or showing low charge.
	Check that suction pressure isn't too low.
	Check that compressor reed valves aren't bad. Look for high suction/low head pressure. Perform pump-down.

TROUBLESHOOTING - EVAPORATOR SYSTEM (BY TRAINED SERVICE PROVIDERS ONLY)

CONDITION	TROUBLESHOOTING
Low Suction Pressure	Check if sight glass is flashing or showing low charge.
	Check that expansion valve (TXV) isn't restricted. Check element charge.
	Check that liquid line or filter isn't restricted. Check that refrigeration lines and/or hoses are not kinked on either high or low sides.
	Check that evaporator fan motors are working.
	Check that superheat is between 6 °F to 8 °F.
	Check that there is no air recirculation around evaporator coil.
	Check that evaporator coil is not iced up.
High Suction Pressure	Check for refrigerant overcharge.
	Check that compressor reed valves aren't bad. Look for high suction/low head pressure. Perform pump down.
	Check that the "cooling load" isn't high. Product must be pre-chilled before placing in refrigerated section of case.
	Check that case is at least <u>15-feet</u> from exterior doors, overhead HVAC vents or any air curtain disruption.
	Check that unit is not exposed to direct sunlight via windows or any other heat source (ovens, fryers, etc.).
	Check that superheat adjustment isn't low.
	Check TXV bulb installation <ul style="list-style-type: none"> a. Poor thermal contact. b. Warm location.

Serial Label Location & Information Listed / Technical Information & Service



- Serial labels are located near the electrical access on your case.
- Serial labels contain electrical, temperature & refrigeration information, as well as regulatory standards to which the case conforms.
- For additional technical information and service, see the *TECHNICAL SERVICE* page in this manual for instructions on contacting Structural Concepts' Technical Service Department.
- See images below for samples of both refrigerated and non-refrigerated serial labels.



888 E. Porter Rd · Muskegon, MI 49441

ENCORE[®] MODEL HV74RSS SCROLL
SERIES SERIAL NO.

FOR PARTS AND SERVICE
CALL 1-800-433-9489

3048256

CONFORMS TO UL STD 471
CONFORMS TO NSF STD 7
CERTIFIED TO CAN/CSA
STD C22.2 NO 120

ELECTRICAL RATING	120/1/60 24A
REFRIGERANT	R404A AMOUNT ?? OZ
DESIGN PRESSURE	HIGH 450 LOW 200
MINIMUM CIRCUIT	30A
MAXIMUM OVERCURRENT	30A

SAMPLE ONLY

Super Heat Temp	8-10°F
BTUH Requirements	9,738 BTUH @ 20° F SST
Defrost	6 defrosts per day, 45° F termination, 45 min. failsafe

SAMPLE ONLY

SAMPLE ONLY

----- Sample Serial Label For Refrigerated Case -----



888 E. Porter Rd · Muskegon, MI 49441

Addenda[®] PC5682 txtRemote
txtSerialNumber

120 VOLTS 60 HZ SINGLE PHASE 1.84AMP

FOR PARTS OR SERVICE CALL
STRUCTURAL CONCEPTS
AT
1-800-433-9489



3048256

CONFORMS TO UL STD 65
CERTIFIED TO CAN/CSA
STD C22.2 NO 120

SAMPLE ONLY

----- Sample Serial Label For Non-Refrigerated Case -----

CAREL

ir33 platform

Integrated Electronic
Microprocessor Controller



Programming The Instrument

To Modify Defrost, Differential and Other Parameters



Set

1. Press & hold “Prg” & “SET” keys together for at least five (5) seconds; display will flash “0,” representing password prompt.



2. Press ▲ until password “22” is reached.



3. Press “SET” key to confirm password.



def

4. Press ▲ or ▼ to reach a category to be modified.



5. Press “SET” to modify selected parameter.



def

6. Increase or decrease the value using the ▲ or ▼ button respectively.



7. Press the “SET” key to temporarily save the new value and return to the parameter display.



8. Press & hold the “Prg” key for 5 full seconds to save changes. This will also mute the audible alarm (buzzer) and deactivate the alarm relay.

Warning! Save Your Parameter Settings!

1. To store the new parameter values, PRESS and HOLD the “Prg” key for at least 5 seconds.
2. All modifications made to parameters will be lost if you do NOT press a button within 60 seconds. Should this “timeout” occur, normal operational settings (prior to modifications being made) will resume.
3. If the instrument is switched off before pressing the “Prg” key, all modifications to parameters will be lost.

To Activate Manual Defrost



Press and hold “def” key for at least 5 seconds.

To Activate / Deactivate Auxiliary Output



Press and hold the “aux” key for 1 second.

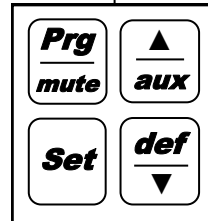

How To Change Reading From Fahrenheit (°F) To Celsius (°C)



Set

1. Press and hold “Prg” and “SET” keys together for at least 5 seconds; display will show “0” (password prompt).



2. Press ▲ until password “22” is reached.



3. Confirm by pressing “SET” key.



def

4. Press ▲ or ▼ until reaching the parameter “/ 5.”



5. Press “SET” to modify this selected parameter.



def

6. Press ▲ or ▼ to change value to desired setting: “0” for Celsius (°C) or “1” for Fahrenheit (°F).



7. Press “SET” key to temporarily save the new value and return to the display of the parameter.



Set

8. Press & hold “Prg” key for 5 full seconds to save changes. **Note! All values will automatically convert to new scale. No conversion is required.**

To Reset Any Alarms With Manual Reset



aux

Press and hold the “Prg” and “aux” key for at least 1 second.

This data derived from Carel® Controller Material:
ir33 +030220441 - rel. 2.0 - 01.05.2006.
Structural Concepts Document - Revision B Date: 4/25/2019

CAREL

ir33 platform
**Integrated Electronic
 Microprocessor Controller**

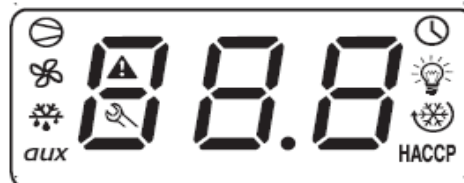

User Interface - Display

ICON	FUNCTION	DESCRIPTION	ON	Normal operation OFF	BLINK	Start up
	COMPRESSOR	ON when the compressor starts. Flashes when the activation of the compressor is delayed by safety times.	Compressor on	Compressor off	awaiting activation	
	FAN	ON when the fan starts. Flashes when the activation of the fan is prevented due to external disabling or procedures in progress.	Fan on	Fan off	awaiting activation	
	DEFROST	ON when the defrost is activated. Flashes when the activation of the defrost is prevented due to external disabling or procedures in progress.	Defrost in progress	Defrost not in progress	awaiting activation	
	AUX	Flashes if the anti-sweat heater function is active, ON when the auxiliary output (1 and/or 2) selected as AUX (or LIGHT in firmware version 3.6) is activated.	AUX auxiliary output active (version 3.6 light auxiliary output active)	AUX auxiliary output not active	Anti-sweat heater function active	
	ALARM	ON following pre-activation of the delayed external digital input alarm. Flashes in the event of alarms during normal operation (e.g. high/low temperature) or in the event of alarms from an immediate or delayed external digital input.	Delayed external alarm (before the time 'A7' elapses)	No alarm present	Alarms in norm. operation (e.g. High/low temperature) or immediate or delayed alarm from external digital input	
	CLOCK	ON if at least one timed defrost has been set. At start-up, comes ON for a few seconds to indicate that the Real Time Clock is fitted.	If at least 1 timed defrost event has been set	No timed defrost event set	Alarm clock	ON if real-time clock present
	LIGHT	Flashes if the anti-sweat heater function is active, ON when the auxiliary output (1 and/or 2) selected as LIGHT is activated (in firmware version 3.6 it does not flash in anti-sweat heater mode and comes on when the dead band output is active).	Light auxiliary output on (version 3.6 dead band auxiliary output active)	Light auxiliary output off	Anti-sweat heater function active (version 3.6 does not flash in anti-sweat heater mode)	
	SERVICE	Flashes in the event of malfunctions, for example E2PROM errors or probe faults.		No malfunction	Malfunction (e.g. E2PROM error or probe fault). Contact service	
	CONTINUOUS CYCLE	ON when the CONTINUOUS CYCLE function is activated. Flashes if the activation of the function is prevented due to external disabling or procedures in progress (E.g.: minimum compressor OFF time).	CONTINUOUS CYCLE operation activated	CONTINUOUS CYCLE function not activated	CONTINUOUS CYCLE operation requested	

Summary Table of Alarm and Signals: Display, Buzzer and Relay

Code	Icon on the display	Alarm relay	Buzzer	Reset	Description
rE	flashing	on	on	automatic	virtual control probe fault
E0	flashing	off	off	automatic	room probe S1 fault
E1	flashing	off	off	automatic	defrost probe S2 fault
E2	flashing	off	off	automatic	probe S3 fault
E3	flashing	off	off	automatic	probe S4 fault
E4	flashing	off	off	automatic	probe S5 fault
	No	off	off	automatic	probe not enabled
LO	flashing	on	on	automatic	low temperature alarm
HI	flashing	on	on	automatic	high temperature alarm
AFr	flashing	on	on	manual	antifreeze alarm
IA	flashing	on	on	automatic	immediate alarm from external contact
dA	flashing	on	on	automatic	delayed alarm from external contact
dEF	on	off	off	automatic	defrost running
Ed1	No	off	off	automatic/manual	defrost on evaporator 1 ended by timeout
Ed2	No	off	off	automatic/manual	defrost on evaporator 2 ended by timeout
Pd	flashing	on	on	automatic/manual	maximum pump down time alarm
LP	flashing	on	on	automatic/manual	low pressure alarm
AtS	flashing	on	on	automatic/manual	autostart in pump down
cht	No	off	off	automatic/manual	high condenser temperature pre-alarm
CHT	flashing	on	on	manual	high condenser temperature alarm
dor	flashing	on	on	automatic	door open too long alarm
EE	flashing	off	off	automatic	E2prom error, unit parameters
EF	flashing	off	off	automatic	E2prom error, operating parameters
ccb	Signal				start continuous cycle request
ccE	Signal				end continuous cycle request
dFb	Signal				start defrost call
dFE	Signal				end defrost call
On	Signal				switch ON
off	Signal				switch OFF
rES	Signal				reset alarms w/manual reset / reset HACCP alarms / reset temp. monitoring

This data derived from Carel® Controller Material:
 ir33 +030220441 - rel. 2.0 - 01.05.2006.
 Structural Concepts Document - Revision B Date: 4/25/2019

CAREL

ir33 platform

Integrated Electronic
Microprocessor Controller



Summary Table of Operating Parameters

CODE	PARAMETER	UOM*	TYPE	MINIMUM	MAXIMUM	DEFAULT
/5	Select Celsius (°C) or Fahrenheit (°F)	flag	C	0	1	For Case Specific Defaults See Serial Label Located Near Electrical Access On Your Case. For Additional Technical Information Call Structural Concepts Technical Service Dept. at 1(800) 433.9490 Ext. 1
/c1	Calibration of probe 1	°C/°F	C	-20	20	
/c2	Calibration of probe 2	°C/°F	C	-20	20	
St	Temperature set point	°C/°F	F	r2	r1	
rd	Control delta	°C/°F	F	20	0.1	
dl	Interval between defrosts	hours	F	0	250	
dt1	End defrost temperature, evaporator	°C/°F	F	-50	200	
dP1	Maximum defrost duration, evaporator	min	F	1	250	
d6	Display on hold during defrost	-	C	0	2	
dd	Dripping time after defrost	min	F	0	15	
d/1	Display of defrost probe 1	°C/°F	F	-	-	

* Unit Of Measure

This data derived from Carel® Controller Material:
ir33 +030220441 - rel. 2.0 - 01.05.2006.
Structural Concepts Document - Revision B Date: 4/25/2019

Dixell

Installing and operating instructions

EMERSON

**CONTROLLERS FOR MULTIPLEXED CABINETS
XM670K - XM679K
- MANUAL FOR THE SW REL 3.4 -**

1. GENERAL WARNING

1.1 PLEASE READ BEFORE USING THIS MANUAL

- This manual is part of the product and should be kept near the instrument for easy and quick reference.
- The instrument shall not be used for purposes different from those described hereunder. It cannot be used as a safety device.
- Check the application limits before proceeding.
- Dixell Srl reserves the right to change the composition of its products, even without notice, ensuring the same and unchanged functionality.

1.2 SAFETY PRECAUTIONS

- Check the supply voltage is correct before connecting the instrument.
- Do not expose to water or moisture: use the controller only within the operating limits avoiding sudden temperature changes with high atmospheric humidity to prevent formation of condensation
- Warning: disconnect all electrical connections before any kind of maintenance.
- Fit the probe where it is not accessible by the End User. The instrument must not be opened.
- In case of failure or faulty operation send the instrument back to the distributor or to "Dixell S.r.l." (see address) with a detailed description of the fault.
- Consider the maximum current which can be applied to each relay (see Technical Data).
- Ensure that the wires for probes, loads and the power supply are separated and far enough from each other, without crossing or intertwining.
- In case of applications in industrial environments, the use of mains filters (our mod. FT1) in parallel with inductive loads could be useful.

2. BEFORE PROCEEDING

2.1 CHECK THE SW REL. OF THE XM679K

1. Look at the SW rel. of XM679K printed on the label of the controller.

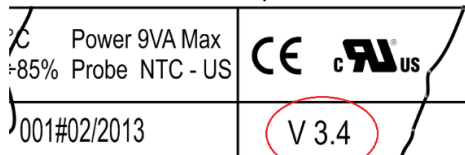

2. If the SW release is 3.4 proceed; otherwise, contact Dixell to secure correct manual.

3.0 GENERAL DESCRIPTION

The **XM670K/XM679K** are high level microprocessor-based controllers for multiplexed cabinets suitable for applications on medium or low temperature. It can be inserted in a LAN of up to 8 different sections which can operate (depending on the programming) as standalone controllers or following the commands coming from other sections. The **XM670K/XM679K** have 6 relay outputs to control the solenoid valve, defrost (which can be either electrical or hot gas), evaporator fans, lights, an auxiliary output and an alarm output with one output to drive **pulsed electronic expansion valves (only XM679K)**. The devices are also provided with four probe inputs: 1) temperature control 2) control of defrost end temperature of evaporator 3) display 4) for application with virtual probe or for inlet/outlet air temperature measurement. Model **XM679K** is provided with two other probes to be used for superheat measurement and regulation. Finally, the **XM670K/XM679K** are equipped with three digital inputs (free contact) fully configurable by parameters. Instruments are equipped with the HOTKEY connector that permits simple programming. Direct serial output **RS485 ModBUS-RTU** compatibility permits simple XWEB interfacing. **RTC** are available as options. The HOTKEY connector can be used to connect **X-REP** display (depending on the model).

3.01 KEYS & FUNCTIONS ON CONTROLLER FRONT PANEL

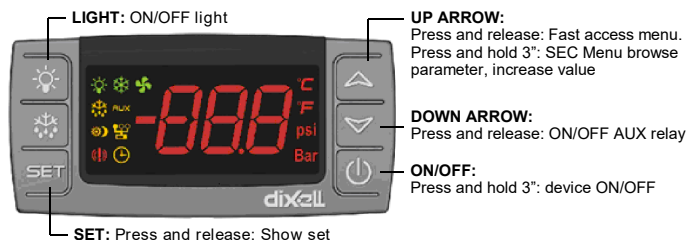







3.1 KEYS & FUNCTIONS ON CONTROLLER FRONT PANEL

Key	Function
SET	Press to display the target setpoint, to select a parameter in programming mode, or to confirm an operation. Pressing this key for 3 seconds while the minimum or maximum temperature is displayed will erase the temperature currently displayed.
▲	Press this key to browse the parameter codes in programming mode or increases the displayed value. Pressing this key for 3 seconds will give you access to the Section menu.
▼	Press this key to access the fast access menu, browse the parameter codes in programming mode, decrease the displayed value, or activate or deactivate an auxiliary output.
❄️	Starts a defrost when pressed for 3 seconds.
💡	Switches the room light ON and OFF.
⏻	Press for 3 seconds to switch the device ON and OFF.
°C	Measurement unit

Key	Function
°F	Measurement unit
BAR	Measurement unit
PSI	Measurement unit
<p>Note: Units With These Temperature Controllers Have Been Hot-Keyed At Factory For General Operation.</p>	
Key Combinations	
▼ + ▲	Locks/Unlocks the keyboard
SET + ▼	Switches mode to programming mode
SET + ▲	Exits the programming mode

3.2 USE OF LEDs

Note: Units With These Temperature Controllers Have Been Hot-Keyed At Factory For General Operation.

LED	Mode	Function
	ON	Compressor and valve regulation enabled. To see the valve opening percentage, enter the fast access menu.
	Flashing	Anti-short cycle delay enabled
	ON	Defrost enabled
	Flashing	Drip time in progress
	ON	An alarm is occurring
	ON	Energy saving enabled
	ON	Fans enabled (fans are running)
	Flashing	Door opened or delay after defrost
AUX	ON	Auxiliary relay ON
°C/°F/Bar/PSI	ON	Measurement unit
	Flashing	Programming phase
	ON	The controller is working in ALL mode
	Flashing	The controller is working in remote virtual display mode
	Flashing	During the CLOCK modification (if clock is present)

3.3 HOW TO ENTER THE FAST ACCESS MENU

1. Press and release the UP button.
2. The First Label will be displayed. Press the UP or DOWN button to navigate the menu.

3.4 HOW TO SEE MAX AND MIN TEMPERATURE RECORDED

1. Press and release the UP button.
2. The First Label will be displayed. Press the UP or DOWN button to navigate the menu. Search the **L^ot** label and press SET to see minimum temperature; search the **H^ot** label and press SET to see maximum temperature.

3.5 HOW TO SEE AND MODIFY THE SETPOINT

1. Press the SET button for 3 seconds to show the setpoint value.
2. The measurement unit starts blinking.
3. To change the setpoint value, press the UP or DOWN button for 10 seconds.
4. To store the new setpoint value, press the SET key again or wait 10 seconds.

3.6 HOW TO START A MANUAL DEFROST



Press the **DEF** key for more than 3 seconds to start a manual defrost.

3.7 HOW TO ENTER THE PARAMETERS LIST PR1

To enter the parameter list in **Pr1** (user accessible parameters):

1. Enter the programming mode by pressing the SET and DOWN buttons for a few seconds (wait for the measurement unit to start blinking).
2. The controller will show the first parameter present in **Pr1**.

3.8 HOW TO ENTER THE PARAMETERS LIST PR2

To access the parameter list in **Pr2**:

1. Enter the **Pr1** level. Follow the steps in **Section 3.7., How to Enter the Parameters List PR1.**
2. Select **Pr2** parameter and press the SET key.
3. The **PAS** flashing message will display, followed shortly by “0 --” with a flashing zero.
4. Use the UP or DOWN button to input the security code in the flashing digit. Confirm the security code by pressing SET. The security code is **321**.
5. If the security code is correct, the access to **Pr2** is enabled by pressing SET on the last digit.

Another way to enter the programming mode is by pressing the SET and DOWN buttons for 30 seconds immediately after switching the controller ON.

NOTE: Each parameter in Pr2 can be removed or put into Pr1 (user level) by pressing SET + DOWN buttons. When a parameter is present in Pr1, the Alarm LED will be display.

Dixell

Installing and operating instructions

EMERSON

3.9 HOW TO ASSIGN A MODBUS ADDRESS

1. To enter the programming mode, press and hold the SET and DOWN buttons together until the temperature measurements start blinking.
2. Scroll through the parameters using the UP or DOWN button until **Adr** is displayed.
3. Press and hold SET to select **Adr**.
4. Use the arrow keys to choose the address number of the device.
5. Press and hold SET again to select the desired number and save.
6. To exit, press the SET and UP arrow keys together.

3.10 HOW TO CHANGE THE PARAMETER VALUE

1. Enter the programming mode.
2. Select the required parameter using the UP or DOWN button.
3. Press the SET key to display the parameter value (measurement unit starts blinking).
4. Use the UP or DOWN button to change the value.
5. Press SET to store the new value and move to the next parameter.
6. To exit, press SET + UP keys or wait 15 seconds without pressing a key.

3.11 ON/OFF FUNCTION



By pressing the ON/OFF key, the controller shows OFF. During the OFF status, all the relays are switched OFF and the regulations are stopped; if a monitoring system is connected, it does not record the controller data and alarms.



NOTE: During the OFF status, the Light and AUX buttons are active.

4. FAST ACCESS MENU

Note: Units With These Temperature Controllers Have Been Hot-Keyed At Factory For General Operation.

FAST ACCESS MENU		
HM	Fast Access Menu to Clock Settings	(If present)
An	Fast Access to Analog Output Reading	(If present)
SH	Superheat	Shows the actual superheat value (Only XM679)
oPP	Valve opening percentage	Shows the actual opening percentage of the valve (Only XM679)
dP1	Probe 1 value displaying	Shows the temperature measured by probe 1
dP2	Probe 2 value displaying	Shows the temperature measured by probe 2
dP3	Probe 3 value displaying	Shows the temperature measured by probe 3
dP4	Probe 4 value displaying	Shows the temperature measured by probe 4
dP5	Probe 5 value displaying	Shows the temperature measured by probe 5
dP6	Probe 6 value displaying	Shows the temperature measured by probe 6
dPP	Pressure probe value	Shows the value of pressure measured by pressure transducer (Only XM679)
rPP	Remote pressure probe value	Shows the value of pressure received by remote pressure probe connected to other XM600 device (Only XM679)
L^ot	Minimum measured temperature	Shows the minimum temperature read by the regulation probe
H^ot	Maximum measured temperature	Shows the maximum temperature read by the regulation probe
dPr	Virtual regulation probe value	Shows the value measured by the virtual regulation probe
dPd	Virtual defrost probe value	Shows the value measured by the virtual defrost probe
dPF	Virtual fans probe value	Shows the value measured by virtual fan probe
rSE	Real setpoint	Shows the setpoint used during the energy saving cycle or during the continuous cycle

Dixell

Installing and operating instructions

EMERSON

5.0 SECTIONS MENU

This menu allows the user to access to a particular feature of the XM series related to the LAN (Local Area Network) of controllers. Depending on the programming of this menu, a single keyboard can control either the module of the local section of the LAN or ALL. The possibilities are: LOC: the keyboard controls and display the value, the status, and the alarms of the local section of the LAN; and ALL: the command given by the keyboard are effective on all the sections of the LAN.

1. Press the UP key for more than 3 seconds.
2. The label corresponding to the section controlled by the keyboard will be displayed.
3. Using the UP or DOWN key, select the section you want to control.
4. Press the SET key to confirm and exit.

5.1 TO SET ENERGY SAVING TIMES

ILE	Energy Saving cycle start during workdays	(0 to 23 h 50 min) During the Energy Saving cycle, the setpoint is increased by the value in HES so that the operation setpoint is SET + HES.
dLE	Energy Saving cycle length during workdays	(0 to 24 h 00 min) Sets the duration of the Energy Saving cycle on workdays.
ISE	Energy Saving cycle start on holidays	(0 to 23h 50 min)
dSE	Energy Saving cycle length on holidays	(0 o 24h 00 min)
HES	Temperature increase during the Energy Saving cycle	(-30 to 30°C/ -54 to 54°F) Sets the increasing value of the setpoint during the Energy Saving cycle.

5.2 TO SET TIMED DEFROST PARAMETERS

Ld1 to Ld6	Workday defrost start	(0 to 23h 50 min) These parameters set the beginning of the eight programmable defrost cycles during workdays. For example, when Ld2=12.4, the second defrost starts at 12.40 during workdays.
Sd1 to Sd6	Holiday defrost start	(0 to 23h 50 min) These parameters set the beginning of the eight programmable defrost cycles during holidays. For example, when Sd2=3.4, the second defrost starts at 3.40 on holidays.



NOTE: To disable a defrost cycle, set it to nu (not used). For example, if Ld6=nu, the sixth defrost cycle is disabled.

6.0 ELECTRONIC EXPANSION VALVE MENU (MODEL XM679 ONLY)

1. Enter the programming mode by pressing the SET and DOWN buttons for a few seconds (measurement unit starts blinking).
2. Press the UP or DOWN key until the controller displays the EEU label.
3. Press SET. You are now in EEV function menu.

7.0 CONTROLLING LOADS / 7.1 SOLENOID VALVE

The regulation is performed based on the temperature measured by the thermostat probe (either physical or virtual) obtained by a weighted average between the two probes with a positive differential from the setpoint. If the temperature increases and reaches setpoint plus the differential, the solenoid valve is opened and then it is closed when the temperature reaches the setpoint value again.

Note: Units With These Temperature Controllers Have Been Hot-Keyed At Factory For General Operation.

In case of fault in the thermostat probe, the opening and closing time of the solenoid valve is configured by **Con** and **CoF** parameters.

19. USE OF THE PROGRAMMING "HOT KEY"

The XM units can UPLOAD or DOWNLOAD the parameter list from its own E2 internal memory to the "Hot Key" and vice-versa through a TTL connector.

19.1 DOWNLOAD (FROM THE "HOT KEY" TO THE INSTRUMENT)

1. Turn OFF the instrument by means of the ON/OFF key, insert the "Hot Key" and then turn the unit ON.
2. Automatically the parameter list of the "Hot Key" is downloaded into the controller memory, the "doL" message is blinking. After 10 seconds the instrument will restart working with the new parameters. At the end of the data transfer phase the instrument displays the following messages: "end" for right programming. The instrument starts regularly with the new programming. "err" for failed programming. In this case turn the unit off and then on if you want to restart the download again or remove the "Hot key" to abort the operation.

19.2 UPLOAD (FROM THE INSTRUMENT TO THE "HOT KEY")

1. When the XM unit is ON, insert the "Hot key" and push ⇐ key; the "uPL" message appears.
 2. The UPLOAD begins; the "uPL" message is blinking.
 3. Remove the "Hot Key".
- At the end of the data transfer phase the instrument displays the following messages: "end" for right programming. "err" for failed programming. In this case push "SET" key if you want to restart the programming again or remove the not programmed "Hot key".

STRUCTURAL CONCEPTS TECHNICAL SERVICE CONTACT INFORMATION & LIMITED WARRANTY

TECH SERVICE/WARRANTY CONTACT INFO: 1 (800) 433-9490 / EXTENSION 1

DAYS/HOURS AVAILABLE:
MONDAY - FRIDAY (CLOSED HOLIDAYS)
8:00 a.m. TO 5:00 p.m. EST

YOU MUST HAVE THE FOLLOWING INFO AVAILABLE BEFORE CONTACTING STRUCTURAL CONCEPTS:

SERIAL NO. / MODEL NO. / STORE NO. / STORE
ADDRESS / DETAILS (PHOTOS, LEAK LOCATIONS,
DAMAGE, STORE'S AMBIENT CONDITIONS, ETC.)

LIMITED WARRANTY

Overview: All sales by Structural Concepts Corporation (hereafter referred to as "SCC") are subject to the following limited warranty. "Goods" refers to the product or products being sold by SCC.

Warranty Scope: Warranty is for equipment sold in the United States, Canada, Mexico and Puerto Rico. Equipment sold elsewhere may carry modified warranties.

Warranty; Remedies; Limitations: The limit of liability of SCC toward the exchange cost of the original compressor motor (and/or any other components) is one year parts and labor. If any Goods are found to be of faulty material or workmanship within one year of the original F.O.B. (free on board) unit shipment, SCC will, at its option (after inspection by an authorized representative), replace or pay the reasonable cost of replacement of the faulty Goods. If warranty claim is not made within this one year time period, SCC is not bound to warrant Goods. A motor-compressor (and/or any other components) replaced during the warranty shall not exceed manufacturer's current established wholesaler's exchange price. If replacement motor-compressor (and/or other components) is available via storage facility, parts truck, etc., SCC mandates that readily accessible replacement components be used toward repair of Goods; in such instances, SCC will replace such equipment (at its own expense) after confirmation of its use/placement on defective unit. SCC shall not be charged an additional fee, up-charge or expense for such replacement Goods. If SCC is unable to repair or replace the defective Goods, SCC shall issue a credit to the Purchaser for full or partial purchase price, as SCC shall determine. The replacement or payment in the manner described above shall be the sole and exclusive remedy to Purchaser for a breach of this warranty. If any Goods are defective or fail to conform to this warranty, SCC will furnish instructions for their disposition. No Goods shall be returned to SCC without its prior consent.

SCC's liability for any defect in the Goods shall not exceed the purchase price of the Goods. SCC SHALL HAVE NO LIABILITY TO PURCHASER FOR CONSEQUENTIAL DAMAGES OF ANY KIND WHATSOEVER, INCLUDING, BUT NOT LIMITED TO, PERSONAL INJURY, PROPERTY DAMAGE, LOST PROFITS, OR OTHER ECONOMIC INJURY DUE TO ANY DEFECT IN THE GOODS OR ANY BREACH OF SCC, SCC SHALL NOT BE LIABLE TO THE PURCHASER IN TORT FOR ANY NEGLIGENT DESIGN OR MANUFACTURE OF THE GOODS, OR FOR THE OMISSION OF ANY WARNING THEREFROM.

SCC shall have no obligation or liability under this warranty for claims arising from any other party's (including Purchaser's) negligence or misuse of the Goods or environmental conditions. This warranty does not apply to any claim or damage arising from or caused by improper storage, handling, installation, maintenance, or from fire, flood, accidents, structural defects, building settlement or movement, acts of God, or other causes beyond SCC's control.

Except as expressly stated herein, SCC makes no warranty, express, implied, statutory or otherwise as to any parts or goods not manufactured by SCC. SCC shall warrant such parts or Goods only (I) against such defects, (II) for such periods of time, and (III) with such remedies, as are expressly warranted by the manufacturer of such parts of Goods. Notwithstanding the foregoing, any warranty with respect to such parts of Goods and any remedies available as a result of a breach thereof shall be subject to all of the procedures, limitations, and exclusions set forth herein.

THE WARRANTIES HEREIN ARE IN LIEU OF ALL WARRANTIES, EXPRESS, IMPLIED, STATUTORY, OR OTHERWISE. IN PARTICULAR, SCC MAKES NO WARRANTY OF MERCHANTABILITY OR FITNESS FOR A PARTICULAR PURPOSE.

No representative, agent or dealer of SCC has authority to modify, expand, or extend this Warranty, to waive any of the limitations or exclusions, or to make any different or additional warranties with respect to Goods.

Period of Limitations: No claim, suit or other proceeding may be brought by Purchaser for any breach of the foregoing warranty or this Agreement by SCC or in any way arising out of this Agreement or relating to the Goods after one year from the date of the breach. In the interpretation of this limitation on action for a breach by SCC, it is expressly agreed that there are no warranties of future performance of the goods that would extend that period of limitation herein contained for bringing an action.

Indemnifications: Purchaser agrees to indemnify, hold harmless, and defend SCC if so requested, from any and all liabilities, as defined herein, suffered, or incurred by SCC as a result of, or in connection with, any act, omission, or use of the Goods by Purchaser, its employees or customers, or any breach of this Agreement by Purchaser. Liabilities shall include all costs, claims, damages, judgments, and expenses (including reasonable attorney fees and costs).

Remedies of SCC: SCC's rights and remedies shall be cumulative and may be exercised from time to time. In a proceeding or action relating to the breach of this Agreement by Purchaser, Purchaser shall reimburse SCC for reasonable costs and attorney's fees incurred by SCC. No waiver by SCC of any breach of Purchaser shall be effective unless in writing nor operate as a waiver of any other breach of the same term thereafter. SCC shall not lose any right because it has not exercised it in the past.

Applicable Law. This Agreement is made in Michigan; it is governed by and interpreted according to Michigan law. Any lawsuit arising out of this Agreement or the Goods may be handled by a federal or state court whose district includes Muskegon County, Michigan, and Purchaser consents that such court shall have personal jurisdiction over Purchaser.

LED Lighting Components Within Lighting System: Supermarket: 5-year LED warranty from date of shipment. **Foodservice:** 2-year LED warranty from date of shipment. After one year, warranty does not include labor or other costs incurred for diagnosing, repairing, removing, installing, shipping, servicing, or handling of either defective part or replacement parts. Remedy of repair or provision of a replacement part without charge shall be the exclusive remedy for any warranty claim. The replacement LED and/or power supply assumes the unused portion of warranty remaining on unit(s). A 90-day warranty will apply for any LED sold as a service part. Warranty claim must include serial and model number of unit as well as date code on defective LED lighting component(s). Manufacturer may request return of defective part(s) at customer's expense to initiate claim.

Glass Material: Glass (UV-bonded glass, glass sneeze guards, glass enclosures, glass held in place via posts, etc.) is only warranted to FIRST POINT OF DELIVERY.

Miscellaneous: If any provision of this Agreement is found to be invalid or unenforceable under any law, the provision shall be ineffective to that extent and for the duration of the illegality, but the remaining provisions shall be unaffected. Purchaser shall not assign any of its rights nor delegate any of these obligations under this Agreement without prior written consent of SCC. This Agreement shall be binding upon and inure to the benefit of SCC and Purchaser and each of their legal representatives, successors and assignees. SCC warrants its products to be free of defects in materials and workmanship under normal use and service for a period of one (1) year from the date of delivery.

This warranty is extended only to the original purchaser for use of the Goods. It does not cover normal wear parts such as plastic tongs, tong holders, tong cables, bag holders, or acrylic dividers.

General Conditions: All service labor and/or parts charges are subject to approval by SCC. Contact Customer Service Dept. in writing, by phone, fax or email.

All claims must contain the following information: (1) model & serial code number of equipment; (2) the date and place of installation; (3) the name and address of the agency which performed the installation; (4) the date of the equipment failure; and (5) a complete description of the equipment failure and all circumstances relating to that failure.

Once the claim has been determined to be a true warranty claim by SCC's Customer Service Department, the following procedure will be taken: (1) replacement parts will be sent at no charge from SCC on a freight prepaid basis; (2) reimbursement for service labor will be paid if the following conditions have been met - (a) prior approval of service agency was awarded from the Customer Service Department; and (b) an itemized statement of all labor charges incurred is received by the Customer Service Department. The cost of the service labor reimbursement will be based on straight time rates and reasonable time for the repair of the defect.

If problems occur with any compressor, notify SCC's Customer Service Department immediately. Any attempt to repair or alter the unit without prior consent from the Customer Service Department will render any warranty claim null and void. This warranty and protection plan does not apply to any condensing unit or any part thereof which has been subject to accident, negligence, misuse, or abuse, or which has not been operated in accordance with the manufacturer's recommendations or if the serial number of the unit has been altered, defaced, or removed.

One Year Limit of Liability: After SCC's one-year parts and labor warranty on the original F.O.B. (free on board) unit has expired, SCC is not liable for either the equipment or labor costs of repairing or replacing the motor compressor, nor any other components that were included in the original F.O.B. (free on board) unit.