



**PFA & PFC
VENTLESS COUNTERTOP DEEP FRYERS
REPLACEMENT PARTS LIST**

EFFECTIVE OCTOBER 29, 2020

Superseding All Previous Parts Lists.

The Company reserves the right to make substitution in the event that items specified are not available.

ERRORS: Descriptive and/or typographic errors are subject to correction.

PERFECT FRY COMPANY

42 Allen Martin Drive, Essex Junction, Vermont 05452 USA Telephone: (802) 658-6600 Fax: (802) 860-3732
www.perfectfry.com

P/N 83723 Rev D (10/20)

WARNING

DO NOT store or use gasoline or other flammable vapors and liquids in the vicinity of this or any other appliance.

WARNING

Improper installation, alteration, service or maintenance can cause property damage, injury or death. Read the installation, operating and maintenance instructions thoroughly before installing or servicing this appliance.

WARNING

Installation, maintenance and repairs should be performed by a Perfect Fry Authorized Service and Parts (ASAP) company technician or other qualified personnel. Installation, maintenance or repairs by an unauthorized and unqualified personnel will void the warranty.

WARNING

Installation and all connections must be made according to national and local regulations and codes in force.

WARNING

A country approved all pole circuit breaker with a minimum open contact gap of 3mm must be used for proper installation. (CE countries)

WARNING

During the warranty period if a customer elects to use a non-original part or modifies an original part purchased from Perfect Fry and/or its Authorized Service and Parts (ASAP) companies, this warranty will be void. In addition, Perfect Fry and its affiliates will not be liable for any claims, damages or expenses incurred by the customer which arises directly or indirectly, in whole or in part, due to the installation of any modified part and/or received from an unauthorized service center.

WARNING

This appliance, when installed, must be electrically grounded in accordance with local codes, or in the absence of local codes, with the National Electrical Code, ANSI/NFPA 70, or the Canadian Electrical Code, CSA C22.2, as applicable.

WARNING

Adequate means must be provided to LIMIT the movement of this appliance without depending on the electrical cord connection. Single appliances equipped with legs must be stabilized by installing anchor straps. All appliances equipped with casters must be stabilized by installing restraining chains.

WARNING

This appliance is intended for professional use only and should be operated by fully trained and qualified personnel.

WARNING

If the supplied power cord is damaged, it must be replaced by a Perfect Fry Authorized Service and Parts (ASAP) company technician, or a similarly qualified person in order to avoid a hazard.

WARNING

The power supply must be disconnected before servicing, maintaining or cleaning this appliance.

WARNING

The appliance is NOT jet stream approved. DO NOT clean the appliance with a water jet.

WARNING

DO NOT attempt to move this appliance or transfer hot liquids from one container to another when the unit is at operating temperature or filled with hot liquids. Serious personal injury could result if skin comes in contact with the hot surfaces or liquids.

WARNING

DO NOT sit or stand on this appliance. Serious injury could result from slipping, falling or contact with hot surfaces or liquids.

WARNING

NEVER use the appliance as a step for cleaning or accessing the ventilation hood. Serious injury could result from slips, trips or from contacting hot surfaces or liquids.

WARNING

DO NOT use the appliance unless it is properly secured to a table, stand or freezer / refrigerated base suited to handle the weight of the entire appliance.

WARNING

DO NOT operate appliance unless all panels and access covers are attached correctly.

WARNING

It is recommended that this appliance be inspected by a qualified service technician for proper performance and operation on a yearly basis.

TABLE OF CONTENTS

PFA MODEL	4
PFC MODEL	6
PERFECT FRY FILTER AREA	8
PFA OIL VAT ASSEMBLY	10
PFC OIL VAT ASSEMBLY.....	11
PFA DOOR/DRAWER AREA	12
PFC DOOR	13
PERFECT FRY HEATER ASSEMBLIES.....	14
PFA 3 PHASE	15
EBOX.....	16
FIRE SYSTEM	18

IMPORTANT FOR FUTURE REFERENCE

Please complete this information and retain this manual for the life of the equipment:

Model # _____

Serial # _____

Date Purchased _____

PFA MODEL

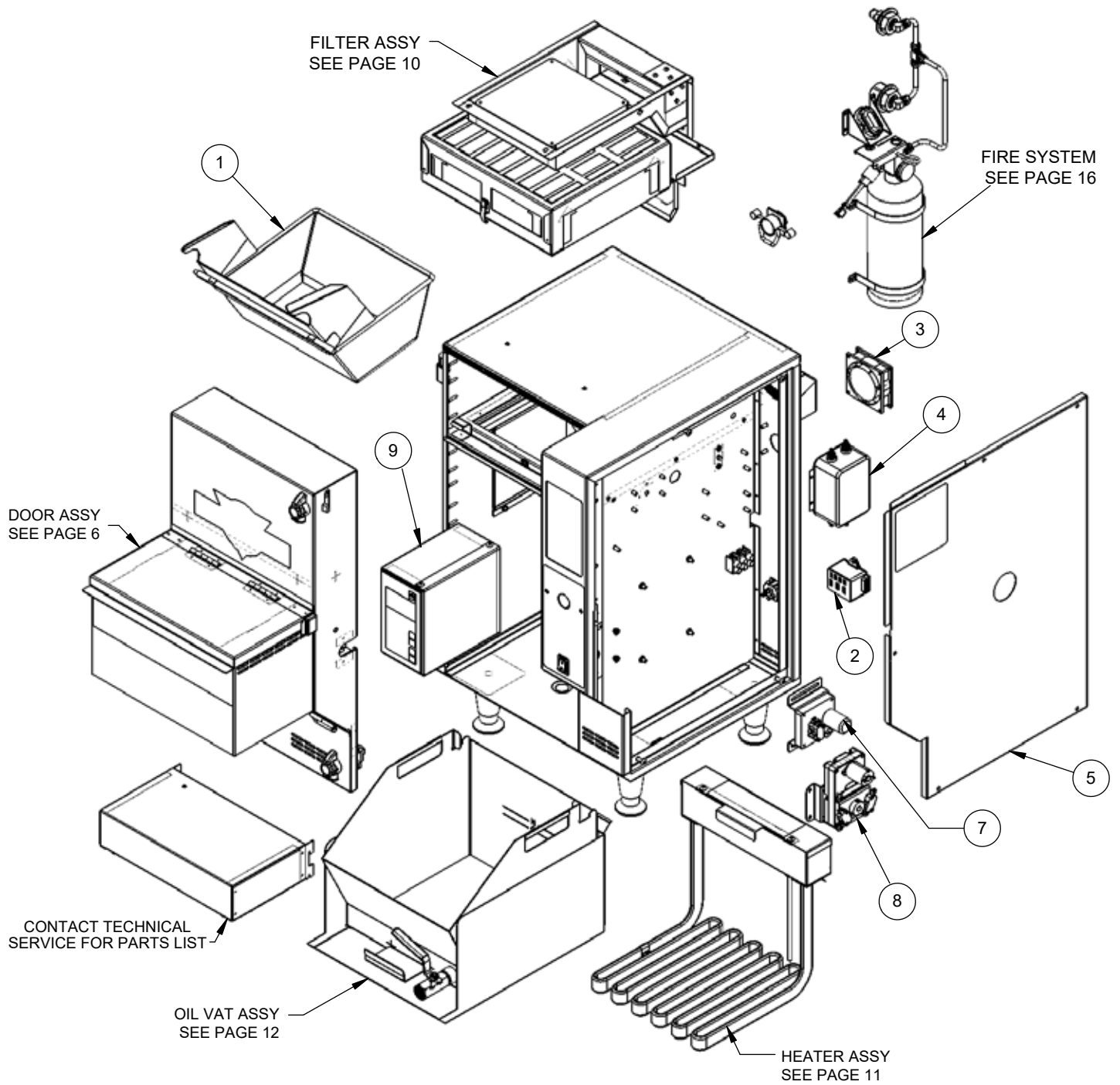

PFA MODEL

Item	Old P/N	New P/N	Description	QTY
1	3BA001	83258	ASSEMBLY, BASKET PFA	1
2	3CT765-C	83706	KIT, ASSEMBLYFEMALE CONNECTOR	1
3	2DT952	83423	KIT, CONTROL FAN	1
4	6WT903	83303	FILTER, EMI 30A	1
5	-	83780	CABINET, COVER SIDE ASSEMBLY PFA	1
7	2HA001-C	83237	DRAWER MOTOR ASSEMBLY	1
8	2HA002-C	83242	BASKET MOTOR ASSEMBLY	1
9	2WS802-C	83677	E BOX SERVICE KIT 1 PH (see EBOX pages for detailed breakdown)	-
NS	2DT002-CL	83636	KIT, FIRE ALARM WITH INSTRUCTIONS	1
NS	2DT965	83671	KIT, GASKET FRONT PFA (FOAM GASKET)	-
NS	2DT953-C	83425	KIT, FLAT MAGNETIC SWITCH	-
NS	2DT954	83424	KIT, ROUND MAGNETIC SWITCH	-
NS	6HT646	83209	SWITCH, AIRFLOW	1
NS	6CT100	83214	FEMALE PLUG COVER	-
NS	6FR021	83216	MOLDED SILICONE DOOR GASKET	-
NS	6CT720	83228	BUSHING, STRAIN RELIEF	-
NS	2HA002	83242	ASM, MOTOR MODULE BASKET PFA	-
NS	6HT739	83265	DRAIN HOSE, OIL VAT	-
NS	6HA007	83271	HINGE, LIFT OFF	-
NS	6HA023	83272	GASKET, MOTOR PFA	-
NS	4CA004	83296	HARNESS PFA EBOX TO MOTORS AND DOOR SWITCHES	-
NS	B6806501	83361	HARNESS, REM BUZZER CTRL	-
NS	6CA006	83447	CORD, HL, FRONT	-
NS	3CT765	83457	ELEMENT FEMALE PLUG AND HARNESS	-
NS	6HA004	83487	LEG, 4", PFA, FLANGED	-
NS	6HM013	83554	ROCKER SWITCH, HEAT LAMP	-
NS	S2028501	S0713	SILICONE 3OZ RTV	-
NS	2DT962	83669	ELEMENT FEMALE CONNECTOR HOUSING	-
NS	6HT790	83670	INSTANT ADHESIVE 3M CA40	-
NS	2DT970	83696	KIT ACCESS PANEL RETAINER NUT	-
NS	2DT958-C	83699	KIT FEMALE CONNECTOR	-
NS	6TT001	83702	MINI MOLEX PIN REMOVAL TOOL	-
NS	2TT001-CL	83703	KIT MOLDED GASKET RETROFIT, FOR UNITS MADE BEFORE 5/2016	-
NS	2TT002-CL	83704	KIT 6X MOLDED GASKET RETROFIT, FOR UNITS MADE BEFORE 5/2016	-
NS	2SK001-C	83721	ASM DRAWER AND LID W/DECALS	-
NS	2DT950-C	83722	KIT PFA FRONT PANEL SERVICE	-
NS	-	83382	HARNESS, EMI TO EBOX	-
NS	4CT686	83293	HARNESS, CTRL 1	-

PFC MODEL

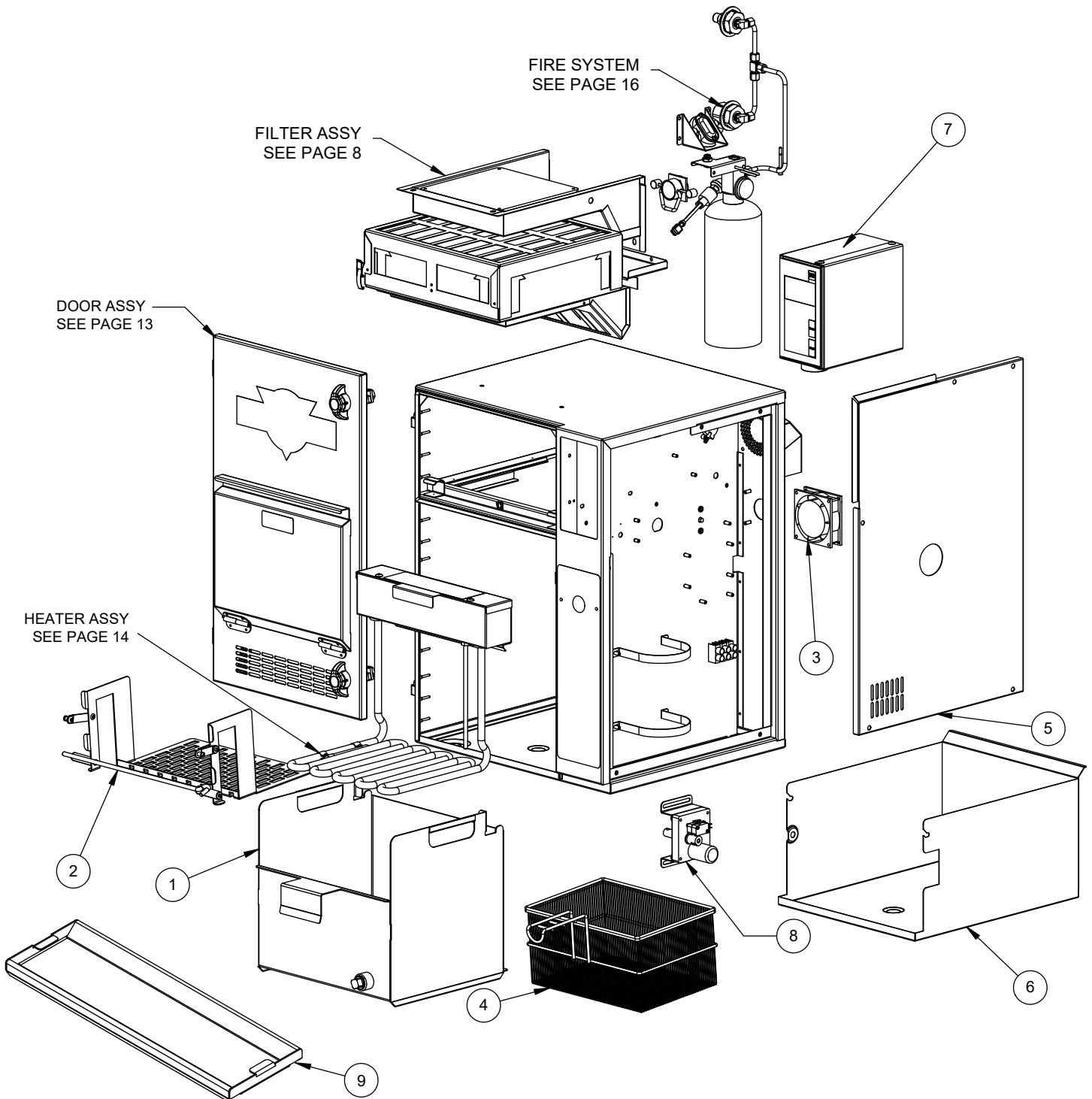

PFC MODEL

Item	Old P/N	New P/N	Description	QTY
1	2DT005-C	83273	ASSEMBLY, VAT PFC	1
2	3HT740-C	83193	ASSEMBLY, BASKET LIFT PFC	1
3	2DT952	83423	KIT, CONTROL FAN	1
4	6HT905	83281	BASKET, EXTRA LARGE PFC	1
5	-	83781	CABINET, COVER SIDE ASSEMBLY PFC	1
6	6ST734-C	83198	TRAY, SPILL PFC	1
7	2WS802-C	83677	E BOX SERVICE KIT 1 PH (see EBOX pages for detailed breakdown)	-
8	2HT689	83231	MOTOR ASSEMBLY	-
NS	3CT765-C	83706	ASSEMBLY, FEMALE CONNECTOR	1
NS	6HT002	83649	KIT, COVER X-L BASKET	1
NS	2DT959	83697	KIT, GASKET FRONT PFC	-
NS	2DT969-C	83705	KIT, FEET RUBBER PFC / SFC	-
9	6ST105	83181	PFC DRIP TRAY	-
NS	6CT100	83214	FEMALE PLUG COVER	-
NS	6FR021	83216	MOLDED SILICONE DOOR GASKET	-
NS	6CT720	83228	BUSHING, STRAIN RELIEF	-
NS	6HT739	83265	DRAIN HOSE, OIL VAT	-
NS	4CT686	83293	HARNESSE E BOX TO FAN AND FILTER SWITCHES	-
NS	B6806501	83361	HARNESSE, REM BUZZER CTRL	-
NS	3CT765	83457	ELEMENT FEMALE PLUG AND HARNESSE	-
NS	A6653523	83556	FLTR, HOSE 36.00 PFC MCD	-
NS	S2028501	S0713	SILICONE 3OZ RTV	-
NS	2DT962	83669	KIT, LIFT AND TURN LATCH	-
NS	6HT790	83670	INSTANT ADHESIVE 3M CA40	-
NS	2DT970	83696	KIT ACCESS PANEL RETAINER NUT	-
NS	2DT958-C	83699	KIT FEMALE CONNECTOR	-
NS	6TT001	83702	MINI MOLEX PIN REMOVAL TOOL	-
NS	2TT001-CL	83703	KIT MOLDED GASKET RETROFIT, FOR UNITS MADE BEFORE 5/2016	-
NS	2TT002-CL	83704	KIT 6X MOLDED GASKET RETROFIT, FOR UNITS MADE BEFORE 5/2016	-
NS	-	83786	E BOX SERVICE KIT MCD J	-
NS	2DT953-C	83425	KIT, FLAT MAGNETIC SWITCH	-
NS	2DT954	83424	KIT, ROUND MAGNETIC SWITCH	-
NS	-	83382	HARNESSE, EMI TO EBOX	-
NS	4CT687	83282	HARNESSE PFC EBOX TO MOTOR AND DOOR SWITCHES.	-

PERFECT FRY FILTER AREA

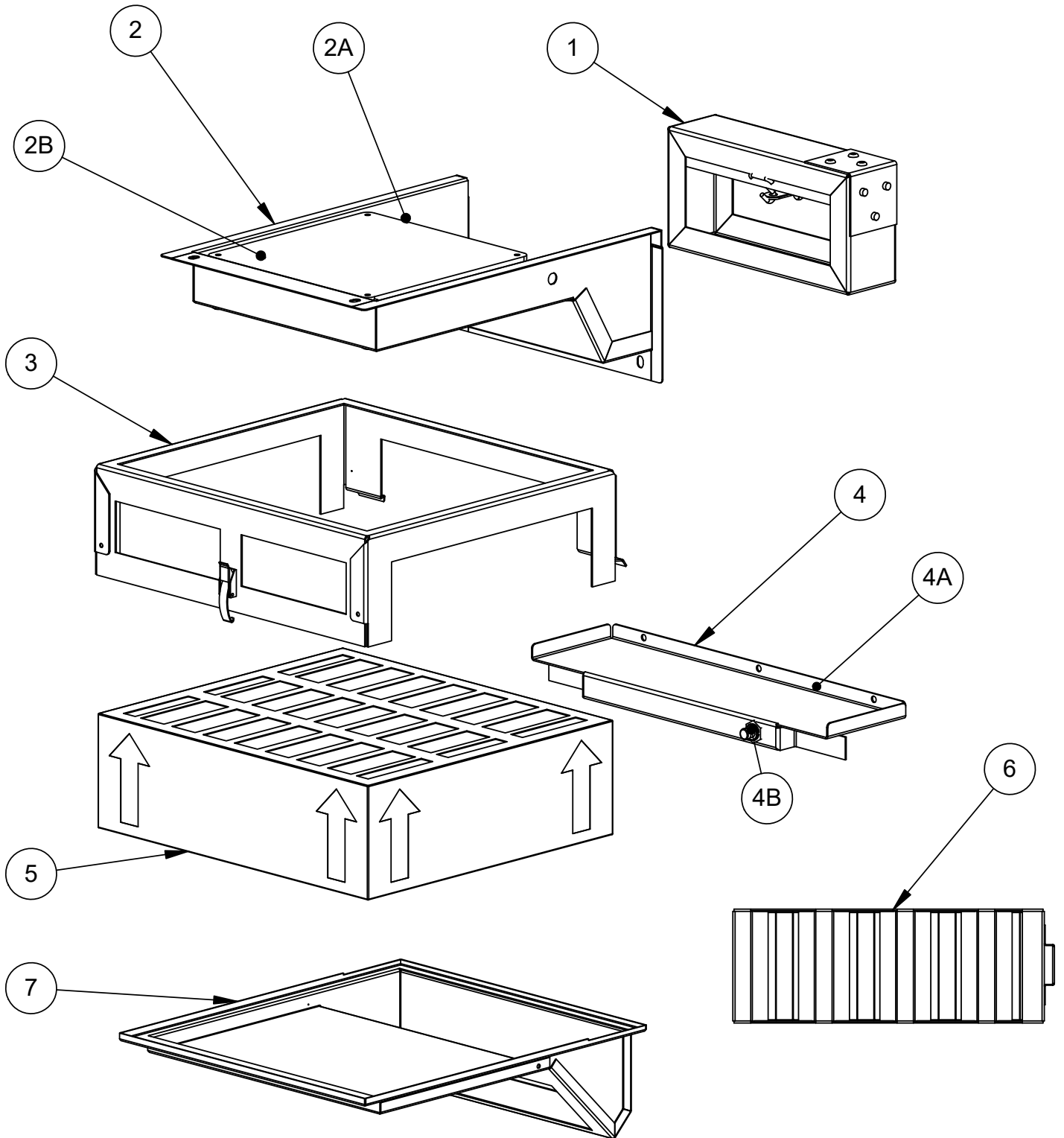

PERFECT FRY FILTER AREA

Item	Old P/N	New P/N	Description	QTY
1	6HT588	83252	DAMPER, FIRE ACTUATED	1
2	2HT723-C	83254	ASSEMBLY, AIRFLOW MODULE	1
3	6ST730-C	83067	BRACKET, FILTER CAGE	1
4	2DT955-C	83260	ASSEMBLY, AIR FILTER SWITCH	1
4A	6ST891-C	83202	BRACKET, AIR FILTER SWITCH	1
4B	6HT726	83262	SWITCH, AIR FILTER	1
5	2FV803	83553	KIT, FILTER REPLACEMENT, EXPORT ONLY	1
5	2FK001	83543	2 STAGE FILTER	1
6	3HT727	83251	ASSEMBLY, GREASE FILTER	1
7	6ST728	83007	TRAY, GREASE FILTER	1
NS	6HT647	83210	1/8" ID PVC TUBING	-
NS	6HT711	83253	GASKET, MAIN FAN	-
NS	6CT001	83255	RECEPTACLE, JR 3 PIN	-
NS	6CT560	83261	TERM, MINI FIT JR CRIMP	-

PFA OIL VAT ASSEMBLY

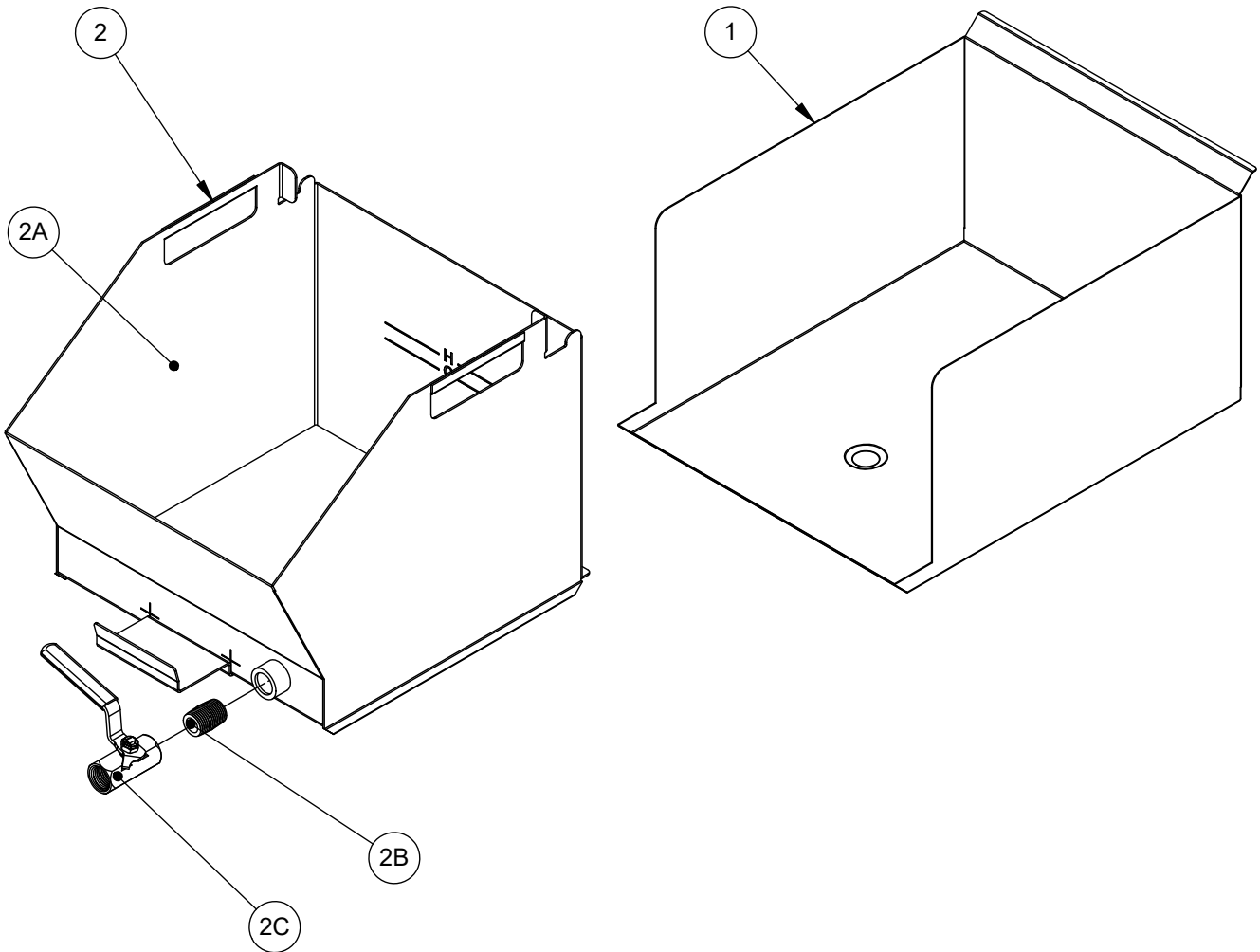

Item	Old P/N	New P/N	Description	QTY
1	6SA022-C	83182	TRAY, SPILL PFA	1
2	2DT003-C	83256	ASSEMBLY, VAT OIL 11 LITER	1
2A	6SA003-C	83010	VAT, OIL 11 LITER	1
2B	6DT934	83264	NIPPLE, .500 NPT CL SS	1
2C	6DT930	83263	VALVE, OIL MANUAL BALL SS	1
NS	2DT931	83653	KIT, OIL DRAINAGE	OPTION
NS	6HT739	83265	HOSE, OIL DRAINAGE	OPTION

PFC OIL VAT ASSEMBLY

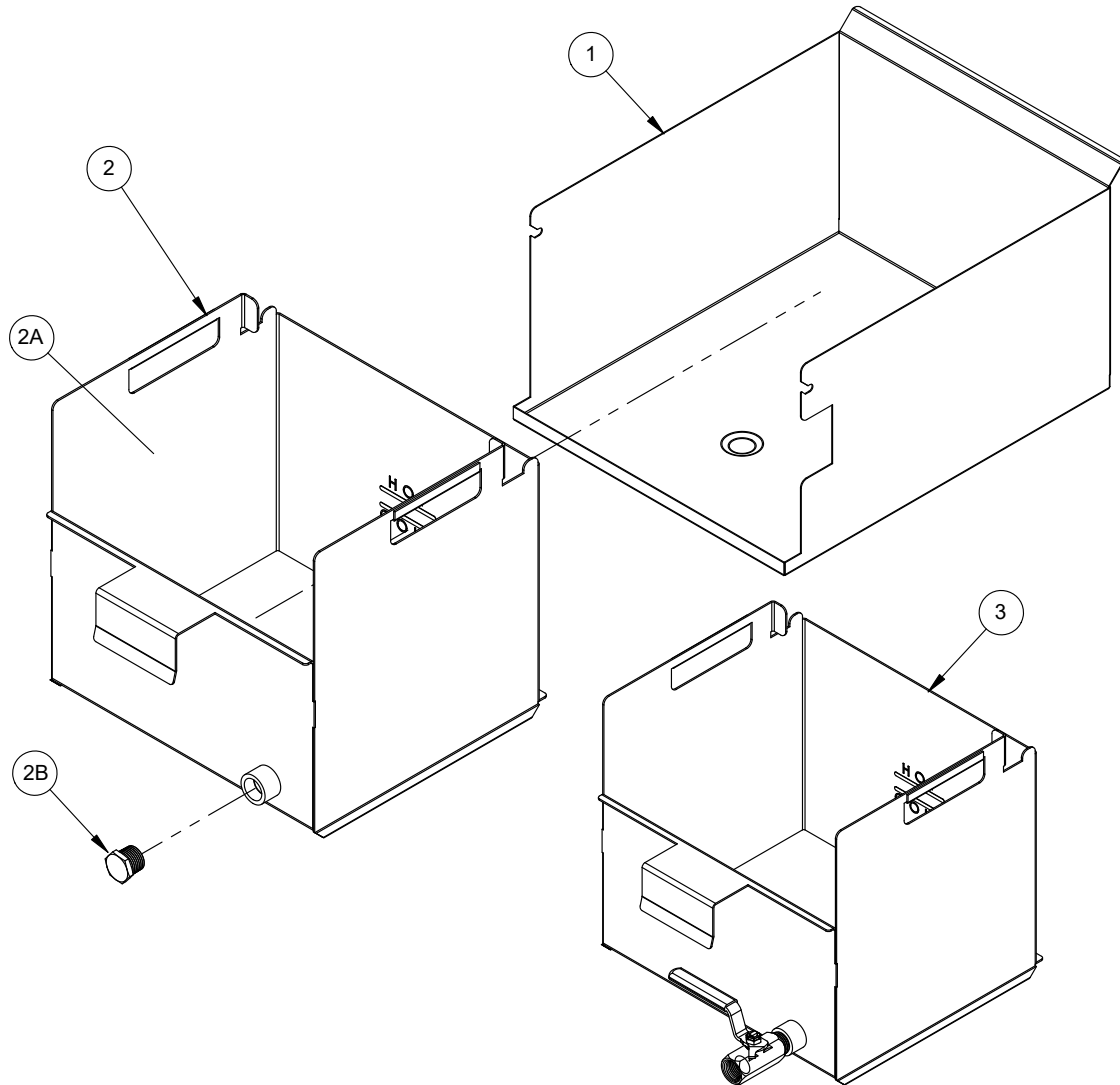

Item	Old P/N	New P/N	Description	PFC QTY
1	6ST734-C	83198	TRAY, SPILL PFC	1
2	2DT005-C	83273	ASSEMBLY, VAT OIL PFC	1
2A	6ST737-C	83012	VAT, OIL PFC	1
2B	2DT935	52808	PLUG, 1/2" HEX HEAD SS	1
3	2DT018	83274	KIT, OIL VAT PFC W/DRAIN VAVLE	-
NS	60212101	83277	VALVE T, OIL MANUAL BALL SS.	-
NS	2DT931	83653	KIT, OIL DRAINAGE	OPTION
NS	6HT739	83265	HOSE, OIL DRAINAGE	OPTION

PFA DOOR/DRAWER AREA

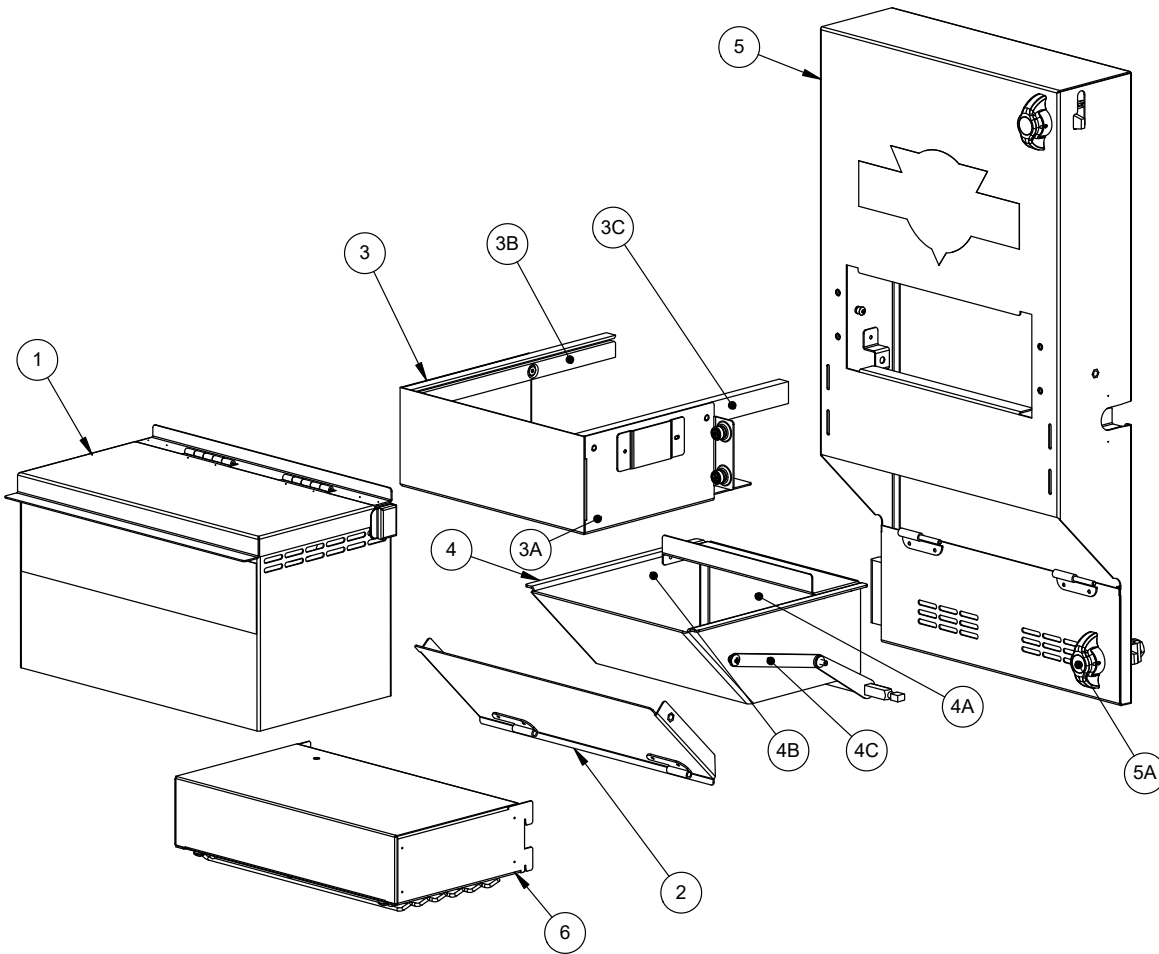

Item	Old P/N	New P/N	Description	QTY
1	2DT007-C	83203	ASSEMBLY, DRAWER AND LID	1
2	6SA021-C	83021	RAMP BASKET PFA	1
3	2DT008-C	83014	ASSEMBLY, DRAWER SLEEVE	1
4	2DT941-C	83217	ASSEMBLY, SHOVEL DRAWER PFA	1
4A	3DA001	83218	ASSEMBLY, DRAWER DOOR	1
4BV	6SA009-C	83223	ASSEMBLY, SHOVEL	1
4C	6SA006-C	83222	ARM UPPER DRAWER	2
5	2DT950-C	83722	ASSEMBLY, FRONT PANEL PFA	1
5A	6DA100	83059	LATCH, VICE WING NON-LOCKING	2
NS	6DA101	83060	LATCH, VICE WING LOCKING	OPTION
NS	6HA010	83066	SPRING, BASKET RAMP PFA	2
6	N/A	83548	HEAT LAMP, STANDARD, BOXED	-
6	N/A	83549	HEAT LAMP, SWZ/ITL, BOXED	-
6	N/A	83550	HEAT LAMP, EU, BOXED	-
6	N/A	83551	HEAT LAMP, RUSS, BOXED	-

PFC DOOR

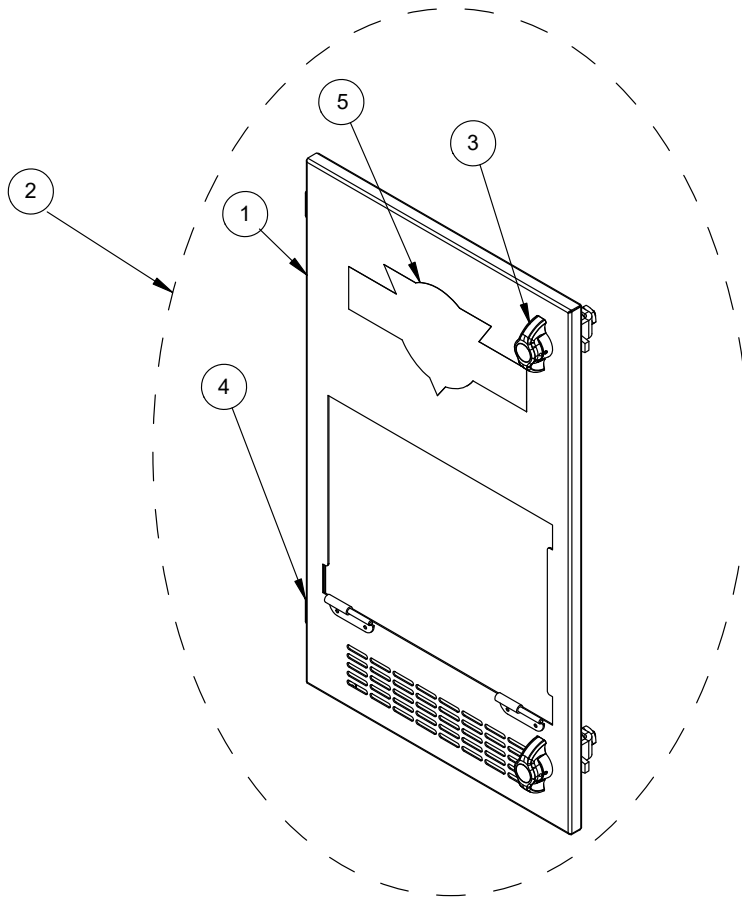

Item	OLD P/N	NEW P/N	Description	QTY
1	6ST814-C	83074	PANEL FRONT	1
2		83694	PANEL FRONT ASM	1
3	6DA100	83059	LATCH, VICE WING NON-LOCKING	2
4	2DT961	83700	HINGE MINI LIFT OFF	1
5	6LT893	83080	LABEL, PERFECT FRY LOGO LARGE	1
NS	2DT957	83698	SPRING EXTENSION DOOR	1
NS	6NT830	83150	SCREW, 6-32 X .250 BUTTON SOC CAP	4
NS	6NV175	83157	WASHER, LOCK #6 INTERNAL TOOTH	4
NS	6LT002	83078	LABEL, MAINTAINANCE GUIDE PFC	1
NS	4ST888-C	83694	FRONT DOOR ASM	-

PERFECT FRY HEATER ASSEMBLIES

FIREBAR STYLE

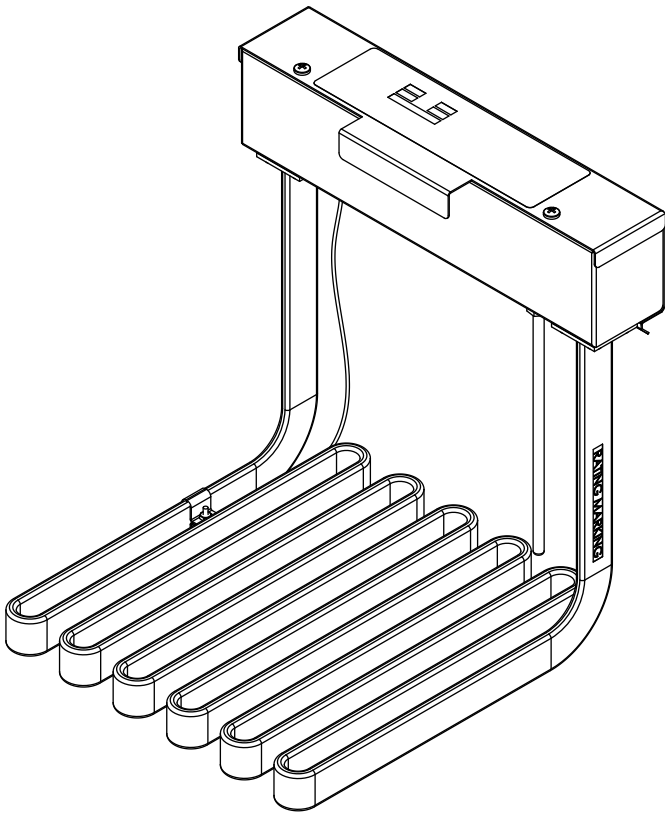

STANDARD

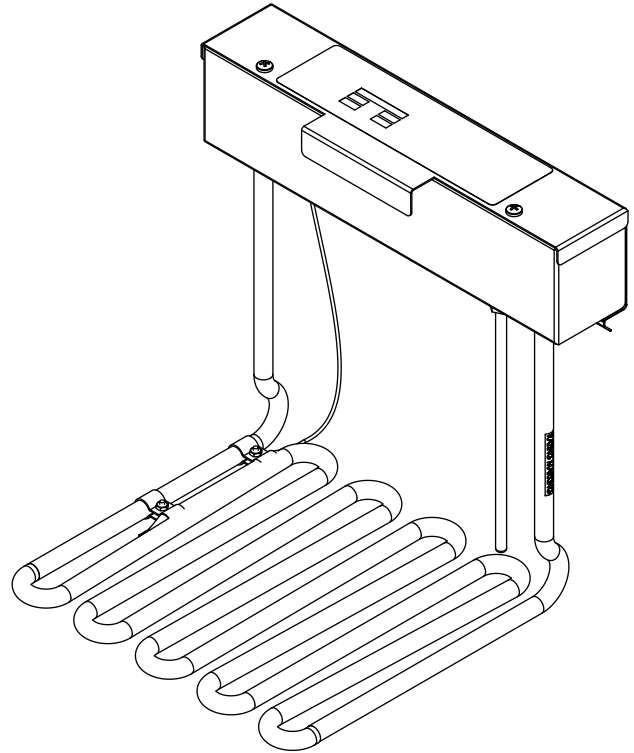

Item	Old P/N	New P/N	Description
STANDARD ELEMENTS			
8ET900		83151	ELEMENT ASSY, 5.7 kW, 240V
2ET922		83152	ELEMENT ASSY, 5.7 kW, 208V
2ET763		83153	ELEMENT ASSY, 3.75 kW, 240V
2ET760		83155	ELEMENT ASSY, 1.875 kW, 120V
2ET762		83420	ELEMENT ASSY, 3.0 kW, 240V
FIREBAR ELEMENTS			
2EA001		83339	ASM ELEMENT FIREBAR 240V 7200W (PFA ONLY)
2EA002		83340	ASM ELEMENT FIREBAR 400V 7200W (PFA ONLY)
2ET002		83341	ASM ELEMENT FIREBAR 400V 5700W

PFA 3 PHASE

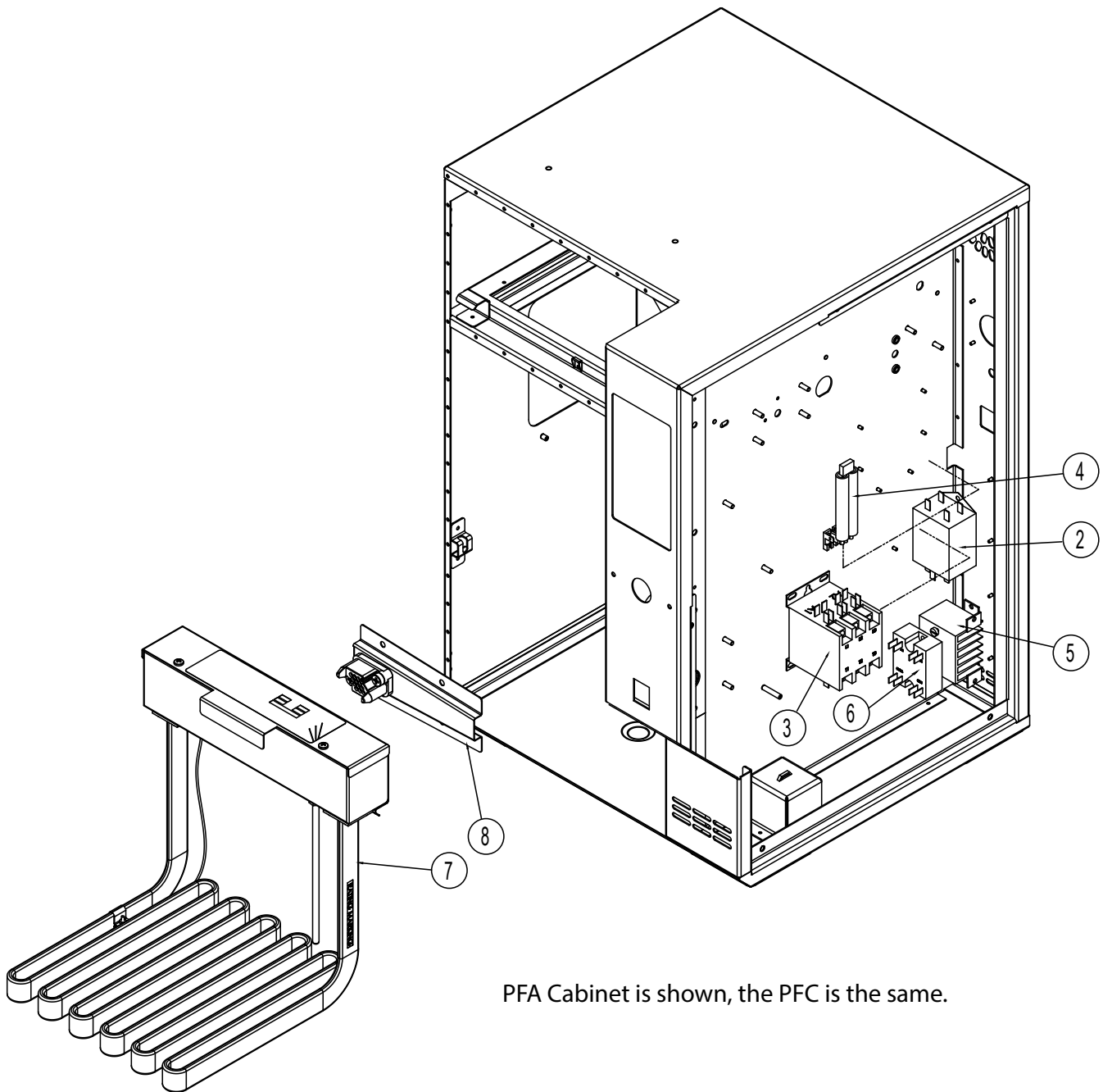

PFA Cabinet is shown, the PFC is the same.

Item	Old P/N	New P/N	Description	QTY
1	6SA038	83166	ASSY, FULL CABINET, PFA	-
2	6HT909	83302	FILTER, EMI, 20A 3 PHASE	-
3	60157203	83304	CONTACTOR, DP 3P 50A 600V 220 COIL	-
4	-	83623	CONTACTOR SNUBBER 3PH	-
5	6HA032	83310	HEAT SINK, DUAL RELAY	-
6	6HA031	83312	SSR, DUAL, 12V	-
7	2EA002	83340	ASM ELEMENT FIREBAR 400V 7200W	-
8	3CT766	83348	ASM 3 PH CONNECTOR WITH HARNESS	-
NS	2WT800-C	83674	E BOX 3 PHASE SERVICE KIT	-

EBOX

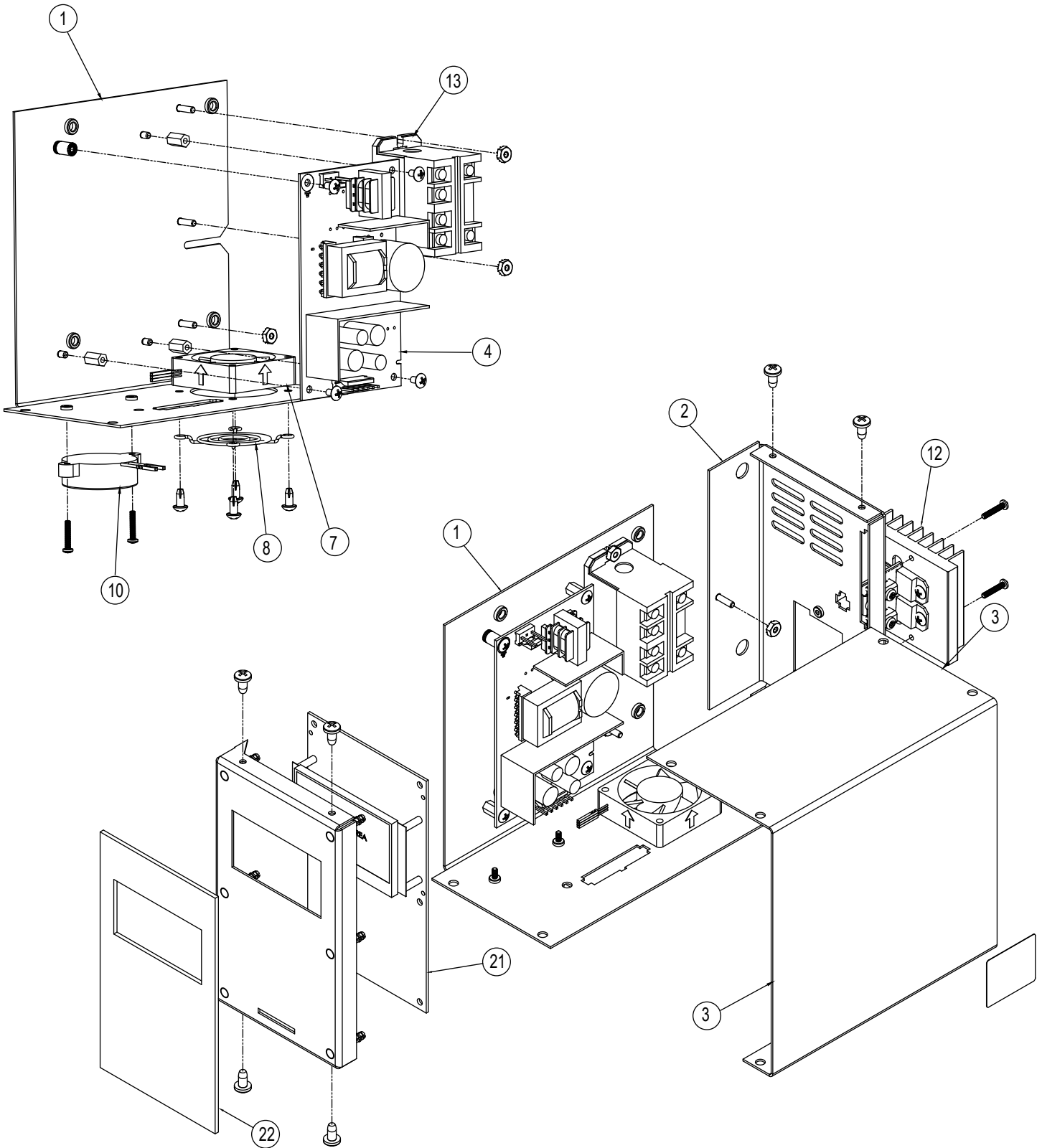

EBOX

Item	P/N	Description	QTY
20	83609	EBOX, FRONT PANEL	1
21	83371	PCB ASSEMBLY, E BOX	1
22	83378	KEYPAD, STANDARD	1
1	83610	EBOX, LEFT BOTTOM PANEL	1
2	83611	EBOX, BACK PANEL W/OFFSET	1
3	83612	EBOX, RIGHT TOP COVER	1
4	83373	BOARD, POWER SUPPLY, 12V	1
9	83061	SCREW, 6-32 X .250 TRUSS PH SS	4
7	83421	FAN, E BOX 12V, TERMINATED	1
8	83376	FAN GUARD, EBOX	1
10	83422	BUZZER, E BOX, TERMINATED	1
12	83375	ASSEMBLY, SCR BOARD	1
13	83372	RELAY, 12VAC, 2 POLE	1
17	83300	HARNESS, EBOX PCB TO 24 PIN PLUG	1
18	83301	HARNESS, EBOX POWER	1
19	83366	HARNESS, EBOX PCB TO 20 PIN PLUG	1
	83299	E BOX SERVICE KIT, 1 PH	1
	83299	E BOX SERVICE KIT, 3 PH	1

FIRE SYSTEM

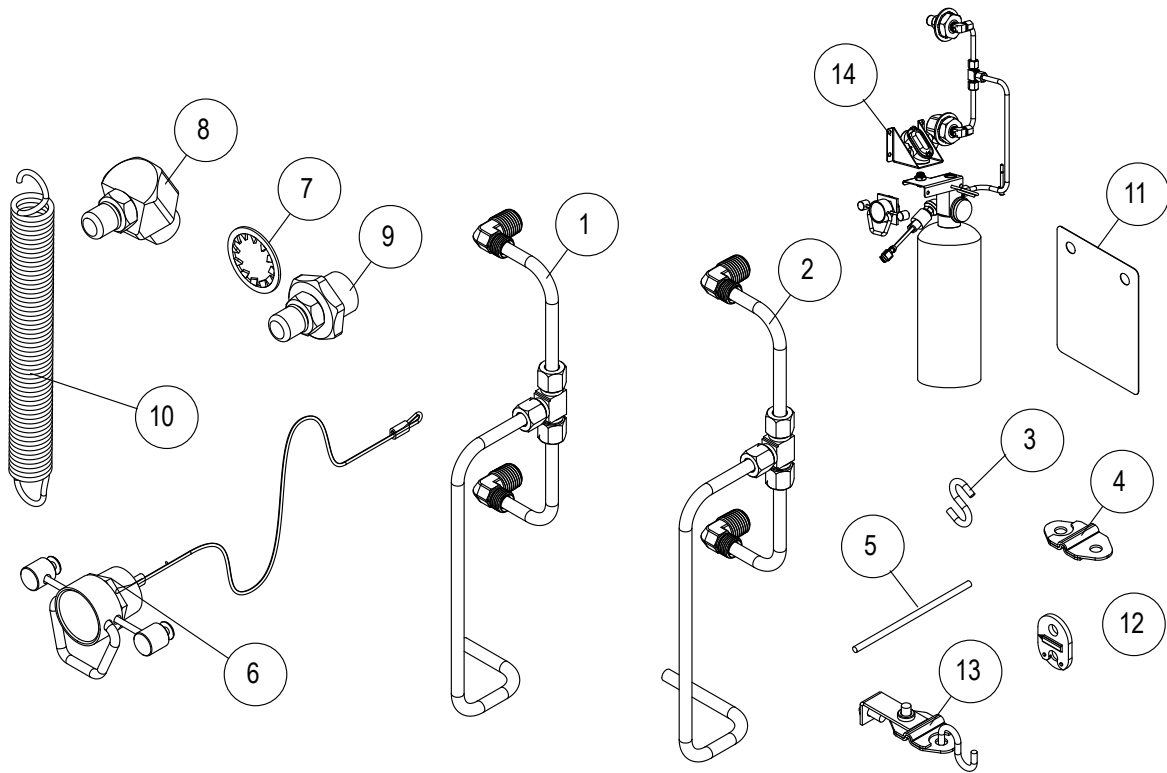

Item	Old P/N	New P/N	Description	QTY
1	6GT011	83083	ASSY, WET CHEM DIST, PFA	-
2	6GT011	83086	ASSY, WET CHEM DIST, PFC	-
3	6GT597	83088	S HOOK	-
4	6FP00601	83089	FUSIBLE LINK, 250°F (FOR UNITS MANUFACTURED AFTER 5/2016)*	-
5	6GT886	83091	BREAK ROD, RED, MANUAL PULL	-
6	-	83096	ASSY, MANUAL PULL WITH CABLE	-
7	6NT006	83102	7/8" LOCK WASH, INTERNAL TOOTH	-
8	2GT002	83110	ASSY, LOWER NOZZLE, WET CHEM	-
9	2GT003	83111	ASSY, UPPER NOZZLE, WET CHEM	-
10	-	83787	SPRING, FIRE MASTER	-
NS	6ST709-11	83207	BRACKET, FUSIBLE LINK TAB	-
11	6GV013	83350	FIREMASTER INSPECTION TAG	-
12	6GT587	83658	LINK, FUSIBLE, 280°F (FOR UNITS MANUFACTURED BEFORE 5/2016)*	-
13	6FP007	83659	KIT, ASSY, FUSIBLE LINK TAB W/ LINK	-
14	2DT943-C	83660	KIT, FIRE MASTER WET CHEMICAL	1
NS	2DT960	83661	KIT, FUSIBLE LINK, CAPS	-
NS	2GT004-C	83663	ASM EMPTY FIREMASTER NO CHARGE	-
NS	2DT944-C	83678	KIT, FIREMASTER AFTER DISCHARGE	-
NS	2DT942-C	83693	DRY TO WET CHEM RETFIT KIT	-
NS	2FP001-CL	83701	KIT FUSIBLE LINK/CAPS (FOR UNITS MANUFACTURED AFTER 5/2016)	-
NS	-	83120	FIREMASTER CLAMP GASKET	-
NS	-	83785	EXTINGUISHER CLAMP KIT.	-

* Per NAFPA 17A fusible links must be replaced every 6 months