



Visit www.clevelandrange.com to locate a service or sales representative in your area.



TR Gas Braising Pan

Installation, Operation, Maintenance, Parts & Service

This manual is updated as new information and models are released. Visit our website for the latest manual.

Models:

- SGL-30-TR
- SGL-40-TR
- SGM-30-TR
- SGM-40-TR



For your future reference.

Model # _____

Serial # _____

Model # & Serial #.
(Open front panel to view rating label.)



Read the manual thoroughly.
Improper installation, operation or maintenance can cause property damage, injury or death.

TABLE OF CONTENTS

Statement of Responsibilities 1

For your Safety 2

Installation 4

Operating Instructions 7

Cleaning Instructions 8

Preventative Maintenance 9

Trouble Shooting & Maintenance 10

Service Parts 12



STATEMENT OF RESPONSIBILITIES / DÉCLARATION DES RESPONSABILITÉS / DECLARACIÓN DE RESPONSABILIDADES

This document is for use by experienced and trained Qualified Cleveland Range, LLC Authorized Service Representatives who are familiar with both the safety procedures, and equipment they service. Cleveland Range, LLC assumes no liability for any death, injury, equipment damage, or property damage resulting from use of, improper use of, or failure to use the information contained in this document. Cleveland Range, LLC has made every effort to provide accurate information in this document, but cannot guarantee that this document does not contain unintentional errors and omissions.

The information in this document may be subject to technical and technological changes, revisions, or updates. Cleveland Range, LLC assumes no liability or responsibility regarding errata, changes, revisions, or updates.

Qualified Cleveland Range, LLC Authorized Service Representatives are obligated to follow industry standard safety procedures, including, but not limited to, OSHA regulations, and disconnect / lock out / tag out procedures for all utilities including steam, and disconnect / lock out / tag out procedures for gas, electric, and steam powered equipment and / or appliances.

All utilities (gas, electric, water and steam) should be turned OFF to the equipment and locked out of operation according to OSHA approved practices during any servicing of Cleveland Range equipment

Qualified Cleveland Range, LLC Authorized Service Representatives are obligated to maintain up-to-date knowledge, skills, materials and equipment.

Ce document est destiné à l'usage des Représentants de Service qualifiés et autorisés de Cleveland Range, LLC qui possèdent l'expérience et la formation ainsi que la bonne connaissance des mesures de sécurité et du matériel qu'ils entretiennent.

Cleveland Range, LLC décline toute responsabilité pour tout cas de décès, blessure, dommage matériel ou dommage aux biens résultant de l'utilisation, de la mauvaise utilisation ou du manquement d'utilisation des renseignements contenus dans ce document.

Cleveland Range, LLC s'est efforcé à fournir des renseignements précis dans ce document mais ne peut garantir que ce document soit exempt d'erreurs et d'omissions non intentionnelles.

Les renseignements contenus dans ce document peuvent être assujettis à des changements techniques et technologiques, des révisions ou des mises à jour.

Cleveland Range, LLC décline toute obligation ou responsabilité concernant les errata, modifications, révisions ou mises à jour.

Les Représentants de Service qualifiés et autorisés de Cleveland Range, LLC sont tenus de se conformer aux mesures de sécurité normalisées de l'industrie, y compris, mais sans s'y limiter, les réglementations de l'OSHA, les procédures de débranchement / verrouillage / étiquetage relatives à tous les services publics, dont l'approvisionnement en vapeur, et les procédures de débranchement / verrouillage / étiquetage relatives aux équipements et/ou appareils fonctionnant au gaz, à l'électricité et à la vapeur.

Au cours de tout entretien d'un appareil Cleveland Range, tous les services publics (gaz, électricité, eau et vapeur) doivent être FERMÉS au niveau de l'appareil et le dispositif de fonctionnement doit être verrouillé suivant les pratiques approuvées de l'OSHA.

Les Représentants de Service qualifiés et autorisés de Cleveland Range, LLC sont tenus d'actualiser en permanence leurs connaissances, compétences, matériel et équipement.

Este documento está destinado para el uso de los Representantes de Servicio calificados y autorizados de Cleveland Range, LLC quienes cuentan con la experiencia y la capacitación así como el buen conocimiento de las medidas de seguridad y de los equipos que mantienen.

Cleveland Range, LLC, declina toda responsabilidad en caso de cualquier fallecimiento, lesiones, daños al equipo o daños a la propiedad resultantes de la utilización, del uso indebido o de la falta de utilización de la información provista en este documento.

Cleveland Range, LLC se ha esforzado en suministrar información precisa en este documento, pero no puede garantizar que este documento esté exento de errores y de omisiones no intencionales.

La información contenida en este documento podría estar sujeta a cambios técnicos o tecnológicos, revisiones o actualizaciones. Cleveland Range, LLC declina toda obligación o responsabilidad con respecto a erratas, modificaciones, revisiones o actualizaciones.

Los Representantes de Servicio calificados y autorizados de Cleveland Range, LLC tienen la obligación de seguir los procedimientos estándar de seguridad de la industria; los cuales incluyen pero no se limitan a los reglamentos de la OSHA (La Administración de la Seguridad y Salud Ocupacionales), los procedimientos de desconexión, cierre y etiquetado relativos a todos los servicios públicos incluyendo el suministro de vapor y los procedimientos de desconexión, cierre y etiquetado para los equipos y/o aparatos que funcionan a base de gas, electricidad o vapor.

Cuando se esté dando servicio o mantenimiento a un aparato de Cleveland Range, todos los servicios públicos (gas, electricidad, agua y vapor) deben estar APAGADOS para el equipo en cuestión y se debe seguir el procedimiento de cierre de operaciones de acuerdo con las prácticas aprobadas por la OSHA.

Los Representantes de Servicio calificados y autorizados de Cleveland Range, LLC tienen la obligación de actualizar constantemente sus conocimientos, destrezas, materiales y equipamiento.

FOR YOUR SAFETY / POUR VOTRE SÉCURITÉ / PARA SU SEGURIDAD

FOR YOUR SAFETY

Do not store or use gasoline or any other flammable liquids and vapours in the vicinity of this or any other appliance.

POUR VOTRE SÉCURITÉ

Ne pas entreposer ou utiliser d'essence ou d'autres liquides ou vapeurs inflammables à proximité de cet appareil ou de tout autre appareil.

PARA SU SEGURIDAD

No guarde ni use gasolina o cualesquiera otros líquidos o vapores inflamables en las cercanías de éste o cualquier otro aparato.

WARNING: Improper installation, operation, adjustment, alteration, service or maintenance can cause property damage, injury or death. Read the installation and operating instructions thoroughly before installing, operating or servicing this equipment.

AVERTISSEMENT : Toute mauvaise pratique en matière d'installation, de fonctionnement, de réglage, de modification, d'entretien ou de maintenance peut causer des dommages matériels, des blessures ou la mort. Lisez la totalité des instructions d'installation et d'utilisation avant d'installer, d'utiliser ou d'entretenir cet équipement.

ADVERTENCIA: La indebida instalación, operación, ajuste, modificación, servicio o mantenimiento puede ocasionar daños a la propiedad, lesiones o muerte. Lea detenidamente las instrucciones de instalación y de operación antes de instalar, poner a funcionar o dar servicio a este equipo.

Ne pas pulvériser des aérosols dans le voisinage de cet appareil alors qu'il est en fonctionnement.

Cet appareil ne doit pas être utilisé par des personnes dont les capacités physiques, sensorielles ou mentales sont réduites, ou des personnes dénuées d'expérience ou de connaissance, sauf si elles ont pu bénéficier, par l'intermédiaire d'une personne responsable de leur sécurité, d'une surveillance ou d'instructions préalables concernant l'utilisation de l'appareil.

Cet appareil n'est pas destiné à être utilisé par des enfants et ils doivent être surveillés pour s'assurer qu'ils ne jouent pas avec l'appareil.

Affichez à un endroit bien visible les instructions à suivre dans le cas où l'utilisateur sent une odeur de gaz. Ces informations seront obtenues auprès de votre fournisseur de gaz local.

Ne pas obstruer le flux d'air de combustion et de ventilation.

Conservez ce manuel pour votre référence.

Do not spray aerosols in the vicinity of this appliance while it is in operation.

This appliance is not to be used by persons with reduced physical, sensory or mental capabilities, or lack of experience and knowledge, unless they have been given supervision or instruction concerning use of the appliance by a person responsible for their safety.

This appliance is not for use by children and they must be supervised not to play with it.

Post in a prominent location, instructions to be followed in the event the user smells gas. This information shall be obtained by consulting your local gas supplier.

Do not obstruct the flow of combustion and ventilation air.

Retain this manual for your reference.

No pulverice aerosoles en las proximidades de este aparato mientras está en funcionamiento.

Este aparato no debe ser utilizado por personas con capacidades físicas, sensoriales o mentales reducidas, o que no tengan la experiencia y los conocimientos adecuados, a menos que estas personas hayan recibido supervisión e instrucciones en cuanto al uso del aparato por la persona responsable de la seguridad de ellas.

Este aparato no debe ser usado por los niños y ellos deben ser supervisados para que no jueguen con el aparato.

No obstruya el flujo del aire de combustión y de ventilación.

Guarde este manual para su referencia.



WARNING / AVERTISSEMENT / ADVERTENCIA



Improper installation, operation, adjustment, alteration, service or maintenance can cause property damage, injury or death. Read the installation and operating instructions thoroughly before installing, operating or servicing this equipment. / Toute mauvaise pratique en matière d'installation, de fonctionnement, de réglage, de

modification, d'entretien ou de maintenance peut causer des dommages matériels, des blessures ou la mort. Lisez la totalité des instructions d'installation et d'utilisation avant d'installer, d'utiliser ou d'entretenir cet équipement. / La indebida instalación, operación, ajuste, modificación, servicio o mantenimiento puede ocasionar daños a la propiedad, lesiones o muerte. Lea detenidamente las instrucciones de instalación y de operación antes de instalar, poner a funcionar o dar servicio a este equipo.



Keep hands away from moving parts and pinch points. / Gardez les mains loin des pièces mobiles et des points de pincement. / Mantenga las manos lejos de piezas móviles y puntos de presión muy localizada.



Surfaces and product may be hot! Wear protective equipment. / Les surfaces et le produit peuvent être chauds! Portez un équipement de protection. / ¡Las superficies y el producto pueden estar calientes! Utilice equipo protector.



Hot product and surfaces. / Produit et surfaces chaudes. / Producto y superficies calientes.

Do not touch. / Ne pas toucher. / No la toque



Do not climb, sit or stand on equipment. / Il ne faut pas monter, s'asseoir ni se tenir debout sur l'équipement. / No subirse, ni sentarse ni pararse sobre el equipo.



Stand clear of product discharge path when discharging hot product. / Écartez-vous du chemin de décharge d'un produit chaud. / Permanezca alejado de la ruta de descarga del producto al vaciar producto caliente.



Do not lean on or place objects on lip. / Ne vous penchez pas sur ou ne placez pas des objets sur la lèvres. / No se apoye ni coloque objetos en el labio.



Inspect unit daily for proper operation. / Inspectez l'unité tous les jours pour son bon fonctionnement. / Inspeccione diariamente el funcionamiento correcto de la unidad.



Keep appliance and area free and clear of combustibles. / Gardez l'appareil et son entourage libre de tous combustibles. / Mantenga el aparato y el área libres de combustibles.



Do not attempt to operate this appliance during a power failure. / N'essayez pas de faire fonctionner cet appareil lors d'une panne de courant. / No intente poner en marcha este aparato durante un fallo de suministro eléctrico.



Unit exhaust contains carbon monoxide. Operate only under a properly functioning hood with adequate make-up air. / L'échappement de l'unité émet du monoxyde de carbone. Exploiter uniquement sous une hotte fonctionnant correctement avec une source adéquate d'air d'appoint. / El escape de la unidad contiene monóxido de carbono. Operar solamente bajo una campana en buen funcionamiento con aire de relleno adecuado.



Floor may become slippery from product spillage. / Déversement de produit peut causer de plancher à être glissant. / Derrame de producto puede causar piso a ser resbaladizo.



Unit must be anchored as per manual. / Unité doit être ancrée selon les directives du manuel. / Unidad debe estar fijado según el manual.



Heavy / Lourd / Pesado

Team or mechanical lift. / Équipe ou remontée mécanique. / Equipo o elevador mecánico.

IMPORTANT / IMPORTANT / IMPORTANTE

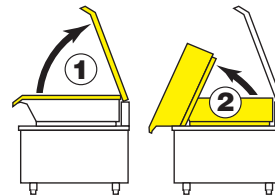

Lift lid before tilting skillet.

Ôtez le couvercle avant d'incliner la chaudière à frire.

Levante la tapa antes de inclinar la sartén.

SERVICING / ENTRETIEN / SERVICIO



Shut gas supply off prior to servicing. / Fourniture de gaz fermée au loin avant d'entretenir. / Suministro de gas cerrado apagado antes del mantenimiento.



Remove electrical power prior to servicing. / Coupez l'alimentation électrique avant l'entretien. / Desconnecte la energía eléctrica antes de darle servicio.

Risk of electric shock. / Risque de choc électrique. / Riesgo de choque eléctrico.



Have a qualified service technician maintain your equipment. / Demandez à un technicien en entretien et en réparation qualifié d'effectuer l'entretien de votre équipement. / Haga que un técnico de servicio calificado mantenga su equipo

INSTALLATION

GENERAL

Insure gas and electrical supplies match rating plate.

The rating plate is located directly behind the upper front panel (left side). For easy access, remove the two screws securing the upper front panel and hinge the lower front panel downwards. Gas type, burner ratings and electrical requirements are stated on the plate.

Installation of the unit must be accomplished by qualified installation personnel working to all applicable local and national codes.

This equipment is built to comply with applicable standards for manufacturers. Included among those approval agencies are: UL, A.G.A., NSF, ASME/N.Bd., CSA, CGA, ETL, and others. Many local codes exist, and it is the responsibility of the owner/installer to comply with these codes.

Observe all clearance requirements. Do not obstruct the flow of combustion and ventilation air.

RECEIVING INSPECTION

Before unpacking visually inspect the unit for evidence of damage during shipping.

If damage is noticed, do not unpack the unit, follow shipping damage instructions.

SHIPPING DAMAGE INSTRUCTIONS

If shipping damage to the unit is discovered or suspected, observe the following guidelines in preparing a shipping damage claim.

1. Write down a description of the damage or the reason for suspecting damage as soon as it is discovered. This will help in filling out the claim forms later.
2. As soon as damage is discovered or suspected, notify the carrier that delivered the shipment.
3. Arrange for the carrier's representative to examine the damage.
4. Fill out all carrier claims forms and have the examining carrier sign and date each form.

APPROXIMATE WEIGHTS

Model #	Unit	Unit with shipping box
SGL-30-TR	440 lbs.	480 lbs.
SGL-40-TR	520 lbs.	560 lbs.



UNCRATING

CAUTION:

Straps under tension and will snap when cut. Carton may contain staples and skid contains nails. Use proper safety equipment and precautions. Unit is heavy. Use adequate help or lifting equipment as needed.

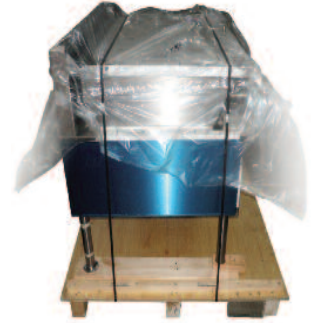

1. Cut straps and remove box.

2. Cut straps on unit.



3. Remove screws from back of flanged feet (x6).



4. Remove nails to free blocks on front legs.

VENTILATION

Gas fired units are only to be installed under a ventilation hood in a room which has provisions for adequate make up air. Further information can be obtained by referring to the U.S.A. National Fire Protection Associations NFPA96 regulations. These standards have also been adopted by the National Building Code in Canada.



CLEARANCE REQUIREMENTS/ DRAIN LOCATIONS

This unit must be installed in accordance with the clearances shown on the rating label which is adhered to the unit.

FOR YOUR SAFETY. Keep the appliance area free and clear of combustible materials.

POSITIONING

This unit must be installed in accordance with the clearances shown on the rating label which is adhered to the unit.

Caution:

The actuator is mounted in center of unit, if using a fork truck, lift as illustrated.

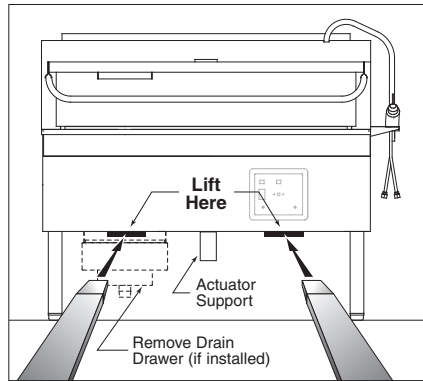

- 1 Position the unit in its permanent location.
2. Level skillet by means of adjustable stainless steel feet. For your convenience a foot wrench is taped to one leg. Use a spirit level and level unit four ways; across front and back and down left and right edges.
3. Once positioned and leveled, permanently secure the unit's flanged feet to the floor using 5/16" lag bolts and floor anchors (supplied by the installer). Three bolts are required to secure each of the flanged feet.
4. Seal joints of flanged feet with a silicone sealant.
5. Remove any protective material covering stainless steel panels.

GAS

ENSURE THE GAS SUPPLY MATCHES THE KETTLE'S REQUIREMENTS AS STATED ON THE RATING PLATE.

Installation must conform, with local codes or in the absence of local codes, with the National Fuel Gas Code ANSI Z223.1/NFPA 54, or the Natural Gas and Propane Installation Code, CSA B149.1 and B149-2 (Canada).

The appliance and its individual shut-off valve must be disconnected from the gas supply piping system during any pressure testing of that system at test pressures in excess of 1/2 psi (3.45 kPa).

The appliance must be isolated from the gas supply piping system by closing its individual manual shut-off valve during any pressure testing of the gas supply piping system at test pressures equal to or less than 1/2 psi (3.45 kPa).

It is recommended that a sediment trap (drip leg) be installed in the gas supply line. If the gas pressure exceeds 1/2 psi (3.45 kPa), a pressure regulator must be installed, to provide a maximum of 1/2 psi (3.45 kPa) gas pressure to the gas control valve.

Connect the gas line to the manual valve located at the rear left hand side. Use pipe joint sealant that is approved for use with liquefied petroleum gas.

A pressure tap is supplied with each unit and is installed on the manifold. The gas pressure must be checked when unit is installed, to ensure unit gas pressure is the same as specified on the rating plate. For access to the pressure tap, remove front panel, turn power switch to the 'OFF' position as a precaution and hinge front panel downwards. The pressure tap is located behind the front shield. If necessary, pressure adjustments can be made at the pressure regulator which is installed on the manifold. For easy access to the pressure regulator, view along left side of unit from underneath. Once pressure test is completed, turn power switch and thermostat to the 'OFF' position. Raise lower front panel back into position.

ELECTRICAL

ENSURE THE ELECTRICAL SUPPLY MATCHES THE UNIT'S REQUIREMENTS AS STATED ON THE RATING LABEL.

A cord and plug are supplied with the 115 volt unit. Simply plug the unit into any grounded outlet rated for a minimum of 10 amps.



WARNING:

Electrical Grounding Instructions.

This unit is equipped with a three-prong (grounding) plug for your protection against shock hazard and should be plugged directly into a properly grounded three-prong receptacle. Do not cut or remove the grounding prong from this plug.

Standard supply voltage is 115 volts A.C., however, optional A.C. voltages can be supplied on special order. A separate fused disconnect switch must be supplied and installed in the high voltage electrical supply line. The unit when installed, must be electrically installed and grounded in accordance with local codes, or in the absence of local codes, with National Electrical Code, ANSI/NFPA 70-1990 (USA) or the Canadian Electrical Code, CSA C22.2, Part 1 (Canada)

When a unit is ordered and built for 208/240 volt, the supply line must be connected to the wiring terminations located inside the console. Wiring diagram is located on the bottom side of component enclosure cover.

The wiring diagram is located on the back of the console access panel.

INSTALLATION CHECKS

Although the unit has been thoroughly tested before leaving the factory, the installer is responsible for ensuring the proper operation of unit once installed.

1. Supply power to the unit by placing the fused disconnect switch to the "ON" position.
2. Turn on main gas supply to unit. Open the unit's shut-off valve (located at lower rear left).
3. Toggle Switch to the "HI" or "LO" position.
4. For your safety the unit is equipped with a power interrupter which automatically shuts off the gas supply to the burners whenever the unit is raised more than 8°.
5. Turn temperature control to maximum. Tilt pan until heat indicator light turns off and heating system shuts down. The pan should be on a 5-10° angle.
6. Lower pan. Heat indicator light will re-light and heating system will re-energize.
7. Unit will continue to heat, heat indicator light will remain on until temperature is reached. Then the heat indicator light will cycle OFF indicating the heating system has shut off. The heat indicator light will continue to cycle ON and OFF as the heating system cycles ON and OFF maintaining the desired temperature.
8. Toggle ON / OFF Switch to the "ON" position.
9. Check carbon monoxide is less than 0.08 percent in an air-free sample of the flue gases. See FREE AIR CALCULATION procedure in "Maintenance Procedures & Parts Lists" manual.

CLEANING

After installation the unit must be thoroughly cleaned and sanitized prior to cooking

OPERATING INSTRUCTIONS

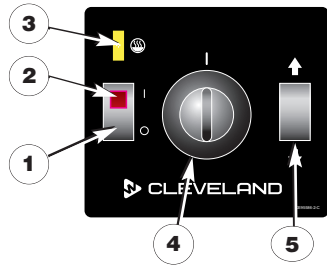

- | # | DESCRIPTION |
|-----|------------------------------------|
| 1. | On-Off Switch |
| 2. | Power Indicator Light (Red) |
| 3. | Heat Indicator Light (Yellow) |
| 4. | Temperature Dial |
| 5. | Power Tilt Switch |
| 6. | Manual Tilt Override |
| 7. | Tangent Draw-Off Valve (not shown) |
| 8. | Faucet (not shown) |
| 9. | Gas Shut Off Valve |
| 10. | Flue |

WARNING / AVERTISSEMENT / ADVERTENCIA



If for any reason this unit is not functioning correctly **DO NOT OPERATE**. Contact your authorized service agent.

WARNING:

If ignition fails and/or the control system goes into lockout, set power switch to the "OFF" position.

Wait 5 minutes then repeat steps 1 through 3. If the problem persists, have a qualified serviceman check the system.



OPERATING THE UNIT

1. Perform daily startup inspection.
2. Turn Power Switch to the ON position. The yellow Heat Indicator Light will indicate pan is heating.
3. **MANUAL TILT:** To raise pan, raise the cover and turn the crank clockwise. To lower pan, turn counterclockwise.
POWER TILT: To raise pan, raise the cover and press up on the tilt switch. To lower pan, press down on the tilt switch.



OPEN COVER BEFORE TILTING PAN

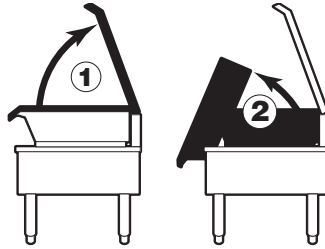

FOR YOUR SAFETY: A power interrupter will automatically shut off the power to the elements whenever the skillet is raised more than 1/2" (13mm).

IMPORTANT: Before commencing to cook, ensure pan is in the lowered position.

4. To preheat, set Temperature Dial to desired cooking temperature.
5. Allow skillet to preheat for approximately 15-30 minutes.
6. Once preheated, insert product in skillet and adjust Temperature Dial to required cooking temperature.
7. If desired, once product has cooked, it can be held prior to serving at a lower temperature setting.
8. When cooking is completed, set Temperature Dial and Power Switch to the OFF position.
9. Pour the contents of the unit into an appropriate container by tilting the kettle forward or using discharge valve.

NOTE: Cleaning should be completed immediately after cooked foods are removed.



POWER TILT MANUAL OVERRIDE INSTRUCTIONS

NOTE: Once unit has been tilted there is now way to lower it until power is restored.



1. Remove plug.



2. Reach under skillet and remove tilt handle.



3. Insert handle onto pump shaft and turn.

OPERATING SUGGESTIONS

1. Turn power switch to the "OFF" position when skillet is not in use.
2. Allow skillet to preheat before adding product.
3. Always lift the spring assist cover before activating the tilt mechanism.
4. During an electrical power interruption, turn Power Switch to the OFF position. This unit cannot be made to operate without electrical power.

CLEANING INSTRUCTIONS



CARE AND CLEANING

Cooking equipment must be cleaned regularly to maintain its fast, efficient cooking performance and to ensure its continued safe, reliable operation. The best time to clean is shortly after each use (allow unit to cool to a safe temperature).

WARNINGS



Chloride Cleaners

Do not use detergents or cleansers that are chloride based or contain quaternary salt.



Wire Brush & Scrapers

Do not use a metal bristle brush or scraper.



Steel Pads

Steel wool should never be used for cleaning the stainless steel.

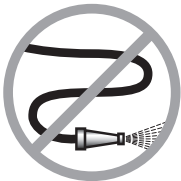

High Pressure Spray Hose

Unit should never be cleaned with a high pressure spray hose.



Stagnant Water

Do not leave water sitting in unit when not in use.

CLEANING INSTRUCTIONS

1. Turn unit off.
2. Remove drain screen (if applicable). Thoroughly wash and rinse the screen either in a sink or a dishwasher.
3. Prepare a warm water and mild detergent solution in the unit.
4. Remove food soil using a nylon brush.
5. Loosen food which is stuck by allowing it to soak at a low temperature setting.
6. Drain unit.
7. Rinse interior thoroughly.
8. If the unit is equipped with a **Tangent Draw-Off Valve**, clean as follows:
 - a) Disassemble the draw-off valve first by turning the valve knob counter-clockwise, then turning the large hex nut counter-clockwise until the valve stem is free of the valve body.
 - b) In a sink, wash and rinse the inside of the valve body using a nylon brush.
 - c) Use a nylon brush to clean tangent draw-off tube.
 - d) Rinse with fresh water.
 - e) Reassemble the draw-off valve by reversing the procedure for disassembly. The valve's hex nut should be hand tight only.
9. Using mild soapy water and a damp sponge, wash the exterior, rinse, and dry.

NOTES

- ⇒ For more difficult cleaning applications one of the following can be used: alcohol, baking soda, vinegar, or a solution of ammonia in water.
- ⇒ Leave the cover off when the kettle is not in use.
- ⇒ For more detailed instructions refer to Stainless Steel Equipment Care and Cleaning (www.nafem.org/resources/stainlesssteelfinal.doc) on Nafem's website (www.nafem.org).

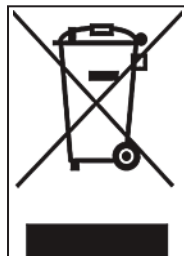

DISPOSAL INSTRUCTIONS

This unit is recyclable. Do not dispose in landfill.

The majority of the unit is composed of stainless steel. Other alloys and electrical components make up a small percentage of the total. Follow Federal, state and local regulations for disposal.



PREVENTATIVE MAINTENANCE

FOR MAINTENANCE AND REPAIRS CONTACT YOUR AUTHORIZED
MANITOWOC SERVICE AGENCY AND HAVE A QUALIFIED
SERVICE TECHNICIAN MAINTAIN YOUR EQUIPMENT.



Cleveland Range equipment requires little preventative maintenance. We do however provide the following guidelines for inspection and maintenance to keep your unit functioning at 100%.



DAILY PRE-STARTUP INSPECTION

1. Cover tilts up and down freely and is held in place when fully open.
2. Draw-Off Valve (if equipped) is installed and handle is in place.
3. Tilt hand wheel is tight (if equipped).
4. Tilt switch (if equipped) (5) is not broken and is functioning properly.
5. Pan tilts up and down correctly.
6. Temperature dial (3) is in place and functioning properly.
7. Red Light (2) comes on when unit is turned on.
8. Orange Light (4) is on when unit is heating.
9. Orange Light (4) is off when unit is tilted.

WARNING:



If for any reason this unit is not functioning correctly **DO NOT OPERATE**. Contact your authorized service agent.

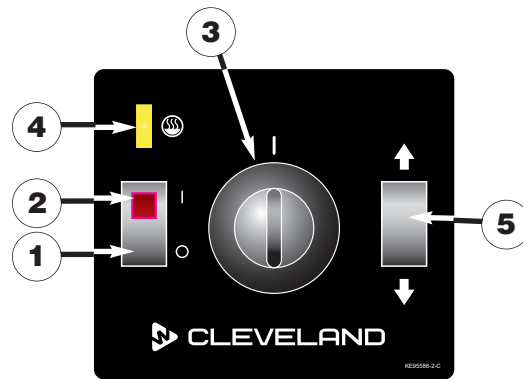

SIX MONTH SERVICE INSPECTION

1. Perform daily startup inspection.
2. There are no hydraulic oil leaks.
3. Adequate exhaust and makeup air is supplied to working area.
4. All panels are in place and securely fastened.

YEARLY SERVICE INSPECTION

1. Perform six month service inspection.
2. Inspect safety thermostat for proper connections.
3. Clean blower.
4. Perform free air calculation (see FREE AIR CACULATION).

TROUBLESHOOTING AND MAINTENANCE PROCEDURES

The following trouble shooting guide and maintenance procedures are meant to be used by Qualified Service Technician



For periodic maintenance recommendations see “Operators Manual”.

HINGE ADJUSTMENT INSTRUCTIONS

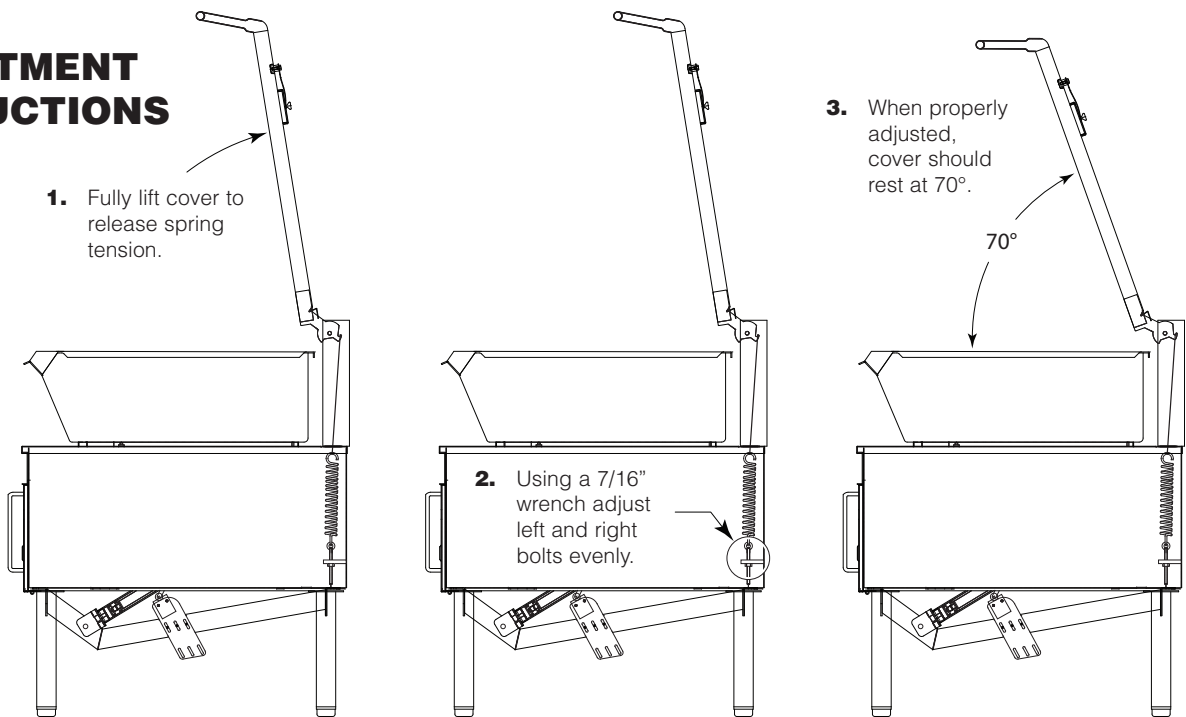

CALIBRATION INSTRUCTIONS

IMPORTANT: DO NOT ATTEMPT TO CALIBRATE THE THERMOSTAT

The electronic thermostat supplied with this skillet has been precisely calibrated at the factory and should not require field calibration.

SPARE PARTS LIST

ITEM ON.	DESCRIPTION	QTY.
KE55069-7	SAFETY THERMOSTAT	1
SK50905-1	LIGHT	1
KE52936-13	FUSE, 1 AMP, 250V	1
SK2498399	SHAFT ASSEMBLY, POTENTIOMETER	1
SK2474100	SWITCH, OP/OFF, 120V	1
SK2474101	SWITCH, OP/OFF, 220-240V	1
SK53838-30	TRANSFORMER	1
SK2343502	SWITCH, POWER TILT	1
KE52936-9	FUSE, 15 AMP, 250 V	1
SK2345100	THERMOSTAT SENSOR	1
SK2142002	TEMPERATURE SENSOR BOARD	1
KE5936-8	FUSE, 1.25 AMP, 250V	1
KE5936-7	FUSE, 2.5 AMP	1
KE5936-10	FUSE, 1.5 AMP, 250V	1
KE5936-11	FUSE, 0.5 AMP, 250V	1

TILT MECHANISM LUBRICATION

The hydraulic cylinder and the bronze bushings are all self-lubricating and require no lubrication.

FREE AIR CALCULATION

Insert drager pump tube 4" down the center of the flue and take one sample each of Carbon Dioxide (CO₂) and Carbon Monoxide (CO) and record results.

_____ % CO
_____ % CO₂
(PPM)

With results obtained for CO₂ use chart to determine dilution factor for gas type used.

_____ Dilution Factor

Enter these numbers in the following formula to determine the concentration of carbon monoxide in an air free sample of flue gas.

$$\text{Dilution Factor} \times \frac{\text{CO (PPM)}}{10,000} = \frac{\text{_____}}{\% \text{ Carbon Monoxide}}$$

Result must not exceed 0.08% carbon monoxide.

CARBON DIOXIDE IN SAMPLE (PERCENT)	FACTOR PROPANE GAS	FACTOR NATURAL GAS
4.0	3.50	3.05
4.2	3.33	2.90
4.4	3.18	2.77
4.6	3.04	2.65
4.8	2.92	2.54
5.0	2.80	2.44
5.2	2.69	2.34
5.4	2.59	2.26
5.6	2.50	2.18
5.8	2.41	2.10
6.0	2.33	2.03
6.2	2.26	1.97
6.4	2.19	1.91
6.6	2.12	1.85
6.8	2.06	1.80
7.0	2.00	1.74
7.2	1.94	1.70
7.4	1.89	1.65
7.6	1.84	1.61
7.8	1.79	1.56
8.0	1.75	1.53
8.2	1.71	1.49
8.4	1.67	1.45
8.6	1.63	1.42
8.8	1.59	1.39
9.0	1.56	1.36
9.2	1.52	1.33
9.4	1.49	1.30
9.6	1.46	1.27
9.8	1.43	1.24
10.0	1.40	1.22

SERVICE PARTS

WARRANTY

Our Company supports a worldwide network of Maintenance and Repair Centers. Contact your nearest Maintenance and Repair Centre for replacement parts, service, or information regarding the proper maintenance and repair of your cooking equipment.

In order to preserve the various agency safety certification (UL, NSF, ASME/Ntl. Bd., etc.), only factory-supplied replacement parts should be used. The use of other than factory supplied replacement parts will void warranty.

MANIFOLD ASSEMBLY

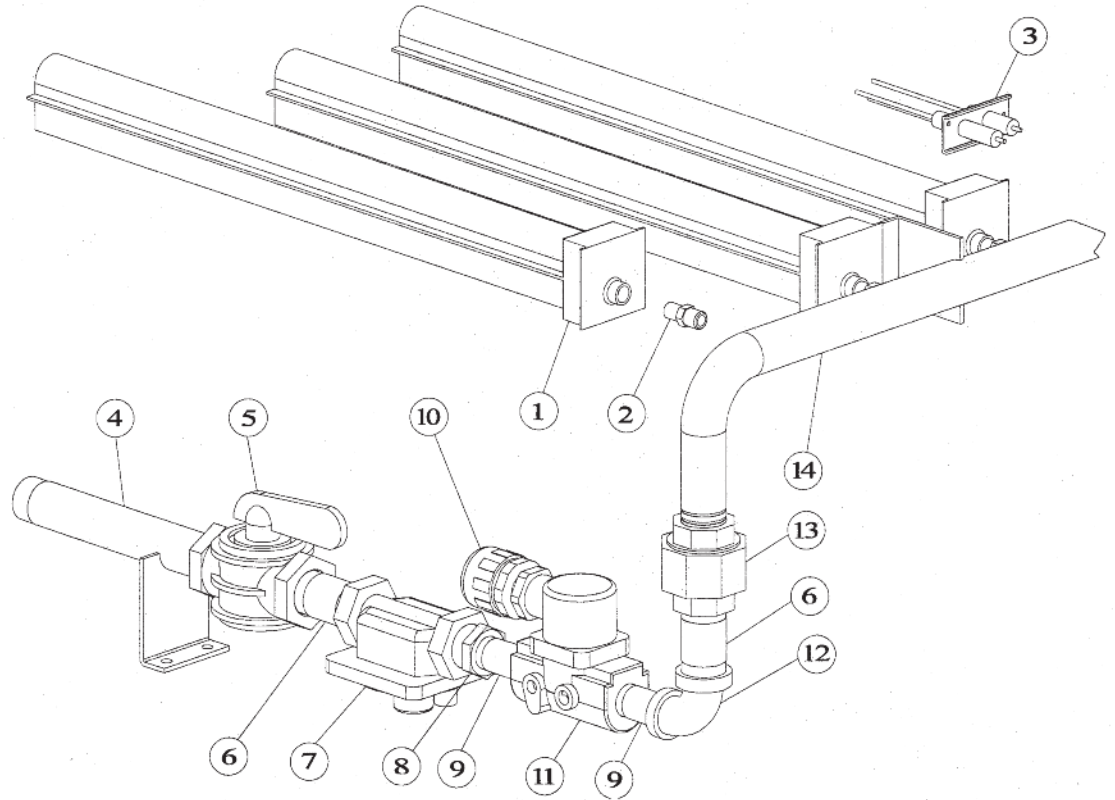

ITEM NO.	PART NO.	DESCRIPTION	QTY.
1	SK2373100	BURNER (NAT. GAS)	7 for 30 gal., 10 for 40 gal.
	KE02410	BURNER (LP GAS)	7 for 30 gal., 10 for 40 gal.
2	KE55277-1	ORIFICE, (NAT. GAS), 2000 FT	7 for 30 gal., 10 for 40 gal.
	KE55277-5	ORIFICE, (LP GAS), 2000 FT.	7 for 30 gal., 10 for 40 gal.
3	KE53437-1	SPARK ELECTRODE	1
4	SK2363599	NIPPLE PLATE ASSY	1
5	F01518-1	SHUT-OFF VALVE	1
6	N0640C2	NIPPLE 3/4" NPT	2
7	KE54618-2	GAS REGULATOR - NATURAL	1
	KE54618-1	GAS REGULATOR - LP	1
8	FI00336	NPT BUSHING 3/4" X 1/2"	1
9	N0440C2	NIPPLE 1/2" NPT X 2"	2
11	SK2345703	GAS SOLENOID, Domestic	1
	SK2345702	GAS SOLENOID, CE & Australia	1
12	FI00357	ELBOW 90° 3/4" X 1/2"	1
13	FI00073-1	UNION 3/4" NPT	1
14	SK2339799	MANIFOLD - 40 GAL.	1
	SK2339899	MANIFOLD - 30 GAL.	1

POWER TILT ASSEMBLY

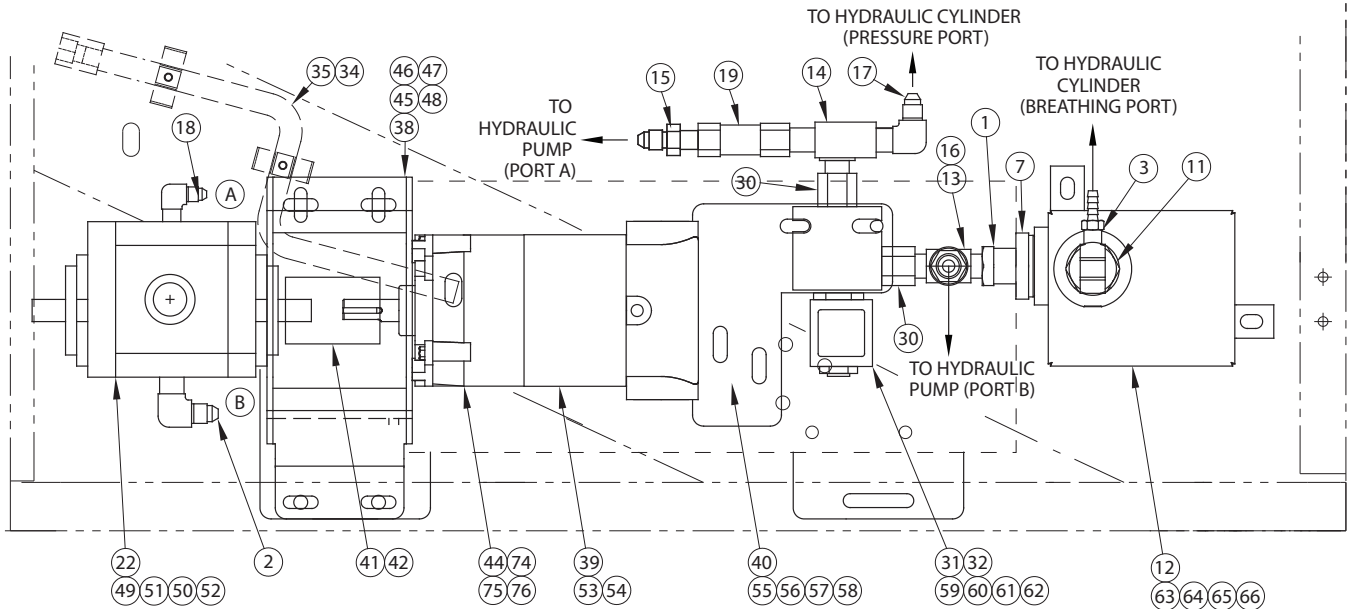

ITEM	PART #	DESCRIPTION	QTY.
1	FI00351	HEX BUSHING; 1/2 X 1/4	1
2	FI05059	ELBOW; STRAIGHT THREAD	1
3	FI05318-1	ELBOW HOSE BARB 90 BRASS	1
4	KE000523	HYDRAULIC JACK ASSY TR/F	1
5	KE53143	PLUG; 1/4-18 HYDRAULIC	1
6	KE55267	FLOW RESTRICTOR MT/TR	1
7	KE600452	STRAINER; OIL (MT-TR/F)	1
8	KE603728	COVER; CONTROL SWITCHES	1
9	M194	HYDRAULIC OIL; HD68-4L	1
10	SK2147401	FITTING; LIQUID TIGHT	1
11	SK2250700	PLUG MODIFD FI00285	1
12	SK2375699	OIL TANK ASSY MT/TR	1
13	SK2378900	TEE; 1/4 P (M/F/M)	1
14	SK2378901	TEE; 1/4 P (F/M/M)	1
15	SK2379000	ADAPTER; 1/4 P	1
16	SK2379001	ADAPTER; 1/4 P	1
17	SK2379100	ELBOW; 1/4-90D-	2
18	SK2379200	ELBOW; O'RING BOSS 90DEG	1
19	SK2379400	CHECK VALVE PARKER C400B	1
21	KE95586-2	LABEL; CLEVELAND/PT/TR	1
22	SK2378802	HYDRAULIC PUMP; TR/F	1
23	SK2379501	HYDRAULIC HOSE ASSY; 22	2
24	KE50581	BRIDGE RECTIFIER; #MB256	1
25	KE52936-9	FUSE; 15A/250V/MDA-15-R	1
26	SK1427305	CAPACITOR; 4700MF/63VDC	1
27	SK2282100	CAPACITOR; CLAMP #VR3	1
28	SK2343502	SWITCH; TILT SWITCH	1
29	KE601979	LIMIT SW ;TR- (UL APPV)	1
30	KE603895	HYDRAULIC HOSE ADAPTER	2
31	KE54834-17	SOLENOID VALVE	1
32	KE603873	SOLENOID VALVE CONNECTOR	1
33	KE003707	HYDRAULIC HOSE ASSY	1
34	KE003160	HANDLE MANUAL CRANK	1
35	SK2473800	CLIP; SMALL	2
36	F10	PAN QUAD SCR #8-32X3/8	2
37	KE54907-1	PLUG BUTTON	1
38	KE003705	MOTOR MOUNT BRACKET ASS'Y	1
39	KE603896	GEARMOTOR, DC	1
40	KE603898	SOLENOID MOUNTING PLATE	1
41	KE50582-5	COUPLING HUB 1/2 DIA.	2
42	KE50583-1	SPIDER	1
43	SK2147402	LIQUID TIGHT FITTING	1
44	KE603951	GEAR MOTOR COVER	1

ITEM	PART #	DESCRIPTION	QTY.
FASTENERS FOR THE MOTOR MOUNT BRACKET ASS'Y			
45	FA11260	HEX BOLTS S.S., 1/4-20UNC X 1"	4
46	FA30505-1	FLAT WASHER S.S., 1/4	8
47	FA31029	LOCK WASHER S.S., 1/4	4
48	FA21008	HEX NUT S.S., 1/4-20UNC	4
FASTENERS FOR THE HYDRAULIC PUMP			
49	FA11325	HEX BOLTS S.S., 15/16-18UNC X 1 1/4"	2
50	FA30505-5	FLAT WASHER S.S., 5/16	2
51	FA31030	LOCK WASHER S.S., 5/16	2
52	FA21024	HEX NUT S.S., 5/16-18UNC	2
FASTENERS FOR GEARMOTOR			
53	FA11148	10-32UNF X 3/4 PAN PHIL M/S 18-8 S.S.	4
54	FA32022	EXT. TOOTH LOCK WASHER S.S., #10	4
FASTENERS FOR SOLENOID MOUNTING PLATE			
55	FA11260	HEX BOLTS S.S., 1/4-20UNC X 1"	2
56	FA30505-1	FLAT WASHER S.S., 1/4	4
57	FA31029	LOCK WASHER S.S., 1/4	2
58	FA21008	HEX NUT S.S., 1/4-20UNC	2
FASTENERS FOR SOLENOID VALVE			
59	FA11509-4	HEX BOLTS S.S., 1/4-20UNC X 1 3/4"	2
60	FA30505-1	FLAT WASHER S.S., 1/4	4
61	FA31029	LOCK WASHER S.S., 1/4	2
62	FA21008	HEX NUT S.S., 1/4-20UNC	2
FASTENERS FOR TANK			
63	FA11148	10-32UNF X 3/4 PAN PHIL M/S 18-8 S.S.	1
64	FA32022	EXT. TOOTH LOCK WASHER S.S., #10	1
65	FA30505-2	FLAT WASHER S.S., #10	1
66	FA21006	HEX NUTS 18-8 S.S., #10-24UNC	1
FASTENERS FOR TILTING LIMIT SWITCH			
67	FA11148	10-32UNF X 3/4 PAN PHIL M/S 18-8 S.S.	2
70	FA30505-9	SAE FLAT WASHERS S.S., 1/4	2
71	FA31029	LOCK WASHERS 18.8, 1/4	2
73	FA11260	HEX BOLTS S.S., 1/4-20UNC X 1"	2
PAN WITH TD OPTION			
72	KE603877-1	LIMIT SWITCH MOUNTING BRACKET	1
PAN WITHOUT TD OPTION			
72	KE603877-2	LIMIT SWITCH MOUNTING BRACKET	1
TO ORDER COMPLETE ASSEMBLY:			
72	SK003706-1	FOR UNITS WITH TD OPTION	1
72	SK003706-3	FOR UNITS WITH OUT TD OPTION	1

ITEMS 4, 5, 6, 7, 8, 9, 10, 21, 23, 24, 25, 26, 27, 28, 29, 33, 36, 37, 43, 67, 70, 71, 72 & 73 NOT SHOWN

FAUCETS

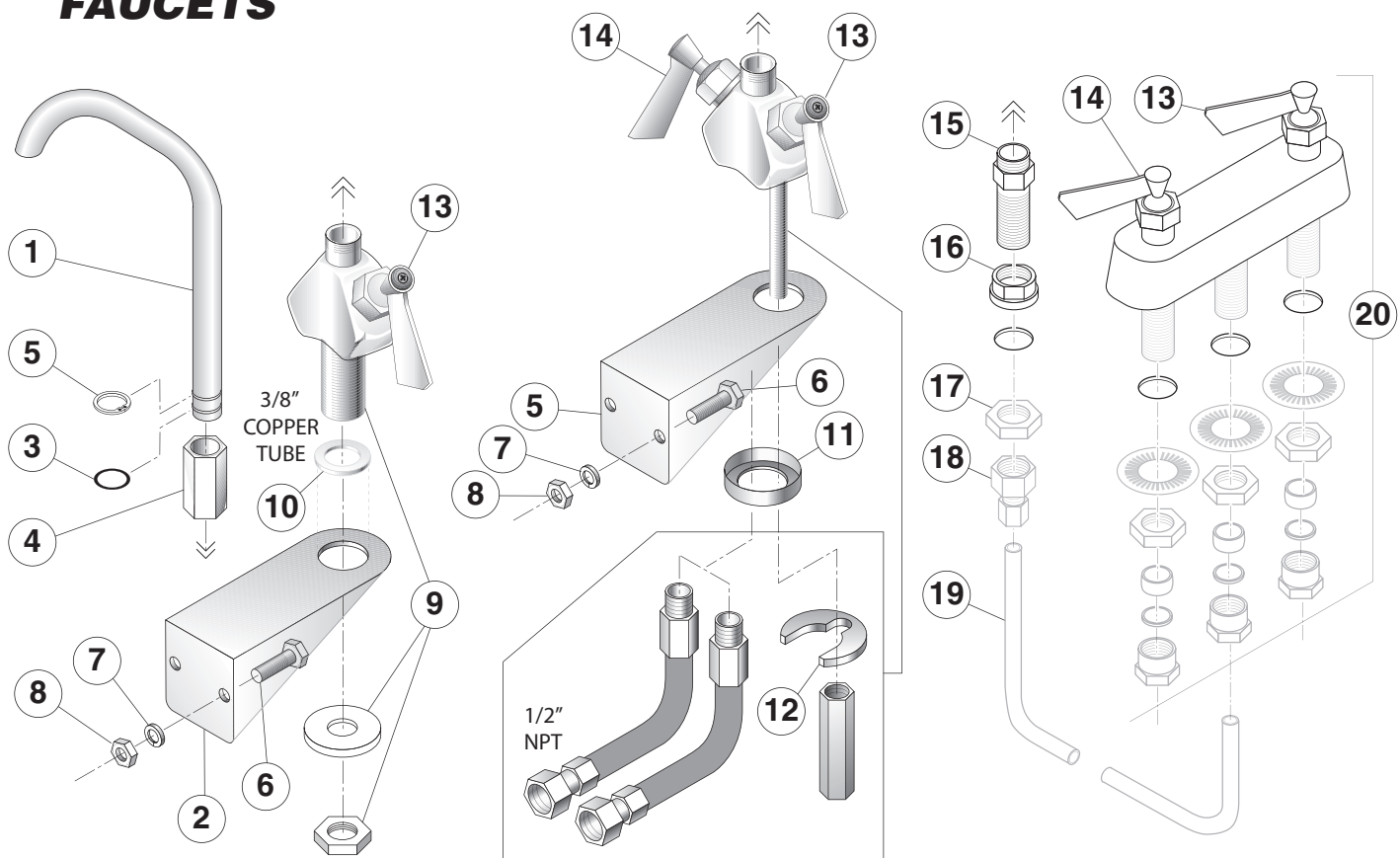

Common Parts

ITEM #	PART #	DESCRIPTION	QTY.
	SPK ____	SINGLE PANTRY FAUCET KIT , (includes items 1-10) see page 2 for ordering information	
	DPK ____	DOUBLE PANTRY FAUCET , (includes items 1-8 & 11) see page 2 for ordering information	
1.	KE50825- ____	SPOUT , see page 2 for ordering information	
2.	_____	FAUCET MOUNTING BRACKET , see page 2 for ordering information	1
3.	FA05002-19	"O" RING	1
4.	KE51736	LONG FAUCET NUT	1
5.	FA95007-10	RETAINING RING	1
6.	FA11258	HEX CAP SCREW	2
7.	FA31029	LOCK WASHER	2
8.	FA21008	HEX NUT	2
9.	KE51401	SINGLE PANTRY BODY (c/w item 13)	1
10.	KE50335	ADAPTER WASHER	1
11.	KE51403	DOUBLE PANTRY BODY (c/w item 13 & 14)	1
12.	SE50447	REPLACEMENT HORSESHOE WASHER	1
13.	SE50021	REPLACEMENT STEM ASSEMBLY, COLD WATER	1
14.	SE50020	REPLACEMENT STEM ASSEMBLY, HOT WATER	1
15.	SD50097	FLANGED NUT, 3/4" NPT, CHROME PLATED	1
16.	KE51585	FAUCET SPOUT FITTING	1
17.	SD50098	LOCKNUT, 3/4" NPT	1
18.	FI00266	COUPLING, 1/2" NPT	1
19.	SD50100	COPPER TUBE	1
20.	KE51899	REMOTE VALVE (c/w item 13 & 14)	1

FAUCETS

Models

	FAUCET KIT	BRACKET	SPOUT
KDT12/20 ON SD TABLE	SPK1 DPK1		KE50825-1
KDL60/80/100T KEL40/60/80/100T KET20 KGT,MKET, KDP60-100/T	SPK2 DPK2	KE54159 KE02071-1 (CP)	KE50825-2
KDL25/40T KEL25T,KDP25/40T	SPK3 DPK3	KE54159	KE50825-3
KDM60/T	SPK-KDM60 DPK-KDM60		KE50825-2
KDM25/40/T	SPK6 DPK6		KE50825-6
KDL40/60/80TSH KEL40/60TSH	SPK7 DPK7	KE54159	KE50825-7
KDT6 ON SD OR ST	SPK8 DPK8		KE50825-8
TKET, KET3/6/12	SPK9 DPK9	KE54159	KE50825-9
KDL125/150T KGL40/60/80T KGL40TSH	SPK10 DPK10	KE54159	KE50825-10
HAMKGL60/80/100T	SPK11 DPK11	KE54159	KE50825-11
KGL25T, T1	SPK13 DPK13	SK00395-1 KE02071-2 (CP)	KE50825-7
TR	SPK14 DPK14	SK2382300 SK2382400 (SPACER)	KE50825-6
SET10	DPK15 SPK15	SK2308800	KE50825-6
SET15	SPK16 DPK16	SK2302200	KE50825-6
HAMKGL60/80/100	DPK17 SKP17		KE50825-12
ALL STATIONARY KETTLES	DPK5 SPK5		KE50825-5

MANUAL TILT ASSEMBLY

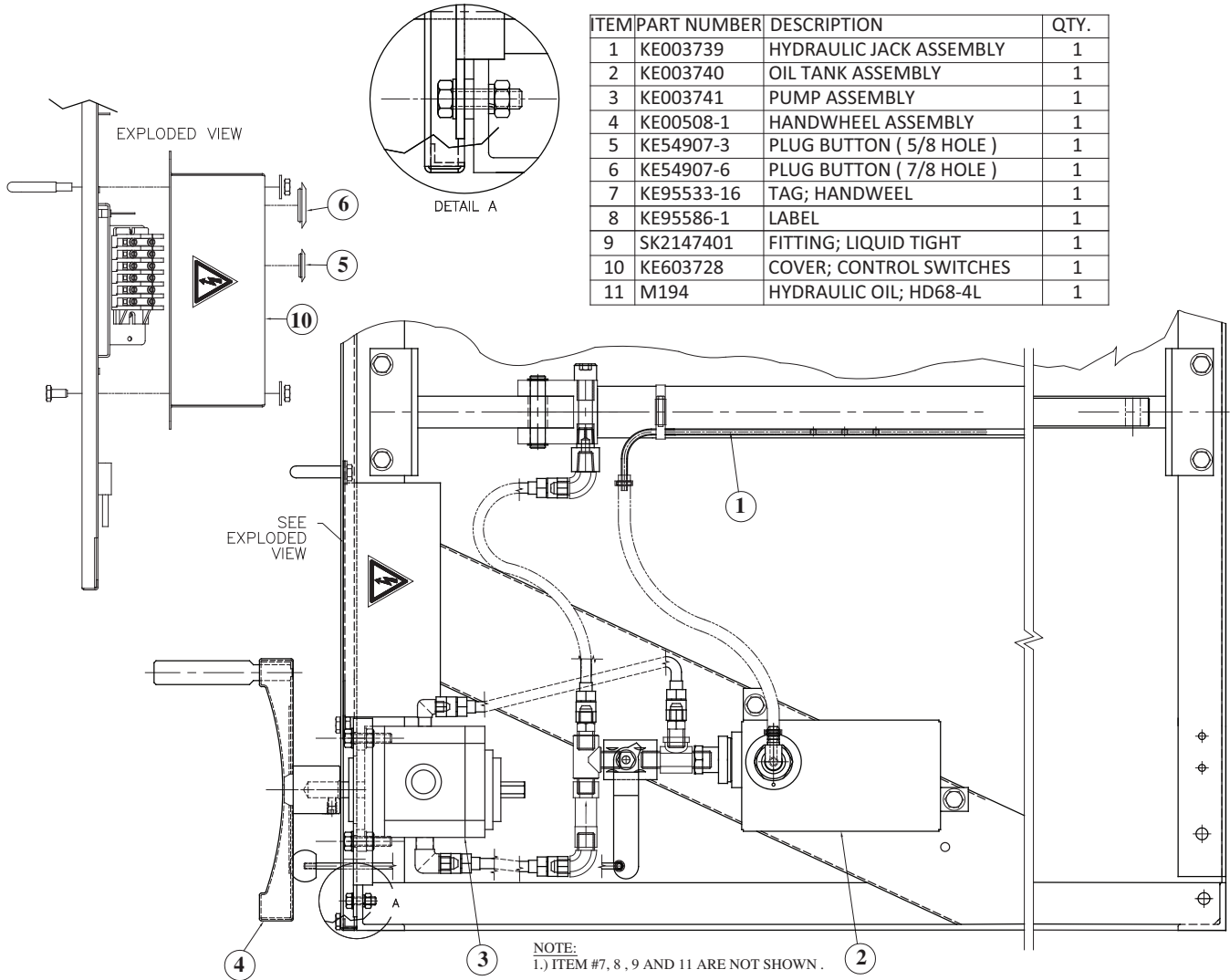

ITEM	PART NUMBER	DESCRIPTION	QTY.
1	KE003739	HYDRAULIC JACK ASSEMBLY	1
2	KE003740	OIL TANK ASSEMBLY	1
3	KE003741	PUMP ASSEMBLY	1
4	KE00508-1	HANDWHEEL ASSEMBLY	1
5	KE54907-3	PLUG BUTTON (5/8 HOLE)	1
6	KE54907-6	PLUG BUTTON (7/8 HOLE)	1
7	KE95533-16	TAG; HANDWEEL	1
8	KE95586-1	LABEL	1
9	SK2147401	FITTING; LIQUID TIGHT	1
10	KE603728	COVER; CONTROL SWITCHES	1
11	M194	HYDRAULIC OIL; HD68-4L	1

KE003746

HYDRAULIC JACK ASSEMBLY

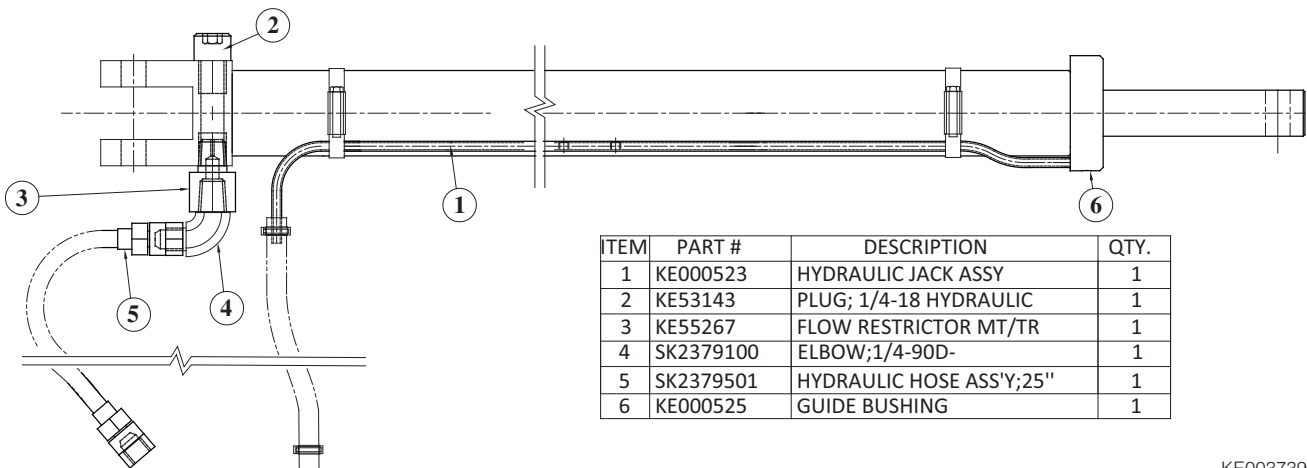

ITEM	PART #	DESCRIPTION	QTY.
1	KE000523	HYDRAULIC JACK ASSY	1
2	KE53143	PLUG; 1/4-18 HYDRAULIC	1
3	KE55267	FLOW RESTRICTOR MT/TR	1
4	SK2379100	ELBOW;1/4-90D-	1
5	SK2379501	HYDRAULIC HOSE ASS'Y;25"	1
6	KE000525	GUIDE BUSHING	1

KE003739

OIL TANK ASSEMBLY

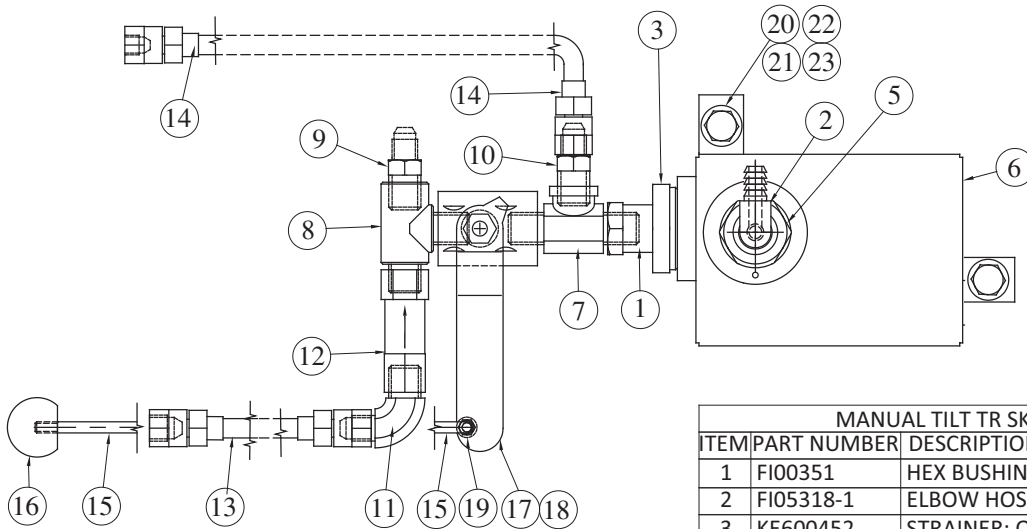

MANUAL TILT TR SKILLET ASSEMBLY			
ITEM	PART NUMBER	DESCRIPTION	QTY.
1	FI00351	HEX BUSHING;1/2 X 1/4	1
2	FI05318-1	ELBOW HOSE BARB 90 BRASS	1
3	KE600452	STRAINER; OIL (MT-TR/F)	1
5	SK2250700	PLUG MODIFD FI00285	1
6	SK2375699	OIL TANK ASSY MT/TR	1
7	SK2378900	TEE; 1/4 P (M/F/M)	1
8	SK2378901	TEE; 1/4 P (F/M/M)	1
9	SK2379000	ADAPTER; 1/4 P	1
10	SK2379001	ADAPTER; 1/4 P	1
11	SK2379100	ELBOW;1/4-90D-	1
12	SK2379400	CHECK VALVE PARKER C400B	1
13	SK2379500	HYDRAULIC HOSE ASS'Y;8"	1
14	SK2379600	HYDRAULIC HOSE ASS'Y.	1
15	SK2376200	LINK ROD	1
16	SK078279-1	BALL KNOB	1
17	SK2379301	BALL VALVE	1
18	SK2382700	VALVE RETURN SPRING	1
19	FA20504-3	LOCK NUT #10	1
20	FA11260	HEX BOLT S.S. 1/4-20 X 1	2
21	FA30505-1	FLAT WASHER S.S 1/4	2
22	FA31029	LOCK WASHER S.S 1/4	2
23	FA21008	HEX NUT S.S 1/4	2

KE003740

PUMP ASSEMBLY

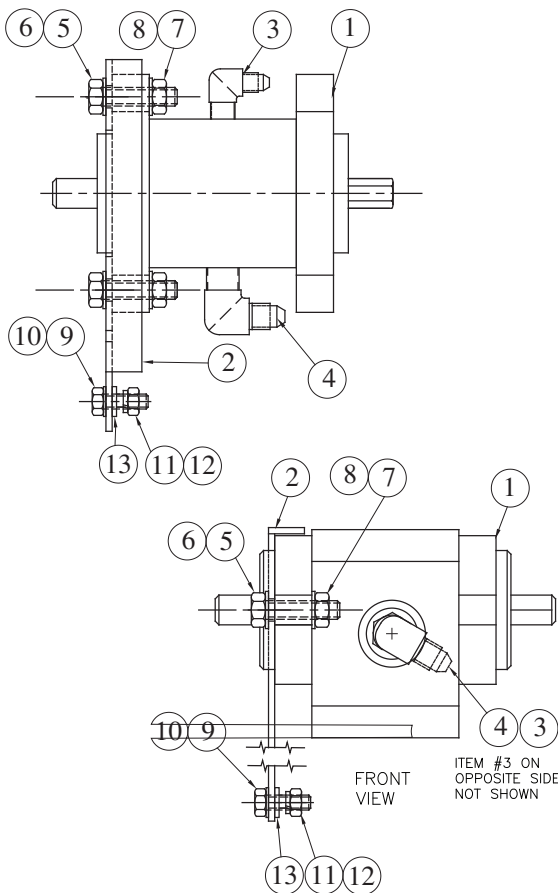

KE003741

ITEM	PART NUMBER	DESCRIPTION	QTY.
1	SK2378802	HYDRAULIC PUMP; TR/F	1
2	SK2376000	PUMP MOUNT BRACKET	1
3	FI05059	ELBOW; STRAIGHT THREAD	1
4	SK2379200	ELBOW;O'RING BOSS 90DEG	1
5	FA11325	HEX BOLT S.S. 5/16-18 X 1 1/4	2
6	FA30505-5	FLAT WASHER S.S 5/16	2
7	FA21024	HEX NUT S.S. 5/16-18	2
8	FA31030	SPLIT LOCKWASHER S.S 5/16	2
9	FA11260	HEX BOLT S.S. 1/4-20 X 1	3
10	FA30505-1	FLAT WASHER S.S 1/4	3
11	FA31029	LOCK WASHER S.S 1/4	3
12	FA21008	HEX NUT S.S 1/4	3
13	FA30504	FLAT WASHER 0.328 X 0.625	3

PANEL ASSEMBLY

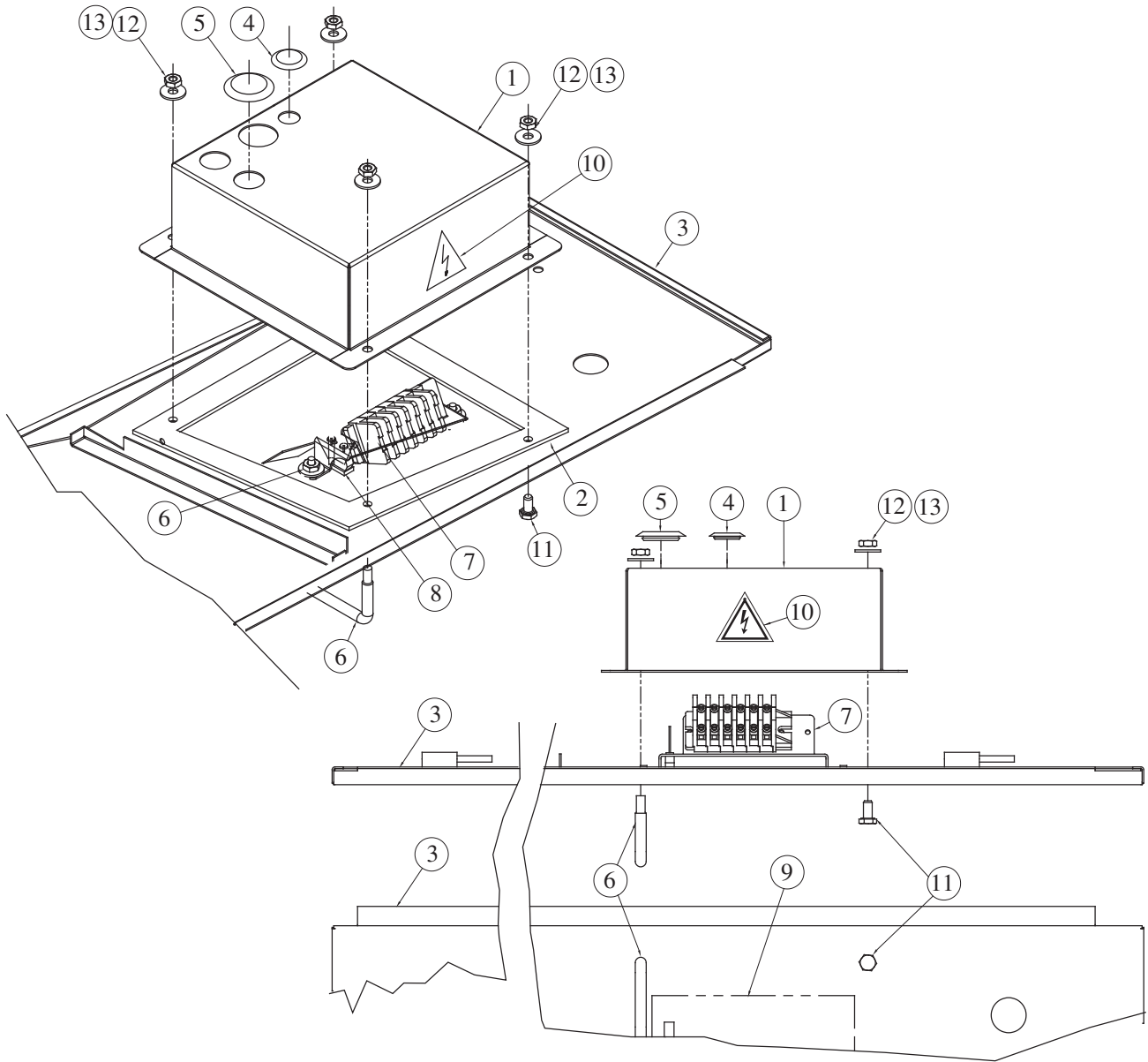

KE003742

KE003742-1 PANEL ASSEMBLY SGL-30-TR			
ITEM	PART NUMBER	DESCRIPTION	QTY.
1	KE603728	COVER; CONTROL SWITCHES	1
2	KE603729	GASKET	1
3	SK00383-4	CONTROL PANEL ASS'Y 30 GAL	1
4	KE54907-3	PLUG BUTTON (5/8 HOLE)	1
5	KE54907-6	PLUG BUTTON (7/8 HOLE)	1
6	KE601005	SWITCH GUARD	1
7	KE603726	TERMINAL BLOOCK BRACKET	1
8	SK50905-1	28V INDICATOR CLEAR LIGHT	1
9	KE95586-1	LABEL; TR SKILLETS	1
10	KE95497	LABEL; RISK OF EL. SHOCK	1
11	FA11260	HEX BOLT S.S. 1/4-20 X 1	2
12	FA30505-1	FLAT WASHER S.S 1/4	4
13	FA21008	HEX NUT S.S 1/4	4
14	FA20504-3	LOCK NUT #10	2

KE003742-2 PANEL ASSEMBLY SGL-40-TR			
ITEM	PART NUMBER	DESCRIPTION	QTY.
1	KE603728	COVER; CONTROL SWITCHES	1
2	KE603729	GASKET	1
3	SK00383-3	CONTROL PANEL ASS'Y 40 GAL	1
4	KE54907-3	PLUG BUTTON (5/8 HOLE)	1
5	KE54907-6	PLUG BUTTON (7/8 HOLE)	1
6	KE601005	SWITCH GUARD	1
7	KE603726	TERMINAL BLOOCK BRACKET	1
8	SK50905-1	28V INDICATOR CLEAR LIGHT	1
9	KE95586-1	LABEL; TR SKILLETS	1
10	KE95497	LABEL; RISK OF EL. SHOCK	1
11	FA11260	HEX BOLT S.S. 1/4-20 X 1	2
12	FA30505-1	FLAT WASHER S.S 1/4	4
13	FA21008	HEX NUT S.S 1/4	4
14	FA20504-3	LOCK NUT #10	2

CONTROL PANEL

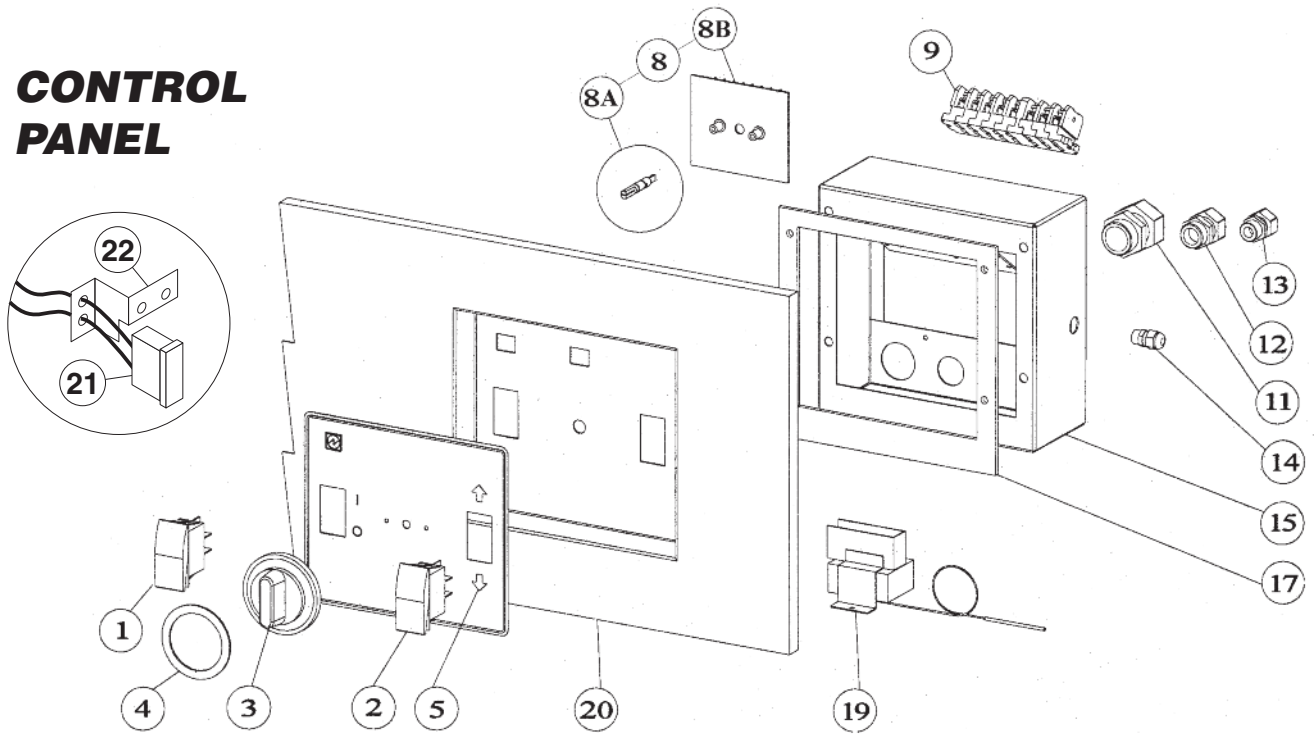

ITEM NO.	PART NO.	DESCRIPTION	QTY.
1	SK2474101	POWER SWITCH	1
2	SK2343502	TILT SWITCH (POWER TILT ONLY)	1
3	SK2138700	DIAL KNOB	1
4	SK2360701	DIAL INSERT °C	1
	SK2360700	DIAL INSERT °F	1
5	SKKE95586-1	LABEL, CLEVELAND, MANUAL TILT	1
	KE95586-2	LABEL, CLEVELAND, POWER TILT	1
8	SE00119	ELECTRONIC THERMOSTAT KIT (INCLUDES 8A & 8B)	1
8A	SK2142002	ELECTRONIC THERMOSTAT	1
8B	SK2498399	SHAFT ASSY.	1
9	SK50872-1	TERMINAL BLOCK	16
	SK50872-2	TERMINAL END	3
	KE603726	TERMINAL BLOCK BRACKET	1
11	SK2147403	LIQUID-TIGHT FITTING 5/8"	1
12	SK2147402	LIQUID-TIGHT FITTING 3/8"	1
13	SK2147401	LIQUID-TIGHT FITTING 5/16" (POWER TILT ONLY)	1
14	SK2147400	LIQUID-TIGHT FITTING 3/16"	1
15	KE603728	COVER, CONTROL SWITCHES	1
17	KE603729	NEOPRENE GASKET	1
19	KE55069-7	HIGH LIMIT	1
20	SK00383-1	CONTROL PANEL, POWER TILT, 40-TR	1
	SK00383-2	CONTROL PANEL, POWER TILT, 30-TR	
	SK00383-3	CONTROL PANEL, MANUAL TILT, 40-TR	1
	SK00383-4	CONTROL PANEL, MANUAL TILT, 30-TR	1
21	SK50905-2	INDICATOR LIGHT (ELECTRIC MODELS)	1
22	SK50903-1	BRACKET	1

THERMOSTAT KIT

SE00119

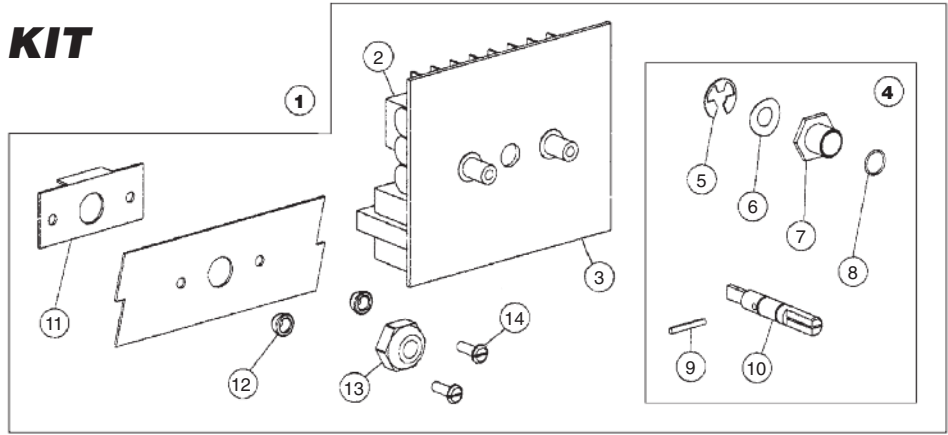

ITEM NO.	PART NO.	DESCRIPTION	QTY.
1.	SE00119	THERMOSTAT BOARD ASSEMBLY (INCLUDES 2 - 14)	1
2.	SK2142002	TEMPERATURE SENSOR BOARD	1
3.	SK2159300	INSULATOR, THERMOSTAT	1
4.	SK2498399	POTENTIOMETER SHAFT ASSEMBLY (INCLUDES 5-10)	1
5.	SK2167200	RETAINING RING, SP-NR #R1000-25	1
6.	SK2167100	WASHER, BOWED/SPRING	1
7.	SK2167300	PANEL BEARING	1
8.	SK2382800	RETAINING RING CLIP	1
9.	SK2167000	TENSION PIN	1
10.	SK2166800	POTENTIOMETER SHAFT	1
11.	SK2491500	STOP PLATE ASSY.	1
12.	KE55242-2	SEALER WASHER	2
13.	KE51005	ROTARY SHAFT SEAL	1
14.	FA11056	SCREW 6-32 X 1/8	2

PAN HINGE

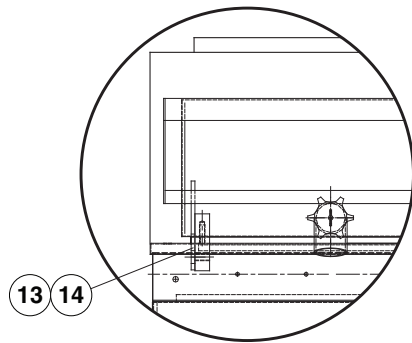

For units with TD Valve

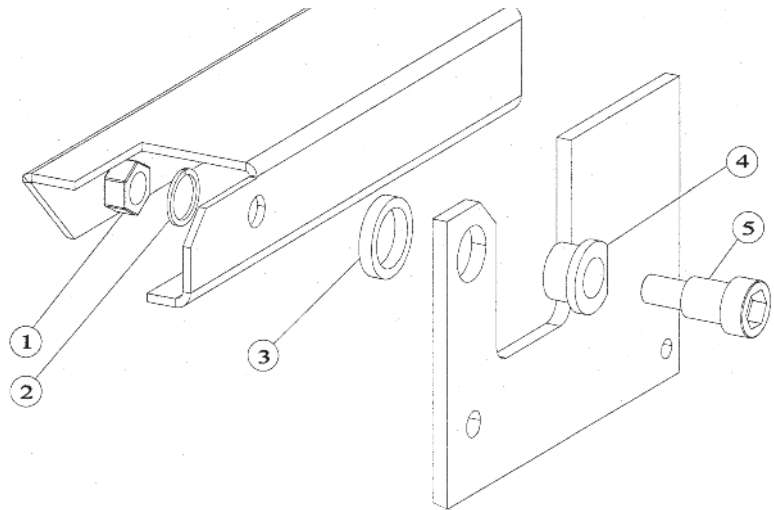

ITEM NO.	PART NO.	DESCRIPTION	QTY.
1	FA20032	LOCK NUT 1/2-13 S.S.	.2
2	FA30505-3	LOCK WASHER.	.2
3	SK078248-1	SPACER	.2
4	G02925-2	BUSHING	.2
5	FA15015	BOLT 1/2-13 X 3/4", for units without TD Valve	.2
13	FA15019-2	SHOULDER BOLT, 1/2-13 (303)	.2
14	SK50813	BEARING HINGE	.2

FRAME / LID ASSMEBLY

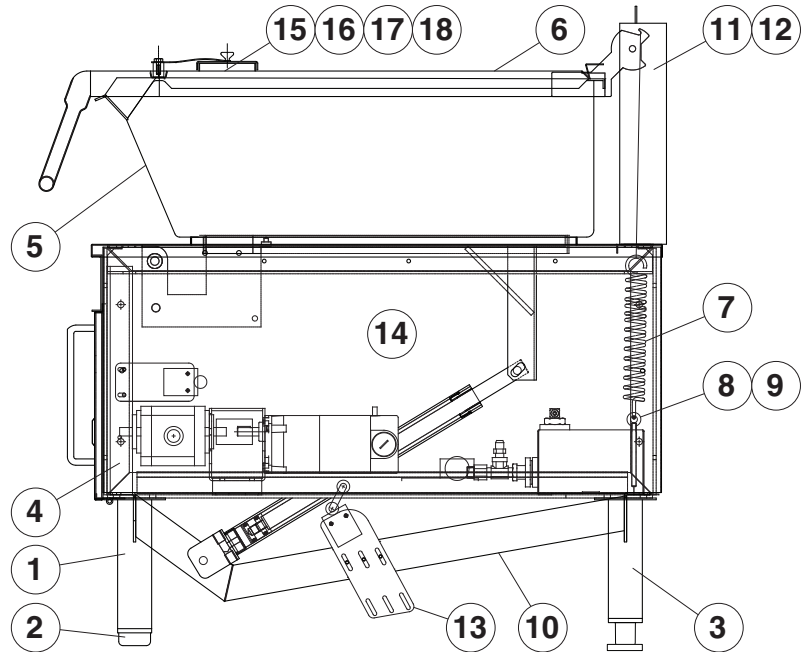

ITEM NO.	PART NO.	DESCRIPTION	QTY.
1.	SK2335499	LEG ASSEMBLY, FRONT	2
2.	SK078160-1	FEET, FRONT. for SGL	2
	SK078160-2	FEET, FRONT. for SGM	2
3.	SK00414-1	LEG ASSEMBLY, REAR	2
4.	SK2335199	FRAME WELDMENT, 30 GAL.	1
	SK2335099	FRAME WELDMENT, 40 GAL.	1
5.	SK00343-1	PAN ASSEMBLY, 30TR (no TD)	1
	SK00343-2	PAN ASSEMBLY, 30TR (with TD)	1
	SK00343-3	PAN ASSEMBLY, 30TR (Left Hand Lip)	1
	SK00342-1	PAN ASSEMBLY, 40TR (no TD)	1
	SK00342-2	PAN ASSEMBLY, 40TR (with TD)	1
	SK00342-3	PAN ASSEMBLY, 40TR (Left Hand Lip)	1
6.	SK24571-1	LID, 30 GAL.	1
	SK24571-2	LID, 40 GAL.	1
7.	SK2452300	SPRING	2
8.	KE003686	HOOK WELDMENT	2
9.	SK23724-1	HOOK	2
10.	SK2337499	ACTUATOR MOUNTING BRACKET	1
	SK00352	ACTUATOR MOUNTING BRACKET, for units with TD	1
11.	KE003605-1	BACKGUARD ASSEMBLY, 30 GAL.	1
	KE003605	BACKGUARD ASSEMBLY, 40 GAL.	1
12.	SK2389300	BACKGUARD BACK, 30 GAL.	1
	SK2389301	BACKGUARD BACK, 40 GAL.	1
13.	KE002206	LIMIT SWITCH BRACKET	1
	KE002199	LIMIT SWITCH BRACKET, for units with TD	1
14.	SK2336800	SIDE PANEL, SEL/SGL	2
	SK2336801	SIDE PANEL, SEM/SGM	2
15.	SK00054	VENT COVER ASSEMBLY	1
16.	SK2211200	EXTENSION VENT COVER	1
17.	FA11255	HEX BOLT, 1/4-20X3/8	1
18.	SK50179	WASHER	1

ELECTRICAL BOX -

MANUAL
TILT

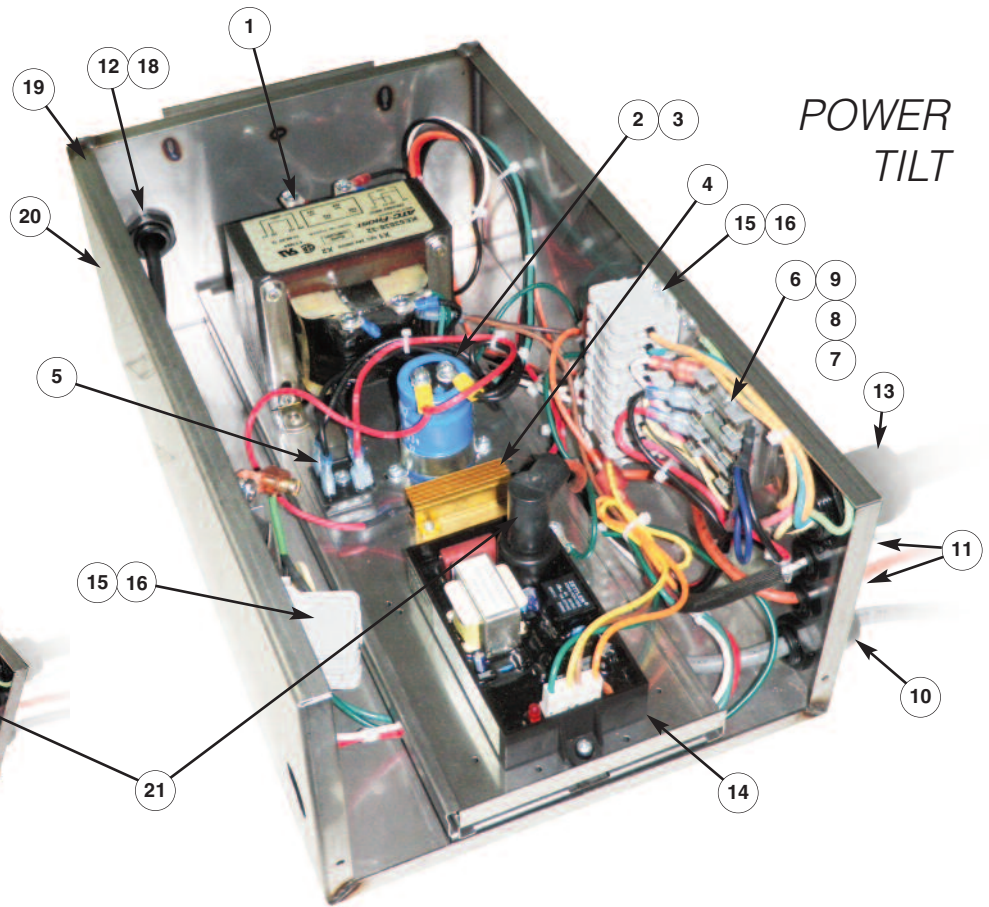

POWER
TILT

ITEM NO.	PART NO.	DESCRIPTION	QTY.
1	KE53838-32	TRANSFORMER - POWER TILT - 110-120V/60	1
	KE53838-31	TRANSFORMER - POWER TILT - 208-240/60	1
	KE53838-30	TRANSFORMER - POWER TILT - 208-240/50	1
	KE53838-25	TRANSFORMER - HAND TILT - 110-120/60	1
	KE53838-18	TRANSFORMER - HAND TILT - 208-240	1
2	SK1427305	CAPACITOR	1
3	SK2282100	CAPICITOR CLAMP	1
4	SK1426600	RESISTOR	1
5	KE50581	RECTIFIER, POWER TILT ONLY	1
6	SK2320702	FUSE HOLDER	1
7	KE52936-7	FUSE 2.5A MDL 115V POWER TILT	1
	KE52936-10	FUSE 1.5A MDL 208/240V POWER TILT	1
	KE52936-13	FUSE 1A AGC 115V HAND TILT	1
	KE52936-11	FUSE .5A AGC 208/240V HAND TILT	1
8	KE52936-9	FUSE 15A MDA POWER TILT ONLY	1
9	KE52936-8	FUSE 1.25A AGC	1
10	SK2147403	LIQUID-TIGHT FITTING	1
11	SK2147400	LIQUID-TIGHT FITTING	2
12	SK2147401	LIQUID-TIGHT FITTING	1
13	SK2361500	LIQUID-TIGHT FITTING	1
14	KE603774-1	IGNITION MODULE, Domestic	1
	KE603774-2	IGNITION MODULE, CE & Australia	1
15	SK50872-1	TERMINAL BLOCK - SECTION	18
16	SK50872-2	TERMINAL END	1
19	SK2383300	COVER GASKET	1
20	2343699	SERVICE BOX ASSY.	1
21	SE00222	IGNITION CABLE	1

BURNER BOX ASSEMBLY

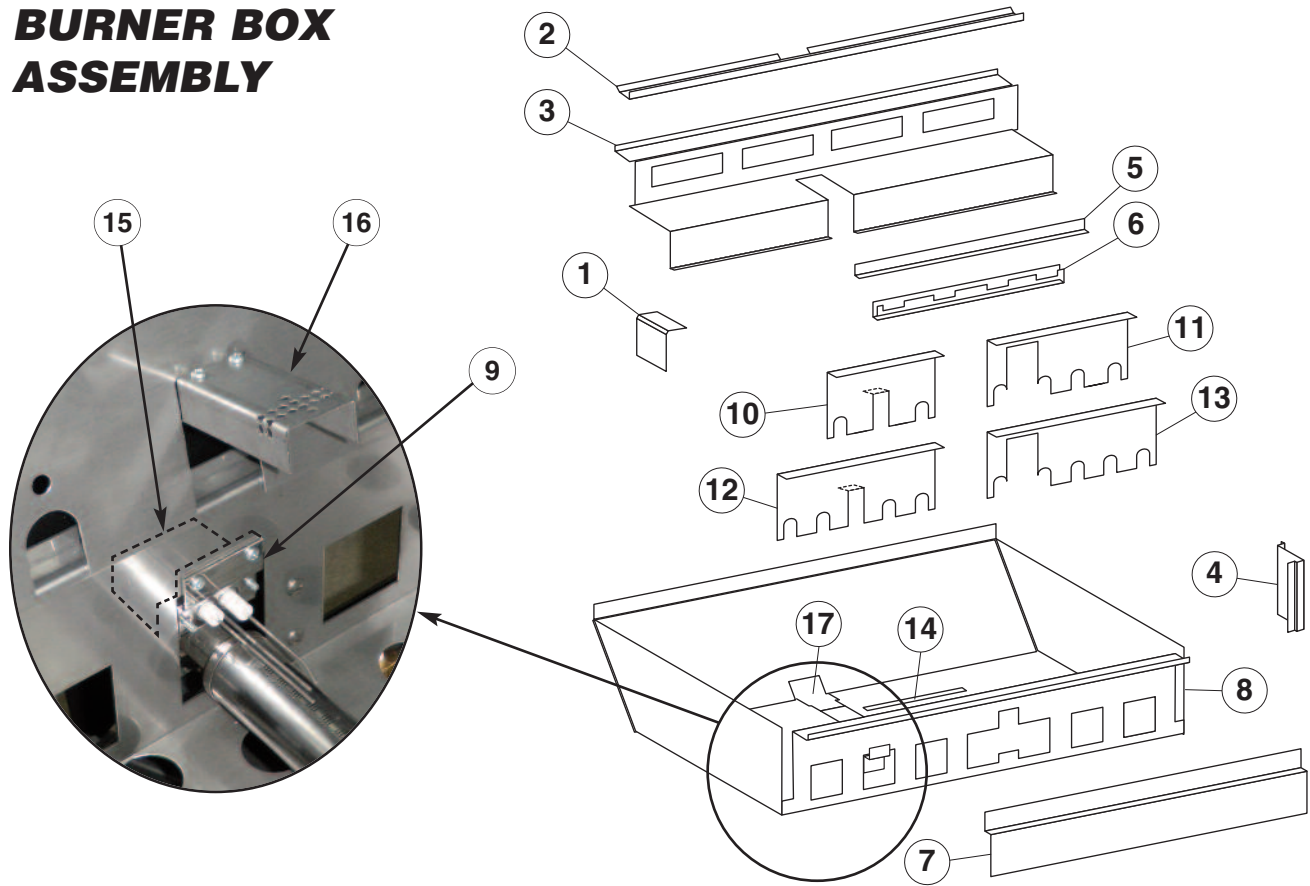





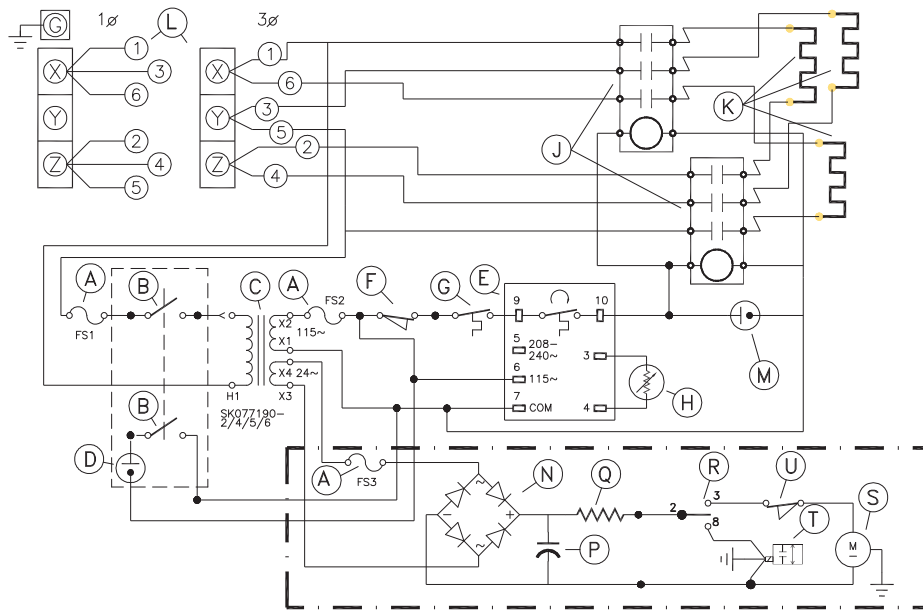

ITEM NO.	PART NO.	DESCRIPTION	QTY.
1	SK2359300	BACK TOP MOUNTING BRACKET	2
2	SK2360101	REAR COMBUSTION SEAL - 40 GAL.	1
	SK2360100	REAR COMBUSTION SEAL - 30 GAL.	1
3	SK2342499	BURNER REST ASSEMBLY - 40 GAL.	1
	SK2342399	BURNER REST - ASSEMBLY 30 GAL.	1
4	SK071497-2-9	INSIDE HINGE COVER	2
5	KE603745	BURNER BOX STIFFENER - 40 GAL.	1
	KE603748	BURNER BOX STIFFENER - 30 GAL.	1
6	SK2445300	SECONDARY BURNER REST R/H - 30 GAL.	1
	SK2445400	SECONDARY BURNER REST L/H - 30 GAL.	1
	SK2445200	SECONDARY BURNER REST R/H - 40 GAL.	1
	SK2445201	SECONDARY BURNER REST L/H - 40 GAL.	1
7	SK2347800	FRONT SHIELD - 40 GAL.	1
	SK2347900	FRONT SHIELD - 30 GAL.	1
8	SK2342200	BURNER PAN - 40 GAL.	1
	SK2342100	BURNER PAN - 30 GAL.	1
9	SK2373900	IGNITOR MOUNTING BRACKET	1
10	SK50890	BURNER SHIELD R/H - 40 GAL.	1
11	SK50891	BURNER SHIELD L/H - 40 GAL.	1
12	SK50892	BURNER SHIELD R/H - 30 GAL.	1
13	SK50893	BURNER SHIELD L/H - 30 GAL.	1
14	SK2342600	BURNER TIE DOWN - 30 GAL, LEFT	1
	SK2342601	BURNER TIE DOWN - 30 GAL, RIGHT	1
	SK2342602	BURNER TIE DOWN - 40 GAL	2
15	SK2373901	IGNITOR COVER	1
16	SK2380200	IGNITOR PROTECTOR	1
17	SK2337500	TRAY SEAL	1

WIRING DIAGRAM

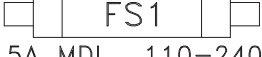

- | | |
|----------------------------|---|
| A- FUSE | K- ELEMENT |
| B- POWER SWITCH | L- TERMINAL BLOCK |
| C- TRANSFORMER | M- PILOT-YELLOW |
| D- PILOT-RED | N- RECTIFIER |
| E- ELECTRONIC THERMOSTAT | P- CAPACITOR |
| F- INTERRUPTER SWITCH | Q- RESISTOR |
| G- HIGH LIMIT SWITCH | R- TILT CONTROL |
| H- RTD SENSOR | S- MOTOR |
| J- CONTACTOR | T- DUMPING VALVE |
| | U- LIMIT SWITCH |
| | - · - POWER TILT ONLY |
| A- FUSIBLE | K- ELEMENT |
| B- COMMUTATEUR DE POUVOIR | L- BLOC D'ALIMENTATION |
| C- TRANSFORMATEUR | M- VEILLEUSE-JAUNE |
| D- VEILLEUSE-ROUGE | N- RECTIFICATEUR |
| E- THERMOSTAT ÉLECTRONIQUE | P- CONDENSATEUR |
| F- INTERRUPTEUR DE POUVOIR | Q- RÉSTANCE |
| G- COMMUTATEUR DE SECURITE | R- COMMUTATEUR DIRECTIONNEL |
| H- CAPTEUR DE RTD | S- MOTEUR |
| J- CONTACTEUR | T- DECHARGER SOUPAPE |
| | U- COMMUTATEUR DE LIMITE |
| | - · - INCLINER D'ALIMENTATION SEULEMENT |

CAUTION: REPLACE WITH SAME TYPE FUSES	
ATTENTION: REPLACER PAR UN FUSIBLE DU MÊME TYPE	
<p>MODELS/MODÈLES POWER TILT/BASCULANT AUTO</p> <div style="text-align: center;">  FS3 15A MDA </div> <div style="text-align: center;">  FS2 1A AGC </div> <div style="text-align: center;">  FS1 1.5A MDL 110-240V MODELS ONLY MODÈLES SEULEMENT </div>	<p>MODELS/MODÈLES HAND TILT/BASCULANT MANUEL</p> <div style="text-align: center;">  FS3 NOT USED/INUTILISÉ </div> <div style="text-align: center;">  FS2 1A AGC </div> <div style="text-align: center;">  FS1 .5A AGC 110-240V MODELS ONLY MODÈLES SEULEMENT </div>

208/240/380/415/480V F30,40E-L,MR/SEL,M-30,40-TR SK90123-2G

WIRING DIAGRAM

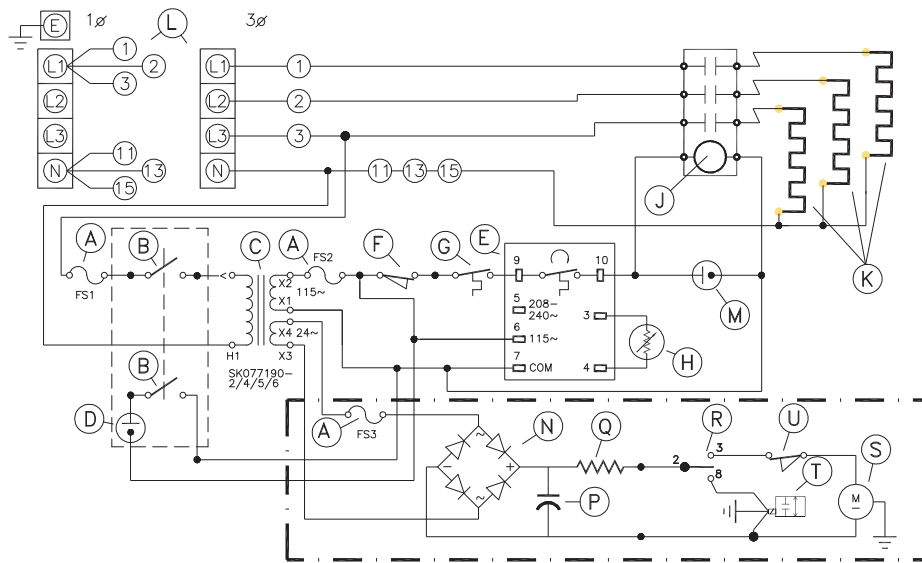

- A- FUSE
- B- POWER SWITCH
- C- TRANSFORMER
- D- PILOT-RED
- E- ELECTRONIC THERMOSTAT
- F- INTERRUPTER SWITCH
- G- HIGH LIMIT SWITCH
- H- RTD SENSOR
- J- CONTACTOR

- K- ELEMENT
- L- TERMINAL BLOCK
- M- PILOT-YELLOW
- N- RECTIFIER
- P- CAPACITOR
- Q- RESISTOR
- R- TILT CONTROL
- S- MOTOR
- T- DUMPING VALVE
- U- LIMIT SWITCH





- · - POWER TILT ONLY

- A- FUSIBLE
- B- COMMUTEUR DE POUVOIR
- C- TRANSFORMATEUR
- D- VEILLEUSE-ROUGE
- E- THERMOSTAT ÉLECTRONIQUE
- F- INTERRUPTEUR DE POUVOIR
- G- COMMUTEUR DE SECURITE
- H- CAPTEUR DE RTD
- J- CONTACTEUR

- K- ELEMENT
- L- BLOC D'ALIMENTATION
- M- VEILLEUSE-JAUNE
- N- RECTIFICATEUR
- P- CONDENSATEUR
- Q- RÉSISTANCE
- R- COMMUTEUR DIRECTIONNEL
- S- MOTEUR
- T- DECHARGER SOUPAPE
- U- COMMUTEUR DE LIMITE

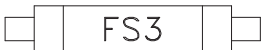
- · - INCLINER D'ALIMENTATION SEULEMENT

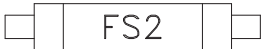
CAUTION: REPLACE WITH SAME TYPE FUSES
ATTENTION: REPLACER PAR UN FUSIBLE DU MÊME TYPE

MODELS/MODELES POWER TILT/BASCULANT AUTO	MODELS/MODELES HAND TILT/BASCULANT MANUEL
 FS3 15A MDA	 FS3 NOT USED/INUTILISÉ
 FS2 1A AGC	 FS2 1A AGC
 FS1 1.5A MDL 110-240V MODELS ONLY MODÈLES SEULEMENT	 FS1 .5A AGC 110-240V MODELS ONLY MODÈLES SEULEMENT

220/380,240/415V 3N~

F30,40E-L,MR/SEL,M-30,40-TR

SK90123-1G

Every new piece of Welbilt Foodservice equipment comes with KitchenCare® and you choose the level of service that meets your operational needs from one restaurant to multiple locations

StarCare – Warranty & lifetime service, certified OEM parts, global parts inventory, performance audited

ExtraCare — CareCode, 24/7 Support, online/mobile product information

LifeCare – Install & equipment orientation, planned maintenance, KitchenConnect™, MenuConnect®

Talk with KitchenCare® • 1-844-724-CARE • www.mtwkitchencare.com



To learn how Welbilt Foodservice and its leading brands can equip you, visit our global web site at www.welbilt.com, then discover the regional or local resources available to you.