



Combi Oven

OES 6.10 mini easyTouch

Installation manual UL, USA - Original, ENG

FOR THE INSTALLER, OPERATOR, RESPONSIBLE OWNER

FOR YOUR SAFETY

Do not store or use gasoline or other flammable vapors or liquids in the vicinity of this or any other unit.



WARNING

Improper installation, adjustment, alteration, service or maintenance can cause property damage, injury and death. Read the installation, operating and maintenance instructions thoroughly before installing or servicing this equipment.



WARNING

To reduce the risk of electric shock, do not remove or open cover. No user serviceable parts inside. Refer servicing to qualified personnel. Disconnect power supply before servicing.



WARNING

Disconnect power at the main external power switch before servicing or repairing a combi oven.

IMPORTANT

ALL SERVICE MUST BE PERFORMED BY A QUALIFIED CONVOTHERM AUTHORIZED TECHNICIAN.

KEEP AREA FREE AND CLEAR OF COMBUSTIBLES.

Installation

- Installation of this unit must be done by a licensed professional when installed in the Commonwealth of Massachusetts.
- The wiring diagram is located on the inner part of the side panel.

Customer documentation

- The customer documentation is part of the combi oven.
- Keep the customer documentation manuals handy at all times so that you can look up any required information.
- Keep the customer documentation manuals for the entire life of the unit.
- Carefully read the installation manual, the operating manual, and the operating instructions before using, handling, and working on this unit.
- If you transfer the combi oven to a new owner, make sure to give the new owner the customer documentation manuals as well.

Table of Contents

| | | |
|----------|--|-----------|
| 1 | General | 7 |
| 1.1 | Environmental Protection | 7 |
| 1.2 | Identifying Your Combi Oven | 8 |
| 1.3 | Customer Documentation Structure | 9 |
| 1.4 | Safety Information That Must Be Read without Exception | 10 |
| 1.5 | About This Installation Manual | 11 |
| 2 | Configuration and Functions | 13 |
| 2.1 | The Combi Oven's Configuration and Functions | 13 |
| 2.2 | Control Panel Layout and Functions | 15 |
| 3 | For Your Safety | 16 |
| 3.1 | Basic Safety Instructions | 16 |
| 3.2 | Your Combi Oven's Intended Use | 18 |
| 3.3 | Warning Labels on the Combi Oven | 20 |
| 3.4 | Hazards and Safety Measures When Moving the Unit | 22 |
| 3.5 | Hazards and Safety Measures During Setup | 23 |
| 3.6 | Hazards and Safety Measures During Installation | 25 |
| 3.7 | Hazards and Safety Measures When Putting the Unit into Operation | 27 |
| 3.8 | Hazards and Safety Measures When Removing the Unit from Service | 30 |
| 3.9 | Safety Devices | 33 |
| 3.10 | Staff and Work Area Requirements | 35 |
| 3.11 | Personal protective equipment | 37 |
| 4 | Transportation | 38 |
| 4.1 | Working Safely During Transportation | 38 |
| 4.2 | Transporting the unit to the installation location | 39 |
| 5 | Setup | 40 |
| 5.1 | Working Safely During Setup | 40 |
| 5.2 | Adjacent Systems | 41 |
| 5.3 | Installation location requirements | 42 |
| 5.4 | Unpacking | 46 |
| 5.5 | Setting up the unit on a work table | 48 |
| 5.6 | Setting Up the Unit on a Stand | 49 |
| 6 | Installation | 51 |
| 6.1 | Electrical installation | 51 |
| 6.1.1 | Working Safely When Installing the Electrical Installation | 51 |
| 6.1.2 | Planning the Electrical Installation | 52 |
| 6.1.3 | Performing the Electrical Installation | 53 |
| 6.2 | Water connection | 54 |
| 6.2.1 | Working Safely When Setting Up the Water Connection | 54 |
| 6.2.2 | Water supply | 55 |
| 6.2.3 | Water drain | 57 |
| 6.3 | ConvoClean System Installation | 59 |
| 6.3.1 | Working Safely When Installing the ConvoClean System | 59 |
| 6.3.2 | Components of Fully Automatic Oven Cleaning System | 60 |
| 6.3.3 | Connecting the Fully Automatic Cleaning System | 61 |

| | | |
|----------|---|-----------|
| 7 | Placing into operation | 62 |
| 7.1 | Working Safely When Putting the Unit Into Operation | 62 |
| 7.2 | Procedure for Placing the Unit into Operation | 65 |
| 8 | Removing from Service and Disposal | 67 |
| 8.1 | Working Safely When Removing the Unit from Service | 67 |
| 8.2 | Removing from Service and Disposal | 69 |
| 9 | Technical Data and Connection Drawing | 70 |
| 9.1 | Technical data | 70 |
| 9.2 | Connection drawing | 73 |

1 General

Purpose of this section

This section provides information on how to identify your combi oven and how to use this manual.

1.1 Environmental Protection

Policy statement

Our customers' expectations, the legal regulations and standards we have to follow, and our company's reputation are what drives the quality and service behind all our products.

Our environmental management policy is not only designed to ensure that we are always in full compliance with all environmental laws and regulations, but also reflects our commitment to the environment and to continuously improving our performance in this field.

In order to ensure that we meet all of our environmental goals while maintaining the high quality of our products, and that things stay this way, we have developed a quality and environmental management system.

This system meets the requirements set forth in ISO 9001:2008 and ISO 14001:2004.

Environmental protection measures

The following measures apply to this product:

- Uses fully compostable packing products
- Uses RoHS-compliant products
- Complies with the REACH regulation
- Shipping boxes are reused
- Recommends and uses biodegradable cleaning agents
- E-waste recycling
- Environmentally friendly disposal of old units

Join us in our commitment to protecting the environment!

1.2 Identifying Your Combi Oven

Nameplate location

The nameplate is found on the left side of the combi oven.

Nameplate layout and structure

The nameplate makes it easy to identify your unit. The nameplate has the following layout:

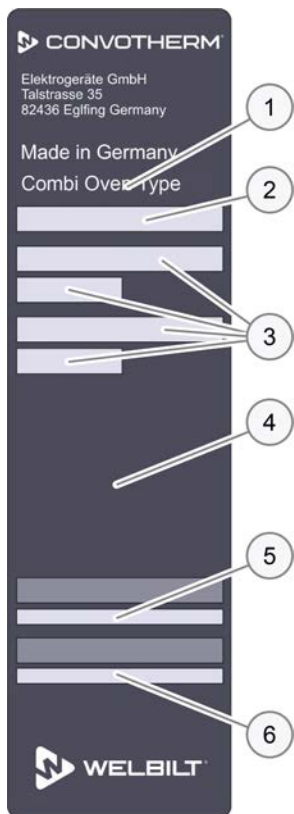

| No. | Designation |
|-----|---|
| 1 | Unit name Combi Oven |
| 2 | Trade name Letters: _____ Meaning: _____ OES _____ Electrical units with water injection xx.yy numbers _____ Unit size mini _____ Series |
| 3 | Electrical specifications |
| 4 | Unit tests |
| 5 | Serial number |
| 6 | Item number |

1.3 Customer Documentation Structure

Customer documentation parts

The customer documentation for the combi oven is made up of the following:

- Installation manual (this manual)
- Operating manual
- Operating instructions for easyStart mode
- Help pages integrated into the software (excerpt from the operating manual)

Customer Documentation Structure

The following table outlines how the customer documentation is structured:

| Subject | Description | Please refer to |
|-----------------------------------|--|--|
| Transportation | Transporting the combi oven | Installation manual |
| Setup | <ul style="list-style-type: none"> ▪ Setup options ▪ Correctly setting up the combi oven | (intended for trained qualified personnel; see Staff Requirements) |
| Installation | <ul style="list-style-type: none"> ▪ Electrical connection ▪ Water connection ▪ Installing the ConvoClean fully automatic cleaning system | |
| Placing into operation | Combi oven initial startup | |
| Operation | <ul style="list-style-type: none"> ▪ User interface explanation ▪ Work sequences and steps | Operating manual |
| Cleaning | <ul style="list-style-type: none"> ▪ Cleaning schedule ▪ Cleaning programs and tasks | (intended for briefed staff and trained qualified staff; see Staff Requirements) |
| Maintenance | <ul style="list-style-type: none"> ▪ Maintenance Schedule ▪ limited maintenance work | |
| Removing from service | Removing the combi oven from service | Installation manual |
| Technical data | <ul style="list-style-type: none"> ▪ Shelf options ▪ max. loading weight | Operating manual |
| | All the technical data for the combi oven | Installation manual |
| Scale drawings, connection points | All the scale drawings and connection points for the combi oven | Installation manual |
| Checklists | Installation checklists | |

1.4 Safety Information That Must Be Read without Exception

Safety information found in the documentation for the customer

The most important safety information for the combi oven is essentially found in the installation manual and operating manual.

The installation manual provides safety information for the transportation, setup, installation, placing-into-operation, and removal-from-service tasks it describes.

The operating manual provides safety information for the cooking, cleaning, and maintenance tasks it describes.

When using the operating instructions, the operating manual or installation manual should always be consulted in order to obtain the relevant safety information. When performing activities that go beyond simply using the software, the safety information in the operating manual and installation manual must always be observed.

Parts of this document that must be read without exception

Failure to take the information in this document into account may result in death, injury, or property damage.

In order to ensure their safety and the safety of others, everyone working with/on the combi oven must read and understand the following parts of this document before starting any work:

- The 'For Your Safety' section; please refer to For Your Safety on page 16
- The sections describing the work that will be carried out



Danger symbol

| Danger symbol | Meaning |
|---|---|
|  | Used to warn of potential injury. Observe all the precautionary statements following this symbol in order to avoid injury or death. |



Precautionary statements

The precautionary statements in this manual are categorized using the following hazard levels:

| Hazard level | Consequences | Likelihood |
|--|--------------------------------------|------------|
|  DANGER | Death / severe injury (irreversible) | Imminent |
|  WARNING | Death / severe injury (irreversible) | Potential |
|  CAUTION | Minor injury (reversible) | Potential |
| NOTICE | Property damage | Potential |

1.5 About This Installation Manual

Purpose

The purpose of this installation manual is to provide everyone working with/on the combi oven with the information they will need to transport, set up, install, and place the unit into operation safely and correctly.

Target groups

This installation manual is intended for the following target groups:

| Name of target group | Tasks |
|----------------------|---|
| Mover | Transporting the unit within the facilities |
| Service technician | <ul style="list-style-type: none"> ▪ Setting up the unit ▪ Installing and uninstalling the water connection ▪ Installing the ConvoClean fully automatic cleaning system ▪ Placing the unit into operation and removing it from service ▪ Briefing the user |
| Electrician | Installing and uninstalling electrical connections |

Installation manual outline

The following table describes the contents and goals for the various sections in this manual:

| Contents | Purpose |
|--|--|
| General | <ul style="list-style-type: none"> ▪ Helps identify your combi oven ▪ Explains how to use this installation manual |
| Configuration and Functions | <ul style="list-style-type: none"> ▪ Describes the combi oven's intended use ▪ Explains the combi oven's functions and describes where its components are located |
| For Your Safety | Describes all the risks and hazards posed by the combi oven, as well as appropriate instructions on how to prevent and/or counter them Read this section carefully! |
| Transportation | <ul style="list-style-type: none"> ▪ Provides basic unit dimensions ▪ Provides information on the requirements concerning the installation location ▪ Explains how to transport the unit to its installation location |
| Setup | <ul style="list-style-type: none"> ▪ Explains how to unpack the unit and goes over the included equipment and parts ▪ Explains how to set up the combi oven |
| Installation | Explains how to install: <ul style="list-style-type: none"> ▪ Electrical connection ▪ Water connection ▪ ConvoClean fully automatic cleaning system |
| Placing into operation | Explains how to put the unit into operation |
| Removing from Service, Disposal | <ul style="list-style-type: none"> ▪ Explains how to remove the unit from service ▪ Provides disposal information |
| Technical data | Contains technical specifications |
| Scale drawings and connection diagrams | Contains scale drawings and connection diagrams |

Decimal mark used

In order to ensure that all numbers can be properly understood internationally, a decimal point is always used.

2 Configuration and Functions

Purpose of this section

This section describes the combi oven's configuration and explains its functions.

2.1 The Combi Oven's Configuration and Functions

Combi oven's configuration

The following figure illustrates the combi oven:

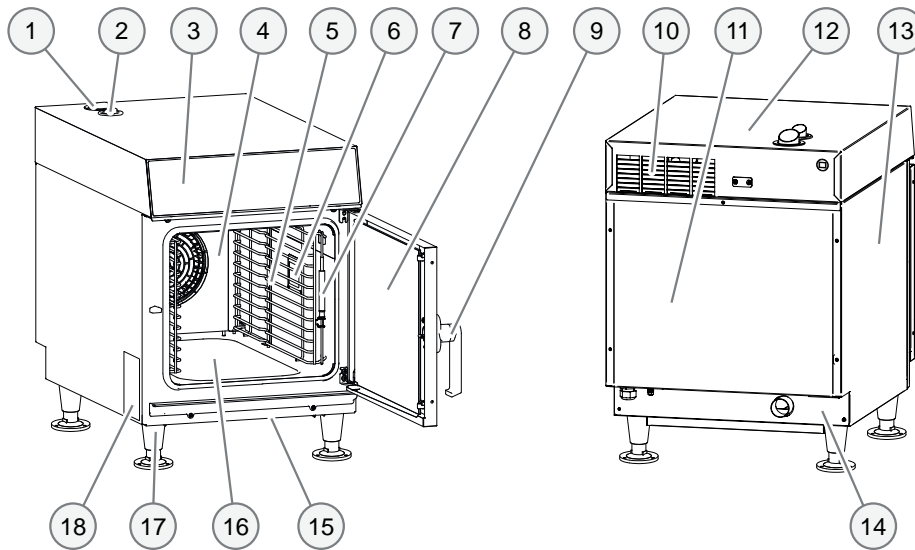

The combi oven's parts and what they do

Following is a description of what the combi oven's parts do:

| No. | Designation | Function |
|-----|--------------------------------|---|
| 1 | Ventilation port | Draws in ambient air in order to remove moisture from the oven cavity |
| 2 | Air vent | Lets steam escape |
| 3 | Control panel | Used to control the combi oven |
| 4 | Suction panel | Used to distribute heat within the oven |
| 5 | Rack | Used to hold standard-size bakeware |
| 6 | Oven light | Illuminates the oven cavity |
| 7 | Core temperature probe | Used to measure the food's core temperature |
| 8 | Unit door | Seals the oven cavity |
| 9 | Door handle | <ul style="list-style-type: none"> ▪ Used to open and close the unit door ▪ Cracked-open position for safely opening the combi oven |
| 10 | Vents | Used for ventilation purposes |
| 11 | Rear panel | Covers the combi oven's wiring compartment |
| 12 | Top enclosure | Covers the combi oven's control electronics |
| 13 | Outer case | Used to cover the inside of the unit |
| 14 | Connection angle bracket | Used to cover the connection area |
| 15 | Opening between the front feet | Used for ventilation purposes |

2 Configuration and Functions

| No. | Designation | Function |
|-----|-------------|--|
| 16 | Oven cavity | Is where food is placed while it is being cooked |
| 17 | Unit feet | Used to set up and level the unit |
| 18 | Nameplate | Used to identify the combi oven |

Material

The combi oven's inner and outer parts are made of stainless steel.

2.2 Control Panel Layout and Functions

Control panel layout

The figure below shows the control panel:

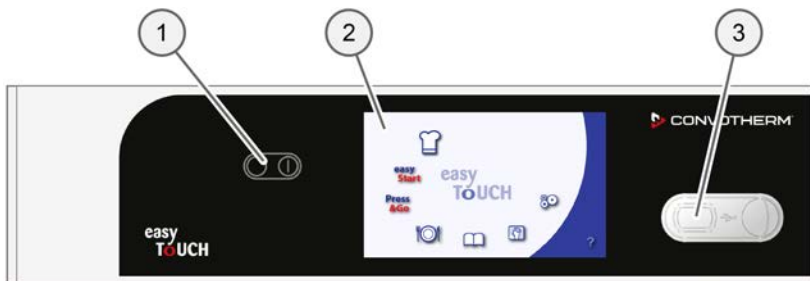

Control panel parts

Following is an explanation of what the control panel's parts do:

| No. | Designation | Function |
|-----|-------------|---|
| 1 | Main switch | Used to turn the combi oven on and off |
| 2 | Touchscreen | Central combi oven controls <ul style="list-style-type: none">▪ Used by touching the icons on the touchscreen▪ Status indicators |
| 3 | USB port | Used to connect external devices |

3 For Your Safety

Purpose of this section

The purpose of this section is to provide you with all the information you will need in order to safely work with/on the combi oven without putting yourself and others at risk.

Read this section very carefully!

3.1 Basic Safety Instructions

Purpose of these instructions

The purpose of these instructions is to ensure that everyone working with and on the combi oven will be fully aware of all the risks, hazards, and safety requirements involved and will observe the warnings in the operating manual and on the combi oven. Failure to follow these instructions may result in death, injury, or property damage.

Customer documentation manuals

Follow the instructions below:

- Fully read the 'For Your Safety' section, as well as the section that applies to the way you will be interacting with the combi oven.
- Keep the customer documentation manuals handy at all times so that you can look up any required information.
- If you transfer the combi oven to a new owner, make sure to give the new owner the customer documentation manuals as well.

Basic rules for installation

The unit must be installed in compliance with all national and state laws and regulations, with all applicable local requirements and regulations set forth by the relevant local utility companies and authorities, and with all other relevant regulations and standards.

These include, but are not limited to:

- The National Electrical Code, ANSI/NFPA 70 (current edition)
- The Canadian Electrical Code, CSA C22.2
- The Food Code and Food Service Sanitation Manual published by the Food and Drug Administration (FDA) (current editions)
- Latest edition of the International Plumbing Code published by the International Code Council (ICC) or the Uniform Plumbing Code published by the International Association of Plumbing and Mechanical Officials (IAPMO)
- The standards published by the National Sanitation Foundation (NSF)
- All local fire protection and occupational health and safety regulations

Working with/on the combi oven

Follow the instructions below:

- Only people who meet all the requirements specified in this operating manual should be allowed to use and otherwise work with/on the combi oven.
- Only use the combi oven for its intended use as described in this manual. Never, under any circumstance, use the combi oven for other purposes, even if they seem obvious.
- Observe all the safety measures specified in this operating manual and on the combi oven. This applies especially to wearing the required personal protective equipment.
- Make sure to always stay in the specified work areas when working with/on the combi oven.
- Do not make any alterations to the combi oven. This includes removing components and adding components that have not been expressly approved. Above all, however, make sure not to disable any safety devices or guards.

For more information...

Related subjects

| | |
|--|----|
| ▷ Your Combi Oven's Intended Use | 18 |
| ▷ Warning Labels on the Combi Oven | 20 |
| ▷ Hazards and Safety Measures When Moving the Unit | 22 |
| ▷ Hazards and Safety Measures During Setup | 23 |
| ▷ Hazards and Safety Measures During Installation | 25 |
| ▷ Hazards and Safety Measures When Putting the Unit into Operation | 27 |
| ▷ Hazards and Safety Measures When Removing the Unit from Service | 30 |
| ▷ Safety Devices | 33 |

3.2 Your Combi Oven's Intended Use

The combi oven's intended use

- The combi oven has been designed and built exclusively for cooking a variety of food in standard-size bakeware (steam table pans, sheet pans, etc.). Steam, convection, and combi-steam (steam superheated without pressure) are used for this purpose.
- The bakeware can be made of stainless steel, ceramic, plastic, aluminum, enameled steel, or glass. Glass bakeware must not be damaged.
- The combi oven is intended exclusively for professional commercial use.

Ventilation

The combi oven is a commercial combination oven with integral systems for limiting the emission of grease laden air.

This unit is UL category KNLZ listed for ventless operation. Allows operators to expand into new non-traditional outlets. Local codes prevail as stated in NFPA 96-1994 regulations.

The combi oven may need a hood to satisfy state and local codes. Check your local codes for requirements.

Limitations on use

The combi oven should not be used to heat up the following materials:

- Dry powders or granular products
- Readily flammable substances or objects with a flashpoint lower than 518°F, such as readily flammable oils, fats, and plastics
- Food in sealed cans

Staff requirements

- The combi oven must be run and installed exclusively by staff meeting the specified requirements. For the corresponding training and qualifications requirements, please refer to 'Staff and Work Area Requirements' on page 35.
- All staff must be familiar with the risks, hazards, and rules involved in handling heavy loads.

Requirements concerning the combi oven's functional capability

- Do not operate the combi oven unless it has been properly transported, set up, installed, and placed into operation as indicated in the installation manual and the person responsible for placing it into operation has confirmed this.
- The combi oven should only be used if all safety devices and guards are present, working properly, and correctly locked in place.
- All manufacturer specifications concerning how to run and service the combi oven must be observed.
- The load placed inside the combi oven must never exceed the maximum permissible loading weight; please refer to 'Technical Data' on page 70.

Requirements concerning the combi oven's surroundings

Required combi oven surroundings

- Ambient temperature between 40°F and 95°F
- No toxic or potentially explosive atmospheres
- Do not use or store gasoline or other flammable vapors, gases, or liquids in the vicinity of a combi oven
- Dry kitchen floor in order to reduce the risk of accidents occurring

Required installation location characteristics

- NO fire alarms or sprinkler system directly above the unit
- NO flammable materials, gases, or liquids above, on, under, or close to the unit

Limitations on use

- When used outdoors, the unit must be protected from rain and wind
- Do NOT shift or move the unit during operation

Prerequisites for cleaning

- Only use the cleaning agents approved by the manufacturer.
- Do NOT use a pressure washer to clean the unit.
- Do NOT use a water jet to clean the outside of the unit. Do not use a water jet for anything other than cleaning the oven cavity.
- Do NOT use bases or acids to clean the combi oven and make sure it is not exposed to acid fumes. The only exception is when the oven cavity and the boiler are descaled by an authorized service company following the manufacturer's instructions.

3.3 Warning Labels on the Combi Oven



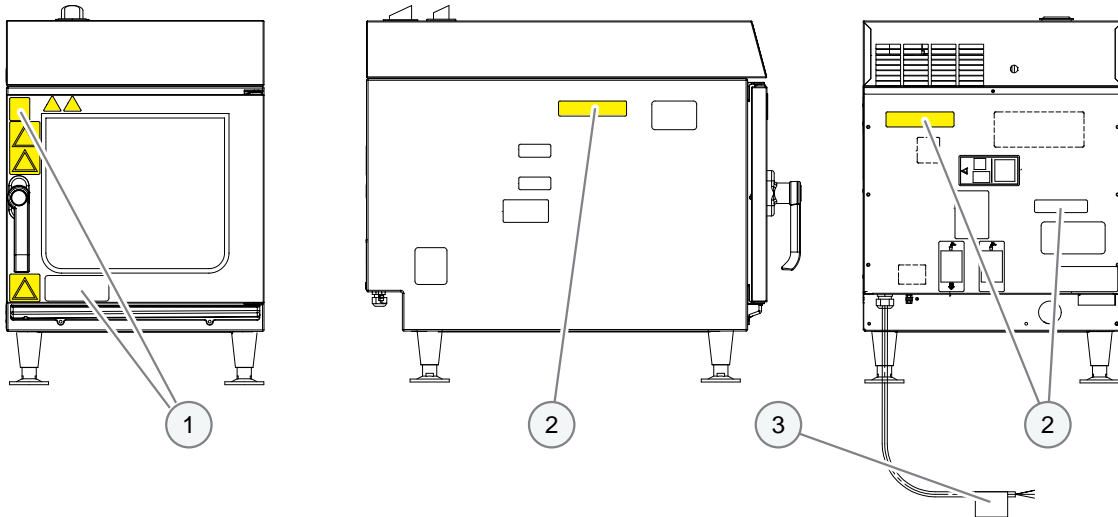

Warning label locations

The warning labels are found at the following locations on the combi oven:



Warning labels on unit door

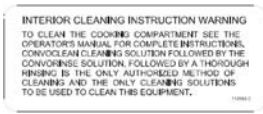

The following warning labels (1) are located on the unit door:

| Warning | Description |
|---|---|
|  | <p>Hot food, hot bakeware, and hot liquid warning</p> <p>Hot food and hot bakeware will pose a burn hazard if the bakeware falls off the shelf levels or if food slides off bakeware that is being held in an inclined position. This hazard will be particularly acute in the case of shelf levels located above the operator's field of view.</p> <p>Risk of scalding when liquid food is spilled. This hazard exists when liquids, or food that becomes liquefied during cooking, are placed on the upper shelf levels. Do not use shelf levels located above your field of view for liquids or food that will become liquefied.</p> |
|  | <p>Hot steam warning</p> <p>There is a risk of scalding posed by the hot steam coming out when the unit door is opened.</p> |
|  | <p>Caustic cleaning agent warning</p> <p>Skin, eye, and respiratory tract irritation hazard posed as a result of contact with cleaning agents, as well as their vapors, if the unit door is opened during fully automatic cleaning (ConvoClean system).</p> |
|  | <p>Only if using a moving base</p> <p>Combi oven tip-over hazard warning</p> <p>There is a risk of the combi oven toppling over when being moved. Exercise extreme caution when moving the combi oven.</p> |
|  | <p>Only if using a moving base</p> <p>Unit hookup damage and disconnection warning</p> <p>There is a risk of the unit's hookups being damaged or disconnected when the combi oven is moved. Exercise extreme caution when moving the combi oven and take the connections' length into account. Every time after moving it, secure the combi oven so that it cannot roll away by accident.</p> |

| Warning | Description |
|---|--|
|  | <p>CAUTION Surface(s) and Handle(s) may be hot.</p> <p>ATTENTION Surface(s) et poignée(s) chaudes</p> |
|  | <p>INTERIOR CLEANING INSTRUCTION WARNING</p> <p>To clean the cooking compartment see the operator's manual for complete instructions. ConvoClean cleaning solutions followed by the ConvoRinse solution. Followed by a thorough rinsing is the only authorized method of cleaning and the only cleaning solutions to be used to clean this equipment.</p> |

Warning labels on combi oven case

The following warning labels (2) are located on the combi oven's case:

| Warning | Description |
|---|--|
|  | <p>WARNING</p> <p>To reduce the risk of electric shock, do not remove or open cover. No user serviceable parts inside. Refer servicing to qualified personnel. Disconnect power supply before servicing.</p> |
|  | <p>AVERTISSEMENT</p> <p>Afin de réduire le risque d'électrocution, ne pas retirer ou ouvrir le capot. Aucune pièce réparable ne se trouve à l'intérieur. Confier le dépannage à du personnel qualifié. Débrancher l'alimentation électrique avant réparation.</p> |
|  | <p>CAUTION</p> <p>Before commencing plumbing installation refer to installation instruction furnished with unit. DO NOT INSTALL a SHUTOFF ON DRAIN OUTLET</p> |

Warning labels on power cord

The following warning labels (3) are located along the power cord:

| Warning | Description |
|---|---|
|  | <p>WARNING</p> <p>Risk of Fire. Use only a UL listed grounding type attachment plug rated for:</p> <ul style="list-style-type: none"> 208-240 V, 30 AMP Minimum, 3 PH, 4 Wire 208-240 V, 50 AMP Minimum, 3 PH, 4 Wire <p>The plug is to be selected and installed only by qualified service personnel or electricians.</p> |

3.4 Hazards and Safety Measures When Moving the Unit

Safety hazard: moving heavy loads

When moving or transporting the unit, keep the following hazards in mind and take the actions required in order to eliminate and/or minimize these hazards:

| Risk / hazard | Where and in which situations will the risk/hazard exist? | What to do | Safety device |
|--|---|---|---------------|
| Risk of injury due to excessive exertion | Whenever moving the unit | <ul style="list-style-type: none"> ▪ Use appropriate lifting equipment ▪ Do not lift or carry too much weight! ▪ Wear the required personal protective equipment | None |

Safety hazard: mechanical unit components

When moving or transporting the unit, keep the following hazards in mind and take the actions required in order to eliminate and/or minimize these hazards:

| Risk / hazard | Where and in which situations will the risk/hazard exist? | What to do | Safety device |
|--|---|---|---------------|
| Crush hazard for all body parts if the unit falls down | Whenever moving the unit | <ul style="list-style-type: none"> ▪ Use appropriate transportation equipment ▪ Transport equipment slowly and carefully and secure it in such a way that it cannot tip over ▪ Keep the unit's center of gravity in mind ▪ Avoid bumping into objects | None |
| Crush hazard for all body parts if the unit falls down or topples over | When setting the unit down on the surface on which it will be resting | Observe all the requirements concerning the supporting surface at all times while setting up the unit. Please refer to Installation Location Requirements on page 42 | None |

3.5 Hazards and Safety Measures During Setup

Safety hazard: moving heavy loads

When setting up the unit, keep the following hazards in mind and take the actions required in order to eliminate and/or minimize these hazards:

| Risk / hazard | Where and in which situations will the risk/hazard exist? | What to do | Safety device |
|--|---|---|---------------|
| Risk of injury due to excessive exertion | Whenever moving the unit | <ul style="list-style-type: none"> ▪ Use appropriate lifting equipment when placing the unit on a work table or equipment stand or in a stacking kit ▪ Make sure that a sufficient number of people help correct the unit's position; do not lift or carry too much weight during the process! ▪ Comply with all occupational health and safety regulations that apply at the installation location ▪ Wear the required personal protective equipment | None |

Safety hazard: mechanical unit components

When setting up the unit, keep the following hazards in mind and take the actions required in order to eliminate and/or minimize these hazards:

| Risk / hazard | Where and in which situations will the risk/hazard exist? | What to do | Safety device |
|---|--|--|--|
| Crush hazard for all body parts if the unit falls down | When lifting the unit | <ul style="list-style-type: none"> ▪ Keep the unit's center of gravity in mind ▪ Avoid bumping into objects | None |
| Crush hazard posed by a loss of unit stability if the unit is set up in a stacking kit or on an equipment stand | <ul style="list-style-type: none"> ▪ When setting up the unit on an equipment stand ▪ When setting up the unit in a stacking kit ▪ If the top is subjected to a heavy uneven load | <ul style="list-style-type: none"> ▪ Do not, under any circumstance, subject the units to additional loads (on the open unit door, for example) ▪ Always set up the bottom unit in the stacking kit first ▪ Before placing the units in a stacking kit with casters, lock the casters' wheels ▪ Make sure that the devices are properly set up inside the stacking kit | Brake and swivel lock when using a stacking kit with casters |
| Crush hazard for all body parts if the unit falls down or topples over | When setting up the unit on the surface on which it will be resting | Observe all the requirements concerning the supporting surface at all times while setting up the unit. Please refer to Installation Location Requirements on page 42 | None |
| Cut hazard posed by sharp edges | Whenever handling sheet metal parts | <ul style="list-style-type: none"> ▪ Exercise caution when performing these activities ▪ Wear the required personal protective equipment as indicated in the relevant safety instructions | None |

3.6 Hazards and Safety Measures During Installation

Safety hazard: electricity

When installing the unit, keep the following hazards in mind and take the actions required in order to eliminate and/or minimize these hazards:

| Risk / hazard | Where and in which situations will the risk/hazard exist? | What to do | Safety device |
|--|--|--|----------------|
| Risk of electric shock posed by live parts | <ul style="list-style-type: none"> ▪ Under covers ▪ Under the operating panel ▪ All along the power cord | <ul style="list-style-type: none"> ▪ Work on the unit's electrical components should be performed exclusively by a qualified electrician from an authorized service company ▪ Work professionally | Covers |
| | | Before removing the covers: <ul style="list-style-type: none"> ▪ De-energize all connections ▪ Lock out and tag out all switches ▪ If the device was already energized, wait 15 minutes so that the DC bus capacitors can discharge fully. ▪ Make sure that the unit is de-energized | Covers |
| | | <ul style="list-style-type: none"> ▪ Before putting the unit into operation, make sure that all electrical connections are undamaged and properly connected | Covers |
| Risk of electric shock posed by live parts | <ul style="list-style-type: none"> ▪ On the unit and on neighboring metal parts ▪ On the unit and on neighboring metal accessories | <ul style="list-style-type: none"> ▪ Before putting the unit into operation, make sure that it is bonded to an electrical ground system together with all metal accessories | Bonding system |
| Risk of electric shock due to bad water connection | <ul style="list-style-type: none"> ▪ In the entire work area as soon as the water hose bursts or starts leaking | <ul style="list-style-type: none"> ▪ Use a fixed connection ▪ Make sure that the water supply's water pressure is compatible with the pressure specified on the unit ▪ Use appropriate hoses as per the applicable requirements | none |

Safety hazard: mechanical unit components

When installing the unit, keep the following hazards in mind and take the actions required in order to eliminate and/or minimize these hazards:

| Risk / hazard | Where and in which situations will the risk/hazard exist? | What to do | Safety device |
|---------------------------------|---|---|---------------|
| Cut hazard posed by sharp edges | Whenever handling sheet metal parts | <ul style="list-style-type: none"> ▪ Exercise caution when performing these activities ▪ Wear the required personal protective equipment as indicated in the relevant safety instructions | None |

Safety hazard: cleaning agents

When installing the unit, keep the following hazards in mind and take the actions required in order to eliminate and/or minimize these hazards:

| Risk / hazard | Where and in which situations will the risk/hazard exist? | What to do | Safety device |
|---|---|--|---------------|
| Skin, eye, and respiratory tract irritation hazard as a result of contact with cleaning agents and their vapors | When installing the cleaning system | <ul style="list-style-type: none"> ▪ Wear the required personal protective equipment ▪ Observe the instructions and warnings on the cleaning agent labels and in the relevant safety data sheets | None |
| | Whenever using aggressive cleaning agents | Only use the cleaning agents specified in the 'Cleaning and maintenance' section of the operating manual (under 'Cleaning agents'). | None |

3.7 Hazards and Safety Measures When Putting the Unit into Operation

Safety hazard: electricity

When putting the unit into operation, keep the following hazards in mind and take the actions required in order to eliminate and/or minimize these hazards:

| Risk / hazard | Where and in which situations will the risk/hazard exist? | What to do | Safety device |
|--|--|--|----------------|
| Risk of electric shock posed by live parts | <ul style="list-style-type: none"> ▪ Under covers ▪ Under the operating panel ▪ All along the power cord | <ul style="list-style-type: none"> ▪ Work on the unit's electrical components should be performed exclusively by a qualified electrician from an authorized service company ▪ Work professionally | Covers |
| | | Before removing the covers: <ul style="list-style-type: none"> ▪ De-energize all connections ▪ Lock out and tag out all switches ▪ If the device was already energized, wait 15 minutes so that the DC bus capacitors can discharge fully. ▪ Make sure that the unit is de-energized | Covers |
| | | <ul style="list-style-type: none"> ▪ Before putting the unit into operation, make sure that all electrical connections are undamaged and properly connected | Covers |
| Risk of electric shock posed by live parts | <ul style="list-style-type: none"> ▪ On the unit and on neighboring metal parts ▪ On the unit and on neighboring metal accessories | <ul style="list-style-type: none"> ▪ Before putting the unit into operation, make sure that it is bonded to an electrical ground system together with all metal accessories | Bonding system |

Safety hazard: moving units on bases with casters

| Risk / hazard | Where and in which situations will the risk/hazard exist? | What to do | Safety device |
|--|--|---|-------------------|
| All the risks and hazards listed below | When units are being moved on a base with casters | <ul style="list-style-type: none"> ▪ Before moving the unit (to clean the combi oven's case or the floor, for example), check to make sure that the retaining element designed to limit how much the base can move with the unit is attached. ▪ De-energize the unit before moving it ▪ When moving the unit, make sure not to roll over any connection lines (electrical and water) | Retaining element |
| Pinch point hazard (for multiple body parts) | When units are being moved on a base with casters | <ul style="list-style-type: none"> ▪ Pay attention to the utility and hose connections. ▪ Use at least two people to move the unit | None |
| Pinch point hazard (hand and foot hazard) | When units are being moved on a base with casters | Keep the unit doors shut | None |
| Risk of scalding posed by hot wastewater | When units are being moved on a base with casters | <ul style="list-style-type: none"> ▪ Let the units cool down ▪ Immediately wipe or mop up any water that has leaked ▪ Wear appropriate protective clothing | None |
| Risk of scalding posed by hot, liquid food | When units are being moved on a base with casters | Do not move units if there is any food still in them | None |
| Risk of electric shock posed by live parts | When units are being moved on a base with casters | Pay attention to the utility and hose connections. | None |
| Skin and eye irritation hazard as a result of contact with cleaning agents | When units are being moved on a base with casters | <ul style="list-style-type: none"> ▪ Make sure that the connections are long enough ▪ When moving the base, keep the cleaning agent canisters closed | None |
| Trip hazard as a result of utility and hose connections routed in the open | When cleaning behind units that have been pulled forward | Exercise caution when performing maintenance work | None |
| Fall hazard as a result of floors being wet with wastewater | <ul style="list-style-type: none"> ▪ When cleaning behind units that have been pulled forward ▪ In front of the unit | <ul style="list-style-type: none"> ▪ Immediately wipe or mop up any water that has leaked ▪ Make sure that the connections are long enough | None |
| Fall hazard as a result of floors being wet with cleaning agents | <ul style="list-style-type: none"> ▪ When cleaning behind units that have been pulled forward ▪ In front of the unit | When moving the units, keep the cleaning agent canisters closed | None |

Additional safety hazards when placing the unit into operation

When putting the unit into operation, make sure to read and understand the following topics in the 'For Your Safety' section of the user manual in addition to the safety information in this section.

- Hazards and Safety Measures During Operation
- Hazards and Safety Measures During Cleaning
- Personal protective equipment

3.8 Hazards and Safety Measures When Removing the Unit from Service

Safety hazard: electricity

When removing the unit from service, keep the following hazards in mind and take the actions required in order to eliminate and/or minimize these hazards:

| Risk / hazard | Where and in which situations will the risk/hazard exist? | What to do | Safety device |
|--|---|--|---------------|
| Risk of electric shock posed by live parts | <ul style="list-style-type: none"> ▪ Under covers ▪ Under the operating panel | <ul style="list-style-type: none"> ▪ Work on the unit's electrical components should be performed exclusively by a qualified electrician from an authorized customer service company ▪ Work professionally <p>Before removing the covers:</p> <ul style="list-style-type: none"> ▪ De-energize all connections ▪ Lock out and tag out all switches ▪ Wait 15 minutes so that the DC bus capacitors can discharge fully ▪ Make sure that the unit is de-energized | Covers |

Safety hazard: moving heavy loads

When removing the unit from service, keep the following hazards in mind and take the actions required in order to eliminate and/or minimize these hazards:

| Risk / hazard | Where and in which situations will the risk/hazard exist? | What to do | Safety device |
|--|---|---|---------------|
| Risk of injury due to excessive exertion | Whenever moving the unit | <ul style="list-style-type: none"> ▪ Use appropriate lifting equipment ▪ Do not lift or carry too much weight! ▪ Wear the required personal protective equipment | None |

Safety hazard: moving units on bases with casters

| Risk / hazard | Where and in which situations will the risk/hazard exist? | What to do | Safety device |
|--|--|---|-------------------|
| All the risks and hazards listed below | When units are being moved on a base with casters | <ul style="list-style-type: none"> ▪ De-energize the unit before moving it ▪ Check to make sure that the retaining element that limits the moving radius for the base with the unit is attached before moving the base (in order to get access to the back of the unit, for example). ▪ When moving the unit, make sure not to roll over any connection lines (electrical and water) | Retaining element |
| Pinch point hazard (for multiple body parts) | When units are being moved on a base with casters | <ul style="list-style-type: none"> ▪ Pay attention to the utility and hose connections. ▪ Use at least two people to move the unit | None |
| Pinch point hazard (hand and foot hazard) | When units are being moved on a base with casters | Keep the unit doors shut | None |
| Risk of scalding posed by hot wastewater | When units are being moved on a base with casters | <ul style="list-style-type: none"> ▪ Let the units cool down ▪ Immediately wipe or mop up any water that has leaked ▪ Wear appropriate protective clothing | None |
| Risk of scalding posed by hot, liquid food | When units are being moved on a base with casters | Do not move units if there is any food still in them | None |
| Risk of electric shock posed by live parts | When units are being moved on a base with casters | Pay attention to the utility and hose connections. | None |
| Skin and eye irritation hazard as a result of contact with cleaning agents | When units are being moved on a base with casters | <ul style="list-style-type: none"> ▪ Make sure that the connections are long enough ▪ When moving the base, keep the cleaning agent canisters closed | None |
| Trip hazard as a result of utility and hose connections routed in the open | When cleaning behind units that have been pulled forward | Exercise caution when performing maintenance work | None |
| Fall hazard as a result of floors being wet with wastewater | <ul style="list-style-type: none"> ▪ When cleaning behind units that have been pulled forward ▪ In front of the unit | <ul style="list-style-type: none"> ▪ Immediately wipe or mop up any water that has leaked ▪ Make sure that the connections are long enough | None |
| Fall hazard as a result of floors being wet with cleaning agents | <ul style="list-style-type: none"> ▪ When cleaning behind units that have been pulled forward ▪ In front of the unit | When moving the units, keep the cleaning agent canisters closed | None |

Safety hazard: mechanical unit components

When removing the unit from service, keep the following hazards in mind and take the actions required in order to eliminate and/or minimize these hazards:

| Risk / hazard | Where and in which situations will the risk/hazard exist? | What to do | Safety device |
|---|--|--|--|
| Crush hazard posed by a loss of unit stability if the unit is set up in a stacking kit or on an equipment stand | <ul style="list-style-type: none"> ▪ When removing the unit from the equipment stand ▪ When removing units from a stacking kit ▪ If the top is subjected to a heavy uneven load | <ul style="list-style-type: none"> ▪ Do not, under any circumstance, subject the units to additional loads (on the open unit door, for example) ▪ Always remove the top unit from the stacking kit first ▪ Before removing units from a stacking kit with casters, lock the casters' wheels | Brake and swivel lock when using a stacking kit with casters |

Safety hazard: cleaning agents

| Risk / hazard | Where and in which situations will the risk/hazard exist? | What to do | Safety device |
|---|---|--|---------------|
| Skin, eye, and respiratory tract irritation hazard as a result of contact with cleaning agents and their vapors | <ul style="list-style-type: none"> ▪ When removing the cleaning system ▪ When disposing of the device | <ul style="list-style-type: none"> ▪ Wear the required personal protective equipment ▪ Observe the instructions and warnings on the cleaning agent labels and in the relevant safety data sheets | None |

3.9 Safety Devices

Meaning

The combi oven features a series of safety devices and guards that protect the user from a variety of hazards. All safety devices and guards must be present, fully functional, and locked properly without exception when the combi oven is being used.

Location

The following figures show where the safety devices and guards are located:

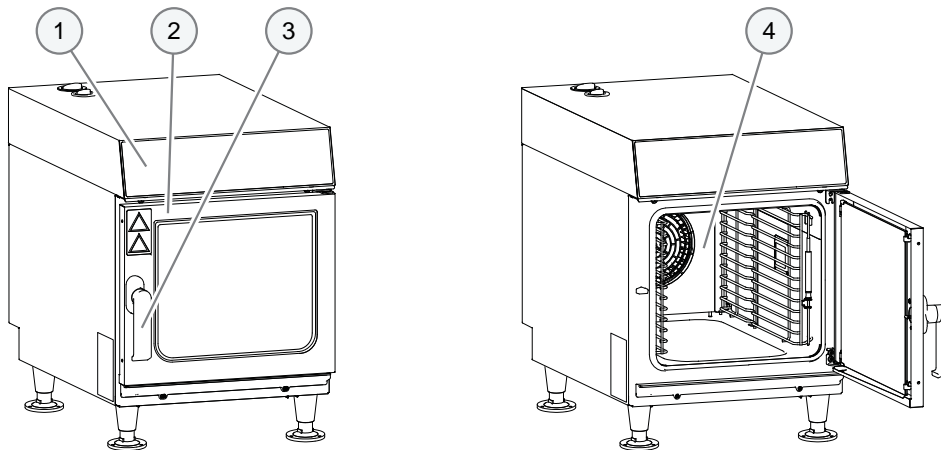

Functions

The following table lists all the safety devices and guards on the combi oven and explains what they do and how to inspect or test them:

| No. | Safety device | Function | Check |
|-----|--|--|--|
| 1 | Covers; can only be removed with tools | <ul style="list-style-type: none"> Prevents staff from accidentally touching live parts Prevents staff from reaching into the moving fan inside the wiring compartment | Check to make sure that the covers are in their proper place |
| 2 | Unit door with door solenoid switch | <p>Unit door: Protects the operator and the surroundings from hot steam</p> <p>Door solenoid switch (electrical door sensor):</p> <ul style="list-style-type: none"> Stops/turns off the following when the unit door is opened: <ul style="list-style-type: none"> Fan (will stop after a few seconds) Heating element Cleaning agent spraying in the fully automatic oven cleaning process Prompts the user to close the unit door | <p>Check for scratches, cracks, and other damage on a regular basis and replace it if you detect any damage</p> <p>Test the door solenoid switch with the combi oven at a low temperature</p> <p>Procedure:</p> <ul style="list-style-type: none"> Fully open the unit door Press Start <p>Result: The motor must not start running.</p> |

| No. | Safety device | Function | Check |
|-------------------------------|---|---|---|
| 3 | Unit door cracked-open position | Prevents steam coming out from scalding the operator's face and hands | With the combi oven at a low temperature, check the door positions as described in 'Safely Opening and Closing the Unit Door' in the operating manual |
| 4 | Suction panel inside the oven cavity; can only be removed with tools | Prevents staff from reaching into the moving fan and ensures proper heat distribution | Please refer to 'Removing and Installing the Suction Panel' in the operating manual |
| 5 (not shown) | Automatic safety rinsing after power outage if there was cleaning agent inside the combi oven when the power went out | Starts the fully automatic cleaning sequence (Convo-Clean system) again, from a defined state, after a power outage | The software will monitor this |
| 6 (not shown) | Spray stop | <ul style="list-style-type: none"> ▪ Stops cleaning agent spraying in the fully automatic cleaning sequence (Convo-Clean system) when the unit door is opened. ▪ Prompts the user to close the unit door | The software will monitor this |
| 7 (installed by the customer) | Disconnecter | <ul style="list-style-type: none"> ▪ Installed close to the unit by the customer. Easily visible and accessible, all-pole, with a contact gap of at least 0.12" ▪ Used to de-energize the unit during cleaning, repairs, and maintenance work, as well as in hazardous situations | Procedure: <ul style="list-style-type: none"> ▪ Trip the disconnecter ▪ Check that all three phases are de-energized at the unit's -X10 terminal block |
| 8 (not shown) | Only for setups involving a base with casters: Retaining element | Limits how much the entire setup (base and unit) can move from its location | Check to make sure that the retaining element is properly attached |

3.10 Staff and Work Area Requirements

Staff requirements

The table below specifies the qualifications needed for each role. Provided that they have the required qualifications, a single person can take over more than one role if necessary.

| Role | Required qualifications | Tasks |
|---|--|---|
| Combi oven owner or the owner's employee who is responsible for the unit and for the staff operating it | Is familiar with the rules involved in handling heavy loads | <ul style="list-style-type: none"> ▪ Briefed on all of the combi oven's safety-relevant functions, mechanisms, and devices by the person placing the unit into operation so that the information can be relayed to all the staff operating the unit ▪ Shown how the unit is operated by the person placing the unit into operation so that the information can be relayed to all the staff operating the unit ▪ If necessary, helping out as directed with transportation within the facilities and with setting up the unit |
| Mover | <ul style="list-style-type: none"> ▪ Trained in the use of forklifts and/or pallet jacks ▪ Is familiar with the rules involved in handling heavy loads | Transporting the unit within the facilities |
| Service technician | <ul style="list-style-type: none"> ▪ Qualified staff from an authorized service company ▪ Has relevant technical training ▪ Has unit-specific training ▪ Is familiar with the rules involved in handling heavy loads ▪ Is able to assess whether the unit's power, water, and drain connections have been correctly set up. | <ul style="list-style-type: none"> ▪ Setting up the unit ▪ Installing the fully automatic oven cleaning system ▪ Placing the unit into operation ▪ Removing the unit from service |
| Electrician | <ul style="list-style-type: none"> ▪ Qualified staff from an authorized service company ▪ Has relevant training ▪ Is a qualified electrician | <ul style="list-style-type: none"> ▪ Connecting the unit to the electrical connection at the facilities ▪ Uninstalling electrical connections |
| Water and wastewater installer | <ul style="list-style-type: none"> ▪ Qualified staff from an authorized service company ▪ Has relevant training | <ul style="list-style-type: none"> ▪ Connecting the unit to the water connection at the facilities ▪ Uninstalling water connections ▪ Connecting the unit to the drain connection at the facilities ▪ Uninstalling the drain connection |
| Person placing the unit into operation (service technician) | <ul style="list-style-type: none"> ▪ Is an employee from an authorized service company who is responsible overall for placing the unit into operation ▪ Has relevant technical training ▪ Has unit-specific training ▪ Is familiar with the rules involved in handling heavy loads ▪ Is able to assess whether the unit's power, water, and drain connections have been correctly set up. | <ul style="list-style-type: none"> ▪ Briefing the owner or the responsible employee ▪ Checking all steps and conditions as per the checklists |

Work areas during installation and placement into operation

During installation and placement into operation, the work area for staff will be the entire area occupied by the unit and its surroundings.

3.11 Personal protective equipment

Transportation and setup

Wear the following personal protective equipment when transporting and setting up the combi oven:

| Task | Tools used | Personal Protective Equipment |
|--|-------------------------------|--|
| <ul style="list-style-type: none"> ▪ Transporting the unit within the facilities ▪ Setting up the unit on a work table or stand or inside a stacking kit ▪ Setting up the unit at the installation location | Appropriate lifting equipment | <ul style="list-style-type: none"> ▪ Protective gloves ▪ Safety footwear ▪ A hard hat (e.g., when there are suspended loads, doing overhead work) |

Installation, placing the unit into operation, and removing it from service

| Task | Tools used | Personal Protective Equipment |
|--|---|---|
| Installing and uninstalling (removing from service) the following: <ul style="list-style-type: none"> ▪ Electrical connection ▪ Water connection ▪ Drain connection | Tools and equipment necessary for the specific task at hand | Work clothes and personal protective equipment based on the required task in accordance with country-specific regulations |
| Installing and uninstalling the fully automatic oven cleaning system | Tools and equipment necessary for the specific task at hand | The protective equipment required will depend on the cleaning agents being used, and may include: <ul style="list-style-type: none"> ▪ Respirator ▪ Safety eyewear ▪ Protective gloves ▪ Protective clothing/apron More detailed specifications regarding this equipment can be found in the EC safety data sheets for the cleaning agent(s) being used. For the latest version of these data sheets, please contact the manufacturer. Always follow the instructions and observe all warnings found on the labels used for the cleaning agent(s). |
| <ul style="list-style-type: none"> ▪ Placing the unit into operation ▪ Briefing the user | Tools and equipment necessary for the specific task at hand | Wear appropriate work clothes for kitchen work as required by your country-specific standards and regulations, especially: <ul style="list-style-type: none"> ▪ Protective clothing ▪ Heat-resistant gloves ▪ Safety footwear |
| Removing the unit (removing it from service) | <ul style="list-style-type: none"> ▪ Carrying straps ▪ Appropriate lifting equipment ▪ A forklift or pallet jack | <ul style="list-style-type: none"> ▪ Protective gloves ▪ Safety footwear ▪ A hard hat (e. g., when there are suspended loads, doing overhead work) |

4 Transportation

Purpose of this section

This section provides information on how to transport your unit.

This section is intended for the user, as well as for installers and authorized customer service companies.

4.1 Working Safely During Transportation

For Your Safety

Before starting your work, read and understand the hazards described in Hazards and Safety Measures During Transportation on page 22.

Personnel qualifications required for transporting the unit

Required qualifications for transporting the unit:

- The unit should be transported exclusively by personnel trained in the use of forklifts and/or pallet jacks.
- All staff must be familiar with the rules involved in handling heavy loads.

Personal protective equipment

Wear the personal protective equipment specified for your work in the 'Personal Protective Equipment' on page 37 section of 'For Your Safety'.

Moving heavy loads

WARNING

Risk of injury when lifting loads incorrectly

Lifting the unit incorrectly may result in injury (especially in the area of the torso) due to the unit's weight.

- ▷ Use a forklift, pallet jack, or appropriate lifting equipment to transport the unit.
- ▷ When lifting the unit, make sure to use an appropriate number of people as required by the unit's weight (guideline: 30 lbs to a maximum of 120 lbs depending on age, sex, and build). Comply with all occupational health and safety regulations that apply at the installation location!
- ▷ Wear the required personal protective equipment.

Unsuitable supporting surfaces

WARNING

Crush hazard posed by the unit falling down or toppling over

Body parts may be crushed if the unit falls down or topples over.

- ▷ Make sure never to place the unit on an unsuitable supporting surface.

4.2 Transporting the unit to the installation location

Required space during transportation

Make sure that the transportation route you will be following has enough space to accommodate the unit's entire width and height at all times.

The following table provides the minimum door width and height required in order to be able to get the combi oven to its intended installation location.

| | | Minimum door opening dimensions |
|--------|------|---------------------------------|
| Width | [in] | 22.8 |
| Height | [in] | 32.7 |

Load capacity for transportation

Make sure that the transportation equipment you will be using is able to handle the loads it will be transporting.

The required minimum load capacity for the transportation equipment is 150 lbs.

Transporting the unit to the installation location

Observe the following when transporting the unit:

- Always use a pallet to transport the unit.
 - Always keep the unit upright when moving it.
 - Transport the unit slowly and carefully and secure it in such a way that it cannot tip over. Make sure not to bump into the unit.
- Avoid uneven transportation routes and steep inclinations.

5 Setup

Purpose of this section

This section provides information on how to set up your unit.

This section is intended for the user, as well as for installers and authorized customer service companies.

5.1 Working Safely During Setup

For Your Safety

Before starting your work, read and understand the hazards described in Hazards and Safety Measures During Setup on page 23.

Personnel qualifications required for setting up the unit

Required qualifications for setting up the unit:

- The unit should be set up exclusively by qualified technicians from an authorized customer service company.

Setup standards and regulations

All national, state, and local standards and regulations concerning commercial kitchen operations must be complied with. These include, but are not limited to, the Food Code published by the Food and Drug Administration (FDA) (current edition) and the standards published by the National Sanitation Foundation (NSF).

The local rules and regulations that apply to the installation location, as defined by the relevant local authorities and utility companies, must be complied with.

Personal protective equipment

Wear the personal protective equipment specified for your work in the 'Personal Protective Equipment' on page 37 section of 'For Your Safety'.

Moving heavy loads

WARNING

Risk of injury when lifting loads incorrectly

Lifting the unit incorrectly may result in injury (especially in the area of the torso) due to the unit's weight.

- ▷ Use appropriate lifting equipment when placing the unit on a work table or equipment stand or in a stacking kit.
- ▷ When adjusting the unit's location, make sure to use an appropriate number of people to lift the unit as required by the latter's weight (guideline: 30 kg to a maximum of 120 kg depending on age and sex). Comply with all occupational health and safety regulations that apply at the installation location!
- ▷ Wear the required personal protective equipment.

Unsuitable supporting surfaces

WARNING

Crush hazard posed by the unit falling down or toppling over

Body parts may be crushed if the unit falls down or topples over.

- ▷ Make sure never to place the unit on an unsuitable supporting surface.

5.2 Adjacent Systems

Handling exhaust air

During operation, the combi oven will produce heat and moisture, most of which will escape upwards into the ambient air in the form of hot steam coming through the air vent. Do not connect any lines or ducts directly to the combi oven's air vent!

The manufacturer recommends removing this exhaust air from the combi oven's working area with a range hood or ventilated ceiling.

In order to prevent fire hazards and other structural issues, such as corrosion, mold, and/or a decrease in stability, there must be sufficient clearance between the top of the unit and the ceiling. This clearance must be determined by taking the following into account:

- The reference point for the minimum vertical clearance (refer to 'Installation Location Requirements' on page 42).
- The type of exhaust system being used
- The characteristics of the ceiling at the installation location

The combi oven must always be set up, installed, and operated in compliance with all applicable country-specific and local standards and regulations.

5.3 Installation location requirements

Meaning

This section provides information on how to choose a suitable installation location for the unit. Carefully check the intended installation location to make sure it is adequate before bringing the unit there and starting with the installation!

Rules for safely setting up the unit

In order to prevent hazards that may be posed by the installation location and by the unit's surroundings, follow the rules below:

- It must be possible to adhere to the operating conditions at all times. For these operating conditions, please refer to 'Requirements concerning the combi oven's surroundings on page 19'.
- The heat loss at hot surfaces poses a fire hazard. Accordingly, set up the unit in non-combustible environments only.
- There must not be any flammable materials, gases, or liquids at a distance of less than 18" from the sides of the unit (right, left, front, back) and 40" from the top of the unit. When choosing an installation location, make sure to observe this requirement together with the requirements in the 'Adjacent Systems' on page 41 section and the unit's minimum space requirements without exception!
- Substructures (tables, frames) and supporting surfaces (floors, bases, countertops) must be made of non-combustible materials and must not be coated or covered with any flammable materials (no fiberboard, no contact between flammable materials and the bottom of the unit). Likewise, there must not be any flammable materials on the undersides of these structures. The unit supporting surfaces on substructures of this type must project beyond the unit's base on all sides by 12" or more.
- The minimum distance from heat sources in the vicinity of the units is 20".
- The minimum distance that must be maintained between the unit and any deep fryers or open kettle fryers in the vicinity is 40". The unit must be set up in such a way that liquids from the unit and from cooking processes will not be able to get to deep fryers and open kettle fryers under any circumstance. Units mounted on a wall mount must not be placed over a deep fryer, an open kettle fryer, or an electric appliance.
- Do not set up the unit directly under a fire alarm or sprinkler system. The sensitivity of fire alarms and sprinkler systems must be adjusted in line with the amount of vapor and steam that the unit is expected to produce.
- The connection between the combi oven's drain pipe and the sewer system must be located outside the perimeter of the unit's base area. Due to potential wastewater vapors, there must not be a drain connection or open sewer line below the unit's base area.
- It must be possible to set up the unit's base (work table, equipment stand, or stacking kit) at the installation location in such a way that it will not topple over or shift. All supporting surface requirements must be met.
- The unit's base (equipment stand or stacking kit) must be secured in such a way that it cannot topple over if it is subjected to an uneven load (due to an open unit door, for example).
- In the case of units placed on a base with casters, a retaining element that limits how much the whole setup (base and unit) can move must be attached. It must not be possible to pull the base with the unit more than 20" forward.
The length of the corresponding utility and hose connections must take into account how much the retaining element will allow the base and unit to move. Do not roll over, pull, or otherwise subject the utility and hose connections to any tension when moving the whole setup (base and unit).
- The casters on the base must be lockable.
- With its current configuration, the unit is not designed to be used in environments where it could be subjected to strong vibrations or mechanical shock (e.g., on vehicles or ships).
- Vibrations must be avoided when using equipment stands or stacking kits.

Supporting surface requirements

The supporting surface must have the following characteristics:

- The supporting surface must be flat and level.
- The supporting surface must be capable of bearing the unit's weight during operation, plus the weight of the corresponding base.
- The base (work table or equipment stand) must be able to support a load equal to the unit's weight during operation.

The following table lists the various weights that make up the unit's weight during operation:

| Without base | Weight |
|---|-------------------------------|
| Unit weight when empty | [lbs] 121 |
| Maximum permissible loading weight | [lbs] 44 |
| Maximum weight of cleaning agents | [lbs] 44 |
| Unit weight during operation without base | [lbs] 209 |
| Base | Weight |
| Equipment stand weight | [lbs] 27 |
| With base | Weight |
| Unit weight during operation with equipment stand | [lbs] 236 |
| Unit weight during operation with work table | [lbs] 209 + work table weight |

Space required

In order to ensure that the combi oven will be used safely – especially when it comes to safely handling hot food –, it is necessary to keep a lot more free space than the minimum in front of the units! Generally speaking, it is recommended to maintain large clearances between the units and the walls in order to make it easier for service staff to access the unit as needed.

Do not cover, obstruct, or block the following parts at the installation location (please refer to 'The Combi Oven's Configuration and Functions on page 13' as well):

- The air vents at the top of the unit
- The dry air intake at the top of the unit
- Vents at the back of the unit
- Opening at the front between the feet

Minimum required space – width and depth

The following diagrams, as well as the following table, show the space required by the unit for various installation and operating situations, as well as the minimum horizontal clearances required relative to adjacent walls and surfaces.

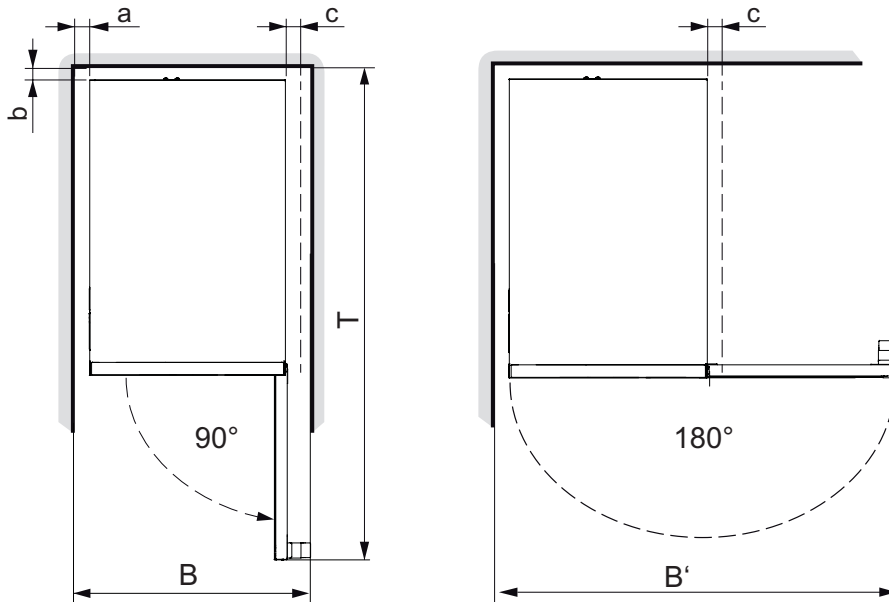

| Dimension | Meaning | Required space |
|-----------|--|----------------|
| B | Minimum required space for the unit width when the door is opened 90° | [in] 24.9 |
| B' | Minimum required space for the unit width when the door is opened 180° | [in] 41.5 |
| D | Minimum required space for the unit depth (including open door) | [in] 51.8 |
| a | Minimum wall clearance on the left side of the unit | [in] 2.0 |
| b | Minimum wall clearance at the back of the unit | [in] 2.0 |
| c | Minimum wall clearance on the right side of the unit | [in] 2.0 |

Minimum space requirements – height

The following diagram and table show the vertical space required by the unit:

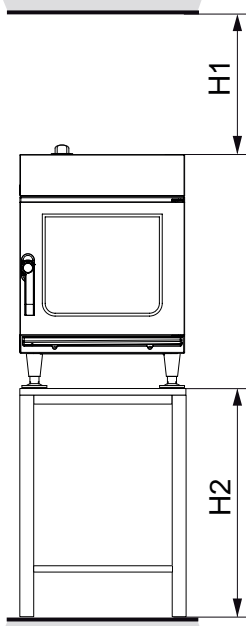

The service technician responsible for setting up the unit must take into account the ceiling's properties and any adjacent systems being used (air ventilation system, range hood) when determining the actual clearance required between the top of the unit and the ceiling. Vertical clearance H1 is only meant to serve as a reference point for the minimum vertical clearance.

| Dimension | Meaning | Required space | |
|-----------|--|----------------|-------------|
| H1 | Reference point for minimum vertical clearance | [in] | 20.0 |
| H2 | Installation height | [in] | 27.6 - 35.4 |

The topmost shelf must not be at a height exceeding 63".



This requirement will be met automatically if the unit is set up on one of the manufacturer's equipment stands. Please refer to Equipment stand dimensions and weights for more information.

5.4 Unpacking

Checking the tilt indicator

Before unpacking the unit, check the tilt indicator on the packaging.

The following table shows the various possible tilt indicator conditions:

| Indicator | Meaning | Procedure |
|--|---|---|
|  | Silver dot: The unit has been transported properly. | <ul style="list-style-type: none"> Unpack the unit Compare the tilt indicator's number with the number on the shipping documents. |
|  | Red dot: The device has been transported in a toppled or non-upright position. | <ul style="list-style-type: none"> Check the goods for damage. Compare the tilt indicator's number with the number on the shipping documents. Make a note of the tilt indicator dot color and of any damage on the shipping documents. |

Unpacking the unit

How to unpack the unit:

| Step | Procedure | Figure |
|------|--|--|
| 1 | Remove the outer packaging. | |
| 2 | Remove all cardboard boxes, packaging materials, customer documents, labels, and containers. Please make sure to dispose of all packaging materials in an environmentally responsible manner. | |
| 3 | Remove the protective film. |  |
| 4 | Check the combi oven for damage. If you suspect there is any transit damage, immediately notify your specialty retailer/carrier. In addition, notify the manufacturer in writing within three days. Do not, under any circumstance, install or operate damaged units. | |

Included equipment and parts

The following should be included with the unit:

- One combi oven
- One left-hand side rack
- One right-hand side rack
- One installation manual
- One operating manual
- One operating instructions document for easyStart

5.5 Setting up the unit on a work table

⚠ Rules for safely setting up the unit

Observe the following rules in order to ensure that the unit will have the required stability:

- It must be possible to set up the work table at the installation location in such a way that it will not topple over or shift. All supporting surface requirements must be met.
- The unit must be set up on the work table's surface in such a way that it will not topple over or shift.

Setting up the unit on a work table

Follow the steps below when setting up the unit on a work table:

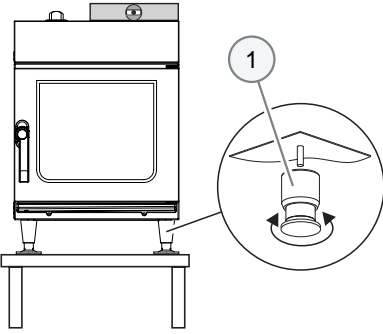
| Step | Procedure | Figure |
|------|--|--|
| 1 | Place the unit on the work table. |  |
| 2 | Use the unit's height-adjustable feet (1) to level the unit. Use a spirit level to make sure that the unit is properly leveled. | |

5.6 Setting Up the Unit on a Stand

⚠ Rules for safely setting up the unit

Observe the following rules in order to ensure that the unit will have the required stability:

- The unit's equipment stand must be secured in such a way that it cannot topple over if it is subjected to an uneven load (due to an open unit door, for example).
- It must be possible to set up the stand at the installation location in such a way that it will not topple over or shift. All supporting surface requirements must be met.

In order to comply with hygiene standards, the following rule must be observed:

- In the case of equipment stands with shelf levels for bakeware, the equipment stands' upper panel must be correctly in place in order to prevent food being temporarily stored in the equipment stand from being contaminated.

Setting Up the Unit on a Stand

Follow the steps below when setting up the unit on an equipment stand:

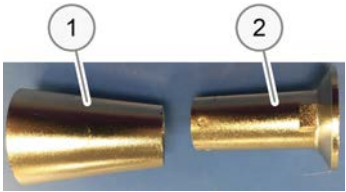
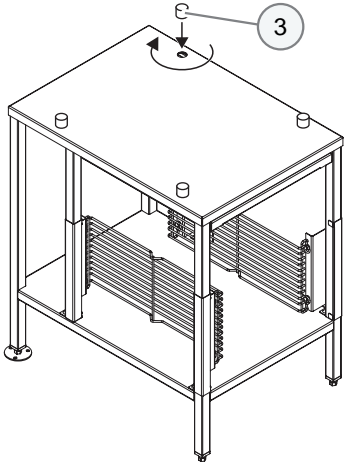
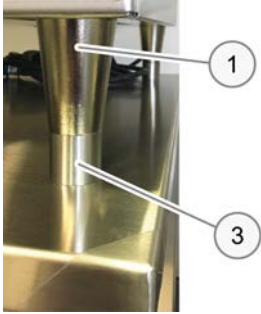
| Step | Procedure | Figure |
|------|--|---|
| 1 | Unscrew the four feet and remove them completely from the unit. | |
| 2 | Unscrew and remove the lower part (2) of the foot and then screw the upper part (1) of the foot back onto the unit. You will not be needing the lower part of the foot anymore. |  |
| 3 | Screw the four spacers (3) included with the stand onto the stand. |  |
| 4 | Set the unit on the stand and insert the feet (1) into the sleeve mounts (3) so that they will be securely in place. |  |

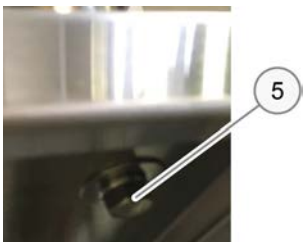
| Step | Procedure | Figure |
|------|---|---|
| 5 | Use the enclosed screws (5) to screw the unit onto the equipment stand from below. |  |
| 6 | Position the device with the stand and use the height-adjustable feet to level the stand. Use a spirit level to make sure that the unit is properly leveled. | |
| 7 | Fasten the base on the flange feet. | |

6 Installation

Purpose of this section

This section goes over how to connect your combi oven.

6.1 Electrical installation

Purpose of this section

This section goes over how to electrically install the unit.

6.1.1 Working Safely When Installing the Electrical Installation

For Your Safety

Before starting your work, read and understand the hazards described in Hazards and Safety Measures During Installation on page 25.

Personnel qualifications required for electrically installing the unit

Work on electrical equipment should be performed exclusively by electricians from an authorized service company who have the training and certifications required by all applicable country-specific and local regulations.

Personal protective equipment

Wear the personal protective equipment specified for your work in the 'Personal Protective Equipment' on page 37 section of 'For Your Safety'.

Electrical installation standards and regulations

In order to prevent hazards related to improperly installed electrical connections, make sure to observe the following standards and regulations:

- The connection to the power supply must be installed in accordance with the National Electrical Code, ANSI/NFPA 70 (current edition); the Canadian Electrical Code, CSA C22.2; all other applicable national and state laws and regulations; and the local requirements set forth by the relevant local utility companies, trade associations, and authorities.

Live parts

WARNING

Risk of electric shock posed by live parts and loose cables

Electric shock may occur when coming into contact with live parts after opening the cover.

- ▷ Make sure that all electrical work is performed exclusively by a qualified electrician from an authorized customer service office.
- ▷ Follow the steps below before removing the safety covers:
 - De-energize all connections.
 - Lock out and tag out all switches.
 - If the device was already energized, wait 15 minutes so that the DC bus capacitors can discharge fully.
 - Make sure that the unit is de-energized.
- ▷ Before putting the unit into operation, make sure that all electrical connections are undamaged and firmly connected.
- ▷ Before putting the unit into operation, make sure that it is bonded to an electrical ground system together with all metallic accessories.

6.1.2 Planning the Electrical Installation

Meaning

It is crucial for the unit's electrical system to be properly installed in order for the unit to run safely and without any problems. All the rules and specifications specified in this section, as well as the procedures described, must be followed to the letter.

Rules for safely installing the units electrically

In order to prevent hazards related to improperly installed electrical connections, make sure to observe the following rules:

- The unit's case must be properly grounded as per generally accepted standards and practices and connected to an electrical ground system.
- If there are two units mounted in a single stacking kit, both the units' cases and the stacking kit must be properly grounded as per generally accepted standards and practices and connected to an electrical ground system.
- The length of the field installed conductors and the length of the flexible conduit must take into account how much the retaining element on the base allows the unit to move. Do not roll over, pull, or otherwise subject the field installed conductors to any tension when moving the whole setup (base and unit). This also applies to any other additional electrical connection cables between the combi oven and optional accessories, such as a signal tower.
- While placing the unit into operation, check all electrical cables and connections to make sure they have been routed properly and installed correctly as per generally accepted standards and practices.

Equipment provided by the customer and electrical installation rules

The following table shows the equipment that must be provided by the customer and the rules that have to be followed when making the relevant electrical connections.

| Equipment | Rules |
|--------------------------|--|
| Fuse | The unit must be fused and connected in accordance with all applicable local regulations and country-specific installation regulations. |
| Electrical ground | The unit must be connected to an electrical ground system. If there are two units mounted in a single stacking kit, both the units' cases and the stacking kit must be properly connected to an electrical ground system. Electrical ground: An electrical connection that brings the frames of electrical equipment and other conductive parts to the same or approximately the same potential. |
| Disconnecter | An easily accessible all-pole power disconnection with a contact gap of at least 0.12" must be installed. The unit must be connected through this power disconnector. The power disconnection will then be used to de-energize the unit before performing cleaning, repair, and installation work. Installation must comply with all applicable local standards and regulations. In the case of permanent installations, a disconnecter is required. |

Power supply

The power cord must be an oil-resistant, jacketed, flexible cable that complies with the applicable local regulations. It is recommended for the field installed conductors not to exceed a length of 5½ ft. A warning label must be affixed to the power cord; please refer to 'Warning labels on the combi oven' on page 20.

The length of the power cord used for units placed on a base with casters must take into account how much the retaining element on the base allows the unit to move. Do not pull or otherwise subject the field installed conductors to any tension when moving the whole setup (base and unit).

A specific phase rotation direction or phase sequence is not required when connecting the unit.

6.1.3 Performing the Electrical Installation

Prerequisites

Check whether the following prerequisite is met:

- The unit's connection point has been de-energized and locked and tagged out.

Checking the rating data and electrical connections

Follow the steps below to check the connection to the electrical system and the electrical connections:

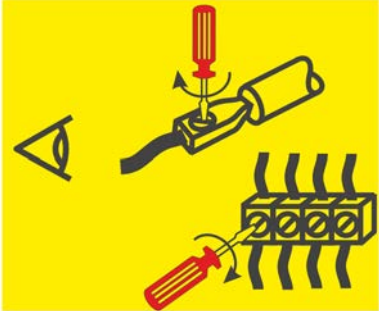
| Step | Procedure | Figure |
|------|---|--|
| 1 | Remove the unit's rear panel. The circuit diagram and the spare parts list will be located inside the wiring compartment. | |
| 2 | Check to make sure that the electrical rating data on the nameplate matches the specifications in the circuit diagram and the characteristics of the building's electrical system. Do not connect the combi oven unless all specifications match. | |
| 3 | Check all screw and crimp terminal connections on the unit. The connections may have become loose during transportation. |  |

Performing the Electrical Installation

Follow the steps below to electrically connect your unit:

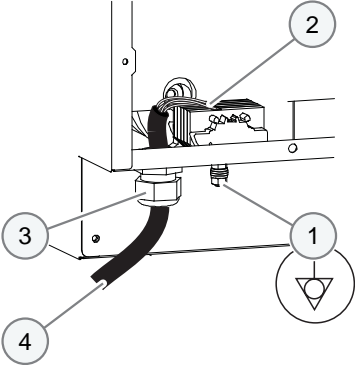
| Step | Procedure | Figure |
|------|--|---|
| 1 | Connect the unit to an electrical ground system at the intended connection point (1). |  |
| 2 | Check to make sure that the power cord is properly connected to terminal block -X10 (2). | |
| 3 | Make sure that the cable fitting (3) has a secure fit. This fitting serves as a strain relief. | |
| 4 | If necessary, reset the safety thermostat. | |
| 5 | Put the unit's rear panel back in place and check that it is mounted properly. | |
| 6 | Connect the appropriate power plug to the power cord (4). | |
| 7 | Carry out the relevant country-specific electrical tests. | |

6.2 Water connection

Purpose of this section

This section goes over how to set up the water connection.

6.2.1 Working Safely When Setting Up the Water Connection

For Your Safety

Before starting your work, read and understand the hazards described in Hazards and Safety Measures During Installation on page 25.

Personnel qualifications required for the water connection

The combi oven should be connected to the water supply and the wastewater system exclusively by trained technicians from an authorized service company who specialize in water and wastewater system installations.

Personal protective equipment

Wear the personal protective equipment specified for your work in the 'Personal Protective Equipment' on page 37 section of 'For Your Safety'.

Water connection standards and regulations

Make sure to comply with all national and state laws and regulations that apply to the water connection, as well as with all applicable local requirements and regulations set forth by the relevant local water utilities and authorities. These include, but are not limited to:

- Latest edition of the International Plumbing Code published by the International Code Council (ICC) or the Uniform Plumbing Code published by the International Association of Plumbing and Mechanical Officials (IAPMO)
- The Food Service Sanitation Manual published by the Food and Drug Administration (FDA)
- The standards published by the National Sanitation Foundation (NSF)

The unit may need to be installed with an appropriate backflow preventer in order to comply with all applicable federal, state, and local laws and regulations.

Drain connection standards and regulations

Make sure to comply with all national and state laws and regulations, as well as with all applicable local requirements and regulations set forth by the relevant local utilities and authorities, that apply to the drain connection and to the wastewater's properties. These include, but are not limited to:

- Latest edition of the International Plumbing Code published by the International Code Council (ICC) or the Uniform Plumbing Code published by the International Association of Plumbing and Mechanical Officials (IAPMO)
- The Food Service Sanitation Manual published by the Food and Drug Administration (FDA)
- The standards published by the National Sanitation Foundation (NSF)

6.2.2 Water supply

⚠ Rules for safely installing the water connection

In order to prevent hazards related to an improperly installed water connection, make sure to observe the following rules:

- In the case of units placed on a base with casters, the water connection must use a flexible hose.
- The length of the water connection line must take into account how much the retaining element on the base allows the unit to move. Do not roll over, pull, or otherwise subject the water connection hose to any tension when moving the whole setup (base and unit).
- The unit must be connected to a cold water pipe.

Water connection configuration

The combi oven is designed for a fixed water connection installed on-site. Mesh strainers must be used.

Connecting the water connection with a flexible connection hose

The unit can be connected to the water supply using a flexible GHT-M water connection hose that has a 3/4" fitting. Mesh strainers must be used.

Water quality and water hardness

Check the water quality as explained in 'Checking the Water Quality'.

Compare the water quality and water hardness of the water supplied through the building's supply connection with the specifications in the 'Technical Data' section (please refer to Water quality on page 72). If the required conditions are not met, you must install an adequate water filter and water treatment equipment. For more information on the required sizing, please refer to the Technical data and connection drawing on page 70 section.

Installation diagram with water treatment system

The following diagram shows the connection diagram for installations with a water treatment system:

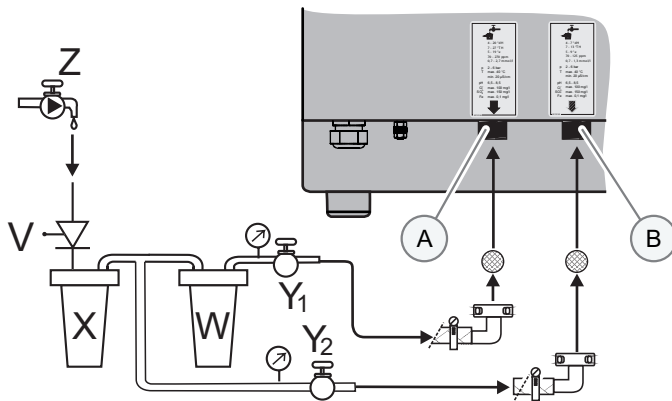

| No. | Designation | Explanation |
|-----|---------------------------------------|--|
| A | Soft water connection | For drinking water quality information, refer to the 'Technical Data' on page 70 section |
| B | Cold water connection | |
| Z | Water supply provided by the customer | Drinking water quality |
| X | 0.003" sediment filter | A 0.003" sediment filter needs to be installed if the water has a lot of impurities. |
| W | Water treatment system | If the required values are exceeded, a water treatment system must be installed. |

| | | |
|----------|------------------------------------|--|
| Y | Shut-off device with mesh strainer | Water valve |
| V | Appropriate backflow preventer | The unit must be installed with an appropriate backflow preventer in order to comply with all applicable federal, state, and local laws and regulations. |

Installing the water supply connection

Follow the steps below to set up the water supply for your combi oven:

| Step | Procedure |
|------|--|
| 1 | Ask your local water company for information regarding the quality and hardness of the water you get. If required, use suitable water treatment solutions. For information on the required properties for the fresh water used with the unit, please refer to the Technical Data on page 70 section. |
| 2 | Flush the water connection on the on-site water line (Z). |
| 3 | Install the sediment filter (X) and, if necessary, a water treatment system (W). |
| 4 | Install a separate shut-off device with a mesh strainer for each unit (Y or Y ₁ /Y ₂). |
| 5 | Install an appropriate backflow preventer (V) in the water supply line if required by local regulations. |
| 6 | Connect the unit as shown in the connection drawing. |
| 7 | Flush the sediment filter and, if applicable, the water treatment system. |
| 8 | Once you are done installing the water connection, close the shut-off device. |
| 9 | Inform the user of the maintenance intervals for the filters and for the water treatment system (if any). |

6.2.3 Water drain

⚠ Rules for safely installing the drain connection

In order to prevent hazards related to an improperly installed drain connection, make sure to observe the following rules:

- The drain pipes must be made of PVC or copper and must be able to withstand a temperature of 140 °F.
- The drain pipe must not taper or have any other diameter-reducing deformations at any point.
- The drain pipe's minimum diameter will depend on the pipe's total length and the number of elbows used. For a pipe length of up to 6 feet and a maximum of two elbows, the minimum inner diameter will be 1½". For a pipe length of 6 to 12 feet or a maximum of three elbows, the minimum inner diameter will be 2".
- The drain pipe must have a downward slope of at least 5% (3°).
- The unit drain must not be directly connected to the sewer system vertically.
- The connection between the drain pipe and the sewer system must be located outside the perimeter of the unit's base area. Due to potential wastewater vapors, there must not be a drain connection or open sewer line below the unit's base area.
- The drain connection must be implemented using a rigid, naturally ventilated pipe.
- A ventilation clearance of at least 1" must be maintained between the end of the drain pipe and the upper edge of the drain or pan.
- No other units may be connected to the combi oven's drain pipe.
- The combi oven must not be connected to any other units' drain pipe.

Connection diagram

The following diagram shows the connection diagram for a fixed wastewater connection installation:

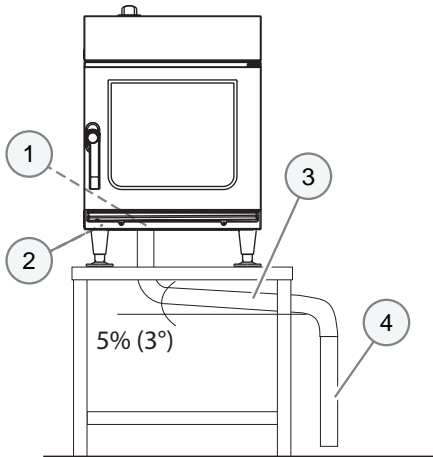

| No. | Meaning | Explanation |
|-----|---------------------|--|
| 1 | Drain connection | <ul style="list-style-type: none"> ▪ At the back of the combi oven. Connection drawing: point C |
| 2 | Safety overflow | <ul style="list-style-type: none"> ▪ At the bottom of the combi oven. Connection drawing: point M ▪ Used to drain water in the event of a failure (blockage) |
| 3 | 1½" drain pipe | <ul style="list-style-type: none"> ▪ Minimum inner diameter = 1½" ▪ Downward slope: min. 5% (3°) |
| 4 | 1½" (2") drain pipe | <ul style="list-style-type: none"> ▪ Minimum inner diameter = 1½" (2") ▪ Downward slope: min. 5% (3°) |

Installing the water drain

Follow the steps below to set up the water drain for your combi oven:

| Step | Procedure |
|------|--|
| 1 | Connect the unit as shown in the connection diagram. |

6.3 ConvoClean System Installation

Purpose of this section

This section goes over how to set up the fully automatic ConvoClean oven cleaning system.

6.3.1 Working Safely When Installing the ConvoClean System

For Your Safety

Before starting your work, read and understand the hazards described in Hazards and Safety Measures During Installation on page 25.

Personnel qualifications required for installing the ConvoClean system

The unit should be connected exclusively by qualified technicians from an authorized customer service company.

Personal protective equipment

Wear the personal protective equipment specified for your work in the 'Personal Protective Equipment' on page 37 section of 'For Your Safety'.

Contact with cleaning agents

WARNING

Risk of chemical burns and skin, eye, and respiratory tract irritation

The ConvoClean new cleaning agent and the ConvoCare rinse aid will cause skin, eye, and respiratory tract irritation upon direct contact. The ConvoClean forte cleaning agent will result in chemical burns to the skin, eyes, and respiratory tract upon direct contact.

- ▷ Do not inhale the cleaning agents' and rinse aid's vapors or mist.
- ▷ Do not let the cleaning agents or rinse aid come into contact with your eyes, skin, or mucous membranes.
- ▷ Observe all the instructions and warnings on the cleaning agent labels and in the corresponding safety data sheets when handling cleaning agents.
- ▷ Wear the required personal protective equipment.

6.3.2 Components of Fully Automatic Oven Cleaning System

Cleaning agents and rinse aid

Only use the products specified here in order to clean the combi oven.

NOTICE! The warranty will be void if there is any damage that can be traced back to the use of incorrect cleaning agents.

The following table lists the cleaning agents and rinse aids that can be used:

| Designation | Product | Label color |
|-----------------|------------------|-------------|
| Cleaning agents | ConvoClean forte | Red |
| Rinse aid | ConvoCare | Green |

Components of Fully Automatic Oven Cleaning System

The following diagram shows how the fully automatic oven cleaning system is laid out:

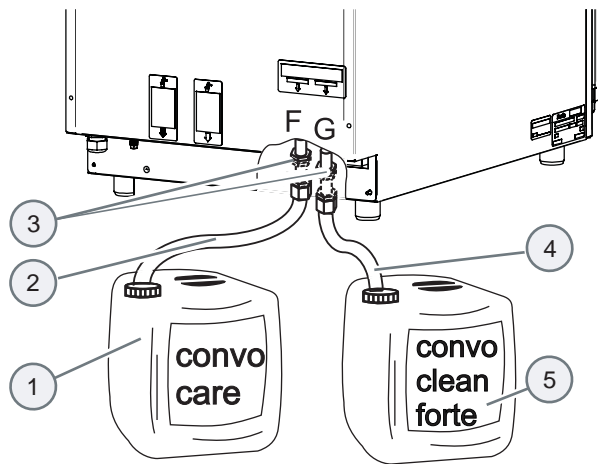

| No. | Designation | Color coding |
|-----|---|---------------------|
| 1 | ConvoCare rinse aid canister | Green (label) |
| 2 | Suction tube with suction nozzle for rinse aid | Green (tube) |
| 3 | D10 wire hose clamp | - |
| 4 | Suction tube with suction nozzle for cleaning agent | Red (tube) |
| 5 | ConvoClean forte cleaning agent canister | Red (label) |
| F | Unit connection for rinse aid | Green (inscription) |
| G | Unit connection for cleaning agent | Red (inscription) |

Installation location for cleaning agent and rinse aid canisters

Set up the canisters as follows:

- The canisters should be easily accessible on a flat, level surface next to the device.
- The canisters' location must be lower than the level at which the unit is resting on its base.
- The contact point between the canisters and their supporting surface must not be more than 40" below the bulkhead fittings.

6.3.3 Connecting the Fully Automatic Cleaning System

⚠ Rules for safely connecting the fully automatic oven cleaning system

Getting the ConvoClean and ConvoCare connections mixed up may pose a risk of injury or illness when food cooked afterwards is eaten.

In order to prevent this risk, make sure to observe the following rules:

- When connecting ConvoClean forte and ConvoCare, make absolutely sure that the hoses are connected to the right fitting and the right canister cap.

Prerequisites

Check whether the following prerequisites are met:

- Cold water connection as specified in the Water Supply on page 55 section
- Drain connection as specified in the Water Drain on page 57 section
- Technical prerequisites as specified in the Technical Data on page 70 section

Connecting the Fully Automatic Cleaning System

Follow the steps below to connect the ConvoClean system:

| Step | Procedure |
|------|--|
| 1 | Slip the red suction tube (4) for the cleaning agent onto the barbed nipple on the outer bulkhead fitting (G) and secure the tube using the wire hose clamp (3) (see 'Cleaning agent connection' label at the back of the unit). |
| 2 | Slip the green suction tube (2) for the rinse aid onto the barbed nipple on the inner bulkhead fitting (F) and secure the tube using the wire hose clamp (3) (see 'Rinse aid connection' label at the back of the unit). |
| 3 | Insert the suction nozzle on the red suction tube into the ConvoClean forte canister (5). The tube must be routed without any kinks and the canister's vent opening must be open and clear. |
| 4 | Insert the suction nozzle on the green suction tube into the ConvoCare canister (1). The tube must be routed without any kinks and the canister's vent opening must be open and clear. |
| 5 | Start a cleaning sequence with the 1st setting and check to make sure that cleaning agent is sprayed inside. |

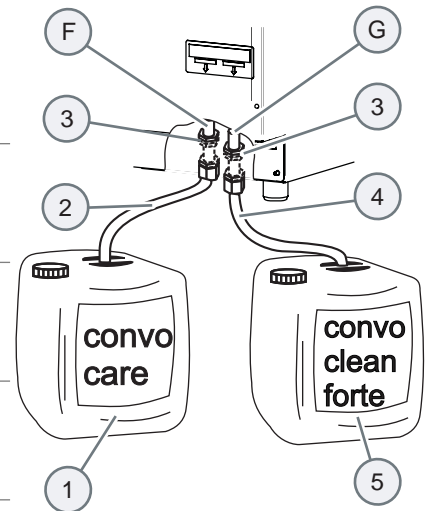

7 Placing into operation

Purpose of this section

This section goes over how to put your combi oven into operation, remove it from service, and dispose of it properly.

7.1 Working Safely When Putting the Unit Into Operation

For your safety when placing the combi oven into operation

Before starting your work, read and understand the hazards described in Hazards and Safety Measures When Placing the Combi Oven into Operation on page 27 and in the 'For Your Safety' section of the operating manual.

Personnel qualifications required for placing the unit into operation

Placing the unit into operation requires work to be performed under unusual operating conditions (e.g., with the safety covers removed) and includes tasks requiring qualifications and unit-specific skills that go beyond the requirements that must be met by the staff operating the unit.

The staff placing the unit into operation must meet the following requirements:

- They are employees working for an authorized customer service company.
- Must have relevant training as service technicians.
- Must have unit-specific training.
- The staff removing the unit from service must especially be able to assess whether the unit's power, water, and drain connections have been correctly installed.

Personal protective equipment

Wear the personal protective equipment specified for your work in the 'Personal Protective Equipment' on page 37 section of 'For Your Safety'.

Basic rules for safe operation

If the combi oven is moved in an impermissible manner after installation (on purpose or by accident), do not continue to operate the unit unless all the following requirements are met:

- The unit and the accessories being used do not have any obvious damage.
- The supply lines installed for electrical power, water, wastewater, and cleaning agents do not have any obvious damage, have a secure fit, are not dripping anywhere, and appear to be safe and fully functional after a visual inspection.
- The 'Requirements concerning the combi oven's functional capability on page 18' are being met.
- The 'Requirements concerning the combi oven's surroundings on page 19' are being met.
- All warning labels are at their intended location.

Rules for safely running the unit

In order to avoid hazards, follow the rules below when running the unit:

- Make sure to only use your hands when using the unit's controls (buttons, switches, touchscreens).
- Do not cover, obstruct, or block the air vent or the dry air intake at the top of the unit, the vents at the back of the unit, or the opening at the front between the feet.
- The racks need to be locked in place.
- Bakeware must be slid in properly; please refer to 'Placing Food Inside and Taking It Out' in the operating manual.
- The suction panel needs to be properly locked in place.

Additional rules for safely running the unit on a moving base

In order to avoid hazards, follow the rules below when running units on a base with casters:

- The retaining element used to limit how much the base can move with the unit must be attached at all times.
Every day before using the unit, check to make sure that the retaining element is attached.
- Make sure to always lock the front casters' wheels when the units are running
- Every day before using the units, check to make sure that casters' wheels are locked

Live parts

▲WARNING

Risk of electric shock posed by live parts and loose cables

Electric shock may occur when coming into contact with live parts after opening the cover.

- ▷ Make sure that all electrical work is performed exclusively by a qualified electrician from an authorized customer service office.
- ▷ Follow the steps below before removing the safety covers:
 - De-energize all connections.
 - Lock out and tag out all switches.
 - If the device was already energized, wait 15 minutes so that the DC bus capacitors can discharge fully.
 - Make sure that the unit is de-energized.
- ▷ Before putting the unit into operation, make sure that all electrical connections are undamaged and firmly connected.
- ▷ Before putting the unit into operation, make sure that it is bonded to an electrical ground system together with all metallic accessories.

Hot surfaces

▲WARNING

Risk of burns posed by high temperatures inside the oven cavity and on the inside of the unit door

Touching any interior oven cavity parts, the inside of the unit door, or any parts that are found inside the cooking compartment during cooking may result in burns.

- ▷ Wear the required personal protective equipment.

Hot steam / vapour

▲CAUTION

Risk of scalding posed by hot steam

Hot steam coming out from the unit may scald your face, hands, feet, and/or legs.

- ▷ When opening the unit door, make sure to always use the cracked-open position as per the instructions on how to safely open the unit door. Do not, under any circumstance, stick your head inside the oven cavity.
- ▷ When cooling down the oven with the Cool down function while the unit door is open, step away from the unit, as hot steam will come out through the door.
- ▷ If you open the unit door while cooling down the oven with the Cool down function, be ready for a rush of hot steam.

Contact with cleaning agents

▲WARNING

Risk of chemical burns and skin, eye, and respiratory tract irritation

The ConvoClean new cleaning agent and the ConvoCare rinse aid will cause skin, eye, and respiratory tract irritation upon direct contact. The ConvoClean forte cleaning agent will result in chemical burns to the skin, eyes, and respiratory tract upon direct contact.

- ▷ Do not inhale the cleaning agents' and rinse aid's vapors or mist.
- ▷ Do not let the cleaning agents or rinse aid come into contact with your eyes, skin, or mucous membranes.
- ▷ Do not spray cleaning agents or rinse aid into a oven cavity that is at a temperature higher than 140°F, as doing so will cause more caustic and/or irritating cleaning-fluid vapors to be produced.
- ▷ Wear the required personal protective equipment.

7.2 Procedure for Placing the Unit into Operation

Meaning

This section is intended to provide commissioning staff with an overview of the prerequisites that must be met before placing the combi oven into operation, as well as with information on how to place it into operation.

Checks before placing the unit into operation

Before putting the combi oven into operation, check whether the prerequisites below are being met:

- The unit does not have any obvious damage.
- The unit has been set up in such a way that it will not shift or topple over; the requirements concerning the location and the unit's surroundings are met (please refer to the Setup on page 40).
- Protective films, cardboard, securing devices for shipping, etc., have been removed completely.
- There is nothing being stored inside the oven cavity and there is nothing inside the oven cavity other than required cooking accessories (bakeware, for example).
- The unit has been installed as per the specifications in the Installation on page 51 section. Conduct this check using the Transportation, Setup, and Installation Checklist.
- The unit has been subjected to an individual electric inspection (see below).
- All safety guards and devices are in their intended place and are working properly. All warning labels are at their intended location. Conduct these checks using the Safety Guards, Safety Devices, and Warning Labels Checklist.

Do not place the unit into operation unless all specified prerequisites are met.

Individual electric inspection

An individual electric inspection includes the following three steps:

- Inspection: Visual inspection for damage and improper use
- Measurement: Measurements performed as per generally accepted standards and practices (equipment grounding conductor resistance, insulation resistance, equipment grounding conductor current / leakage current)
- Testing: Functional test

The individual electric inspection must be repeated at regular intervals as required by law.

Placing into operation

Follow the steps below to put the combi oven into operation:

| Step | Procedure | For more information... |
|------|--|--------------------------------------|
| 1 | Bring the ambient temperature to the permissible operating temperature. | |
| 2 | Turn on the circuit breaker. | |
| 3 | Open the water supply. | |
| 4 | Check to make sure that the following are installed properly in the right position: <ul style="list-style-type: none"> ▪ Suction panel ▪ Racks | Please refer to the operating manual |
| 5 | Turn the combi oven on. | Please refer to the operating manual |
| 6 | Configure the following settings: <ul style="list-style-type: none"> ▪ Date ▪ Time ▪ Language | Please refer to the operating manual |
| 7 | Select the 'Hot steam' cooking program: <ul style="list-style-type: none"> ▪ Set a temperature of 302°F and a duration of 10 minutes. | Please refer to the operating manual |

| Step | Procedure | For more information... |
|------|--|--------------------------------------|
| 8 | Check the following: <ul style="list-style-type: none">▪ Is the oven light on?▪ Is the fan running?▪ Are there any leaks in the wastewater and supply water systems?▪ Is the temperature increasing inside the oven cavity? | |
| 9 | Select the 'Steam' cooking program: <ul style="list-style-type: none">▪ Set a temperature of 212°F and a duration of 10 minutes. | Please refer to the operating manual |
| 10 | Check whether steam is being produced inside the oven (carefully open the door). | |
| 11 | Check the ConvoClean fully automatic cleaning system: <ul style="list-style-type: none">▪ Start the fully automatic cleaning sequence.▪ Check that ConvoClean forte and ConvoCare are being properly supplied. | Please refer to the operating manual |

Briefing the user

Brief the user on all safety-relevant functions, mechanisms, and devices. Show the user how to operate the unit.

8 Removing from Service and Disposal

Purpose of this section

This section goes over how to remove your combi oven from service and dispose of it properly.

8.1 Working Safely When Removing the Unit from Service

For your safety when removing the combi oven from service

Before starting your work, read and understand the hazards described in Hazards and Safety Measures When Removing the Combi Oven from Service on page 30.

Personnel qualifications required for removing the unit from service

Removing the unit from service requires work to be performed under unusual operating conditions (e.g., with the safety covers removed) and includes tasks requiring qualifications and unit-specific skills that go beyond the requirements that must be met by the staff operating the unit.

The staff placing the unit into operation must meet the following requirements:

- They are employees working for an authorized customer service company.
- Must have relevant training as service technicians.
- Must have unit-specific training.
- The staff placing the unit into operation must especially be able to assess whether the unit's power and water connections have been correctly installed.

Personal protective equipment

Wear the personal protective equipment specified for your work in the 'Personal Protective Equipment' on page 37 section of 'For Your Safety'.

Live parts

WARNING

Risk of electric shock posed by live parts and loose cables

Electric shock may occur when coming into contact with live parts after opening the cover.

- ▷ Make sure that all electrical work is performed exclusively by a qualified electrician from an authorized customer service office.
- ▷ Follow the steps below before removing the safety covers:
 - De-energize all connections.
 - Lock out and tag out all switches.
 - Wait 15 minutes so that the DC bus capacitors can discharge fully.
 - Make sure that the unit is de-energized.

Moving heavy loads

WARNING

Risk of injury when lifting loads incorrectly

Lifting the unit incorrectly may result in injury (especially in the area of the torso) due to the unit's weight.

- ▷ Use a forklift, pallet jack, or appropriate lifting equipment to transport the unit.
- ▷ When lifting the unit, make sure to use an appropriate number of people as required by the unit's weight (guideline: 30 lbs to a maximum of 120 lbs depending on age, sex, and build). Comply with all occupational health and safety regulations that apply at the installation location!
- ▷ Wear the required personal protective equipment.

Unsuitable supporting surfaces

▲WARNING

Crush hazard posed by the unit falling down or toppling over

Body parts may be crushed if the unit falls down or topples over.

- ▷ Make sure never to place the unit on an unsuitable supporting surface.

Contact with cleaning agents

▲WARNING

Risk of chemical burns and skin, eye, and respiratory tract irritation

The ConvoClean new cleaning agent and the ConvoCare rinse aid will cause skin, eye, and respiratory tract irritation upon direct contact. The ConvoClean forte cleaning agent will result in chemical burns to the skin, eyes, and respiratory tract upon direct contact.

- ▷ Do not inhale the cleaning agents' and rinse aid's vapors or mist.
- ▷ Do not let the cleaning agents or rinse aid come into contact with your eyes, skin, or mucous membranes.
- ▷ Observe all the instructions and warnings on the cleaning agent labels and in the corresponding safety data sheets when handling cleaning agents.
- ▷ Wear the required personal protective equipment.

8.2 Removing from Service and Disposal

Prerequisites

Check the following before removing the unit from service:

- The unit has been de-energized.
- The water supply has been shut off.

Removing from service

To remove your combi oven from service, undo all setup and installation work step-by-step in opposite order (please refer to the 'Installation on page 51', 'Transportation on page 38', and 'Setup on page 40' sections).

The following work must be done properly in order to remove the unit from service:

- Removing the unit's water connection
- Removing the unit's drain connection
- Removing or disconnecting the electrical connections
- Removing the door lock
- Properly disposing of all cleaning agents as indicated in the corresponding safety data sheets and the labels on the cleaning agent containers

9 Technical Data and Connection Drawing

9.1 Technical data

Dimensions and weights

The following table lists the various dimensions and weights:

| Dimensions and weights | | |
|-------------------------|-------|------|
| Width | | |
| With packaging | [in] | 22.8 |
| Without packaging | [in] | 20.3 |
| Depth | | |
| With packaging | [in] | 35.8 |
| Without packaging | [in] | 30.6 |
| Height | | |
| With packaging | [in] | 32.7 |
| Without packaging | [in] | 28.4 |
| Weight | | |
| With packaging | [lbs] | 150 |
| Without packaging | [lbs] | 121 |
| Safety clearances | | |
| Rear | [in] | 2.0 |
| Right-hand side | [in] | 2.0 |
| Left-hand side | [in] | 2.0 |
| Above (for ventilation) | [in] | 20.0 |

Equipment stand dimensions and weights

The following table shows the dimensions of the equipment stands for the combi oven, as well as the total height with the stand:

| | | Open equipment stand |
|-----------------------------------|-------|----------------------|
| Width | [in] | 20.3 |
| Depth | [in] | 25.7 |
| Height | [in] | 35.4 |
| Weight | [lbs] | 27 |
| Total height with equipment stand | [in] | 63.9 |

Maximum permissible loading weight

The following table lists the maximum permissible loading weight for each combi oven. These values apply under the condition that the weight loaded onto each shelf does not exceed 11 lbs:

| Maximum permissible loading weight | | |
|---|-------|----|
| Standard size bakeware (containers, oven racks, sheet pans) | | |
| Per combi oven | [lbs] | 44 |
| Per shelf | [lbs] | 11 |

Electrical ratings

The following table lists the various electrical rating specifications:

| Electrical ratings | | |
|--|------|-------------------|
| 3~ 208V-240V 60Hz (3/PE) | | |
| Rated power consumption | [kW] | 5.65 |
| Hot air output (RHK rated output) | [kW] | 5.58 |
| Motor output | [kW] | 0.25 |
| Rated current | [A] | 15.7 |
| Supplied with a 4 conductor 6 foot long cord | AWG | 10 |
| Conductor insulation rating | | SOOW |
| Plug (customer supplied) | NEMA | 15-50P or L15-50P |
| 3~ 208V-240V 60Hz (3/PE) | | |
| Rated power consumption | [kW] | 7.45 |
| Hot air output (RHK rated output) | [kW] | 7.40 |
| Motor output | [kW] | 0.25 |
| Rated current | [A] | 17.9 |
| Supplied with a 4 conductor 6 foot long cord | AWG | 10 |
| Conductor insulation rating | | SOOW |
| Plug (customer supplied) | NEMA | 15-50P or L15-50P |

Heat loss

The following table lists the various heat loss specifications:

| Heat loss | | |
|------------------|---------|------|
| Latent | [BTU/h] | 1263 |
| Sensible | [BTU/h] | 1365 |

Water connection

The following table lists the specifications for the water connection:

| Water connection | | |
|--------------------------|-------|---|
| Water supply (cold only) | | |
| Shut-off device | | The unit may need to be installed with an appropriate backflow preventer in order to comply with all applicable federal, state, and local laws and regulations. |
| Water supply | | |
| Connection | | Two 3/4" inner diameter GHT-M (garden hose adapter). The unit is designed for a permanent hookup to the water supply that uses a connecting hose with a minimum diameter of 1/2" |
| Flow pressure | [psi] | 43.5 - 87 psi (3 - 6 bar) |
| Water drain | | |
| Version | | Naturally ventilated pipe to open pan or drain/channel, min. 1" ventilation clearance |
| Type | [in] | Depending on the length of the line and the elements used in the line, the minimum inner diameter of the line is 1.5". |

Water quality

The following table lists water quality specifications:

| Water hardness for water injection | | |
|---|-------|---|
| Water quality | | Drinking water Soft water |
| Hardness | [ppm] | 70 - 125 (4 - 7 gpg) |
| TDS (total dissolved solids) | [ppm] | 70 - 125 |
| Total alkalinity | [ppm] | 50 - 100 |
| Water hardness for cleaning | | |
| Water quality | | Drinking water Hard water (or soft water; see above for specification) |
| Hardness | [ppm] | 70 - 360 (4 - 21 gpg) |
| TDS (total dissolved solids) | [ppm] | 70 - 360 |
| Total alkalinity | [ppm] | 50 - 100 |
| Figures | | |
| Temperature | [°F] | max. 104 |
| pH value | | 6.5 - 8.5 |
| Cl ⁻ (chloride) | [ppm] | max. 60 |
| Cl ₂ (free chlorine) | [ppm] | max. 0.2 |
| SO ₄ ²⁻ (sulfate) | [ppm] | max. 150 |
| Fe (iron) | [ppm] | max. 0.1 |
| SiO ₂ (silicate) | [ppm] | max. 13 |

Water consumption

The following table lists the combi oven's water consumption values:

| Water consumption | | |
|---|-------|---------|
| Cold water | | |
| Average water consumption | [gph] | 0 - 5.3 |
| Peak consumption | [gpm] | 2.6 |
| Soft water | | |
| Average water consumption for sizing the water filter | [gph] | 0 - 4.0 |

Unit specifications

The following table lists the various unit specifications:

| Unit specifications | | |
|---|-------|---------|
| Protection rating | | IPX4 |
| Conformity/certification marks in accordance with the applicable country-specific regulations | | UL, NSF |
| Noise emissions | | |
| Measured | [dBA] | max. 60 |

9.2 Connection drawing

OES 10.10 mini dimensions and connection points

The following table shows the various dimensions and connection points:

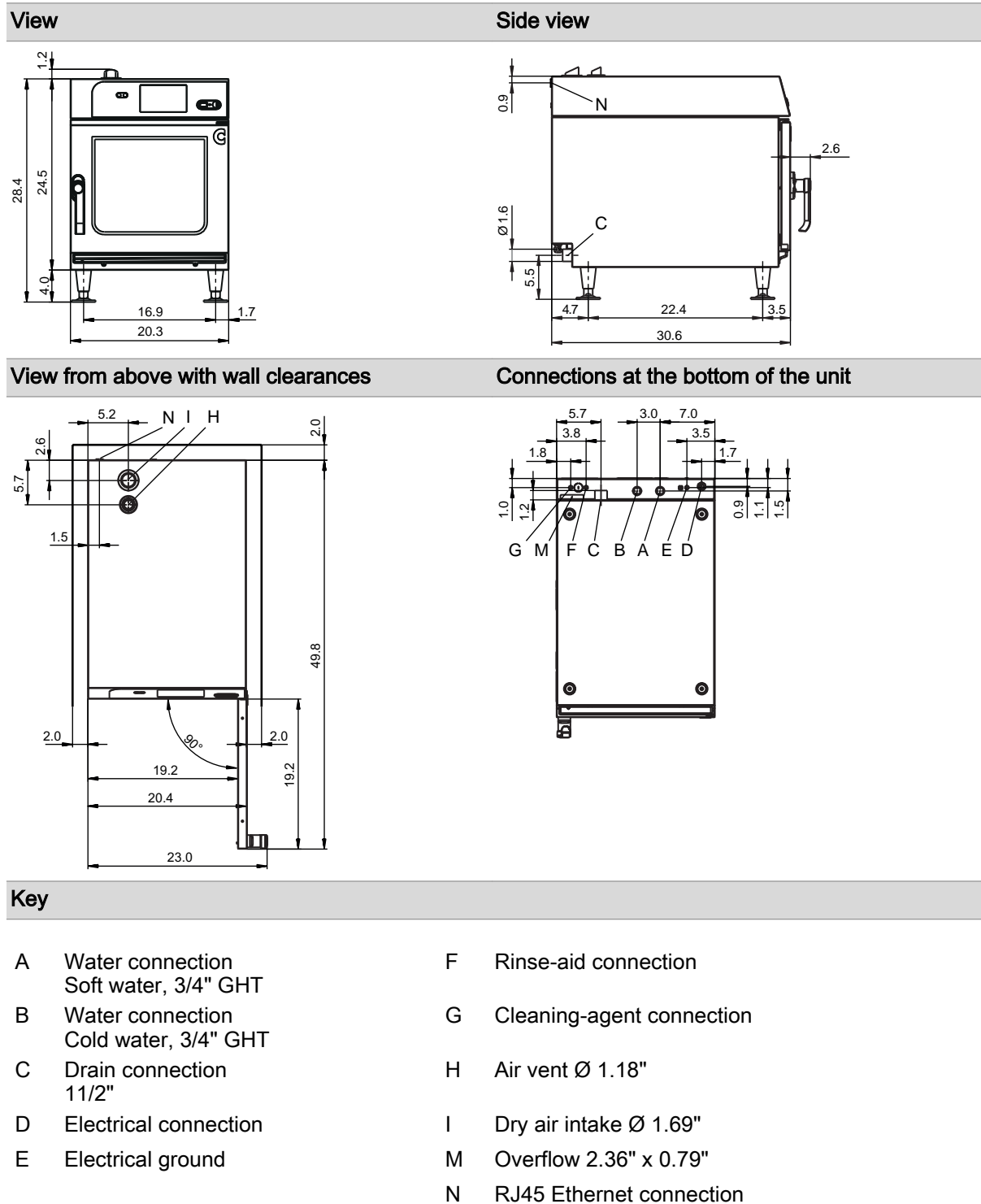

Combi Oven OES 6.10 mini easyTouch

Serial No.

Item no.

Order No.

Additional technical documentation can be found in the download center at :
www.convotherm.com



Welbilt offers fully-integrated kitchen systems and our products are backed by KitchenCare® aftermarket parts and service. Welbilt's portfolio of award-winning brands includes **Cleveland™**, **Convotherm®**, **Delfield®**, **fitkitchenSM**, **Frymaster®**, **Garland®**, **Kolpak®**, **Lincoln™**, **Manitowoc®**, **Merco®**, **Merrychef®** and **Multiplex®**.

Bringing innovation to the table • welbilt.com



Combi Oven

OES 10.10 mini easyTouch

Installation manual UL, USA - Original, ENG

FOR THE INSTALLER, OPERATOR, RESPONSIBLE OWNER

FOR YOUR SAFETY

Do not store or use gasoline or other flammable vapors or liquids in the vicinity of this or any other unit.



WARNING

Improper installation, adjustment, alteration, service or maintenance can cause property damage, injury and death. Read the installation, operating and maintenance instructions thoroughly before installing or servicing this equipment.



WARNING

To reduce the risk of electric shock, do not remove or open cover. No user serviceable parts inside. Refer servicing to qualified personnel. Disconnect power supply before servicing.



WARNING

Disconnect power at the main external power switch before servicing or repairing a combi oven.

IMPORTANT

ALL SERVICE MUST BE PERFORMED BY A QUALIFIED CONVOTHERM AUTHORIZED TECHNICIAN.

KEEP AREA FREE AND CLEAR OF COMBUSTIBLES.

Installation

- Installation of this unit must be done by a licensed professional when installed in the Commonwealth of Massachusetts.
- The wiring diagram is located on the inner part of the side panel.

Customer documentation

- The customer documentation is part of the combi oven.
- Keep the customer documentation manuals handy at all times so that you can look up any required information.
- Keep the customer documentation manuals for the entire life of the unit.
- Carefully read the installation manual, the operating manual, and the operating instructions before using, handling, and working on this unit.
- If you transfer the combi oven to a new owner, make sure to give the new owner the customer documentation manuals as well.

Table of Contents

| | | |
|----------|--|-----------|
| 1 | General | 7 |
| 1.1 | Environmental Protection | 7 |
| 1.2 | Identifying Your Combi Oven | 8 |
| 1.3 | Customer Documentation Structure | 9 |
| 1.4 | Safety Information That Must Be Read without Exception | 10 |
| 1.5 | About This Installation Manual | 11 |
| 2 | Configuration and Functions | 13 |
| 2.1 | The Combi Oven's Configuration and Functions | 13 |
| 2.2 | Control Panel Layout and Functions | 14 |
| 3 | For Your Safety | 15 |
| 3.1 | Basic Safety Instructions | 15 |
| 3.2 | Your Combi Oven's Intended Use | 17 |
| 3.3 | Warning Labels on the Combi Oven | 19 |
| 3.4 | Hazards and Safety Measures When Moving the Unit | 21 |
| 3.5 | Hazards and Safety Measures During Setup | 22 |
| 3.6 | Hazards and Safety Measures During Installation | 24 |
| 3.7 | Hazards and Safety Measures When Putting the Unit into Operation | 26 |
| 3.8 | Hazards and Safety Measures When Removing the Unit from Service | 29 |
| 3.9 | Safety Devices | 32 |
| 3.10 | Staff and Work Area Requirements | 33 |
| 3.11 | Personal protective equipment | 35 |
| 4 | Transportation | 36 |
| 4.1 | Working Safely During Transportation | 36 |
| 4.2 | Transporting the unit to the installation location | 37 |
| 5 | Setup | 38 |
| 5.1 | Working Safely During Setup | 38 |
| 5.2 | Adjacent Systems | 40 |
| 5.3 | Installation location requirements | 41 |
| 5.4 | Unpacking | 44 |
| 5.5 | Removing the unit from the pallet | 46 |
| 5.6 | Setting up the unit on a work table | 47 |
| 5.7 | Setting Up the Unit on a Stand | 48 |
| 6 | Installation | 50 |
| 6.1 | Electrical installation | 50 |
| 6.1.1 | Working Safely When Installing the Electrical Installation | 50 |
| 6.1.2 | Planning the Electrical Installation | 51 |
| 6.1.3 | Performing the Electrical Installation | 52 |
| 6.2 | Water connection | 53 |
| 6.2.1 | Working Safely When Setting Up the Water Connection | 53 |
| 6.2.2 | Water supply | 54 |
| 6.2.3 | Water drain | 56 |
| 6.3 | ConvoClean System Installation | 58 |
| 6.3.1 | Working Safely When Installing the ConvoClean System | 58 |
| 6.3.2 | Components of Fully Automatic Oven Cleaning System | 59 |
| 6.3.3 | Connecting the Fully Automatic Cleaning System | 60 |

| | | |
|----------|---|-----------|
| 7 | Placing into operation | 61 |
| 7.1 | Working Safely When Putting the Unit Into Operation | 61 |
| 7.2 | Procedure for Placing the Unit into Operation | 63 |
| 8 | Removing from Service and Disposal | 65 |
| 8.1 | Working Safely When Removing the Unit from Service | 65 |
| 8.2 | Removing from Service and Disposal | 67 |
| 9 | Technical Data and Connection Drawing | 68 |
| 9.1 | Technical data | 68 |
| 9.2 | Connection drawing | 71 |

1 General

Purpose of this section

This section provides information on how to identify your combi oven and how to use this manual.

1.1 Environmental Protection

Policy statement

Our customers' expectations, the legal regulations and standards we have to follow, and our company's reputation are what drives the quality and service behind all our products.

Our environmental management policy is not only designed to ensure that we are always in full compliance with all environmental laws and regulations, but also reflects our commitment to the environment and to continuously improving our performance in this field.

In order to ensure that we meet all of our environmental goals while maintaining the high quality of our products, and that things stay this way, we have developed a quality and environmental management system.

This system meets the requirements set forth in ISO 9001:2008 and ISO 14001:2004.

Environmental protection measures

The following measures apply to this product:

- Uses fully compostable packing products
- Uses RoHS-compliant products
- Complies with the REACH regulation
- Shipping boxes are reused
- Recommends and uses biodegradable cleaning agents
- E-waste recycling
- Environmentally friendly disposal of old units

Join us in our commitment to protecting the environment!

1.3 Customer Documentation Structure

Customer documentation parts

The customer documentation for the combi oven is made up of the following:

- Installation manual (this manual)
- Operating manual
- Operating instructions for easyStart mode
- Help pages integrated into the software (excerpt from the operating manual)

Customer Documentation Structure

The following table outlines how the customer documentation is structured:

| Subject | Description | Please refer to |
|-----------------------------------|--|--|
| Transportation | Transporting the combi oven | Installation manual |
| Setup | <ul style="list-style-type: none"> ▪ Setup options ▪ Correctly setting up the combi oven | (intended for trained qualified personnel; see Staff Requirements) |
| Installation | <ul style="list-style-type: none"> ▪ Electrical connection ▪ Water connection ▪ Installing the ConvoClean fully automatic cleaning system | |
| Placing into operation | Combi oven initial startup | |
| Operation | <ul style="list-style-type: none"> ▪ User interface explanation ▪ Work sequences and steps | Operating manual |
| Cleaning | <ul style="list-style-type: none"> ▪ Cleaning schedule ▪ Cleaning programs and tasks | (intended for briefed staff and trained qualified staff; see Staff Requirements) |
| Maintenance | <ul style="list-style-type: none"> ▪ Maintenance Schedule ▪ limited maintenance work | |
| Removing from service | Removing the combi oven from service | Installation manual |
| Technical data | <ul style="list-style-type: none"> ▪ Shelf options ▪ max. loading weight | Operating manual |
| | All the technical data for the combi oven | Installation manual |
| Scale drawings, connection points | All the scale drawings and connection points for the combi oven | Installation manual |
| Checklists | Installation checklists | |

1.4 Safety Information That Must Be Read without Exception

Safety information found in the documentation for the customer

The most important safety information for the combi oven is essentially found in the installation manual and operating manual.

The installation manual provides safety information for the transportation, setup, installation, placing-into-operation, and removal-from-service tasks it describes.

The operating manual provides safety information for the cooking, cleaning, and maintenance tasks it describes.

When using the operating instructions, the operating manual or installation manual should always be consulted in order to obtain the relevant safety information. When performing activities that go beyond simply using the software, the safety information in the operating manual and installation manual must always be observed.

Parts of this document that must be read without exception

Failure to take the information in this document into account may result in death, injury, or property damage.

In order to ensure their safety and the safety of others, everyone working with/on the combi oven must read and understand the following parts of this document before starting any work:

- The 'For Your Safety' section; please refer to For Your Safety on page 15
- The sections describing the work that will be carried out



Danger symbol

| Danger symbol | Meaning |
|---|---|
|  | Used to warn of potential injury. Observe all the precautionary statements following this symbol in order to avoid injury or death. |



Precautionary statements

The precautionary statements in this manual are categorized using the following hazard levels:

| Hazard level | Consequences | Likelihood |
|--|--------------------------------------|------------|
|  DANGER | Death / severe injury (irreversible) | Imminent |
|  WARNING | Death / severe injury (irreversible) | Potential |
|  CAUTION | Minor injury (reversible) | Potential |
| NOTICE | Property damage | Potential |

1.5 About This Installation Manual

Purpose

The purpose of this installation manual is to provide everyone working with/on the combi oven with the information they will need to transport, set up, install, and place the unit into operation safely and correctly.

Target groups

This installation manual is intended for the following target groups:

| Name of target group | Tasks |
|----------------------|---|
| Mover | Transporting the unit within the facilities |
| Service technician | <ul style="list-style-type: none"> ▪ Setting up the unit ▪ Installing and uninstalling the water connection ▪ Installing the ConvoClean fully automatic cleaning system ▪ Placing the unit into operation and removing it from service ▪ Briefing the user |
| Electrician | Installing and uninstalling electrical connections |

Installation manual outline

The following table describes the contents and goals for the various sections in this manual:

| Contents | Purpose |
|--|--|
| General | <ul style="list-style-type: none"> ▪ Helps identify your combi oven ▪ Explains how to use this installation manual |
| Configuration and Functions | <ul style="list-style-type: none"> ▪ Describes the combi oven's intended use ▪ Explains the combi oven's functions and describes where its components are located |
| For Your Safety | Describes all the risks and hazards posed by the combi oven, as well as appropriate instructions on how to prevent and/or counter them Read this section carefully! |
| Transportation | <ul style="list-style-type: none"> ▪ Provides basic unit dimensions ▪ Provides information on the requirements concerning the installation location ▪ Explains how to transport the unit to its installation location |
| Setup | <ul style="list-style-type: none"> ▪ Explains how to unpack the unit and goes over the included equipment and parts ▪ Explains how to set up the combi oven |
| Installation | Explains how to install: <ul style="list-style-type: none"> ▪ Electrical connection ▪ Water connection ▪ ConvoClean fully automatic cleaning system |
| Placing into operation | Explains how to put the unit into operation |
| Removing from Service, Disposal | <ul style="list-style-type: none"> ▪ Explains how to remove the unit from service ▪ Provides disposal information |
| Technical data | Contains technical specifications |
| Scale drawings and connection diagrams | Contains scale drawings and connection diagrams |

Decimal mark used

In order to ensure that all numbers can be properly understood internationally, a decimal point is always used.

2 Configuration and Functions

Purpose of this section

This section describes the combi oven's configuration and explains its functions.

2.1 The Combi Oven's Configuration and Functions

Combi oven's configuration

The following figure illustrates the combi oven:

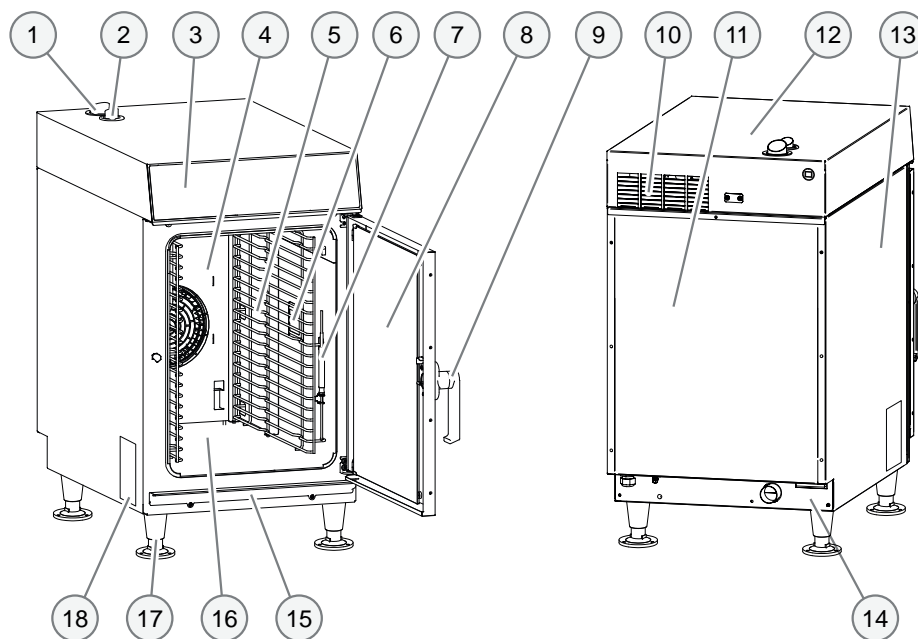

Material

The combi oven's inner and outer parts are made of stainless steel.

2.2 Control Panel Layout and Functions

Control panel layout

The figure below shows the control panel:

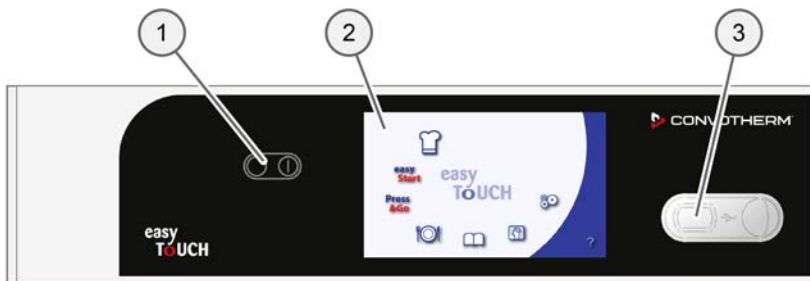

Control panel parts

Following is an explanation of what the control panel's parts do:

| No. | Designation | Function |
|-----|-------------|--|
| 1 | Main switch | Used to turn the combi oven on and off |
| 2 | Touchscreen | Central combi oven controls <ul style="list-style-type: none"> ▪ Used by touching the icons on the touchscreen ▪ Status indicators |
| 3 | USB port | Used to connect external devices |

3 For Your Safety

Purpose of this section

The purpose of this section is to provide you with all the information you will need in order to safely work with/on the combi oven without putting yourself and others at risk.

Read this section very carefully!

3.1 Basic Safety Instructions

Purpose of these instructions

The purpose of these instructions is to ensure that everyone working with and on the combi oven will be fully aware of all the risks, hazards, and safety requirements involved and will observe the warnings in the operating manual and on the combi oven. Failure to follow these instructions may result in death, injury, or property damage.

Customer documentation manuals

Follow the instructions below:

- Fully read the 'For Your Safety' section, as well as the section that applies to the way you will be interacting with the combi oven.
- Keep the customer documentation manuals handy at all times so that you can look up any required information.
- If you transfer the combi oven to a new owner, make sure to give the new owner the customer documentation manuals as well.

Basic rules for installation

The unit must be installed in compliance with all national and state laws and regulations, with all applicable local requirements and regulations set forth by the relevant local utility companies and authorities, and with all other relevant regulations and standards.

These include, but are not limited to:

- The National Electrical Code, ANSI/NFPA 70 (current edition)
- The Canadian Electrical Code, CSA C22.2
- The Food Code and Food Service Sanitation Manual published by the Food and Drug Administration (FDA) (current editions)
- Latest edition of the International Plumbing Code published by the International Code Council (ICC) or the Uniform Plumbing Code published by the International Association of Plumbing and Mechanical Officials (IAPMO)
- The standards published by the National Sanitation Foundation (NSF)
- All local fire protection and occupational health and safety regulations

Working with/on the combi oven

Follow the instructions below:

- Only people who meet all the requirements specified in this operating manual should be allowed to use and otherwise work with/on the combi oven.
- Only use the combi oven for its intended use as described in this manual. Never, under any circumstance, use the combi oven for other purposes, even if they seem obvious.
- Observe all the safety measures specified in this operating manual and on the combi oven. This applies especially to wearing the required personal protective equipment.
- Make sure to always stay in the specified work areas when working with/on the combi oven.
- Do not make any alterations to the combi oven. This includes removing components and adding components that have not been expressly approved. Above all, however, make sure not to disable any safety devices or guards.

For more information...

Related subjects

| | |
|--|----|
| ▷ Your Combi Oven's Intended Use | 17 |
| ▷ Warning Labels on the Combi Oven | 19 |
| ▷ Hazards and Safety Measures When Moving the Unit | 21 |
| ▷ Hazards and Safety Measures During Setup | 22 |
| ▷ Hazards and Safety Measures During Installation | 24 |
| ▷ Hazards and Safety Measures When Putting the Unit into Operation | 26 |
| ▷ Hazards and Safety Measures When Removing the Unit from Service | 29 |
| ▷ Safety Devices | 32 |

3.2 Your Combi Oven's Intended Use

The combi oven's intended use

- The combi oven has been designed and built exclusively for cooking a variety of food in standard-size bakeware (steam table pans, sheet pans, etc.). Steam, convection, and combi-steam (steam superheated without pressure) are used for this purpose.
- The bakeware can be made of stainless steel, ceramic, plastic, aluminum, enameled steel, or glass. Glass bakeware must not be damaged.
- The combi oven is intended exclusively for professional commercial use.

Ventilation

The combi oven is a commercial combination oven with integral systems for limiting the emission of grease laden air.

This unit is UL category KNLZ listed for ventless operation. Allows operators to expand into new non-traditional outlets. Local codes prevail as stated in NFPA 96-1994 regulations.

The combi oven may need a hood to satisfy state and local codes. Check your local codes for requirements.

Limitations on use

The combi oven should not be used to heat up the following materials:

- Dry powders or granular products
- Readily flammable substances or objects with a flashpoint lower than 518°F, such as readily flammable oils, fats, and plastics
- Food in sealed cans

Staff requirements

- The combi oven must be run and installed exclusively by staff meeting the specified requirements. For the corresponding training and qualifications requirements, please refer to 'Staff and Work Area Requirements' on page 33.
- All staff must be familiar with the risks, hazards, and rules involved in handling heavy loads.

Requirements concerning the combi oven's functional capability

- Do not operate the combi oven unless it has been properly transported, set up, installed, and placed into operation as indicated in the installation manual and the person responsible for placing it into operation has confirmed this.
- The combi oven should only be used if all safety devices and guards are present, working properly, and correctly locked in place.
- All manufacturer specifications concerning how to run and service the combi oven must be observed.
- The load placed inside the combi oven must never exceed the maximum permissible loading weight; please refer to 'Technical Data' on page 68.

Requirements concerning the combi oven's surroundings

Required combi oven surroundings

- Ambient temperature between 40°F and 95°F
- No toxic or potentially explosive atmospheres
- Do not use or store gasoline or other flammable vapors, gases, or liquids in the vicinity of a combi oven
- Dry kitchen floor in order to reduce the risk of accidents occurring

Required installation location characteristics

- NO fire alarms or sprinkler system directly above the unit
- NO flammable materials, gases, or liquids above, on, under, or close to the unit

Limitations on use

- When used outdoors, the unit must be protected from rain and wind
- Do NOT shift or move the unit during operation

Prerequisites for cleaning

- Only use the cleaning agents approved by the manufacturer.
- Do NOT use a pressure washer to clean the unit.
- Do NOT use a water jet to clean the outside of the unit. Do not use a water jet for anything other than cleaning the oven cavity.
- Do NOT use bases or acids to clean the combi oven and make sure it is not exposed to acid fumes. The only exception is when the oven cavity and the boiler are descaled by an authorized service company following the manufacturer's instructions.

3.3 Warning Labels on the Combi Oven



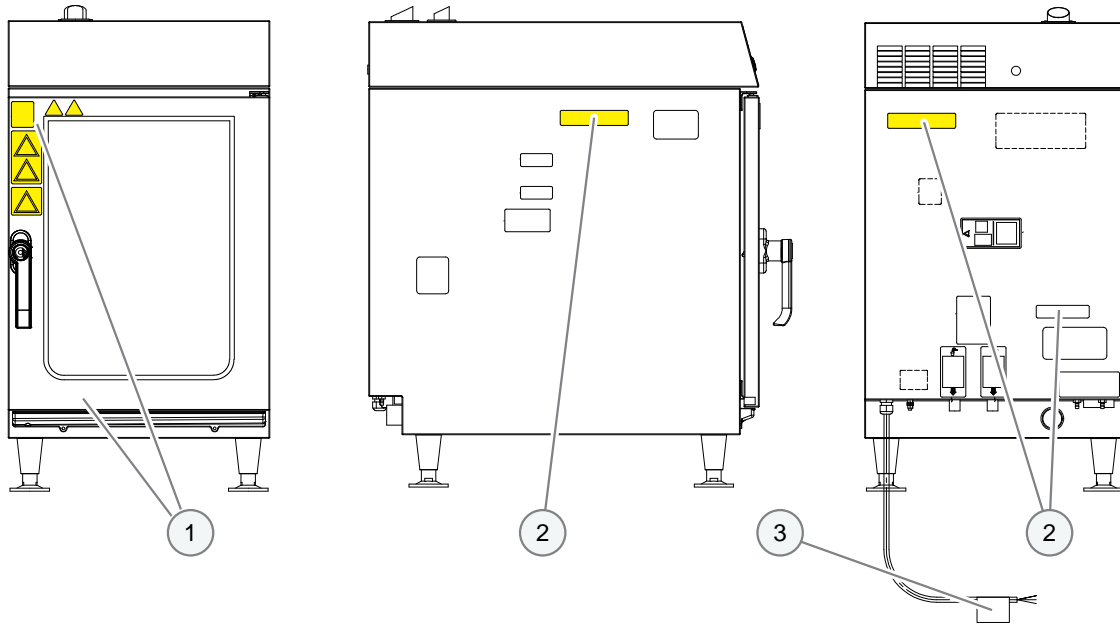

Warning label locations

The warning labels are found at the following locations on the combi oven:



Warning labels on unit door

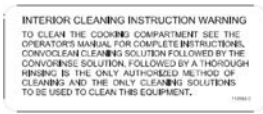

The following warning labels (1) are located on the unit door:

| Warning | Description |
|---|---|
|  | <p>Hot food, hot bakeware, and hot liquid warning Hot food and hot bakeware will pose a burn hazard if the bakeware falls off the shelf levels or if food slides off bakeware that is being held in an inclined position. This hazard will be particularly acute in the case of shelf levels located above the operator's field of view. Risk of scalding when liquid food is spilled. This hazard exists when liquids, or food that becomes liquefied during cooking, are placed on the upper shelf levels. Do not use shelf levels located above your field of view for liquids or food that will become liquefied.</p> |
|  | <p>Hot steam warning There is a risk of scalding posed by the hot steam coming out when the unit door is opened.</p> |
|  | <p>Caustic cleaning agent warning Skin, eye, and respiratory tract irritation hazard posed as a result of contact with cleaning agents, as well as their vapors, if the unit door is opened during fully automatic cleaning (ConvoClean system).</p> |
|  | <p>Only if using a moving base Combi oven tip-over hazard warning There is a risk of the combi oven toppling over when being moved. Exercise extreme caution when moving the combi oven.</p> |
|  | <p>Only if using a moving base Unit hookup damage and disconnection warning There is a risk of the unit's hookups being damaged or disconnected when the combi oven is moved. Exercise extreme caution when moving the combi oven and take the connections' length into account. Every time after moving it, secure the combi oven so that it cannot roll away by accident.</p> |

| Warning | Description |
|---|--|
|  | <p>CAUTION Surface(s) and Handle(s) may be hot.</p> <p>ATTENTION Surface(s) et poignée(s) chaudes</p> |
|  | <p>INTERIOR CLEANING INSTRUCTION WARNING</p> <p>To clean the cooking compartment see the operator's manual for complete instructions. ConvoClean cleaning solutions followed by the ConvoRinse solution. Followed by a thorough rinsing is the only authorized method of cleaning and the only cleaning solutions to be used to clean this equipment.</p> |

Warning labels on combi oven case

The following warning labels (2) are located on the combi oven's case:

| Warning | Description |
|---|--|
|  | <p>WARNING</p> <p>To reduce the risk of electric shock, do not remove or open cover. No user serviceable parts inside. Refer servicing to qualified personnel. Disconnect power supply before servicing.</p> |
|  | <p>AVERTISSEMENT</p> <p>Afin de réduire le risque d'électrocution, ne pas retirer ou ouvrir le capot. Aucune pièce réparable ne se trouve à l'intérieur. Confier le dépannage à du personnel qualifié. Débrancher l'alimentation électrique avant réparation.</p> |
|  | <p>CAUTION</p> <p>Before commencing plumbing installation refer to installation instruction furnished with unit. DO NOT INSTALL a SHUTOFF ON DRAIN OUTLET</p> |

Warning labels on power cord

The following warning labels (3) are located along the power cord:

| Warning | Description |
|---|---|
|  | <p>WARNING</p> <p>Risk of Fire. Use only a UL listed grounding type attachment plug rated for:</p> <ul style="list-style-type: none"> 208-240 V, 30 AMP Minimum, 3 PH, 4 Wire 208-240 V, 50 AMP Minimum, 3 PH, 4 Wire <p>The plug is to be selected and installed only by qualified service personnel or electricians.</p> |

3.4 Hazards and Safety Measures When Moving the Unit

Safety hazard: moving heavy loads

When moving or transporting the unit, keep the following hazards in mind and take the actions required in order to eliminate and/or minimize these hazards:

| Risk / hazard | Where and in which situations will the risk/hazard exist? | What to do | Safety device |
|--|---|--|---------------|
| Risk of injury due to excessive exertion | Whenever moving the unit | <ul style="list-style-type: none"> ▪ Use appropriate lifting equipment ▪ Do not lift or carry too much weight! ▪ Use carrying straps ▪ Wear the required personal protective equipment | None |

Safety hazard: mechanical unit components

When moving or transporting the unit, keep the following hazards in mind and take the actions required in order to eliminate and/or minimize these hazards:

| Risk / hazard | Where and in which situations will the risk/hazard exist? | What to do | Safety device |
|--|---|---|---------------|
| Crush hazard for all body parts if the unit falls down | Whenever moving the unit | <ul style="list-style-type: none"> ▪ Use appropriate transportation equipment ▪ Transport equipment slowly and carefully and secure it in such a way that it cannot tip over ▪ Keep the unit's center of gravity in mind ▪ Avoid bumping into objects | None |
| Crush hazard for all body parts if the unit falls down or topples over | When setting the unit down on the surface on which it will be resting | Observe all the requirements concerning the supporting surface at all times while setting up the unit. Please refer to Installation Location Requirements on page 41 | None |

3.5 Hazards and Safety Measures During Setup

Safety hazard: moving heavy loads

When setting up the unit, keep the following hazards in mind and take the actions required in order to eliminate and/or minimize these hazards:

| Risk / hazard | Where and in which situations will the risk/hazard exist? | What to do | Safety device |
|--|---|---|---------------|
| Risk of injury due to excessive exertion | Whenever moving the unit | <ul style="list-style-type: none"> ▪ Use appropriate lifting equipment when placing the unit on a work table or equipment stand or in a stacking kit ▪ Make sure that a sufficient number of people help correct the unit's position; do not lift or carry too much weight during the process! ▪ Comply with all occupational health and safety regulations that apply at the installation location ▪ Use carrying straps when removing the unit from the pallet ▪ Wear the required personal protective equipment | None |

Safety hazard: mechanical unit components

When setting up the unit, keep the following hazards in mind and take the actions required in order to eliminate and/or minimize these hazards:

| Risk / hazard | Where and in which situations will the risk/hazard exist? | What to do | Safety device |
|---|--|--|--|
| Crush hazard for all body parts if the unit falls down | When lifting the unit | <ul style="list-style-type: none"> ▪ Keep the unit's center of gravity in mind ▪ Avoid bumping into objects | None |
| Crush hazard posed by a loss of unit stability if the unit is set up in a stacking kit or on an equipment stand | <ul style="list-style-type: none"> ▪ When setting up the unit on an equipment stand ▪ When setting up the unit in a stacking kit ▪ If the top is subjected to a heavy uneven load | <ul style="list-style-type: none"> ▪ Do not, under any circumstance, subject the units to additional loads (on the open unit door, for example) ▪ Always set up the bottom unit in the stacking kit first ▪ Before placing the units in a stacking kit with casters, lock the casters' wheels ▪ Make sure that the devices are properly set up inside the stacking kit | Brake and swivel lock when using a stacking kit with casters |
| Crush hazard for all body parts if the unit falls down or topples over | When setting up the unit on the surface on which it will be resting | Observe all the requirements concerning the supporting surface at all times while setting up the unit. Please refer to Installation Location Requirements on page 41 | None |
| Cut hazard posed by sharp edges | Whenever handling sheet metal parts | <ul style="list-style-type: none"> ▪ Exercise caution when performing these activities ▪ Wear the required personal protective equipment as indicated in the relevant safety instructions | None |

3.6 Hazards and Safety Measures During Installation

Safety hazard: electricity

When installing the unit, keep the following hazards in mind and take the actions required in order to eliminate and/or minimize these hazards:

| Risk / hazard | Where and in which situations will the risk/hazard exist? | What to do | Safety device |
|--|--|--|----------------|
| Risk of electric shock posed by live parts | <ul style="list-style-type: none"> ▪ Under covers ▪ Under the operating panel ▪ All along the power cord | <ul style="list-style-type: none"> ▪ Work on the unit's electrical components should be performed exclusively by a qualified electrician from an authorized service company ▪ Work professionally | Covers |
| | | Before removing the covers: <ul style="list-style-type: none"> ▪ De-energize all connections ▪ Lock out and tag out all switches ▪ If the device was already energized, wait 15 minutes so that the DC bus capacitors can discharge fully. ▪ Make sure that the unit is de-energized | Covers |
| | | <ul style="list-style-type: none"> ▪ Before putting the unit into operation, make sure that all electrical connections are undamaged and properly connected | Covers |
| Risk of electric shock posed by live parts | <ul style="list-style-type: none"> ▪ On the unit and on neighboring metal parts ▪ On the unit and on neighboring metal accessories | <ul style="list-style-type: none"> ▪ Before putting the unit into operation, make sure that it is bonded to an electrical ground system together with all metal accessories | Bonding system |
| Risk of electric shock due to bad water connection | <ul style="list-style-type: none"> ▪ In the entire work area as soon as the water hose bursts or starts leaking | <ul style="list-style-type: none"> ▪ Use a fixed connection ▪ Make sure that the water supply's water pressure is compatible with the pressure specified on the unit ▪ Use appropriate hoses as per the applicable requirements | none |

Safety hazard: mechanical unit components

When installing the unit, keep the following hazards in mind and take the actions required in order to eliminate and/or minimize these hazards:

| Risk / hazard | Where and in which situations will the risk/hazard exist? | What to do | Safety device |
|---------------------------------|---|---|---------------|
| Cut hazard posed by sharp edges | Whenever handling sheet metal parts | <ul style="list-style-type: none"> ▪ Exercise caution when performing these activities ▪ Wear the required personal protective equipment as indicated in the relevant safety instructions | None |

Safety hazard: cleaning agents

When installing the unit, keep the following hazards in mind and take the actions required in order to eliminate and/or minimize these hazards:

| Risk / hazard | Where and in which situations will the risk/hazard exist? | What to do | Safety device |
|---|---|--|---------------|
| Skin, eye, and respiratory tract irritation hazard as a result of contact with cleaning agents and their vapors | When installing the cleaning system | <ul style="list-style-type: none"> ▪ Wear the required personal protective equipment ▪ Observe the instructions and warnings on the cleaning agent labels and in the relevant safety data sheets | None |
| | Whenever using aggressive cleaning agents | Only use the cleaning agents specified in the 'Cleaning and maintenance' section of the operating manual (under 'Cleaning agents'). | None |

3.7 Hazards and Safety Measures When Putting the Unit into Operation

Safety hazard: electricity

When putting the unit into operation, keep the following hazards in mind and take the actions required in order to eliminate and/or minimize these hazards:

| Risk / hazard | Where and in which situations will the risk/hazard exist? | What to do | Safety device |
|--|--|--|----------------|
| Risk of electric shock posed by live parts | <ul style="list-style-type: none"> ▪ Under covers ▪ Under the operating panel ▪ All along the power cord | <ul style="list-style-type: none"> ▪ Work on the unit's electrical components should be performed exclusively by a qualified electrician from an authorized service company ▪ Work professionally | Covers |
| | | Before removing the covers: <ul style="list-style-type: none"> ▪ De-energize all connections ▪ Lock out and tag out all switches ▪ If the device was already energized, wait 15 minutes so that the DC bus capacitors can discharge fully. ▪ Make sure that the unit is de-energized | Covers |
| | | <ul style="list-style-type: none"> ▪ Before putting the unit into operation, make sure that all electrical connections are undamaged and properly connected | Covers |
| Risk of electric shock posed by live parts | <ul style="list-style-type: none"> ▪ On the unit and on neighboring metal parts ▪ On the unit and on neighboring metal accessories | <ul style="list-style-type: none"> ▪ Before putting the unit into operation, make sure that it is bonded to an electrical ground system together with all metal accessories | Bonding system |

Safety hazard: moving units on bases with casters

| Risk / hazard | Where and in which situations will the risk/hazard exist? | What to do | Safety device |
|--|--|---|-------------------|
| All the risks and hazards listed below | When units are being moved on a base with casters | <ul style="list-style-type: none"> ▪ Before moving the unit (to clean the combi oven's case or the floor, for example), check to make sure that the retaining element designed to limit how much the base can move with the unit is attached. ▪ De-energize the unit before moving it ▪ When moving the unit, make sure not to roll over any connection lines (electrical and water) | Retaining element |
| Pinch point hazard (for multiple body parts) | When units are being moved on a base with casters | <ul style="list-style-type: none"> ▪ Pay attention to the utility and hose connections. ▪ Use at least two people to move the unit | None |
| Pinch point hazard (hand and foot hazard) | When units are being moved on a base with casters | Keep the unit doors shut | None |
| Risk of scalding posed by hot wastewater | When units are being moved on a base with casters | <ul style="list-style-type: none"> ▪ Let the units cool down ▪ Immediately wipe or mop up any water that has leaked ▪ Wear appropriate protective clothing | None |
| Risk of scalding posed by hot, liquid food | When units are being moved on a base with casters | Do not move units if there is any food still in them | None |
| Risk of electric shock posed by live parts | When units are being moved on a base with casters | Pay attention to the utility and hose connections. | None |
| Skin and eye irritation hazard as a result of contact with cleaning agents | When units are being moved on a base with casters | <ul style="list-style-type: none"> ▪ Make sure that the connections are long enough ▪ When moving the base, keep the cleaning agent canisters closed | None |
| Trip hazard as a result of utility and hose connections routed in the open | When cleaning behind units that have been pulled forward | Exercise caution when performing maintenance work | None |
| Fall hazard as a result of floors being wet with wastewater | <ul style="list-style-type: none"> ▪ When cleaning behind units that have been pulled forward ▪ In front of the unit | <ul style="list-style-type: none"> ▪ Immediately wipe or mop up any water that has leaked ▪ Make sure that the connections are long enough | None |
| Fall hazard as a result of floors being wet with cleaning agents | <ul style="list-style-type: none"> ▪ When cleaning behind units that have been pulled forward ▪ In front of the unit | When moving the units, keep the cleaning agent canisters closed | None |

Additional safety hazards when placing the unit into operation

When putting the unit into operation, make sure to read and understand the following topics in the 'For Your Safety' section of the user manual in addition to the safety information in this section.

- Hazards and Safety Measures During Operation
- Hazards and Safety Measures During Cleaning
- Personal protective equipment

3.8 Hazards and Safety Measures When Removing the Unit from Service

Safety hazard: electricity

When removing the unit from service, keep the following hazards in mind and take the actions required in order to eliminate and/or minimize these hazards:

| Risk / hazard | Where and in which situations will the risk/hazard exist? | What to do | Safety device |
|--|---|--|---------------|
| Risk of electric shock posed by live parts | <ul style="list-style-type: none"> ▪ Under covers ▪ Under the operating panel | <ul style="list-style-type: none"> ▪ Work on the unit's electrical components should be performed exclusively by a qualified electrician from an authorized customer service company ▪ Work professionally <p>Before removing the covers:</p> <ul style="list-style-type: none"> ▪ De-energize all connections ▪ Lock out and tag out all switches ▪ Wait 15 minutes so that the DC bus capacitors can discharge fully ▪ Make sure that the unit is de-energized | Covers |

Safety hazard: moving heavy loads

When removing the unit from service, keep the following hazards in mind and take the actions required in order to eliminate and/or minimize these hazards:

| Risk / hazard | Where and in which situations will the risk/hazard exist? | What to do | Safety device |
|--|---|--|---------------|
| Risk of injury due to excessive exertion | Whenever moving the unit | <ul style="list-style-type: none"> ▪ Use appropriate lifting equipment ▪ Do not lift or carry too much weight! ▪ Use carrying straps ▪ Wear the required personal protective equipment | None |

Safety hazard: moving units on bases with casters

| Risk / hazard | Where and in which situations will the risk/hazard exist? | What to do | Safety device |
|--|--|---|-------------------|
| All the risks and hazards listed below | When units are being moved on a base with casters | <ul style="list-style-type: none"> ▪ De-energize the unit before moving it ▪ Check to make sure that the retaining element that limits the moving radius for the base with the unit is attached before moving the base (in order to get access to the back of the unit, for example). ▪ When moving the unit, make sure not to roll over any connection lines (electrical and water) | Retaining element |
| Pinch point hazard (for multiple body parts) | When units are being moved on a base with casters | <ul style="list-style-type: none"> ▪ Pay attention to the utility and hose connections. ▪ Use at least two people to move the unit | None |
| Pinch point hazard (hand and foot hazard) | When units are being moved on a base with casters | Keep the unit doors shut | None |
| Risk of scalding posed by hot wastewater | When units are being moved on a base with casters | <ul style="list-style-type: none"> ▪ Let the units cool down ▪ Immediately wipe or mop up any water that has leaked ▪ Wear appropriate protective clothing | None |
| Risk of scalding posed by hot, liquid food | When units are being moved on a base with casters | Do not move units if there is any food still in them | None |
| Risk of electric shock posed by live parts | When units are being moved on a base with casters | Pay attention to the utility and hose connections. | None |
| Skin and eye irritation hazard as a result of contact with cleaning agents | When units are being moved on a base with casters | <ul style="list-style-type: none"> ▪ Make sure that the connections are long enough ▪ When moving the base, keep the cleaning agent canisters closed | None |
| Trip hazard as a result of utility and hose connections routed in the open | When cleaning behind units that have been pulled forward | Exercise caution when performing maintenance work | None |
| Fall hazard as a result of floors being wet with wastewater | <ul style="list-style-type: none"> ▪ When cleaning behind units that have been pulled forward ▪ In front of the unit | <ul style="list-style-type: none"> ▪ Immediately wipe or mop up any water that has leaked ▪ Make sure that the connections are long enough | None |
| Fall hazard as a result of floors being wet with cleaning agents | <ul style="list-style-type: none"> ▪ When cleaning behind units that have been pulled forward ▪ In front of the unit | When moving the units, keep the cleaning agent canisters closed | None |

Safety hazard: mechanical unit components

When removing the unit from service, keep the following hazards in mind and take the actions required in order to eliminate and/or minimize these hazards:

| Risk / hazard | Where and in which situations will the risk/hazard exist? | What to do | Safety device |
|---|--|--|--|
| Crush hazard posed by a loss of unit stability if the unit is set up in a stacking kit or on an equipment stand | <ul style="list-style-type: none"> ▪ When removing the unit from the equipment stand ▪ When removing units from a stacking kit ▪ If the top is subjected to a heavy uneven load | <ul style="list-style-type: none"> ▪ Do not, under any circumstance, subject the units to additional loads (on the open unit door, for example) ▪ Always remove the top unit from the stacking kit first ▪ Before removing units from a stacking kit with casters, lock the casters' wheels | Brake and swivel lock when using a stacking kit with casters |

Safety hazard: cleaning agents

| Risk / hazard | Where and in which situations will the risk/hazard exist? | What to do | Safety device |
|---|---|--|---------------|
| Skin, eye, and respiratory tract irritation hazard as a result of contact with cleaning agents and their vapors | <ul style="list-style-type: none"> ▪ When removing the cleaning system ▪ When disposing of the device | <ul style="list-style-type: none"> ▪ Wear the required personal protective equipment ▪ Observe the instructions and warnings on the cleaning agent labels and in the relevant safety data sheets | None |

3.9 Safety Devices

Meaning

The combi oven features a series of safety devices and guards that protect the user from a variety of hazards. All safety devices and guards must be present, fully functional, and locked properly without exception when the combi oven is being used.

3.10 Staff and Work Area Requirements

Staff requirements

The table below specifies the qualifications needed for each role. Provided that they have the required qualifications, a single person can take over more than one role if necessary.

| Role | Required qualifications | Tasks |
|---|--|---|
| Combi oven owner or the owner's employee who is responsible for the unit and for the staff operating it | Is familiar with the rules involved in handling heavy loads | <ul style="list-style-type: none"> ▪ Briefed on all of the combi oven's safety-relevant functions, mechanisms, and devices by the person placing the unit into operation so that the information can be relayed to all the staff operating the unit ▪ Shown how the unit is operated by the person placing the unit into operation so that the information can be relayed to all the staff operating the unit ▪ If necessary, helping out as directed with transportation within the facilities and with setting up the unit |
| Mover | <ul style="list-style-type: none"> ▪ Trained in the use of forklifts and/or pallet jacks ▪ Is familiar with the rules involved in handling heavy loads | Transporting the unit within the facilities |
| Service technician | <ul style="list-style-type: none"> ▪ Qualified staff from an authorized service company ▪ Has relevant technical training ▪ Has unit-specific training ▪ Is familiar with the rules involved in handling heavy loads ▪ Is able to assess whether the unit's power, water, and drain connections have been correctly set up. | <ul style="list-style-type: none"> ▪ Setting up the unit ▪ Installing the fully automatic oven cleaning system ▪ Placing the unit into operation ▪ Removing the unit from service |
| Electrician | <ul style="list-style-type: none"> ▪ Qualified staff from an authorized service company ▪ Has relevant training ▪ Is a qualified electrician | <ul style="list-style-type: none"> ▪ Connecting the unit to the electrical connection at the facilities ▪ Uninstalling electrical connections |
| Water and wastewater installer | <ul style="list-style-type: none"> ▪ Qualified staff from an authorized service company ▪ Has relevant training | <ul style="list-style-type: none"> ▪ Connecting the unit to the water connection at the facilities ▪ Uninstalling water connections ▪ Connecting the unit to the drain connection at the facilities ▪ Uninstalling the drain connection |
| Person placing the unit into operation (service technician) | <ul style="list-style-type: none"> ▪ Is an employee from an authorized service company who is responsible overall for placing the unit into operation ▪ Has relevant technical training ▪ Has unit-specific training ▪ Is familiar with the rules involved in handling heavy loads ▪ Is able to assess whether the unit's power, water, and drain connections have been correctly set up. | <ul style="list-style-type: none"> ▪ Briefing the owner or the responsible employee ▪ Checking all steps and conditions as per the checklists |

Work areas during installation and placement into operation

During installation and placement into operation, the work area for staff will be the entire area occupied by the unit and its surroundings.

3.11 Personal protective equipment

Transportation and setup

Wear the following personal protective equipment when transporting and setting up the combi oven:

| Task | Tools used | Personal Protective Equipment |
|--|--|--|
| <ul style="list-style-type: none"> ▪ Transporting the unit within the facilities ▪ Setting up the unit on a work table or stand or inside a stacking kit ▪ Setting up the unit at the installation location | <ul style="list-style-type: none"> ▪ Carrying straps ▪ Appropriate lifting equipment | <ul style="list-style-type: none"> ▪ Protective gloves ▪ Safety footwear ▪ A hard hat (e.g., when there are suspended loads, doing overhead work) |

Installation, placing the unit into operation, and removing it from service

| Task | Tools used | Personal Protective Equipment |
|--|---|---|
| Installing and uninstalling (removing from service) the following: <ul style="list-style-type: none"> ▪ Electrical connection ▪ Water connection ▪ Drain connection | Tools and equipment necessary for the specific task at hand | Work clothes and personal protective equipment based on the required task in accordance with country-specific regulations |
| Installing and uninstalling the fully automatic oven cleaning system | Tools and equipment necessary for the specific task at hand | The protective equipment required will depend on the cleaning agents being used, and may include: <ul style="list-style-type: none"> ▪ Respirator ▪ Safety eyewear ▪ Protective gloves ▪ Protective clothing/apron More detailed specifications regarding this equipment can be found in the EC safety data sheets for the cleaning agent(s) being used. For the latest version of these data sheets, please contact the manufacturer. Always follow the instructions and observe all warnings found on the labels used for the cleaning agent(s). |
| <ul style="list-style-type: none"> ▪ Placing the unit into operation ▪ Briefing the user | Tools and equipment necessary for the specific task at hand | Wear appropriate work clothes for kitchen work as required by your country-specific standards and regulations, especially: <ul style="list-style-type: none"> ▪ Protective clothing ▪ Heat-resistant gloves ▪ Safety footwear |
| Removing the unit (removing it from service) | <ul style="list-style-type: none"> ▪ Carrying straps ▪ Appropriate lifting equipment ▪ A forklift or pallet jack | <ul style="list-style-type: none"> ▪ Protective gloves ▪ Safety footwear ▪ A hard hat (e. g., when there are suspended loads, doing overhead work) |

4 Transportation

Purpose of this section

This section provides information on how to transport your unit.

This section is intended for the user, as well as for installers and authorized customer service companies.

4.1 Working Safely During Transportation

For Your Safety

Before starting your work, read and understand the hazards described in Hazards and Safety Measures During Transportation on page 21.

Personnel qualifications required for transporting the unit

Required qualifications for transporting the unit:

- The unit should be transported exclusively by personnel trained in the use of forklifts and/or pallet jacks.
- All staff must be familiar with the rules involved in handling heavy loads.

Personal protective equipment

Wear the personal protective equipment specified for your work in the 'Personal Protective Equipment' on page 35 section of 'For Your Safety'.

Moving heavy loads

WARNING

Risk of injury when lifting loads incorrectly

Lifting the unit incorrectly may result in injury (especially in the area of the torso) due to the unit's weight.

- ▷ Use a forklift, pallet jack, or appropriate lifting equipment to transport the unit.
- ▷ When lifting the unit, make sure to use an appropriate number of people as required by the unit's weight (guideline: 30 lbs to a maximum of 120 lbs depending on age, sex, and build). Comply with all occupational health and safety regulations that apply at the installation location!
- ▷ Wear the required personal protective equipment.

Unsuitable supporting surfaces

WARNING

Crush hazard posed by the unit falling down or toppling over

Body parts may be crushed if the unit falls down or topples over.

- ▷ Make sure never to place the unit on an unsuitable supporting surface.

4.2 Transporting the unit to the installation location

Required space during transportation

Make sure that the transportation route you will be following has enough space to accommodate the unit's entire width and height at all times.

The following table provides the minimum door width and height required in order to be able to get the combi oven to its intended installation location.

| | | Minimum door opening dimensions |
|--------|------|---------------------------------|
| Width | [in] | 22.8 |
| Height | [in] | 46.3 |

Load capacity for transportation

Make sure that the transportation equipment you will be using is able to handle the loads it will be transporting.

The required minimum load capacity for the transportation equipment is 183 lbs.

Transporting the unit to the installation location

Observe the following when transporting the unit:

- Always use a pallet to transport the unit.
- Always keep the unit upright when moving it.
- Transport the unit slowly and carefully and secure it in such a way that it cannot tip over. Make sure not to bump into the unit. Avoid uneven transportation routes and steep inclinations.

The following figure shows how the device should be transported when using a forklift:

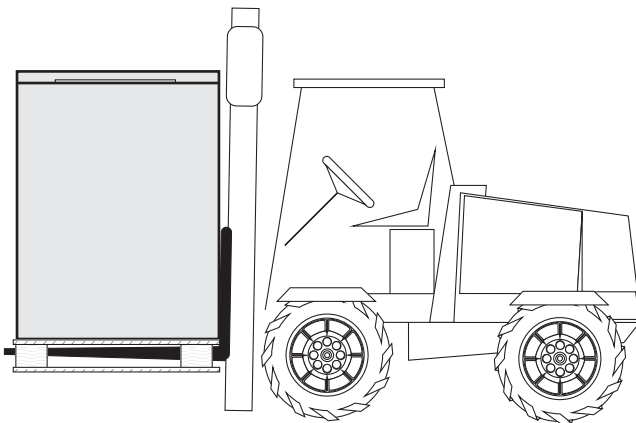

5 Setup

Purpose of this section

This section provides information on how to set up your unit.

This section is intended for the user, as well as for installers and authorized customer service companies.

5.1 Working Safely During Setup

For Your Safety

Before starting your work, read and understand the hazards described in Hazards and Safety Measures During Setup on page 22.

Personnel qualifications required for setting up the unit

Required qualifications for setting up the unit:

- The unit should be set up exclusively by qualified technicians from an authorized customer service company.

Setup standards and regulations

All national, state, and local standards and regulations concerning commercial kitchen operations must be complied with. These include, but are not limited to, the Food Code published by the Food and Drug Administration (FDA) (current edition) and the standards published by the National Sanitation Foundation (NSF).

The local rules and regulations that apply to the installation location, as defined by the relevant local authorities and utility companies, must be complied with.

Personal protective equipment

Wear the personal protective equipment specified for your work in the 'Personal Protective Equipment' on page 35 section of 'For Your Safety'.

Moving heavy loads

WARNING

Risk of injury when lifting loads incorrectly

Lifting the unit incorrectly may result in injury (especially in the area of the torso) due to the unit's weight.

- ▷ Use appropriate lifting equipment when placing the unit on a work table or equipment stand or in a stacking kit.
- ▷ When adjusting the unit's location, make sure to use an appropriate number of people to lift the unit as required by the latter's weight (guideline: 30 lbs to a maximum of 120 lbs depending on age, sex, and build). Comply with all occupational health and safety regulations that apply at the installation location!
- ▷ Use carrying straps when removing the unit from the pallet.
- ▷ Wear the required personal protective equipment.

Unsuitable supporting surfaces

 WARNING

Crush hazard posed by the unit falling down or toppling over

Body parts may be crushed if the unit falls down or topples over.

- ▷ Make sure never to place the unit on an unsuitable supporting surface.

5.2 Adjacent Systems

Handling exhaust air

During operation, the combi oven will produce heat and moisture, most of which will escape upwards into the ambient air in the form of hot steam coming through the air vent. Do not connect any lines or ducts directly to the combi oven's air vent!

The manufacturer recommends removing this exhaust air from the combi oven's working area with a range hood or ventilated ceiling.

In order to prevent fire hazards and other structural issues, such as corrosion, mold, and/or a decrease in stability, there must be sufficient clearance between the top of the unit and the ceiling. This clearance must be determined by taking the following into account:

- The reference point for the minimum vertical clearance (refer to 'Installation Location Requirements' on page 41).
- The type of exhaust system being used
- The characteristics of the ceiling at the installation location

The combi oven must always be set up, installed, and operated in compliance with all applicable country-specific and local standards and regulations.

5.3 Installation location requirements

Meaning

This section provides information on how to choose a suitable installation location for the unit. Carefully check the intended installation location to make sure it is adequate before bringing the unit there and starting with the installation!

Rules for safely setting up the unit

In order to prevent hazards that may be posed by the installation location and by the unit's surroundings, follow the rules below:

- It must be possible to adhere to the operating conditions at all times. For these operating conditions, please refer to 'Requirements concerning the combi oven's surroundings on page 18'.
- The heat loss at hot surfaces poses a fire hazard. Accordingly, set up the unit in non-combustible environments only.
- There must not be any flammable materials, gases, or liquids at a distance of less than 18" from the sides of the unit (right, left, front, back) and 40" from the top of the unit. When choosing an installation location, make sure to observe this requirement together with the requirements in the 'Adjacent Systems' on page 40 section and the unit's minimum space requirements without exception!
- Substructures (tables, frames) and supporting surfaces (floors, bases, countertops) must be made of non-combustible materials and must not be coated or covered with any flammable materials (no fiberboard, no contact between flammable materials and the bottom of the unit). Likewise, there must not be any flammable materials on the undersides of these structures. The unit supporting surfaces on substructures of this type must project beyond the unit's base on all sides by 12" or more.
- The minimum distance from heat sources in the vicinity of the units is 20".
- The minimum distance that must be maintained between the unit and any deep fryers or open kettle fryers in the vicinity is 40". The unit must be set up in such a way that liquids from the unit and from cooking processes will not be able to get to deep fryers and open kettle fryers under any circumstance.
- Do not set up the unit directly under a fire alarm or sprinkler system. The sensitivity of fire alarms and sprinkler systems must be adjusted in line with the amount of vapor and steam that the unit is expected to produce.
- The connection between the combi oven's drain pipe and the sewer system must be located outside the perimeter of the unit's base area. Due to potential wastewater vapors, there must not be a drain connection or open sewer line below the unit's base area.
- It must be possible to set up the unit's base (work table, equipment stand, or stacking kit) at the installation location in such a way that it will not topple over or shift. All supporting surface requirements must be met.
- The unit's base (equipment stand or stacking kit) must be secured in such a way that it cannot topple over if it is subjected to an uneven load (due to an open unit door, for example).
- In the case of units placed on a base with casters, a retaining element that limits how much the whole setup (base and unit) can move must be attached. It must not be possible to pull the base with the unit more than 20" forward.
The length of the corresponding utility and hose connections must take into account how much the retaining element will allow the base and unit to move. Do not roll over, pull, or otherwise subject the utility and hose connections to any tension when moving the whole setup (base and unit).
- The casters on the base must be lockable.
- With its current configuration, the unit is not designed to be used in environments where it could be subjected to strong vibrations or mechanical shock (e.g., on vehicles or ships).
- Vibrations must be avoided when using equipment stands or stacking kits.

Supporting surface requirements

The supporting surface must have the following characteristics:

- The supporting surface must be flat and level.
- The supporting surface must be capable of bearing the unit's weight during operation, plus the weight of the corresponding base.
- The base (work table or equipment stand) must be able to support a load equal to the unit's weight during operation.

The following table lists the various weights that make up the unit's weight during operation:

| Weight | |
|---|-------------------------------|
| Without base | |
| Unit weight when empty | [lbs] 155 |
| Maximum permissible loading weight | [lbs] 66 |
| Maximum weight of cleaning agents | [lbs] 44 |
| Unit weight during operation without base | [lbs] 265 |
| Base | |
| Equipment stand weight | [lbs] 23.5 |
| With base | |
| Unit weight during operation with equipment stand | [lbs] 290 |
| Unit weight during operation with work table | [lbs] 265 + work table weight |

Space required

In order to ensure that the combi oven will be used safely – especially when it comes to safely handling hot food –, it is necessary to keep a lot more free space than the minimum in front of the units! Generally speaking, it is recommended to maintain large clearances between the units and the walls in order to make it easier for service staff to access the unit as needed.

Do not cover, obstruct, or block the following parts at the installation location (please refer to 'The Combi Oven's Configuration and Functions on page 13' as well):

- The air vents at the top of the unit
- The dry air intake at the top of the unit
- Vents at the back of the unit
- Opening at the front between the feet

Minimum required space – width and depth

The following diagrams, as well as the following table, show the space required by the unit for various installation and operating situations, as well as the minimum horizontal clearances required relative to adjacent walls and surfaces.

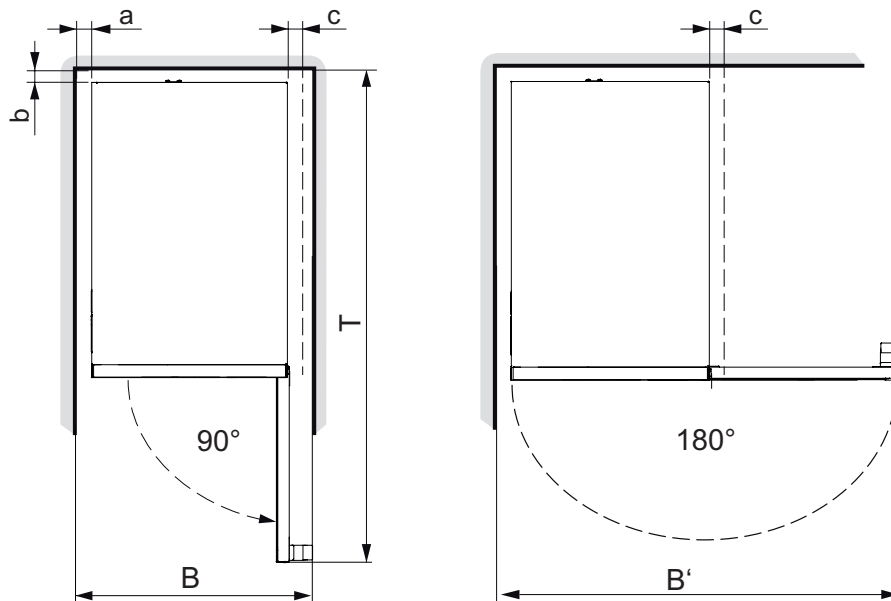

| Dimension | Meaning | Required space | |
|-----------|--|----------------|------|
| B | Minimum required space for the unit width when the door is opened 90° | [in] | 24.9 |
| B' | Minimum required space for the unit width when the door is opened 180° | [in] | 41.5 |
| D | Minimum required space for the unit depth (including open door) | [in] | 51.8 |
| a | Minimum wall clearance on the left side of the unit | [in] | 2.0 |
| b | Minimum wall clearance at the back of the unit | [in] | 2.0 |
| c | Minimum wall clearance on the right side of the unit | [in] | 2.0 |

Minimum space requirements – height

The following diagram and table show the vertical space required by the unit:

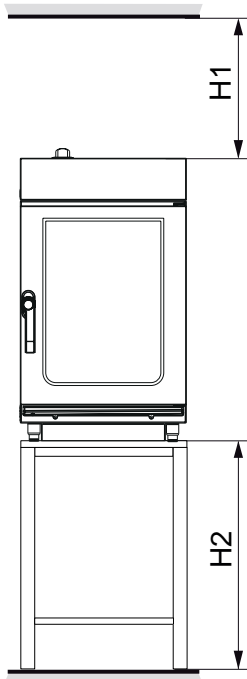

The service technician responsible for setting up the unit must take into account the ceiling's properties and any adjacent systems being used (air ventilation system, range hood) when determining the actual clearance required between the top of the unit and the ceiling. Vertical clearance H1 is only meant to serve as a reference point for the minimum vertical clearance.

| Dimension | Meaning | Required space | |
|-----------|--|----------------|-------------|
| H1 | Reference point for minimum vertical clearance | [in] | 20.0 |
| H2 | Installation height | [in] | 27.6 - 35.4 |

The topmost shelf must not be at a height exceeding 63".



This requirement will be met automatically if the unit is set up on one of the manufacturer's equipment stands. Please refer to Equipment stand dimensions and weights for more information.

5.4 Unpacking

Checking the tilt indicator

Before unpacking the unit, check the tilt indicator on the packaging.

The following table shows the various possible tilt indicator conditions:

| Indicator | Meaning | Procedure |
|--|---|---|
|  | Silver dot: The unit has been transported properly. | <ul style="list-style-type: none"> Unpack the unit Compare the tilt indicator's number with the number on the shipping documents. |
|  | Red dot: The device has been transported in a toppled or non-upright position. | <ul style="list-style-type: none"> Check the goods for damage. Compare the tilt indicator's number with the number on the shipping documents. Make a note of the tilt indicator dot color and of any damage on the shipping documents. |

Unpacking the unit

How to unpack the unit:

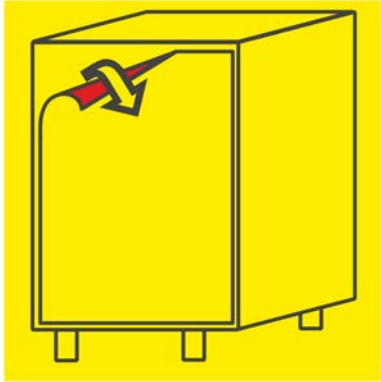
| Step | Procedure | Figure |
|------|--|--|
| 1 | Remove the outer packaging. | |
| 2 | Remove all cardboard boxes, packaging materials, customer documents, labels, and containers. Please make sure to dispose of all packaging materials in an environmentally responsible manner. | |
| 3 | Remove the protective film. |  |
| 4 | Check the combi oven for damage. If you suspect there is any transit damage, immediately notify your specialty retailer/carrier. In addition, notify the manufacturer in writing within three days. Do not, under any circumstance, install or operate damaged units. | |

Included equipment and parts

The following should be included with the unit:

- One combi oven
- One left-hand side rack
- One right-hand side rack
- One installation manual
- One operating manual
- One operating instructions document for easyStart

5.5 Removing the unit from the pallet

Removing the unit from the pallet using the carrying straps

To find out how much your unit weighs, consult the Technical Data on page 68 section.

Follow the steps below when lifting the unit off from the pallet:

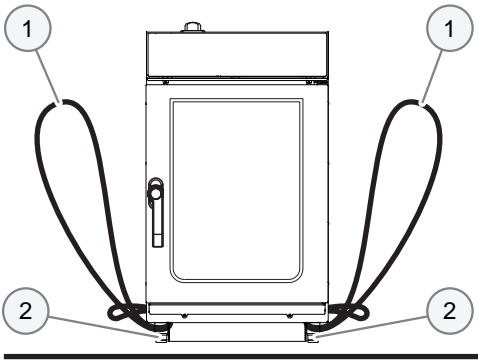
| Step | Procedure | Figure |
|------|---|--|
| 1 | Attach the carrying straps (1) to the feet (2). |  |
| 2 | Carefully lift the unit off from the pallet. | |

5.6 Setting up the unit on a work table

⚠ Rules for safely setting up the unit

Observe the following rules in order to ensure that the unit will have the required stability:

- It must be possible to set up the work table at the installation location in such a way that it will not topple over or shift. All supporting surface requirements must be met.
- The unit must be set up on the work table's surface in such a way that it will not topple over or shift.

Setting up the unit on a work table

Follow the steps below when setting up the unit on a work table:

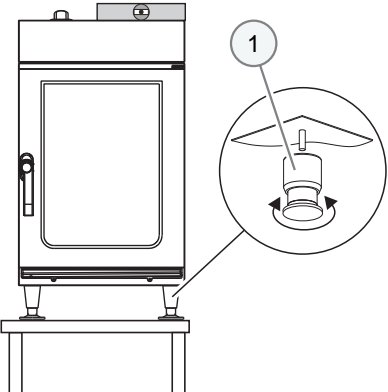
| Step | Procedure | Figure |
|------|--|--|
| 1 | Place the unit on the work table. |  |
| 2 | Use the unit's height-adjustable feet (1) to level the unit. Use a spirit level to make sure that the unit is properly leveled. | |

5.7 Setting Up the Unit on a Stand

⚠ Rules for safely setting up the unit

Observe the following rules in order to ensure that the unit will have the required stability:

- The unit's equipment stand must be secured in such a way that it cannot topple over if it is subjected to an uneven load (due to an open unit door, for example).
- It must be possible to set up the stand at the installation location in such a way that it will not topple over or shift. All supporting surface requirements must be met.

In order to comply with hygiene standards, the following rule must be observed:

- In the case of equipment stands with shelf levels for bakeware, the equipment stands' upper panel must be correctly in place in order to prevent food being temporarily stored in the equipment stand from being contaminated.

Setting Up the Unit on a Stand

Follow the steps below when setting up the unit on an equipment stand:

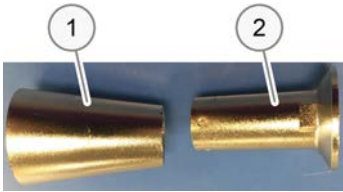
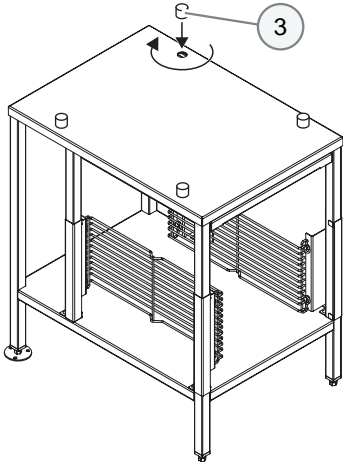
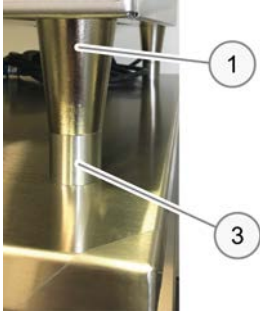
| Step | Procedure | Figure |
|------|--|---|
| 1 | Unscrew the four feet and remove them completely from the unit. | |
| 2 | Unscrew and remove the lower part (2) of the foot and then screw the upper part (1) of the foot back onto the unit. You will not be needing the lower part of the foot anymore. |  |
| 3 | Screw the four spacers (3) included with the stand onto the stand. |  |
| 4 | Set the unit on the stand and insert the feet (1) into the sleeve mounts (3) so that they will be securely in place. |  |

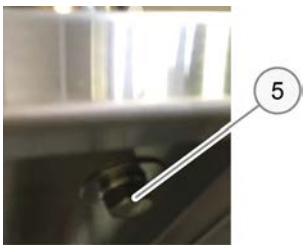
| Step | Procedure | Figure |
|------|--|---|
| 5 | Use the enclosed screws (5) to screw the unit onto the equipment stand from below. |  |
| 6 | Position the device with the stand and use the height-adjustable feet to level the stand. Use a spirit level to make sure that the unit is properly leveled. | |
| 7 | Fasten the base on the flange feet. | |

6 Installation

Purpose of this section

This section goes over how to connect your combi oven.

6.1 Electrical installation

Purpose of this section

This section goes over how to electrically install the unit.

6.1.1 Working Safely When Installing the Electrical Installation

For Your Safety

Before starting your work, read and understand the hazards described in Hazards and Safety Measures During Installation on page 24.

Personnel qualifications required for electrically installing the unit

Work on electrical equipment should be performed exclusively by electricians from an authorized service company who have the training and certifications required by all applicable country-specific and local regulations.

Personal protective equipment

Wear the personal protective equipment specified for your work in the 'Personal Protective Equipment' on page 35 section of 'For Your Safety'.

Electrical installation standards and regulations

In order to prevent hazards related to improperly installed electrical connections, make sure to observe the following standards and regulations:

- The connection to the power supply must be installed in accordance with the National Electrical Code, ANSI/NFPA 70 (current edition); the Canadian Electrical Code, CSA C22.2; all other applicable national and state laws and regulations; and the local requirements set forth by the relevant local utility companies, trade associations, and authorities.

Live parts

WARNING

Risk of electric shock posed by live parts and loose cables

Electric shock may occur when coming into contact with live parts after opening the cover.

- ▷ Make sure that all electrical work is performed exclusively by a qualified electrician from an authorized customer service office.
- ▷ Follow the steps below before removing the safety covers:
 - De-energize all connections.
 - Lock out and tag out all switches.
 - If the device was already energized, wait 15 minutes so that the DC bus capacitors can discharge fully.
 - Make sure that the unit is de-energized.
- ▷ Before putting the unit into operation, make sure that all electrical connections are undamaged and firmly connected.
- ▷ Before putting the unit into operation, make sure that it is bonded to an electrical ground system together with all metallic accessories.

6.1.2 Planning the Electrical Installation

Meaning

It is crucial for the unit's electrical system to be properly installed in order for the unit to run safely and without any problems. All the rules and specifications specified in this section, as well as the procedures described, must be followed to the letter.

Rules for safely installing the units electrically

In order to prevent hazards related to improperly installed electrical connections, make sure to observe the following rules:

- The unit's case must be properly grounded as per generally accepted standards and practices and connected to an electrical ground system.
- If there are two units mounted in a single stacking kit, both the units' cases and the stacking kit must be properly grounded as per generally accepted standards and practices and connected to an electrical ground system.
- The length of the field installed conductors and the length of the flexible conduit must take into account how much the retaining element on the base allows the unit to move. Do not roll over, pull, or otherwise subject the field installed conductors to any tension when moving the whole setup (base and unit). This also applies to any other additional electrical connection cables between the combi oven and optional accessories, such as a signal tower.
- While placing the unit into operation, check all electrical cables and connections to make sure they have been routed properly and installed correctly as per generally accepted standards and practices.

Equipment provided by the customer and electrical installation rules

The following table shows the equipment that must be provided by the customer and the rules that have to be followed when making the relevant electrical connections.

| Equipment | Rules |
|--------------------------|--|
| Fuse | The unit must be fused and connected in accordance with all applicable local regulations and country-specific installation regulations. |
| Electrical ground | The unit must be connected to an electrical ground system. If there are two units mounted in a single stacking kit, both the units' cases and the stacking kit must be properly connected to an electrical ground system. Electrical ground: An electrical connection that brings the frames of electrical equipment and other conductive parts to the same or approximately the same potential. |
| Disconnecter | An easily accessible all-pole power disconnection with a contact gap of at least 0.12" must be installed. The unit must be connected through this power disconnector. The power disconnection will then be used to de-energize the unit before performing cleaning, repair, and installation work. Installation must comply with all applicable local standards and regulations. In the case of permanent installations, a disconnecter is required. |

Power supply

The power cord must be an oil-resistant, jacketed, flexible cable that complies with the applicable local regulations. It is recommended for the field installed conductors not to exceed a length of 5½ ft. A warning label must be affixed to the power cord; please refer to 'Warning labels on the combi oven' on page 19.

The length of the power cord used for units placed on a base with casters must take into account how much the retaining element on the base allows the unit to move. Do not pull or otherwise subject the field installed conductors to any tension when moving the whole setup (base and unit).

A specific phase rotation direction or phase sequence is not required when connecting the unit.

6.1.3 Performing the Electrical Installation

Prerequisites

Check whether the following prerequisite is met:

- The unit's connection point has been de-energized and locked and tagged out.

Checking the rating data and electrical connections

Follow the steps below to check the connection to the electrical system and the electrical connections:

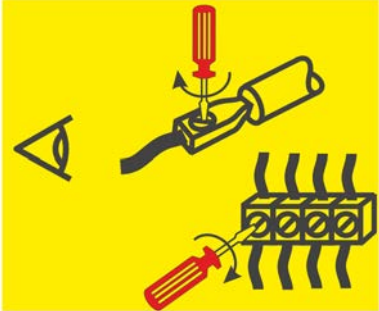
| Step | Procedure | Figure |
|------|---|--|
| 1 | Remove the unit's rear panel. The circuit diagram and the spare parts list will be located inside the wiring compartment. | |
| 2 | Check to make sure that the electrical rating data on the nameplate matches the specifications in the circuit diagram and the characteristics of the building's electrical system. Do not connect the combi oven unless all specifications match. | |
| 3 | Check all screw and crimp terminal connections on the unit. The connections may have become loose during transportation. |  |

Performing the Electrical Installation

Follow the steps below to electrically connect your unit:

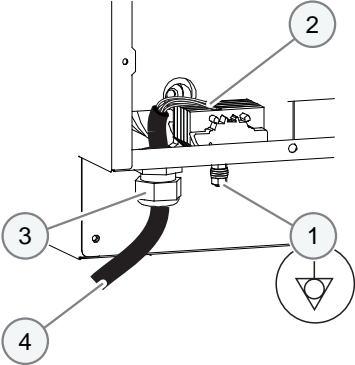
| Step | Procedure | Figure |
|------|--|---|
| 1 | Connect the unit to an electrical ground system at the intended connection point (1). |  |
| 2 | Check to make sure that the power cord is properly connected to terminal block -X10 (2). | |
| 3 | Make sure that the cable fitting (3) has a secure fit. This fitting serves as a strain relief. | |
| 4 | If necessary, reset the safety thermostat. | |
| 5 | Put the unit's rear panel back in place and check that it is mounted properly. | |
| 6 | Connect the appropriate power plug to the power cord (4). | |
| 7 | Carry out the relevant country-specific electrical tests. | |

6.2 Water connection

Purpose of this section

This section goes over how to set up the water connection.

6.2.1 Working Safely When Setting Up the Water Connection

For Your Safety

Before starting your work, read and understand the hazards described in Hazards and Safety Measures During Installation on page 24.

Personnel qualifications required for the water connection

The combi oven should be connected to the water supply and the wastewater system exclusively by trained technicians from an authorized service company who specialize in water and wastewater system installations.

Personal protective equipment

Wear the personal protective equipment specified for your work in the 'Personal Protective Equipment' on page 35 section of 'For Your Safety'.

Water connection standards and regulations

Make sure to comply with all national and state laws and regulations that apply to the water connection, as well as with all applicable local requirements and regulations set forth by the relevant local water utilities and authorities. These include, but are not limited to:

- Latest edition of the International Plumbing Code published by the International Code Council (ICC) or the Uniform Plumbing Code published by the International Association of Plumbing and Mechanical Officials (IAPMO)
- The Food Service Sanitation Manual published by the Food and Drug Administration (FDA)
- The standards published by the National Sanitation Foundation (NSF)

The unit may need to be installed with an appropriate backflow preventer in order to comply with all applicable federal, state, and local laws and regulations.

Drain connection standards and regulations

Make sure to comply with all national and state laws and regulations, as well as with all applicable local requirements and regulations set forth by the relevant local utilities and authorities, that apply to the drain connection and to the wastewater's properties. These include, but are not limited to:

- Latest edition of the International Plumbing Code published by the International Code Council (ICC) or the Uniform Plumbing Code published by the International Association of Plumbing and Mechanical Officials (IAPMO)
- The Food Service Sanitation Manual published by the Food and Drug Administration (FDA)
- The standards published by the National Sanitation Foundation (NSF)

6.2.2 Water supply

⚠ Rules for safely installing the water connection

In order to prevent hazards related to an improperly installed water connection, make sure to observe the following rules:

- In the case of units placed on a base with casters, the water connection must use a flexible hose.
- The length of the water connection line must take into account how much the retaining element on the base allows the unit to move. Do not roll over, pull, or otherwise subject the water connection hose to any tension when moving the whole setup (base and unit).
- The unit must be connected to a cold water pipe.

Water connection configuration

The combi oven is designed for a fixed water connection installed on-site. Mesh strainers must be used.

Connecting the water connection with a flexible connection hose

The unit can be connected to the water supply using a flexible GHT-M water connection hose that has a 3/4" fitting. Mesh strainers must be used.

Water quality and water hardness

Check the water quality as explained in 'Checking the Water Quality'.

Compare the water quality and water hardness of the water supplied through the building's supply connection with the specifications in the 'Technical Data' section (please refer to Water quality on page 70). If the required conditions are not met, you must install an adequate water filter and water treatment equipment. For more information on the required sizing, please refer to the Technical data and connection drawing on page 68 section.

Installation diagram with water treatment system

The following diagram shows the connection diagram for installations with a water treatment system:

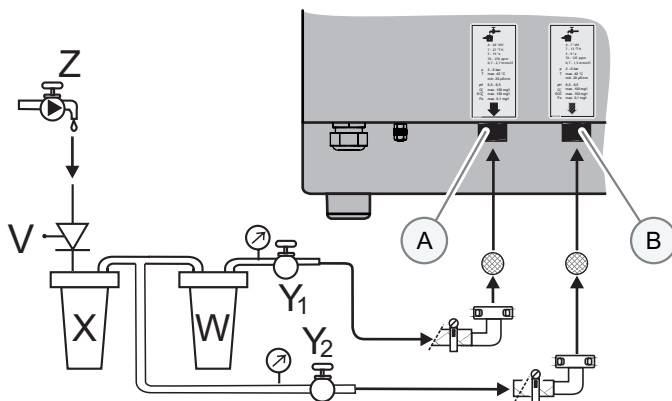

| No. | Designation | Explanation |
|-----|---------------------------------------|--|
| A | Soft water connection | For drinking water quality information, refer to the 'Technical Data' on page 68 section |
| B | Cold water connection | |
| Z | Water supply provided by the customer | Drinking water quality |
| X | 0.003" sediment filter | A 0.003" sediment filter needs to be installed if the water has a lot of impurities. |
| W | Water treatment system | If the required values are exceeded, a water treatment system must be installed. |

| | | |
|----------|------------------------------------|--|
| Y | Shut-off device with mesh strainer | Water valve |
| V | Appropriate backflow preventer | The unit must be installed with an appropriate backflow preventer in order to comply with all applicable federal, state, and local laws and regulations. |

Installing the water supply connection

Follow the steps below to set up the water supply for your combi oven:

| Step | Procedure |
|------|--|
| 1 | Ask your local water company for information regarding the quality and hardness of the water you get. If required, use suitable water treatment solutions. For information on the required properties for the fresh water used with the unit, please refer to the Technical Data on page 68 section. |
| 2 | Flush the water connection on the on-site water line (Z). |
| 3 | Install the sediment filter (X) and, if necessary, a water treatment system (W). |
| 4 | Install a separate shut-off device with a mesh strainer for each unit (Y or Y ₁ /Y ₂). |
| 5 | Install an appropriate backflow preventer (V) in the water supply line if required by local regulations. |
| 6 | Connect the unit as shown in the connection drawing. |
| 7 | Flush the sediment filter and, if applicable, the water treatment system. |
| 8 | Once you are done installing the water connection, close the shut-off device. |
| 9 | Inform the user of the maintenance intervals for the filters and for the water treatment system (if any). |

6.2.3 Water drain

⚠ Rules for safely installing the drain connection

In order to prevent hazards related to an improperly installed drain connection, make sure to observe the following rules:

- The drain pipes must be made of PVC or copper and must be able to withstand a temperature of 140 °F.
- The drain pipe must not taper or have any other diameter-reducing deformations at any point.
- The drain pipe's minimum diameter will depend on the pipe's total length and the number of elbows used. For a pipe length of up to 6 feet and a maximum of two elbows, the minimum inner diameter will be 1½". For a pipe length of 6 to 12 feet or a maximum of three elbows, the minimum inner diameter will be 2".
- The drain pipe must have a downward slope of at least 5% (3°).
- The unit drain must not be directly connected to the sewer system vertically.
- The connection between the drain pipe and the sewer system must be located outside the perimeter of the unit's base area. Due to potential wastewater vapors, there must not be a drain connection or open sewer line below the unit's base area.
- The drain connection must be implemented using a rigid, naturally ventilated pipe.
- A ventilation clearance of at least 1" must be maintained between the end of the drain pipe and the upper edge of the drain or pan.
- No other units may be connected to the combi oven's drain pipe.
- The combi oven must not be connected to any other units' drain pipe.

Connection diagram

The following diagram shows the connection diagram for a fixed wastewater connection installation:

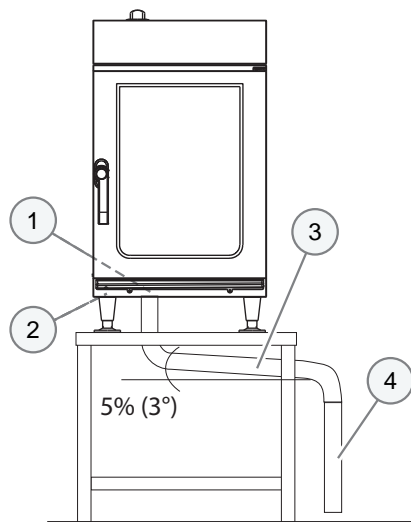

| No. | Meaning | Explanation |
|-----|---------------------|--|
| 1 | Drain connection | <ul style="list-style-type: none"> ▪ At the back of the combi oven. Connection drawing: point C |
| 2 | Safety overflow | <ul style="list-style-type: none"> ▪ At the bottom of the combi oven. Connection drawing: point M ▪ Used to drain water in the event of a failure (blockage) |
| 3 | 1½" drain pipe | <ul style="list-style-type: none"> ▪ Minimum inner diameter = 1½" ▪ Downward slope: min. 5% (3°) |
| 4 | 1½" (2") drain pipe | <ul style="list-style-type: none"> ▪ Minimum inner diameter = 1½" (2") ▪ Downward slope: min. 5% (3°) |

Installing the water drain

Follow the steps below to set up the water drain for your combi oven:

| Step | Procedure |
|------|--|
| 1 | Connect the unit as shown in the connection diagram. |

6.3 ConvoClean System Installation

Purpose of this section

This section goes over how to set up the fully automatic ConvoClean oven cleaning system.

6.3.1 Working Safely When Installing the ConvoClean System

For Your Safety

Before starting your work, read and understand the hazards described in Hazards and Safety Measures During Installation on page 24.

Personnel qualifications required for installing the ConvoClean system

The unit should be connected exclusively by qualified technicians from an authorized customer service company.

Personal protective equipment

Wear the personal protective equipment specified for your work in the 'Personal Protective Equipment' on page 35 section of 'For Your Safety'.

Contact with cleaning agents

WARNING

Risk of chemical burns and skin, eye, and respiratory tract irritation

The ConvoClean new cleaning agent and the ConvoCare rinse aid will cause skin, eye, and respiratory tract irritation upon direct contact. The ConvoClean forte cleaning agent will result in chemical burns to the skin, eyes, and respiratory tract upon direct contact.

- ▷ Do not inhale the cleaning agents' and rinse aid's vapors or mist.
- ▷ Do not let the cleaning agents or rinse aid come into contact with your eyes, skin, or mucous membranes.
- ▷ Observe all the instructions and warnings on the cleaning agent labels and in the corresponding safety data sheets when handling cleaning agents.
- ▷ Wear the required personal protective equipment.

6.3.2 Components of Fully Automatic Oven Cleaning System

Cleaning agents and rinse aid

Only use the products specified here in order to clean the combi oven.

NOTICE! The warranty will be void if there is any damage that can be traced back to the use of incorrect cleaning agents.

The following table lists the cleaning agents and rinse aids that can be used:

| Designation | Product | Label color |
|-----------------|------------------|-------------|
| Cleaning agents | ConvoClean forte | Red |
| Rinse aid | ConvoCare | Green |

Components of Fully Automatic Oven Cleaning System

The following diagram shows how the fully automatic oven cleaning system is laid out:

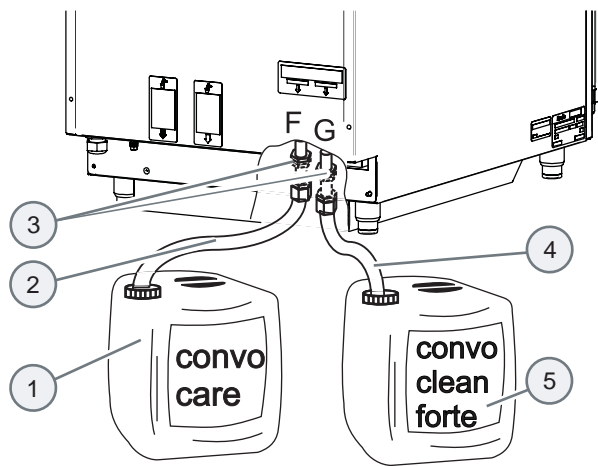

| No. | Designation | Color coding |
|-----|---|---------------------|
| 1 | ConvoCare rinse aid canister | Green (label) |
| 2 | Suction tube with suction nozzle for rinse aid | Green (tube) |
| 3 | D10 wire hose clamp | - |
| 4 | Suction tube with suction nozzle for cleaning agent | Red (tube) |
| 5 | ConvoClean forte cleaning agent canister | Red (label) |
| F | Unit connection for rinse aid | Green (inscription) |
| G | Unit connection for cleaning agent | Red (inscription) |

Installation location for cleaning agent and rinse aid canisters

Set up the canisters as follows:

- The canisters should be easily accessible on a flat, level surface next to the device.
- The canisters' location must be lower than the level at which the unit is resting on its base.
- The contact point between the canisters and their supporting surface must not be more than 40" below the bulkhead fittings.

6.3.3 Connecting the Fully Automatic Cleaning System

⚠ Rules for safely connecting the fully automatic oven cleaning system

Getting the ConvoClean and ConvoCare connections mixed up may pose a risk of injury or illness when food cooked afterwards is eaten.

In order to prevent this risk, make sure to observe the following rules:

- When connecting ConvoClean forte and ConvoCare, make absolutely sure that the hoses are connected to the right fitting and the right canister cap.

Prerequisites

Check whether the following prerequisites are met:

- Cold water connection as specified in the Water Supply on page 54 section
- Drain connection as specified in the Water Drain on page 56 section
- Technical prerequisites as specified in the Technical Data on page 68 section

Connecting the Fully Automatic Cleaning System

Follow the steps below to connect the ConvoClean system:

| Step | Procedure |
|------|--|
| 1 | Slip the red suction tube (4) for the cleaning agent onto the barbed nipple on the outer bulkhead fitting (G) and secure the tube using the wire hose clamp (3) (see 'Cleaning agent connection' label at the back of the unit). |
| 2 | Slip the green suction tube (2) for the rinse aid onto the barbed nipple on the inner bulkhead fitting (F) and secure the tube using the wire hose clamp (3) (see 'Rinse aid connection' label at the back of the unit). |
| 3 | Insert the suction nozzle on the red suction tube into the ConvoClean forte canister (5). The tube must be routed without any kinks and the canister's vent opening must be open and clear. |
| 4 | Insert the suction nozzle on the green suction tube into the ConvoCare canister (1). The tube must be routed without any kinks and the canister's vent opening must be open and clear. |
| 5 | Start a cleaning sequence with the 1st setting and check to make sure that cleaning agent is sprayed inside. |

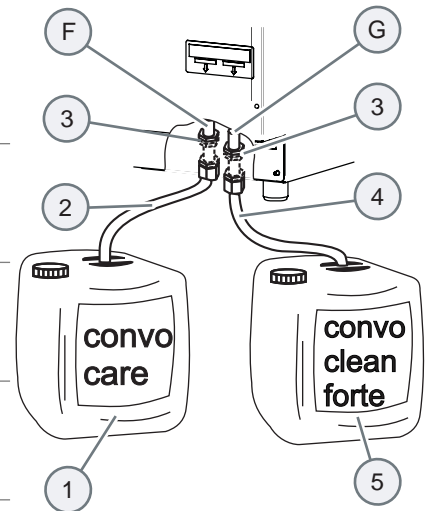

7 Placing into operation

Purpose of this section

This section goes over how to put your combi oven into operation, remove it from service, and dispose of it properly.

7.1 Working Safely When Putting the Unit Into Operation

For your safety when placing the combi oven into operation

Before starting your work, read and understand the hazards described in Hazards and Safety Measures When Placing the Combi Oven into Operation on page 26 and in the 'For Your Safety' section of the operating manual.

Personnel qualifications required for placing the unit into operation

Placing the unit into operation requires work to be performed under unusual operating conditions (e.g., with the safety covers removed) and includes tasks requiring qualifications and unit-specific skills that go beyond the requirements that must be met by the staff operating the unit.

The staff placing the unit into operation must meet the following requirements:

- They are employees working for an authorized customer service company.
- Must have relevant training as service technicians.
- Must have unit-specific training.
- The staff removing the unit from service must especially be able to assess whether the unit's power, water, and drain connections have been correctly installed.

Personal protective equipment

Wear the personal protective equipment specified for your work in the 'Personal Protective Equipment' on page 35 section of 'For Your Safety'.

Basic rules for safe operation

If the combi oven is moved in an impermissible manner after installation (on purpose or by accident), do not continue to operate the unit unless all the following requirements are met:

- The unit and the accessories being used do not have any obvious damage.
- The supply lines installed for electrical power, water, wastewater, and cleaning agents do not have any obvious damage, have a secure fit, are not dripping anywhere, and appear to be safe and fully functional after a visual inspection.
- The 'Requirements concerning the combi oven's functional capability on page 17' are being met.
- The 'Requirements concerning the combi oven's surroundings on page 18' are being met.
- All warning labels are at their intended location.

Rules for safely running the unit

In order to avoid hazards, follow the rules below when running the unit:

- Make sure to only use your hands when using the unit's controls (buttons, switches, touchscreens).
- Do not cover, obstruct, or block the air vent or the dry air intake at the top of the unit, the vents at the back of the unit, or the opening at the front between the feet.
- The racks need to be locked in place.
- Bakeware must be slid in properly; please refer to 'Placing Food Inside and Taking It Out' in the operating manual.
- The suction panel needs to be properly locked in place.

Additional rules for safely running the unit on a moving base

In order to avoid hazards, follow the rules below when running units on a base with casters:

- The retaining element used to limit how much the base can move with the unit must be attached at all times.
Every day before using the unit, check to make sure that the retaining element is attached.
- Make sure to always lock the front casters' wheels when the units are running
- Every day before using the units, check to make sure that casters' wheels are locked

Live parts

▲WARNING

Risk of electric shock posed by live parts and loose cables

Electric shock may occur when coming into contact with live parts after opening the cover.

- ▷ Make sure that all electrical work is performed exclusively by a qualified electrician from an authorized customer service office.
- ▷ Follow the steps below before removing the safety covers:
 - De-energize all connections.
 - Lock out and tag out all switches.
 - If the device was already energized, wait 15 minutes so that the DC bus capacitors can discharge fully.
 - Make sure that the unit is de-energized.
- ▷ Before putting the unit into operation, make sure that all electrical connections are undamaged and firmly connected.
- ▷ Before putting the unit into operation, make sure that it is bonded to an electrical ground system together with all metallic accessories.

Hot surfaces

▲WARNING

Risk of burns posed by high temperatures inside the oven cavity and on the inside of the unit door

Touching any interior oven cavity parts, the inside of the unit door, or any parts that are found inside the cooking compartment during cooking may result in burns.

- ▷ Wear the required personal protective equipment.

Contact with cleaning agents

▲WARNING

Risk of chemical burns and skin, eye, and respiratory tract irritation

The ConvoClean new cleaning agent and the ConvoCare rinse aid will cause skin, eye, and respiratory tract irritation upon direct contact. The ConvoClean forte cleaning agent will result in chemical burns to the skin, eyes, and respiratory tract upon direct contact.

- ▷ Do not inhale the cleaning agents' and rinse aid's vapors or mist.
- ▷ Do not let the cleaning agents or rinse aid come into contact with your eyes, skin, or mucous membranes.
- ▷ Do not spray cleaning agents or rinse aid into a oven cavity that is at a temperature higher than 140°F, as doing so will cause more caustic and/or irritating cleaning-fluid vapors to be produced.
- ▷ Wear the required personal protective equipment.

7.2 Procedure for Placing the Unit into Operation

Meaning

This section is intended to provide commissioning staff with an overview of the prerequisites that must be met before placing the combi oven into operation, as well as with information on how to place it into operation.

Checks before placing the unit into operation

Before putting the combi oven into operation, check whether the prerequisites below are being met:

- The unit does not have any obvious damage.
- The unit has been set up in such a way that it will not shift or topple over; the requirements concerning the location and the unit's surroundings are met (please refer to the Setup on page 38).
- Protective films, cardboard, securing devices for shipping, etc., have been removed completely.
- There is nothing being stored inside the oven cavity and there is nothing inside the oven cavity other than required cooking accessories (bakeware, for example).
- The unit has been installed as per the specifications in the Installation on page 50 section. Conduct this check using the Transportation, Setup, and Installation Checklist.
- The unit has been subjected to an individual electric inspection (see below).
- All safety guards and devices are in their intended place and are working properly. All warning labels are at their intended location. Conduct these checks using the Safety Guards, Safety Devices, and Warning Labels Checklist.

Do not place the unit into operation unless all specified prerequisites are met.

Individual electric inspection

An individual electric inspection includes the following three steps:

- Inspection: Visual inspection for damage and improper use
- Measurement: Measurements performed as per generally accepted standards and practices (equipment grounding conductor resistance, insulation resistance, equipment grounding conductor current / leakage current)
- Testing: Functional test

The individual electric inspection must be repeated at regular intervals as required by law.

Placing into operation

Follow the steps below to put the combi oven into operation:

| Step | Procedure | For more information... |
|------|--|--------------------------------------|
| 1 | Bring the ambient temperature to the permissible operating temperature. | |
| 2 | Turn on the circuit breaker. | |
| 3 | Open the water supply. | |
| 4 | Check to make sure that the following are installed properly in the right position: <ul style="list-style-type: none"> ▪ Suction panel ▪ Racks | Please refer to the operating manual |
| 5 | Turn the combi oven on. | Please refer to the operating manual |
| 6 | Configure the following settings: <ul style="list-style-type: none"> ▪ Date ▪ Time ▪ Language | Please refer to the operating manual |
| 7 | Select the 'Hot steam' cooking program: <ul style="list-style-type: none"> ▪ Set a temperature of 302°F and a duration of 10 minutes. | Please refer to the operating manual |

| Step | Procedure | For more information... |
|------|--|--------------------------------------|
| 8 | Check the following: <ul style="list-style-type: none">▪ Is the oven light on?▪ Is the fan running?▪ Are there any leaks in the wastewater and supply water systems?▪ Is the temperature increasing inside the oven cavity? | |
| 9 | Select the 'Steam' cooking program: <ul style="list-style-type: none">▪ Set a temperature of 212°F and a duration of 10 minutes. | Please refer to the operating manual |
| 10 | Check whether steam is being produced inside the oven (carefully open the door). | |
| 11 | Check the ConvoClean fully automatic cleaning system: <ul style="list-style-type: none">▪ Start the fully automatic cleaning sequence.▪ Check that ConvoClean forte and ConvoCare are being properly supplied. | Please refer to the operating manual |

Briefing the user

Brief the user on all safety-relevant functions, mechanisms, and devices. Show the user how to operate the unit.

8 Removing from Service and Disposal

Purpose of this section

This section goes over how to remove your combi oven from service and dispose of it properly.

8.1 Working Safely When Removing the Unit from Service

For your safety when removing the combi oven from service

Before starting your work, read and understand the hazards described in Hazards and Safety Measures When Removing the Combi Oven from Service on page 29.

Personnel qualifications required for removing the unit from service

Removing the unit from service requires work to be performed under unusual operating conditions (e.g., with the safety covers removed) and includes tasks requiring qualifications and unit-specific skills that go beyond the requirements that must be met by the staff operating the unit.

The staff placing the unit into operation must meet the following requirements:

- They are employees working for an authorized customer service company.
- Must have relevant training as service technicians.
- Must have unit-specific training.
- The staff placing the unit into operation must especially be able to assess whether the unit's power and water connections have been correctly installed.

Personal protective equipment

Wear the personal protective equipment specified for your work in the 'Personal Protective Equipment' on page 35 section of 'For Your Safety'.

Live parts

WARNING

Risk of electric shock posed by live parts and loose cables

Electric shock may occur when coming into contact with live parts after opening the cover.

- ▷ Make sure that all electrical work is performed exclusively by a qualified electrician from an authorized customer service office.
- ▷ Follow the steps below before removing the safety covers:
 - De-energize all connections.
 - Lock out and tag out all switches.
 - Wait 15 minutes so that the DC bus capacitors can discharge fully.
 - Make sure that the unit is de-energized.

Moving heavy loads

WARNING

Risk of injury when lifting loads incorrectly

Lifting the unit incorrectly may result in injury (especially in the area of the torso) due to the unit's weight.

- ▷ Use a forklift, pallet jack, or appropriate lifting equipment to transport the unit.
- ▷ When lifting the unit, make sure to use an appropriate number of people as required by the unit's weight (guideline: 30 lbs to a maximum of 120 lbs depending on age, sex, and build). Comply with all occupational health and safety regulations that apply at the installation location!
- ▷ Wear the required personal protective equipment.

Unsuitable supporting surfaces

▲WARNING

Crush hazard posed by the unit falling down or toppling over

Body parts may be crushed if the unit falls down or topples over.

- ▷ Make sure never to place the unit on an unsuitable supporting surface.

Contact with cleaning agents

▲WARNING

Risk of chemical burns and skin, eye, and respiratory tract irritation

The ConvoClean new cleaning agent and the ConvoCare rinse aid will cause skin, eye, and respiratory tract irritation upon direct contact. The ConvoClean forte cleaning agent will result in chemical burns to the skin, eyes, and respiratory tract upon direct contact.

- ▷ Do not inhale the cleaning agents' and rinse aid's vapors or mist.
- ▷ Do not let the cleaning agents or rinse aid come into contact with your eyes, skin, or mucous membranes.
- ▷ Observe all the instructions and warnings on the cleaning agent labels and in the corresponding safety data sheets when handling cleaning agents.
- ▷ Wear the required personal protective equipment.

8.2 Removing from Service and Disposal

Prerequisites

Check the following before removing the unit from service:

- The unit has been de-energized.
- The water supply has been shut off.

Removing from service

To remove your combi oven from service, undo all setup and installation work step-by-step in opposite order (please refer to the 'Installation on page 50', 'Transportation on page 36', and 'Setup on page 38' sections).

The following work must be done properly in order to remove the unit from service:

- Removing the unit's water connection
- Removing the unit's drain connection
- Removing or disconnecting the electrical connections
- Removing the door lock
- Properly disposing of all cleaning agents as indicated in the corresponding safety data sheets and the labels on the cleaning agent containers

9 Technical Data and Connection Drawing

9.1 Technical data

Dimensions and weights

The following table lists the various dimensions and weights:

| Dimensions and weights | | |
|--|-------|------|
| Width | | |
| With packaging | [in] | 22.8 |
| Without packaging | [in] | 20.3 |
| Depth | | |
| With packaging | [in] | 35.8 |
| Without packaging | [in] | 30.6 |
| Height | | |
| With packaging | [in] | 46.3 |
| Without packaging | [in] | 36.3 |
| Weight | | |
| With packaging | [lbs] | 183 |
| Without packaging | [lbs] | 155 |
| Safety clearances | | |
| Rear | [in] | 2.0 |
| Right-hand side | [in] | 2.0 |
| Left-hand side | [in] | 2.0 |
| Above (larger gap recommended for servicing) | [in] | 20.0 |

Equipment stand dimensions and weights

The following table shows the dimensions of the equipment stands for the combi oven, as well as the total height with the stand:

| | | Open equipment stand |
|-----------------------------------|-------|----------------------|
| Width | [in] | 20.3 |
| Depth | [in] | 25.7 |
| Height | [in] | 27.6 |
| Weight | [lbs] | 23.5 |
| Total height with equipment stand | [in] | 63.9 |

Maximum permissible loading weight

The following table lists the maximum permissible loading weight for each combi oven. These values apply under the condition that the weight loaded onto each shelf does not exceed 11 lbs:

| Maximum permissible loading weight | | |
|---|-------|----|
| Standard size bakeware (containers, oven racks, sheet pans) | | |
| Per combi oven | [lbs] | 66 |
| Per shelf | [lbs] | 11 |

Electrical ratings

The following table lists the various electrical rating specifications:

| Electrical ratings | | |
|--|------|-------------------|
| 3~ 208V-240V 60Hz (3/PE) | | |
| Rated power consumption | [kW] | 8.50 |
| Hot air output (RHK rated output) | [kW] | 8.16 |
| Motor output | [kW] | 0.25 |
| Rated current | [A] | 23.6 |
| Supplied with a 4 conductor 6 foot long cord | AWG | 8 |
| Conductor insulation rating | | SOOW |
| Plug (customer supplied) | NEMA | 15-50P or L15-50P |
| 3~ 208V-240V 60Hz (3/PE) | | |
| Rated power consumption | [kW] | 11.25 |
| Hot air output (RHK rated output) | [kW] | 11.12 |
| Motor output | [kW] | 0.25 |
| Rated current | [A] | 27.1 |
| Supplied with a 4 conductor 6 foot long cord | AWG | 8 |
| Conductor insulation rating | | SOOW |
| Plug (customer supplied) | NEMA | 15-50P or L15-50P |

Heat loss

The following table lists the various heat loss specifications:

| Heat loss | | |
|------------------|---------|------|
| Latent | [BTU/h] | 1740 |
| Sensible | [BTU/h] | 1911 |

Water connection

The following table lists the specifications for the water connection:

| Water connection | | |
|--------------------------|-------|---|
| Water supply (cold only) | | |
| Shut-off device | | The unit may need to be installed with an appropriate backflow preventer in order to comply with all applicable federal, state, and local laws and regulations. |
| Water supply | | |
| Connection | | Two 3/4" inner diameter GHT-M (garden hose adapter). The unit is designed for a permanent hookup to the water supply that uses a connecting hose with a minimum diameter of 1/2" |
| Flow pressure | [psi] | 43.5 - 87 psi (3 - 6 bar) |
| Water drain | | |
| Version | | Naturally ventilated pipe to open pan or drain/channel, min. 1" ventilation clearance |
| Type | [in] | Depending on the length of the line and the elements used in the line, the minimum inner diameter of the line is 1.5". |

Water quality

The following table lists water quality specifications:

| Water hardness for water injection | | |
|---|-------|---|
| Water quality | | Drinking water Soft water |
| Hardness | [ppm] | 70 - 125 (4 - 7 gpg) |
| TDS (total dissolved solids) | [ppm] | 70 - 125 |
| Total alkalinity | [ppm] | 50 - 100 |
| Water hardness for cleaning | | |
| Water quality | | Drinking water Hard water (or soft water; see above for specification) |
| Hardness | [ppm] | 70 - 360 (4 - 21 gpg) |
| TDS (total dissolved solids) | [ppm] | 70 - 360 |
| Total alkalinity | [ppm] | 50 - 100 |
| Figures | | |
| Temperature | [°F] | max. 104 |
| pH value | | 6.5 - 8.5 |
| Cl ⁻ (chloride) | [ppm] | max. 60 |
| Cl ₂ (free chlorine) | [ppm] | max. 0.2 |
| SO ₄ ²⁻ (sulfate) | [ppm] | max. 150 |
| Fe (iron) | [ppm] | max. 0.1 |
| SiO ₂ (silicate) | [ppm] | max. 13 |

Water consumption

The following table lists the combi oven's water consumption values:

| Water consumption | | |
|---|-------|---------|
| Cold water | | |
| Average water consumption | [gph] | 0 - 5.3 |
| Peak consumption | [gpm] | 2.6 |
| Soft water | | |
| Average water consumption for sizing the water filter | [gph] | 0 - 4.0 |

Unit specifications

The following table lists the various unit specifications:

| Unit specifications | | |
|---|-------|---------|
| Protection rating | | IPX4 |
| Conformity/certification marks in accordance with the applicable country-specific regulations | | UL, NSF |
| Noise emissions | | |
| Measured | [dBA] | max. 60 |

9.2 Connection drawing

OES 10.10 mini dimensions and connection points

The following table shows the various dimensions and connection points:

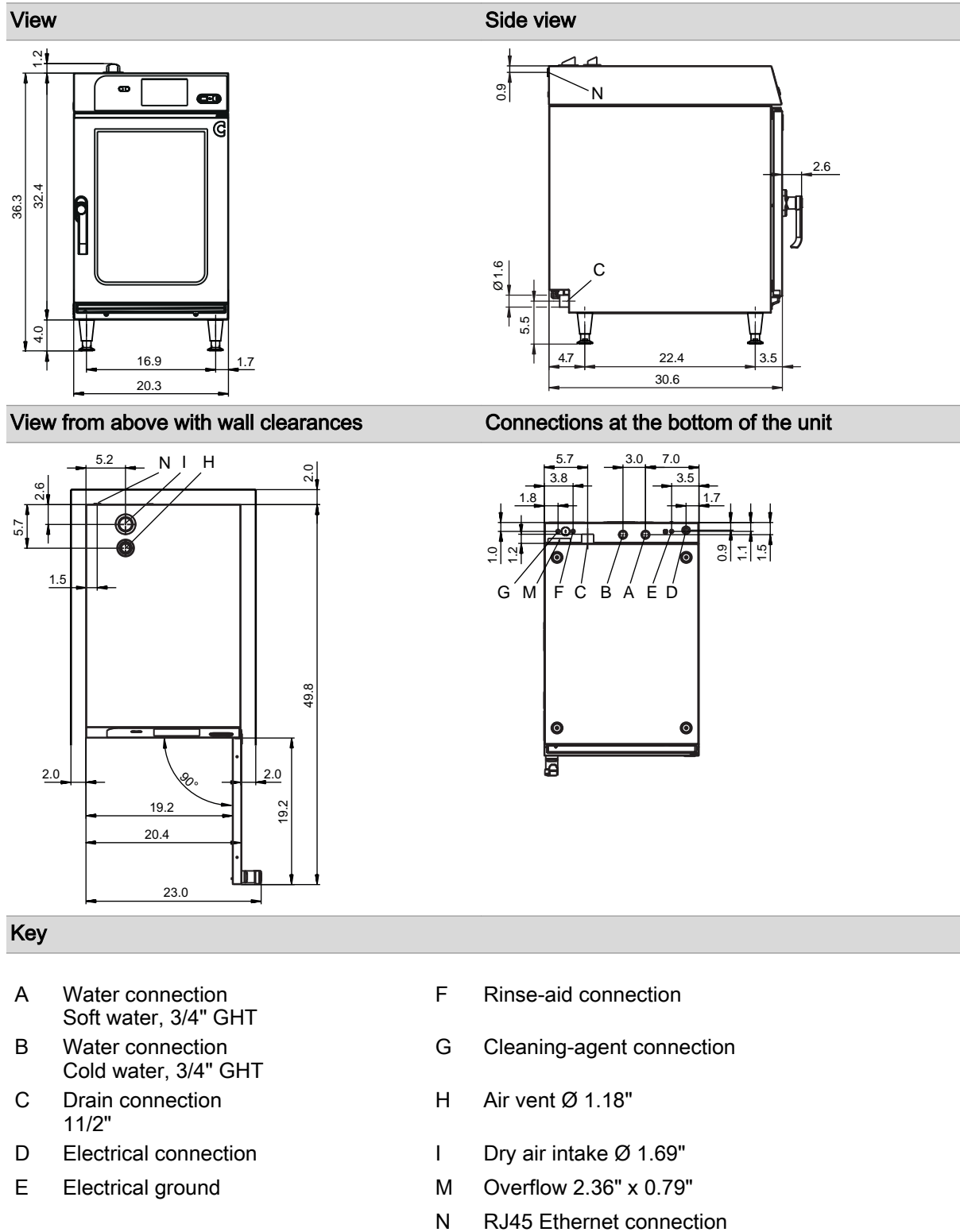

Combi Oven OES 10.10 mini easyTouch

Serial No.

Item no.

Order No.

Additional technical documentation can be found in the download center at :
www.convotherm.com



Welbilt offers fully-integrated kitchen systems and our products are backed by KitchenCare® aftermarket parts and service. Welbilt's portfolio of award-winning brands includes **Cleveland™**, **Convotherm®**, **Delfield®**, **fitkitchenSM**, **Frymaster®**, **Garland®**, **Kolpak®**, **Lincoln™**, **Manitowoc®**, **Merco®**, **Merrychef®** and **Multiplex®**.

Bringing innovation to the table • welbilt.com