

## Microwave combination oven

Part number: 32Z3923

 **Read instructions before use**

Models: 50Hz & 60Hz

Language: English

Date: Feb 2021/v1

*Expanding your Opportunities*

Section no.		Page no.
<b>1</b>	<b>General information</b>	<b>4</b>
1.1	Declaration of conformity	4
1.2	Environmental protection	4
1.3	Important information	4
1.4	Identifying your microwave combination oven	5
1.5	About this service and repair manual	6
<b>2</b>	<b>For your safety</b>	<b>7</b>
2.1	Basic safety code	7
2.2	Requirements to be met by personnel and working positions	8
2.3	Personal protective equipment	8
2.4	Intended use of the microwave combination oven	10
2.5	Warning signs on the microwave combination oven	11
2.6	Safety devices	12
2.7	Summary of hazards	13
2.8	Hazards and safety precautions when setting up the appliance, during installation, preparing the appliance for use and cleaning	13
2.9	Safe working when working on the appliance	14
2.10	Hazards and safety precautions during servicing and repair	14
2.11	Hazards and safety precautions when taking the appliance out of service	17
2.12	Safe working during electrical installation	18
2.13	Electrical installation requirements	19
2.14	Safe working when testing components	21
2.15	Process for discharging the capacitors	23
2.16	Safe working when replacing appliance parts	24
<b>3</b>	<b>Technical data</b>	<b>26</b>
3.1	Technical data charts	26
3.2	Dimensional drawings	32
<b>4</b>	<b>Accessing the easyTouch® screen</b>	<b>33</b>
4.1	Main menu screen	33
4.2	The keyboard screen	34
4.3	Cleaning procedures	35
4.4	Using a USB stick	36
4.5	Firmware updates	37
<b>5</b>	<b>Service information</b>	<b>42</b>
5.1	Service procedure	42
5.2	Errors and diagnostics	45
5.3	Fault finding	48
5.4	Safe working when testing components	55
5.5	Requirements	55
5.6	Testing selected components (casing mounted)	55
5.7	Recommissioning test	60
5.8	High voltage components (casing removed)	61
5.9	Mains voltage components (casing removed)	64
5.10	Optional components (casing removed)	66
<b>6</b>	<b>Replacing components</b>	<b>67</b>
6.1	Safe working when replacing appliance parts	67
6.2	Overview	67

---

6.3	Removing / fitting the casing	70
6.4	Removing / fitting the door assembly	71
6.5	Replacing the door gasket	73
6.6	Replacing a magnetron	74
6.7	Replacing the cooling fan	76
6.8	Replacing the QTS (Quick Touch Screen) assembly	77
6.9	Replacing the SRB (Smart Relay Board)	78
6.10	PM (Personality Module) replacement	79
6.11	Replacing the touchscreen control D and overlay	80
6.12	Adjusting the door microswitches/interlocks	81
6.13	Replacing the stirrer motor and stirrer assembly	83
6.14	Replacing the convection fan motor	85
6.15	Replacing a transformer (high voltage)	86
6.16	Removing the convection fan motor speed controller	87
6.17	Replacing the heating element	88
6.18	Overview – further components	89
6.19	Technical data summary sheet	94
<b>7</b>	<b>Circuit boards and diagrams</b>	<b>96</b>
7.1	SRB / QTS circuit boards	96
7.2	Circuit diagrams	99
<b>8</b>	<b>Annual PM check procedure for eikon® e2s</b>	<b>108</b>

## 1.1 Declaration of conformity

### Manufacturer

**Authorised representative (brand headquarters)**

Welbilt UK Limited  
Ashbourne House, The Guildway,  
Old Portsmouth Road  
Guildford GU3 1LR  
United Kingdom

**Factory**

Welbilt UK Limited  
Provincial Park,  
Nether Lane,  
Sheffield, S35 9ZX  
United Kingdom

### Equipment details

**Generic model number** eikon® e2s**Description** Commercial combination microwave oven

### Declaration of conformity with directives and standards

The manufacturer hereby declares that this commercial combination microwave oven complies with the required directives and standards. Please see the Installation and User Manual for further details.

### Quality and environmental management

Welbilt UK Limited (Sheffield) employs a quality management system and a certified environmental management system. Please see the Installation and User Manual for further details.

## 1.2 Environmental protection

### Statement of principles

Our customers' expectations, the legal regulations and standards and our company's own reputation set the quality and service for all our products.

We have an environmental management policy that not only ensures compliance with all environmental regulations and laws, but also commits us to continuous improvement of our green credentials.

We have developed a quality and environmental management system in order to guarantee the continued manufacture of high-quality products and to be sure of meeting our environmental targets.

### Environmental protection procedures

We observe the following procedures:

- Use of RoHS2-compliant products
- REACH chemical law
- Recycling of electronic waste
- Environmentally friendly disposal of old appliances via the manufacturer

**Join us in our commitment to protect the environment.**

## 1.3 Important information

Users are cautioned that maintenance and repairs should be performed by a Merrychef® authorised service agent using genuine Merrychef® replacement parts. Merrychef® will have no obligation with respect to any product that has been improperly installed, adjusted, operated or not maintained in accordance with national and local codes or installation instructions provided with the product, or any product that has its serial number defaced, obliterated or removed, or which has been modified or repaired using unauthorised parts or by unauthorised service agents. For a list of authorised service agents please refer to your distributor.

## 1.4 Identifying your microwave combination oven

### Position of nameplate

The nameplate is located on the rear of your microwave combination oven.

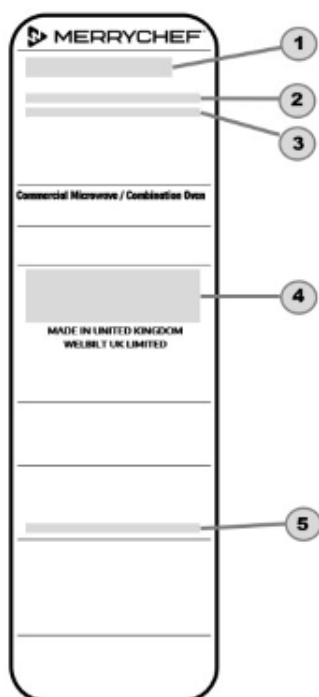

**1 Model number** eikon® e2s

**2 Item Number**

#### Elements of the item

Elements of the item	Label	Meaning
Model	e2s	
Power output convection	D	2200W
	F	2200W / 1300W
	G	2200W / 900W
Power output microwave	B	2000W (High power version)
	X	1000W (Standard power version)
Voltage	30	230V
	MV5	220-230V / 50Hz
	MV6	208-240V / 60Hz
	00	200V
Frequency	20	220V
	5	50Hz
	6	60Hz
Lead	A - Z	Examples: A= L+N+E (1.5mm) B = L1+L2+L3+N+E (2.5mm) G = L1+L2+L3+N+E (4mm) H = L+N+E (4mm)
Plug	A - Z	Examples: A = UK 13A 3-pin C = 32A 3ph D = 16A 3ph (90°) E = 32A 1ph
Communication	L	USB + LAN
	U	USB
Version	A, B	A, B (pre-production)
	1, 2, ...	1, 2, ... (serial production)
Accessory / Customer	CF	"Trend" exterior
	CL	"Classic" exterior
	WW	Specific customer
Region / Country	EU	Europe
	US	United States of America

**3 Serial Number**

#### Elements of the serial number

Elements of the serial number	Label	Meaning
Year of manufacture	15	2015
	16, ...	2016, ...
Month of manufacture	01	January
	02, ...	February, ...
Place of manufacture	2130	Sheffield (UK)
Production number	12345	

**4 Technical data**

**5 Manufacturer addresses**

## 1.5 About this Service and Repair manual

### Purpose

This service and repair manual is intended for all trained Merrychef service technicians who work with the microwave combination oven and provides them with the necessary information for carrying out servicing and repair work properly and safely.

### Who should read the Service and Repair manual?

**Name of target group:** Merrychef trained service technicians

**Tasks:** All servicing and repair work

### Parts of this document that must be read without fail

**If you do not follow the information in this document, you risk potentially fatal injury and property damage.**

To guarantee safety, all people who work with the microwave combination oven must have read and understood the following parts of this document before starting any work:

- Section 2 'For your safety'
- The sections that describe the activity to be carried out

### Safety alert symbol

#### Symbol



#### Meaning



Warns of potential injuries. Heed all the warning notices that appear after this symbol to avoid potential injuries or death.

### Form of warning notices

The warning notices are categorized according to the following hazard levels:

Hazard level	Consequences	Likelihood
 <b>DANGER</b>	Death / serious injury (irreversible)	Immediate risk
 <b>WARNING</b>	Death / serious injury (irreversible)	Potential risk
 <b>CAUTION</b>	Minor injury (reversible)	Potential risk
<b>NOTICE</b>	Damage to property	Potential risk

### Standards

This Service and Repair Manual has been written and produced in the UK, following UK and EU standards. Any additional local country standards, outside of the UK, must be understood and adhered to.



## 2 For your safety

### Purpose

This chapter provides you with all the information you need in order to work with the microwave combination oven safely without putting yourself or others at risk.

**This is a particularly important chapter that you must read through carefully.**

#### IMPORTANT:

This manual provides technical guidance for technicians who have successfully undertaken a recognized product familiarization and training course run by Merrychef to carry out service/repair tasks to the appliance/s shown on the front cover of this manual which must not be used for any other make or model of appliance.

Please remember that it is wiser not to attempt a service task if you are unsure of being able to complete it competently, quickly, and above all safely.

To avoid injury to yourself or others and to protect the appliance from possible damage, ensure you have read and understand all the relevant instructions and ALWAYS follow the safety codes when servicing an oven.

1. Ensure the electrical supply is locked-off to prevent the oven from being inadvertently powered up.
2. Do not leave the oven unattended without the oven panels fitted and keep within sight of other personnel when testing the oven, ensuring persons other than trained engineers are denied access.
3. The minimum number of panels should be removed, and the high voltage capacitors must be discharged before working on the oven using a suitable Capacitor Discharge tool (see section 2.15).
4. Temporary insulation should be used to prevent accidental contact with dangerous conductors.
5. Do not touch any internal wiring or connectors within the oven, whether you believe it is live or not and avoid touching the metalwork (casing, panels, etc) of the oven with your body.
6. Only use electrically rated screwdrivers for adjusting 'Pots' etc., ensuring the tool touches nothing else.
7. Ensure the test equipment is set correctly before use.
8. Test equipment such as meter test leads or clamps must be fitted and removed whilst the unit is dead, for each and every test.
9. Do not undertake functional magnetron testing with the panels of the casing removed.
10. Avoid touching the test equipment, unless necessary for the operation.
11. Upon completion of a service follow the steps for commissioning the oven under the "Commissioning the appliance" section of this manual.

## 2.1 Basic safety code

### Object of the safety code

This safety code aims to ensure that all persons who operate, install, service and repair the microwave combination oven have a thorough knowledge of the hazards and safety precautions, and that they follow the warning notices given in the eikon® e2s Installation and User manual, this Service manual and on the appliance. If you do not follow this safety code, you risk potentially fatal injury and property damage.

### Referring to the eikon® e2s Installation and User manual included in the customer documentation

- Read in full this chapter 'For Your Safety' and the chapters that relate to your work.
- Always keep to hand the manuals included in the customer documentation for reference.
- Pass on the user manuals included in the customer documentation with the microwave combination oven if it changes ownership.

#### CAUTION

##### Warning to Service Technicians:

Precautions to be observed before and during servicing to avoid possible exposure to excessive microwave energy.

1. Do not operate or allow the oven to be operated with the door open.
2. Make the following safety checks on all ovens to be serviced before activating the magnetron or other microwave source, and make repairs as necessary:
  - Interlock operation.
  - Proper door closing.
  - Seal and sealing surfaces (arcing, wear, and other damage).

- Damage to or loosening of hinges and latches.
  - Evidence of dropping or abuse.
3. Before turning on microwave power for any service test or inspection within the microwave generating compartments, check the magnetron, wave guide or transmission line, and cavity for proper alignment, integrity and connections.
  4. Any defective or misadjusted components in the interlock, monitor, door seal, and microwave generation and transmission systems shall be repaired, replaced, or adjusted by procedures described in this manual before the oven is released to the owner.
  5. A microwave leakage check should be performed on each oven prior to release to the owner.

## 2.2 Requirements to be met by personnel and working positions

### Requirements to be met by operating personnel

Personnel	Qualifications	Tasks
Service technician	Is an authorized service agent Has relevant technical training Is trained in the particular appliance Knows the regulations associated with handling heavy loads	All servicing and repair work

### Working positions during servicing and repairs

The service area for staff during servicing and repair work is the area around the appliance.

If it is not possible to obtain full access to all sides of the appliance move it to a better location following all manual handling recommendations.

## 2.3 Personal protective equipment

### Moving and setting up the appliance

Activity	Materials used	Personal protective equipment
Conveying within the establishment Setting up the appliance on a work surface, stand or in a stacking trolley. Setting up the appliance in the installation location	Suitable lifting gear Forklift truck or pallet truck	Protective gloves Safety boots Hard hat (e.g., when heavy loads are being lifted, working overhead, ...)

### Installation, preparing for first-time use and taking out of service

Activity	Materials used	Personal protective equipment
Installing and removing (taking out of operation) the electrical connection	Tools and equipment depending on the task	Work wear and personal protective equipment depending on the job that needs doing as specified in national regulations
Preparing the appliance for first-time use Instructing the user	Tools and equipment depending on the task	Workwear as specified in country-specific standards and directives for kitchen work, in particular:  Protective clothing  Heat protective gloves (compliant with EN 407 in European Union)  Safety boots



Dismantling the appliance (taking out of operation)	Suitable lifting gear Forklift truck or pallet truck	Protective gloves Safety boots Hard hat (e.g., when heavy loads are being lifted, working overhead)
---	---	---

## ■ Operation

Activity	Materials used	Personal protective equipment
Loading / removing food	None	Workwear as specified in country-specific standards and directives for kitchen work, in particular: Protective clothing Heat protective gloves (compliant with EN 407 in European Union) Safety boots
Removing and fitting parts	Tools and equipment depending on the task	Workwear as specified in country-specific standards and directives for kitchen work, in particular: Protective clothing Heat protective gloves (compliant with EN 407 in European Union) Safety boots

## ■ Cleaning

Activity	Materials used	Personal protective equipment
Cleaning the cavity by hand Handling spray bottles	Cleaning chemicals approved by the manufacturer Protective chemicals approved by the manufacturer	Items of protection equipment, depending on cleaning chemical being used: Breathing mask Safety goggles Protective gloves Protective clothing/apron The EC safety datasheet for the relevant cleaning chemical contains a more precise specification of these items. An up-to-date copy can be obtained from the manufacturer. Refer to the label on the cleaning chemical concerned.
Cleaning components and accessories according to relevant instructions	Common household detergent: mild on skin, alkali-free, pH-neutral and odourless	Follow the instructions given by the manufacturer of the cleaning chemical you are using
Cleaning the outside of the appliance	Common household stainless steel cleaner or hard surface cleaner	Follow the instructions given by the manufacturer of the cleaning chemical you are using

## ■ Repairs

Activity	Personal protective equipment
All repair work	Work wear and personal protective equipment depending on the job that needs doing as specified in national regulations

## 2.4 Intended use of the microwave combination oven

The microwave combination oven must only be used for the purposes specified below:

- The microwave combination oven is designed and built solely for cooking different foodstuffs in containers approved by the manufacturer. Microwave, convection and impingement are used for this purpose.
- The microwave combination oven is intended solely for professional, commercial use.

### Restrictions on use

Some materials are not allowed to be heated in the microwave combination oven:

- No dry powder or granulated material
- No highly flammable objects with a flash point of or below 275°C / 518°F, such as highly flammable oils, fats or cloths (kitchen cloths)
- No food in sealed tins or jars

### Requirements to be met by personnel

- The microwave combination oven must only be operated and installed by personnel who satisfy specific requirements. Please refer to section 2.2 'Requirements to be met by personnel and working positions' for the training and qualifications requirements.
- Personnel must be aware of the risks and regulations associated with handling heavy loads.

### Requirements relating to the operating condition of the microwave combination oven

Do not operate the microwave combination oven unless it has been properly transported, set up, installed and placed into operation as indicated in section 6 of the eikon® e2s Installation and User manual and the person responsible for placing it into operation has confirmed this.

- The microwave combination oven must only be operated when all safety devices and protective equipment are fitted, in working order and fixed properly in place.
- The manufacturer's regulations for operation and servicing of the microwave combination oven must be observed.

### Requirements relating to the operating environment of the microwave combination oven

Specified operating environment for the microwave combination oven:

- The ambient temperature lies between +4°C / 40°F and +35°C / 95°F
- Not a toxic or potentially explosive atmosphere
- Dry kitchen floor to reduce the risk of accidents

Specified properties of the installation location:

- No fire alarm, no sprinkler system directly above the appliance
- No flammable materials, gases or liquids above, on, under or in the vicinity of the appliance
- It must be possible to set up the microwave combination oven in the installation position so that it cannot tip over or slide about. The supporting surface must comply with these requirements.

Mandatory restrictions on use:

- The appliance must not be operated outdoors and not be shifted or moved during use.

### Cleaning requirements

- Use only cleaning chemicals that have been approved by the manufacturer.
- High-pressure cleaners or water jets must not be used for cleaning.
- The appliance must not be treated with alkali or acid solutions or exposed to acid fumes.

## 2.5 Warning signs on the microwave combination oven

### Warning and safety signs

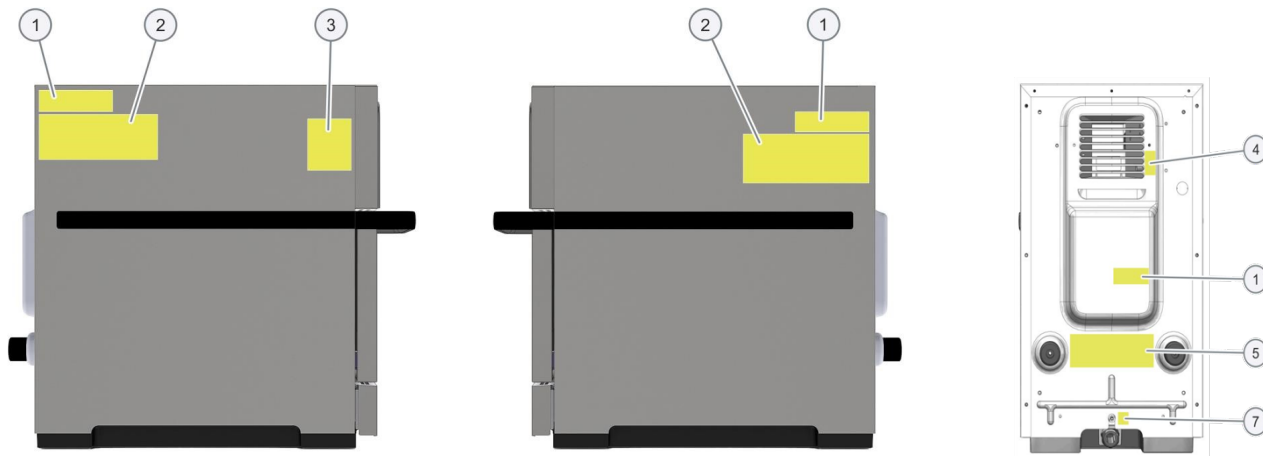





### Mandatory warning signs

The following warning signs / notices must be attached to the microwave combination oven and optional accessories in the area indicated so as to be easily visible at all times.

### Safety symbols

The following safety symbols be attached to the microwave combination oven in the area indicated so as to be easily visible at all times.

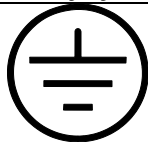
Area	Warning sign	Description
1	Microwaves warning. 	There is a risk of external and internal burns of body parts following exposure to microwave energy.
2	Electric shock warning	There is a risk of electric shock if the appliance is serviced without disconnecting the electrical supply.
3	Fire / electric shock warning	There is a risk of fire / electric shock if the appliance is operated without respecting the minimum clearances.
4	Hot surface warning 	There is a risk of burns from high temperatures inside the cavity and on the inside of the appliance door.
5	Electric shock warning	There is a risk of electric shock if the electrical power is not connected to a properly grounded outlet.

Area	Safety symbol	Description
6		Protective Earth (Ground)
7		Equipotential bonding

## 2.6 Safety devices

### Meaning

The microwave combination oven has a number of safety devices to protect the user from hazards. It is absolutely essential that all safety devices are fitted and in working order when operating the appliance.

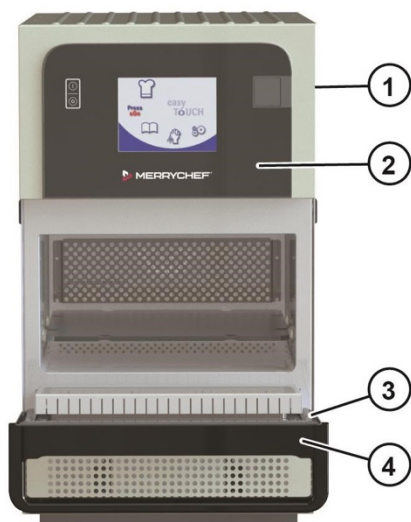

Item	Safety device	Function	Check
1	Panels can only be removed using a tool	Prevents live parts from being touched accidentally Prevents access to the moving fan from the wiring compartment	Check that the covers are in place
2	Operating panel can only be removed using a tool	Prevents live parts from being touched accidentally	Ensure that the operating panel is in place
3	Door seal	Protects the user and outside environment from microwave energy leaking from the cavity	Check the door seal regularly for signs of damage and replace it if required
4	Appliance door	Protects the user and outside environment from hot steam and microwave energy	Check the door regularly for damage and replace it if required
5 (no picture)	Door interlocks	Ensures that the microwave generation system cannot be powered when the door is open	Check door switches: Open the appliance door fully during pre-heat or when the oven is at temperature. The Door Open message is displayed
6 (no picture, installed by customer)	Disconnection device	Installed by the customer close to the appliance; easily visible and accessible, 1- or 3-pole action, minimum contact separation 3 mm. Used to disconnect the appliance from the power supply during cleaning, repair and servicing work and in case of danger	Trip the disconnection device
7 (no picture)	Internal fuses	Prevent faulty components from drawing too much current and causing potential fire hazard.	Ensure that the internal fuses are correctly rated
8 (no picture)	Internal high temperature thermostats	Prevent faulty components from generating too much heat and causing potential fire hazard	Ensure correct operation

## 2.7 Summary of hazards

### General rules for dealing with hazards and safety precautions

The microwave combination oven is designed to protect the user from all hazards that can reasonably be avoided by design measures.

The actual purpose of the microwave combination oven, however, means that there are still residual risks; you must therefore take precautions to avoid them. A safety device can provide you with a certain degree of protection against some of these hazards. You must ensure, however, that these safety devices are in place and in working order.

The nature of these residual risks and what effect they have are described below.

### Hazard points

The following illustration shows a Merrychef eikon® e2s microwave combination oven:

#### Excessive microwave energy

The microwave combination oven generates microwave energy. An operation with an open or damaged door or cavity can result in external and internal burns of body parts following exposure to microwave energy.

#### Heat generation (1)

The microwave combination oven becomes hot inside the cavity and on the inside of the appliance door. This poses a risk of burns on hot surfaces inside the microwave combination oven, and also on hot appliance parts, food containers and other accessories used for cooking.

#### Hot steam / vapour/ liquids (2)

When cooking food, the microwave combination oven may generate hot steam and vapour which escapes when the appliance door is opened, and which is removed through the air vents on the rear of the microwave combination oven when the appliance door is closed. This poses a risk of scalding from hot steam when the appliance door is opened. The operator must take particular care when opening the appliance door if the top door edge is below their field of vision.

Foodstuffs may also be liquid, or liquify during cooking. This poses a risk of scalding from hot liquids, which may be spilled if not handled properly.

#### Live components (3)

The microwave combination oven contains live parts. This means a risk from live parts if the cover is not in place.

#### Parts moving against each other (4)

For various actions, such as opening/shutting the appliance door or cleaning the appliance door, there is the risk that you will crush or cut your hand.

#### Contact with cleaning chemicals

The microwave combination oven must be cleaned using special cleaning chemicals. This poses a risk from cleaning chemicals, some of which can cause skin burns.

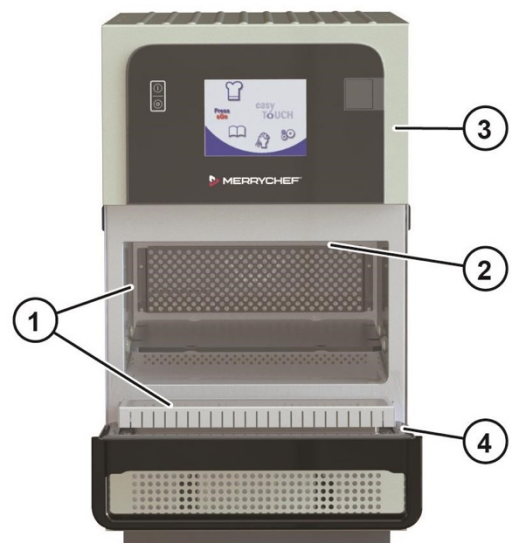

## 2.8 Hazards and safety precautions when setting up the appliance, during installation, preparing the appliance for use and cleaning

Please see the detailed information in section 3 'For your safety' in the eikon® e2s Installation and User manual.

3.6 Hazards and safety precautions when setting up the appliance

3.7 Hazards and safety precautions during installing

3.8 Hazards and safety precautions when preparing appliance for use

3.10 Hazards and safety precautions during cleaning

## 2.9 Safe working when working on the appliance

### ■ For your safety

Before starting work, familiarize yourself with the hazards described in section 3.6 'For your safety' in the eikon® e2s Installation and User manual.

### ■ Eligibility of personnel for working on the appliance

Only qualified Merrychef trained personnel from a Merrychef authorized service company are permitted to set up and work on the appliance.

### ■ Regulations for working on the appliance

Local and national standards and regulations relating to workplaces in catering kitchens must be observed. The rules and regulations of the local authorities and supply companies that apply to the installation location concerned must be observed.

### ■ Personal protective equipment

Wear the personal protective equipment specified in section 2.3 'Personal protective equipment'.

### ■ Moving heavy loads

#### **WARNING**

#### **Risk of injury from lifting incorrectly**

When lifting the appliance, the weight of the appliance may lead to injuries, especially in the area of the torso.

- Use a forklift truck or pallet truck to place the appliance in the installation position or to move it to a new position.
- When shifting the appliance into the correct position, use enough people for the weight of the appliance when lifting it (value depending on age and gender). Observe the local occupational safety regulations.
- Wear personal protective equipment.

### ■ Unsuitable supporting surface

#### **WARNING**

#### **Risk of crushing if the appliance tips over or falls off**

Body parts can be crushed if the appliance tips over or falls off.

Make sure that the appliance is never placed on an unsuitable supporting surface

## 2.10 Hazards and safety precautions during servicing and repair

### ■ Safety hazard: heat

Danger	Where or in what situations does the hazard arise?	Preventative action
A risk of burns	From hot surfaces such as Racks Containers, baking sheets, shelf grills etc. Inside the entire cavity, including all parts that are or were inside during cooking	Before starting cleaning tasks, wait until the cavity has cooled to below 50°C / 122°F or use the 'cool down' function to cool the cavity.
	On the inside of the appliance door	Wear specified protective clothing, in particular protective gloves.

## ■ Safety hazard: electrical power

 <b>Danger</b>	<b>Where or in what situations does the hazard arise?</b>	<b>Preventative action</b>
A risk of electric shock	Live parts: Under covers Under the control panel On the appliance and on adjacent metal parts On the appliance and on adjacent metallic accessories	Work on the electrical system must only be performed by qualified electricians from an authorized customer service company
		Before removing the covers: Switch off all connections to the power supply Take protective measures at every power switch to ensure that the power cannot be switched on again. Wait 15 minutes to allow the DC bus capacitors to discharge Make sure that the appliance is de-energized
		Make sure that the electrical connections are intact and fixed securely before plugging the appliance back into the power supply.
		Before putting the appliance back into use, make sure that the appliance, including all metallic accessories, is connected to an equipotential bonding system.

Dead working should be the normal method of carrying out work on electrical equipment or circuits. Live working should only be carried out in particular circumstances where it is unreasonable to work dead.

No person shall be engaged in any work activity on or so near any live conductor (other than one suitably covered with insulating material so as to prevent danger) that danger may arise unless;

- It is unreasonable in all the circumstances for it to be dead; and
- It is reasonable in all the circumstances for the service technician to be at work on or near it while it is live; and
- Suitable precautions (including where necessary the provision of suitable protective equipment) are taken to prevent injury.

When working on the oven it is important that the earthing of the power supply to the equipment is adequate and efficient. In customers' premises this is likely to be unknown, so it is important to carry out a test to demonstrate the efficacy of the earthing. The safe way to do this is to measure the earth loop impedance of the power supply using an instrument designed for that purpose. If the test indicates an inadequate earth, the customer must be informed that the work cannot continue until it has been rectified.

Simple 'Go/No go' plug-in testers will in general only provide a polarity check and an indication that an earth may be present, but not its effectiveness.

## ■ Safety hazard: mechanical parts of the appliance

 <b>Danger</b>	<b>Where or in what situations does the hazard arise?</b>	<b>Preventative action</b>
Risk of cuts from sharp edges	During servicing work When handling sheet-metal parts	Exercise caution when performing this action Wear personal protective equipment
Risk of body parts being crushed if the appliance tips over or falls off	When the appliance is being moved e.g., to gain better access to the connections	Always observe the requirements for the supporting surface

## ■ Safety hazard: moving heavyweights

 <b>Danger</b>	<b>Where or in what situations does the hazard arise?</b>	<b>Preventative action</b>
Risk of injury from overstressing your body	When moving the appliance	Use a forklift truck or pallet truck to place the appliance in the installation position or to move it to a new position Always use the correct number of persons and observe the limits specified for lifting and carrying when adjusting the appliance position Observe the local occupational safety regulations Wear personal protective equipment

## ■ Safety hazard: moving appliances supported on a wheeled base

 <b>Danger</b>	<b>Where or in what situations does the hazard arise?</b>	<b>Preventative action</b>
Risk of crushing of body parts	While appliances are being moved on a wheeled platform	When servicing, engage the parking brake on the wheels
Risk of hands and feet being pinched		
Risk of electric shock from live parts	While appliances are being moved on a wheeled platform	Disconnect the appliance from the electrical supply before moving it

## ■ Safety hazard: smoke or fire

 <b>Danger</b>	<b>Where or in what situations does the hazard arise?</b>	<b>Preventative action</b>
Risk of fire / smoke from defective electrical components or wrong electrical connections	If one of the electrical components is defect, for example due to a short circuit, or if the internal wiring is refitted incorrectly when servicing/repairing the oven	Never use electrical spare components which failed in a dedicated test or which bear visible damages Carefully refit electrical connections using the wiring diagrams provided in this manual

## ■ Safety hazard: electronic component damage

 <b>Danger</b>	<b>Where or in what situations does the hazard arise?</b>	<b>Preventative action</b>
Risk of electronic component damage within oven	The human body can store enough static electricity to damage the electronics within the oven, especially the QTS & SRB boards	When working on the QTS, or SRB, and associated wiring, anti-static precautions must be taken, such as wearing an ESD wrist strap. <b>IMPORTANT</b> - oven power supply and all capacitors must be proved dead first





## 2.11 Hazards and safety precautions when taking the appliance out of service

### ■ Safety hazard: electrical power

 <b>Danger</b>	<b>Where or in what situations does the hazard arise?</b>	<b>Preventative action</b>
A risk of electric shock	From live parts Under covers Under the operating panel	Work on the electrical system must only be performed by qualified electricians from an authorized customer service company

### ■ Safety hazard: moving heavyweights

 <b>Danger</b>	<b>Where or in what situations does the hazard arise?</b>	<b>Preventative action</b>
Risk of injury from overstressing your body	When moving the appliance onto and off the moving equipment	<ul style="list-style-type: none"> <li>▪ Use a forklift truck or pallet truck</li> <li>▪ Do not exceed safety limits for lifting and carrying</li> <li>▪ Wear personal protective equipment</li> </ul>

### ■ Safety hazard: mechanical parts of the appliance

 <b>Danger</b>	<b>Where or in what situations does the hazard arise?</b>	<b>Preventative action</b>
Risk of body parts being crushed if the appliance tips over or falls off	When the appliance is being moved e.g., to gain better access to the connections	Ensure oven is level and stable Always observe the requirements for the supporting surface when taking the appliance out of service; see section 3 'For your safety' in the eikon® e2s Installation and User manual
Risk of slipping on damp kitchen floor	In front of the appliance	Ensure that the floor around the appliance is dry at all times

## 2.12 Safe working during electrical installation

### ■ For your safety

Before starting work, familiarize yourself with the hazards described in section 3.7 'For your safety' in the eikon® e2s Installation and User manual.

### ■ Eligibility of personnel for the electrical installation

Only electricians qualified under the terms of EN 50110-1 and from an authorized service company are permitted to perform work on electrical equipment.

### ■ Regulations for the electrical installation

Observe the following requirement to prevent hazards caused by faulty electrical connections:

- The electrical supply must be connected in accordance with applicable local and national regulations and regulations of the professional associations and of the relevant power supply company.

### ■ Personal protective equipment

Wear the personal protective equipment specified in section 2.3 'Personal protective equipment'.

### ■ Live components

#### **DANGER**

#### **Risk of electric shock from live parts**

When the appliance is not connected to an equipotential bonding system, there is a risk of electric shock from touching live parts.

- Make sure that any work on the electrical system is performed solely by a qualified electrician from an authorized service company.
- Make sure that the electrical connections are intact and connected securely before putting the appliance into use.
- Before preparing the appliance for use, make sure that the appliance, including all metallic accessories, is connected to an equipotential bonding system.

Residual-current device (RCD)	The installation regulations require protection by a residual-current device (RCD). Suitable residual-current devices meeting the relevant national regulations must be used. If the installation includes more than one appliance, one residual-current device must be provided for each appliance.
Disconnection device	An easily accessible all-pole disconnection device with a minimum contact separation of 3 mm must be installed close to the appliance. The appliance must be connected via this disconnection device. The disconnection device is used to disconnect the appliance from the electrical supply for cleaning, repair and installation work.

### ■ Fitted frequency-converter

The appliance is fitted with one frequency converter (FC) and EMC mains input filters.

These devices may result in a leakage current of more than 3.5 mA per FC drive. Use a suitable RCD for the rated voltage.

### ■ Properties of the residual-current device

The residual-current device (RCD) must have the following properties:

- Filter for filtering out RF currents
- "Time delayed" trip characteristic for RCD devices with trip threshold of 30mA\*: prevents RCD being tripped by charging currents of capacitors and parasitic capacitances when appliance is switched on.
- "Leakage current protection, type SI" trip characteristic for RCD devices with trip threshold of 30mA\*: insensitive to nuisance tripping.
- \*Local national regulations may require lower trip ratings, such as in North America. In which case these lower trip threshold ratings must be adopted, ensuring the dedicated device has a high immunity to nuisance tripping.

Note. Residual Current Devices (RCDs) are also known by other terms, such as Earth Leakage Circuit Breakers (ELCBs), Safety Switches, Ground Fault Interrupters (GFIs) and Ground Fault Circuit Interrupters (GFCIs). These should not be confused with over current protection.

## 2.13 Electrical installation requirements

### Circuit Breakers (MCB ~ Miniature Circuit Breakers)

For over current protection, a Type 'D' circuit breaker (designed specifically for this type of equipment) must be fitted, as a recommend alternative a higher rated type 'C' type breaker can be used (see below). Establishments with standard (Type 'B') circuit breakers are sensitive to 'surges' which occur on switching on freezers, refrigerators and other catering equipment, including microwave combination ovens. An individual, suitably rated over current circuit breaker should be fitted for each appliance installed, along with a separate dedicated Residual Current Device (Ground Fault Circuit Interrupter).

Model	Recommended Circuit Breaker (per phase)	Alternative Recommended Circuit Breaker (per phase)
eikon e2s standard power	D16	C20
eikon e2s high power 1 phase	D32	C40
eikon e2s high power 3 phase	D16	C20

### Residual Current Device (RCD)

The installation regulations require protection by a Residual Current Device (Ground Fault Circuit Interrupter). Suitable residual current devices, with a high immunity to nuisance tripping, meeting the relevant national regulations must be used. As long cable runs can be a factor in nuisance tripping, they should be avoided.

If the installation includes more than one appliance, one residual-current (GFCI) device must be provided for each appliance.

### Low impedance electrical supply

This commercial combination microwave oven complies with EN 61000-3-11. However, when connecting sensitive equipment to the same supply as the appliance, the user should determine in consultation with the supply authority, if necessary, that a low impedance supply is used.

### Electrical supply

Illustration	Phase	Meaning
<p><b>SINGLE PHASE</b></p> <p>GREEN &amp; YELLOW (EARTH) BLUE (NEUTRAL) BROWN (LIVE)</p>	Single phase	<p>UK 13A models are fitted with a moulded plug to BS1363, fused at 13A.</p> <p>EU 16A models are fitted with a moulded plug to CEE 7/7 (Type F Schuko) rated at 16A</p> <p>30A models are fitted with a blue 32A plug to IEC 60309 (EN 60309).</p> <p>Connected to a dedicated RCD (GFCI) protected supply, with appropriate circuit breaker as detailed above.</p>
<p><b>TWIN PHASE</b></p> <p>GREEN &amp; YELLOW (EARTH) BLUE (NEUTRAL) BROWN TO LIVE No.1 BLACK TO LIVE No.2</p>	Twin phase	<p>Twin phase models should be connected as shown (the twin phase oven requires a three phase supply, utilising L1 &amp; L2 as two separate single phases, L3 is not used).</p> <p>30A models are fitted with a red 32A plug to IEC 60309 (EN 60309).</p> <p>EU 16A models are fitted with a red 16A 90° plug to IEC 60309 (EN 60309).</p> <p>Connected to a dedicated RCD (GFCI) protected supply, with appropriate circuit breaker as detailed above.</p>
	Single phase 60Hz (two pole)	<p>Single phase models, utilising L1 &amp; L2 split phase supply (240V) or L1 &amp; L2 from a three phase supply (208V). Neutral is not used.</p> <p>15A models are fitted with HBL5666C NEMA 6-15P &amp; 15A HBL4570C NEMA L6-15P plugs.</p> <p>20A models are fitted with a HBL5466C NEMA 6-20P plug.</p> <p>30A models are fitted with YP-91L NEMA 6-30P &amp; HBL2621 NEMA L6-30P plugs.</p> <p>Connected to a dedicated RCD (GFCI) protected supply, with appropriate circuit breaker as detailed above.</p>

Please refer to electrical installation data for other country specific models.

### Equipotential bonding

An equipotential bonding point is provided on the rear panel of the appliance for independent earth (not fitted to US models).



(GND) connection

### Example phase loading diagram

Loading per phase is not equal. Therefore, it is recommended to connect other electrical equipment to a separate L3+N from the mains supply.

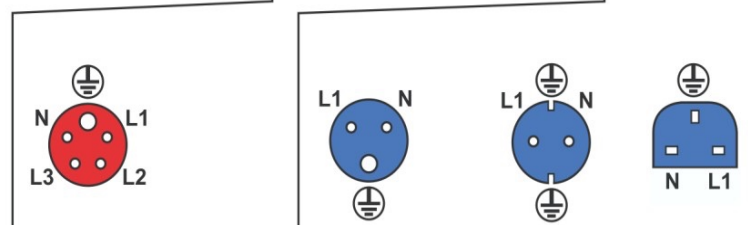
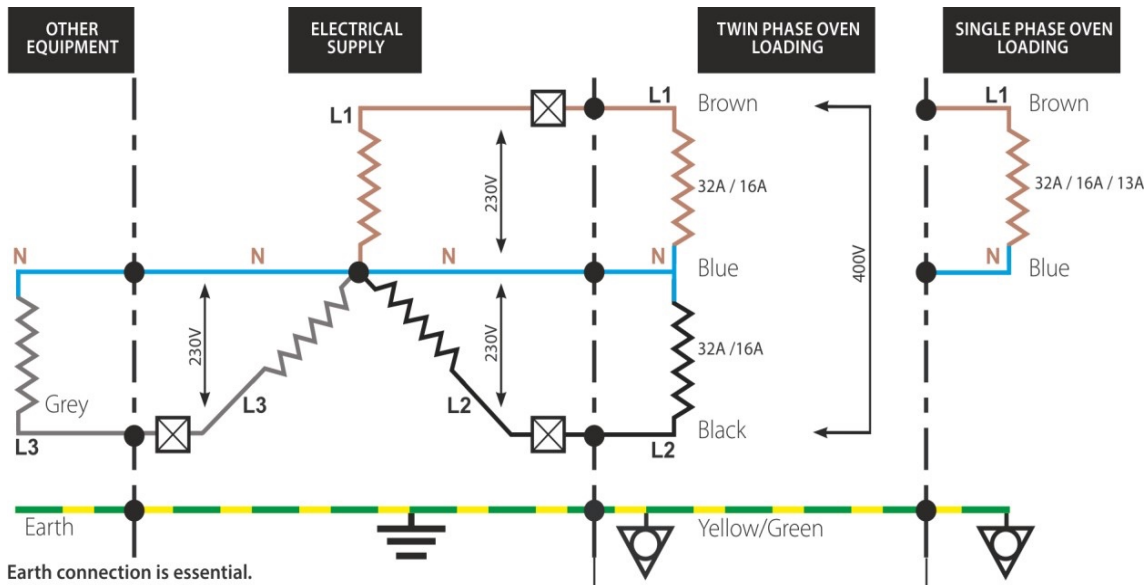

**RED**  
Rear view of plug  
Plug Type:  
Three Phase 32A  
IEC 60309  
[EN60309]  
L1+L2+N+E  
[L3 is not used]

**16A 'D'**

**BLUE**  
Rear view of plug  
Plug Type:  
Single Phase 32A  
IEC 60309  
[EN60309]  
L1+N+E

**EU plug**  
16A  
CEE 7/7  
(Type F  
Schuko)

**16A 'D'**

**UK plug**  
13A fused  
BS1363

**16A 'D'**

208V, Two Pole  
L1, L2 & E

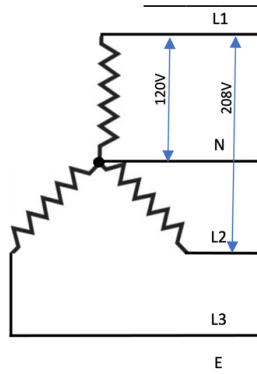

240V, Two Pole  
L1, L2 & E

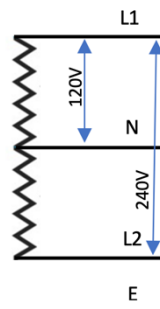

## 2.14 Safe working when testing components

### ■ For your safety when testing oven components

Before starting oven tests, it is essential that you familiarize yourself with the rules and hazard warning in this chapter and follow the instructions given.

### ■ Eligibility of personnel for testing oven components

Only qualified personnel from an authorized service company are permitted to test components of the microwave combination oven.

### ■ Moving heavy loads

#### **WARNING**

##### **Risk of injury from lifting incorrectly**

When lifting the appliance, the weight of the appliance may lead to injuries, especially in the area of the torso.

- Use a forklift truck or pallet truck to place the appliance in the installation position or to move it to a new position.
- When shifting the appliance into the correct position, use enough people for the weight of the appliance when lifting it (value depending on age and gender). Observe the local occupational safety regulations.
- Wear personal protective equipment.

### ■ Sharp-edged sheet-metal parts

#### **WARNING**

##### **Risk of cuts from sharp-edged sheet-metal parts**

Working with or behind sharp-edged sheet-metal parts may result in cuts to hands.

- Exercise caution.
- Wear personal protective equipment.

### ■ Hot surfaces

#### **WARNING**

##### **Risk of burns from high temperatures inside the cavity and on the inside of the appliance door**

- You may get burnt if you touch any of the interior parts of the cooking chamber, the inside of the appliance door or any parts that were inside the oven during cooking.
- Before starting servicing and repair work, wait until the cooking chamber has cooled to below 50°C / 122°F or use the 'Cool-down' function to cool the cooking chamber.
- Wear personal protective equipment.

### ■ Live components

#### **DANGER**

##### **Risk of electric shock from live parts**

When the appliance is not connected to an equipotential bonding system, there is a risk of electric shock from touching live parts. When the covers of the microwave combination oven are removed, there is a risk of electric shock from touching live parts.

- Make sure that any work on the electrical system is performed solely by a qualified electrician from an authorized customer service office.
- Before removing the covers:
  - Switch the appliance off and disconnect the plug from the wall socket.
  - Turn off the isolator switch to disconnect fixed wired appliances and lock-off.
  - Take protective measures at every power switch to ensure that the power cannot be switched on again.
  - Always discharge the high voltage capacitors before working on the appliance using a suitable Capacitor Discharge Tool, see section 2.15 'How to discharge the e2s HV'.
- Make sure that the appliance is de-energized.
  - Make sure that the electrical connections are intact, secure and all equipment panels are re-fitted before you reconnect the appliance to the power supply
- Before putting the appliance back into operation, make sure that the appliance, including all metallic accessories, is connected to an equipotential bonding system.

**■ Microwave emissions****⚠ WARNING****Risk of burns from microwave emissions**

- Do not become exposed to emissions from the microwave generator or parts conducting microwave energy.
- Never operate an appliance that has failed the "Microwave leakage test".

**■ Fire / smoke in the appliance****⚠ WARNING****Risk of fire and/or smoke**

Flames and/or smoke may come out of the oven when switching it on after service/repair. This can be caused by a defective electrical component or electrical connections (wiring) that have been refitted incorrectly.

- Switch off the oven.
- Disconnect/isolate the oven from the electrical supply.
- Keep the oven door closed to stifle any flames.

## 2.15 Process for discharging the capacitors:

### Tools required

Capacitor Discharge Probe  
Insulated Gloves  
Voltage tester—Checker

### Process for carrying out modification / change:



**1.** Cool down the oven then isolate from the mains supply by disconnecting the plug and fitting a suitable 'locking off' device or locking in the off position the isolation switch if the oven is hard wired. Ensure your proprietary voltage tester is working correctly and prove the mains supply is dead

**2.** Wait 5 Minutes to allow the Capacitor to naturally discharge its energy.

It is recommended that you stand on electrically safe matting where possible.

- Remove the lid and side panels to access the oven components
- Connect the Capacitor Discharge Probe's Earth clip to the Equipotential Bonding point at the rear of the oven

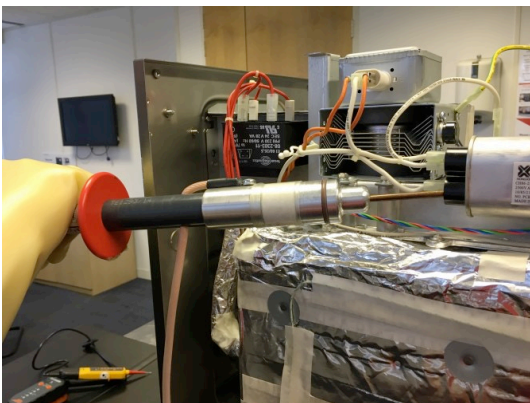

**3.** Hold the probe against the HV capacitor terminal for 5 seconds, removing any covers to do so. Repeat on the other set of terminals on the same capacitor. Repeat this process on both HV Capacitors with twin magnetrons.

**4.** Re-test your proprietary voltage tester is working correctly and test to ensure the capacitor is discharged (dead) at the magnetron(s) and the HV Transformer(s).

**CAUTION: To ensure safety, this must be repeated every time the oven is worked on.**

Note: the above picture shows the Merrychef Approved Capacitor Discharge Tool

## 2.16 Safe working when replacing appliance parts

### ■ For your safety when replacing appliance parts

Before starting service / repair work, it is essential that you familiarize yourself with the rules and hazard warning in this chapter and follow the instructions given.

### ■ Eligibility of personnel for removal / fitting of appliance parts

Only qualified personnel from an authorized service company are permitted to remove and fit components of the microwave combination oven.

### ■ Rules for setting up the appliance safely

To prevent hazards that arise from the installation site and environment of the appliances, the rules for setting up the appliance safely must always be observed; see section 5 'Setting up the appliance' in the eikon® e2s Installation and User manual.

#### **DANGER**

##### **Risk of electric shock from live parts.**

When the appliance is not connected to an equipotential bonding system, there is a risk of electric shock from touching live parts. When the covers of the microwave combination oven are removed, there is a risk of electric shock from touching live parts.

- Make sure that any work on the electrical system is performed solely by a qualified electrician from an authorized service company.
- Before removing the covers:
  - Switch the appliance off and disconnect the plug from the wall socket.
  - Turn off the isolator switch to disconnect fixed wired appliances and lock-off.
  - Take protective measures at every power switch to ensure that the power cannot be switched on again.
  - Always discharge the high voltage capacitors before working on the appliance using a suitable Capacitor Discharge Tool. See how to discharge the e2s in section 2.15 'How to discharge the e2s HV'.
- Make sure that the electrical connections are intact and connected securely before putting the appliance into use.
- Before preparing the appliance for use, make sure that the appliance, including all metallic accessories, is connected to an equipotential bonding system.

### ■ Moving heavy loads

#### **WARNING**

##### **Risk of injury from lifting incorrectly.**

When lifting the appliance, the weight of the appliance may lead to injuries, especially in the area of the torso.

- Use a forklift truck or pallet truck to place the appliance in the installation position or to move it to a new position.
- When shifting the appliance into the correct position, use enough people for the weight of the appliance when lifting it (value depending on age and gender). Observe the local occupational safety regulations.
- Wear personal protective equipment.

### ■ Sharp-edged sheet-metal parts

#### **WARNING**

##### **Risk of cuts from sharp-edged sheet-metal parts.**

Working with or behind sharp-edged sheet-metal parts may result in cuts to hands.

- Exercise caution.
- Wear personal protective equipment.



## Hot surfaces

### **WARNING**

#### **Risk of burns from high temperatures inside the cavity and on the inside of the appliance door.**

- You may get burnt if you touch any of the interior parts of the cooking chamber, the inside of the appliance door or any parts that were inside the oven during cooking.
- Before starting servicing and repair work, wait until the cooking chamber has cooled to below 50°C / 122°F or use the 'Cool-Down' function to cool the cooking chamber.
- Wear personal protective equipment.

## Microwave emissions

### **WARNING**

#### **Risk of burns from microwave emissions.**

- Do not become exposed to emissions from the microwave generator or parts conducting microwave energy.
- Never operate an appliance that has failed the "Microwave Leakage test".

## Fire / smoke in the appliance

### **WARNING**

#### **Risk of fire and/or smoke.**

Flames and/or smoke may come out of the oven when switching it on after service/repair. This can be caused by a defective electrical component or electrical connections (wiring) that have been refitted incorrectly.

- Switch off the oven.
- Disconnect/isolate the oven from the electrical supply.
- Keep the oven door closed to stifle any flames.

## 3 Technical data

### 3.1 Technical data charts

#### Dimensions and weights

Width				
Including packaging	535	[mm]	21.1	[in]
Appliance without packaging	356	[mm]	14.0	[in]
Height				
Including packaging	850	[mm]	33.5	[in]
Appliance ("Classic" exterior) without packaging	620	[mm]	24.4	[in]
Appliance ("Trend" exterior) without packaging	644	[mm]	25.4	[in]
Depth				
Including packaging	895	[mm]	35.3	[in]
Appliance without packaging, door closed	636	[mm]	25.0	[in]
Weight				
High power version, including packaging	70.4	[kg]	155	[lbs]
High power version, excluding packaging	61.0	[kg]	134	[lbs]
Standard power version, including packaging	61.1	[kg]	135	[lbs]
Standard power version, excluding packaging	51.7	[kg]	114	[lbs]
Safety clearances				
Right / Left	0	[mm]	0	[in]
Top / Rear (for ventilation)	50	[mm]	2	[in]

#### Electrical connected load ratings - High power version

Electrical supply		1N~ 220-230V 50Hz	2N~ 380-400V 50Hz	1N~ 220V 60Hz	2~ 200V 50/60Hz
Connections used		L + N + E	L1 + L2 + N + E	L + N + E	2P + E
Arrangement		Single phase	Twin phase	Single phase	Two pole
Rated power consumption	[W]	6000	2500 + 3300	6000	6000
Rated current per phase	[A]	32	16 / 32	32	32
Power output					
Rated power output convected heat	[W]	2200	2200	2200	2000
Rated power output microwave (IEC 705) 100%	[W]	2000	2000	2000	2000
Rated power output combination mode	[W]	2200 + 2000	2200 + 2000	2200 + 2000	2000 + 2000

#### Electrical connected load ratings - Standard power version

Electrical supply		1N~ 220-230V 50Hz	1N~ 220-230V 50Hz	1N~ 220V 60Hz	2~ 208V 60Hz
Connections used		L + N + E	L + N + E	L + N + E	2P + E
Arrangement		Single phase	Single phase	Single phase	Two pole
Rated power consumption	[W]	2990	3680	2860	4160
Rated current per phase	[A]	13	16	13	20
Power output					
Rated power output convected heat	[W]	2200	2200	2200	2200
Rated power output microwave (IEC 705) 100%	[W]	1000	1000	1000	1000
Rated power output combination mode (convected heat + microwave)	[W]	900 + 1000	1300 + 1000	900 + 1000	2200 + 1000

## Regulatory standards compliance

Degree of protection	IPX0
Noise emission	max. 70 [dBA]
Approval marks	
Tested safety	CE, CB (IEC)
Hygiene	UL-EPH (NSF/ANSI 4)

## Technical data, checks and verification

Description	Features	Function	Rating	Trouble shooting
Fuse	Glass	SRB ELV	1.25amp	Check continuity through fuse. Check fuse holder for cracks. Check for line potential on both terminals of fuse holder. Door Open message displayed when F2 has failed open circuit. No functionality when F3 has failed open circuit
Fuse F1	Ceramic Time Delay	Heating Circuit, supplies voltage to the SRB for the heating elements	20 Amp	
Fuse F2	Ceramic Time Delay	Microwave Circuit, supplies voltage to the HV components through the interlock switches	20 Amp	
Fuse F3	Ceramic BS1362	Control Circuit supplies voltage to the LV transformer	13 Amp <i>*(12 Amp see note 1)</i>	
Door Interlock Switches	Common, Normally Open and Normally Closed terminals; RHS SW1 Monitor (inner C to NC) RHS SW2 Secondary (outer C to NO) LHS SW3 Primary (C to NO) Door Open message displayed when SW3 is open	Door switches are for safety and they prove the oven door is physically closed or open. The microwave circuit will not be energized if the door is open. L2 runs through these switches. Sequence: When opening the door: SW3 opens first, then SW2 opens, lastly SW1 closes. When closing the door: SW1 opens first, then SW2 closes, lastly SW3 closes	SW1 & SW2: 250VAC 22A SW3: 250VAC 20A (up to 75A inrush)	Check F2 Check for continuity Check for proper wiring Check for proper adjustments Check for physical damage such as bent activating tabs (see section 6.11 'Adjusting the door') Check SRB connections X10, X4a and X102b Check SRB LED Check for line potential on SW3 NO
Voltage Selection Relay(s)	Receives line voltage at the C terminal. When the coil of the relay is energized the output will be at the NO terminal. Without the coil energized, the output will be at the NC terminal. The SRB energizes the coil when the mains supply voltage is <218VAC. One Relay fitted as standard, two Relays fitted to High Power oven versions.  <i>* not fitted to JP models</i>	Supplies correct voltage to the HV transformer at the primary winding terminals. Output from NC: Wired to HV transformer's 230V (*240V) primary winding. Output from NO: wired to HV transformer's 200V (*208V) primary winding. Mains voltage continually checked, relay energised/deenergised when door is open and then closed.	Switched Voltage: 200/230VAC <i>*(208/240VAC see note 2)</i>  Coil 12VDC / 255Ω	Check SRB plug connection X101, X4b and X102b Check for proper wiring. Check mains supply voltage in 'Visual View' if voltage is above 218VAC the relay should be de-energised (12VDC not present at coil with switched C connected to NC).

Description	Features	Function	Rating	Trouble shooting
<p>EMI Filters (Mains Filters)</p> <p>*Note: JP model has three filters. Using the standard mains filter for F2 and a larger mains filter, fitted above, for F1 &amp; F3. The third, standard size filter, is located to the left of the HV transformer for the VFD mains supply.</p>	Filters unwanted frequency noise from interfering with various circuits and components in the oven	For use on the main supply feeding all branch circuits.	<p>250VAC 20A @ 40°C Line (L&amp;N) or Load (L'&amp;N') = 330kΩ L1 (L&amp;L') or L2 (N&amp;N') = 0Ω Ground (G&amp;L), (G&amp;N), (G&amp;L'), (G&amp;N') = open</p> <p>*JP model (large filter) 250VAC 50/60Hz / 250VDC, 20A @40°C Line (L&amp;N) or Load (L'&amp;N') = 222kΩ L1 (L&amp;L') or L2 (N&amp;N') = 0Ω Ground (G&amp;L), (G&amp;N), (G&amp;L'), (G&amp;N') = open</p>	<p>Check for signs of overheating or discolouration.</p> <p>Check for shorts to ground from all Live and Neutral terminals.</p> <p>Check for steady voltage (Live &amp; Neutral) to the filter.</p> <p>Check for steady voltage (Live &amp; Neutral) out of the filter</p>
ELV Transformer (Low Voltage Transformer)	<sup>3</sup> / <sub>16</sub> " spade connections on primary winding and <sup>1</sup> / <sub>4</sub> " spade connections on secondary winding	Provides a step down voltage of 24VAC to the Smart Relay Board for controller operation. This 24VAC is supplied to the DC rectifying circuit on the SRB	<p>Primary Voltage 230VAC Secondary Voltage 24VAC / 28VA @ 70°C. Resistances: Primary = 81Ω, Secondary = 1.3Ω</p>	<p>Check for opens, shorts or grounds</p> <p>Check resistance of windings</p> <p>Check SRB connections X103, X103.1, X1 and fuse</p> <p>Check for lit LED's on SRB</p> <p>Check primary winding voltage</p> <p>Check secondary winding voltage.</p>
On/Off Switch	On/Off Switch PCB toggle	Provides a 12VDC return to the Smart Relay Board to activate oven functions	<p>Switched Voltage: 12VDC Rating: 6A / 12V Resistance: If open O.L., if closed = 0Ω</p>	<p>Check continuity through switch.</p> <p>Check for 12VDC through switch.</p> <p>Check for firm clicking sound when switching on and off.</p> <p>Check SRB connection X18a for security</p> <p>Check Error Log for E86 events</p>
<p>Cooling Fan</p> <p>*Note: JP model has a different fan</p>	Supplies fresh air into the component chamber to cool down the electrical components. The fan should run counter clockwise (looking down from above). The fan will continue to run once the oven is switched off, until the cavity temperature drops below 50°C ("Shutting down" displayed). Motor has internal Thermal Overload Protection on the Live	Supplies fresh air into the component chamber to cool down the electrical components. fan should run counter clockwise. Draws air in through the filter under the door and out the rear of the oven	<p>230VAC 0.23A 52W @ 50Hz. Resistance: 190 - 210Ω (205Ω across connection terminals). Capacitor 1.5μF</p> <p>*JP Model 200VAC 50/60Hz, 0.33/0.4A, 62/67W. Resistance: 125Ω &amp; 167Ω (125Ω across connection terminals). Capacitor 3μF</p>	<p>Check for opens, shorts or grounds</p> <p>Check for locked rotor (Power Off)</p> <p>Check SRB connection X8</p> <p>Check SRB LED</p> <p>Check for Live supply potential on fan connection</p> <p>Check Error Log for SRB &amp; QTS temperatures and E103 events</p>

Description	Features	Function	Rating	Trouble shooting
Cooling Fan Capacitor  *Note: JP model has a different cooling fan	Connects to the cooling fan using a terminal block	Stores and discharges voltage to start and run the cooling fan motor	400V, -25/70°C, 1.5μF ±5%  *JP Model 400-500V, -40/85°C, 3μF ±5%	Check for proper microfarads. Check for opens, shorts, or grounds. Warning: Capacitor may have a stored charge, discharge before testing
Stirrer Motor(s)	Mounts directly on the wave guide above the cavity, supply voltage connected directly from the SRB. Driving the stirrer antennae in the horn area of the microwave launch on the cavity, through the gear assembly	Drives a stirrer antennae to evenly distribute or scatter microwaves into the oven cavity	230VAC 2.7W. Resistance 7 - 8Ω	Check for opens, shorts or grounds Check for locked rotor (Power Off) Check SRB connection X20 Check SRB LED Check for Live supply potential at SRB X20 connection
VFD (Motor Speed Controller)	Takes 1PH AC supply voltage and produces a 3PH DC square wave frequency output	Provides an DC, 3-phase switched mode drive to the AC convection motor and is controlled by a 0-5 VDC signal from the relay board (SRB). The frequency output allows the Main Blower Motor to run at variable speeds	1ph power supply. Control Signal Voltage 5VDC output to SRB, 1-5VDC return to determine speed percentage of convection fan motor (1-3.7VDC on 16A/13A ovens). Output 3ph DC square wave frequency voltage	Check electrical connection Check SRB connections X3 & X9 Check SRB LED Check PWR & ST LED's. Check for 5VDC at pins P1 (Blue) & P3 (Green). Check for 1-5VDC at pins P2 (Red) & P3 (Green) Check Live supply potential on VDF Check for consistent output voltage between each phase between Black, Brown and Blue (Digital multi-meter should be set to VAC to do this check) Check Error Log for E106 events
Convection Motor	The convection motor is a 3-phase AC motor that runs at variable speeds and is powered by a motor speed controller (VDF Drive). The windings are thermally protected (two grey wires). The fan will continue to run once the oven is switched off, until the cavity temperature drops below 50°C ("Shutting down" displayed)	Provides variable percentages of airflow that is heated into the oven cavity used for accelerated cooking. This is the convection and impingement process.	Supply Voltage: DC square wave frequency that simulates 3ph voltages up to 220V at 100% Resistance: 9Ω ±10% across windings	Check for opens, shorts or grounds Check for locked rotor (Power Off) Follow VFD Drive Trouble shooting checks.

Description	Features	Function	Rating	Trouble shooting
Convection Motor IP	Thermal Switch within the Convection Motor. Two grey wires. Normally Closed, monitors convection fan motor internal temperature. Opens when the motor gets too hot	Breaks control safety circuit control voltage signalling SRB to de-energise heating and microwave circuits based on the temperature inside convection fan motor windings. The oven shuts down and displays E104 or OVERHEAT warning (E115) during a cook cycle with microwave.	Switched Voltage; 12VDC Resistance if open O.L., if closed = 0Ω Opens at 150°C (300°F)	Check continuity through switch. Check SRB connections & plugs on X18c, X18d, X18e and convection fan motor IP connections. Follow Convection Motor Trouble shooting checks
Overheat Thermostat (Over Temp Stat / Cavity Stat)	Manual reset, capillary tube, normally closed, monitors cavity temperature. Opens when the cavity temperature gets too hot	Breaks control safety circuit control voltage signalling SRB to de-energise heating and microwave circuits based on the temperature inside oven cavity. The oven shuts down and displays E104 or OVERHEAT warning (E115) during a cook cycle with microwave.	Switched Voltage; 12VDC. Resistance if open O.L., if closed = 0Ω. Opens at 300°C (570°F) [310°C cavity temperature]	Check continuity through switch. Check for 12VDC on both sides of switch. Terminals are normally closed, if open, reset thermostat and test oven for proper operation Check SRB connections & plugs on X18c, X18d, X18e. Check convection fan motor IP. Check SRB LED
Magnetron Limit Stat(s)	Automatic reset. Monitors surface temperature. Normally Closed, opens when the magnetron surface temperature gets too hot	Breaks control safety circuit control voltage signalling SRB to de-energise heating and microwave circuits based on the temperature of the magnetron case. The oven shuts down and displays E104 or OVERHEAT warning (E115) during a cook cycle with microwave.	Switched Voltage; 12VDC. Resistance if open O.L., if closed = 0Ω. Opens at 125°C (257°F), automatically closes once magnetron case temperature drops to 80°C (177°F)	Check continuity through switch(es). Check for 12VDC on both sides of switch(es). Allow magnetron to cool before testing. A dirty air filter is a major root cause of this failure Check SRB connections & plugs on X18c, X18d, X18e Check convection fan motor IP. Check SRB LED
Heating Element	Sheath resistive heating element, sealed terminal ends.	Provides heat for the oven cavity. When air passes over the surface, heat is transferred into the air.	Supply Voltage 230VAC pulsed from SRB to control power (wattage). Resistance: 19Ω between terminals, (any terminal to ground: open). Maximum power 2200W and 9-10A at 230VDC	Check F1 Check Neutral connections, EMI Filter. Check resistance ratings. Check SRB terminal connections X2.1 & X2.2. Check current draw on 'Visual View' Check for opens, shorts & grounds. Check SRB LED

Description	Features	Function	Rating	Trouble shooting
				Check Live supply potential at heater terminals Check Error Log for E102 & E116 events
Magnetron(s)	One Magnetron fitted as standard, two Magnetrons fitted to High Power oven versions	Provides microwave energy, 0 to 100%, through the waveguide(s) into the oven cavity for accelerated cooking.  At 50% power the microwave circuit cycles 20 seconds on / 20 seconds off	1000W per magnetron, 7-8A at 230VDC. See HV Components in Section 5.8 for further rating information. (NOT TO BE TESTED LIVE)	Follow all test procedures in Section 5.8. Check for opens, shorts & grounds. Check SRB connections X4a, X102b, X102a. Check SRB LED Check Error Log for E101 & 113 events
HV Transformer(s)	One HV Transformer fitted as standard, two HV Transformers fitted to High Power oven versions, wired out of phase with each other.	Provides both the stepped down and stepped up Voltages for the for the Magnetron(s)	Primary winding: 200 / 230 VAC. Secondary winding to Magnetron Filament = ELV, and approximately 1:10 stepped up High Voltage for microwave circuit (NOT TO BE TESTED LIVE). See HV Components in Section 5.8 for further rating information.  *(208 / 240 VAC see note 2)	Follow all test procedures in Section 5.8. Check for opens, shorts & grounds Check SRB connections X4a, X102b, X102a. Check SRB LED Check Error Log for E101 & E113 events
HV Capacitor(s)	One HV Capacitor fitted as standard, two HV Capacitors fitted to High Power oven versions.  Internal discharge resistor.	In conjunction with the HV Diode(s) to double the stepped up voltage from the HV Transformer(s)	2,500 VAC, 1.20 $\mu$ F $\pm$ 3%. See HV Components in Section 5.8 for further rating information (NOT TO BE TESTED LIVE)  *(0.95 $\mu$ F & 1.0 $\mu$ F see note 3)	Follow all test procedures in Section 5.8 Check for opens, shorts & grounds Check SRB connections X4a, X102b, X102a. Check SRB LED Check Error Log for E101 & 113 events
HV Diode(s)	One HV Diode fitted as standard, two HV Diodes fitted to High Power oven versions.	In conjunction with the HV Transformer(s) to double the stepped up voltage from the HV Transformer(s), for the Magnetron DC supply	See HV Components in Section 5.8 for further rating information (NOT TO BE TESTED LIVE)  16kV, 750mA (up to 50A surge) -20°C to +135°C	Follow all test procedures in Section 5.8 Check for opens, shorts & grounds Check SRB connections X4a, X102b, X102a. Check SRB LED Check Error Log for E101 & 113 events
Thermocouple	Provides DCmV to the Smart Relay Board (SRB) that represents the cavity temperature	Two dis-similar metals connected at the tip that produce different repeatable millivolts while exposed to different temperatures.	See chart below for reference E111 error when open circuit fault exists.	Check resistance for open probe. Check DC voltage between wires. Use chart based on 25°C(77°F) ambient

Description	Features	Function	Rating	Trouble shooting
		Green (or Red on some models) is negative, and White (or Yellow on some models) is positive.		temperature to verify proper reading. Check for opens, shorts or grounds.

K Type Junction at 25°C ambient (1VDC = 1,000mVDC)					
°C	mVDC	(°F)	°C	mVDC	(°F)
0°C	0	(32°F)	125°C	5.1	(257°F)
25°C	1	(77°F)	150°C	6.1	(302°F)
50°C	2	(122°F)	200°C	8.1	(392°F)
75°C	3.1	(167°F)	250°C	10.2	(482°F)
100°C	4.1	(212°F)	300°C	12.2	(572°F)

\*Note 1: 12A fuse (F3) used in Americas

\*Note 2: 208/240 HV Transformers used in most 60Hz applications

\*Note 3: 0.95µF Capacitors used in most 60Hz applications. 1.0µF Capacitors used in specialised applications

Always review country specific service parts lists for required replacements. Never use non-approved alternatives.

See section 6.19 for the Technical Data Summary Sheet

### 3.2 Dimensional drawings

#### eikon® e2s

Front view (door closed)

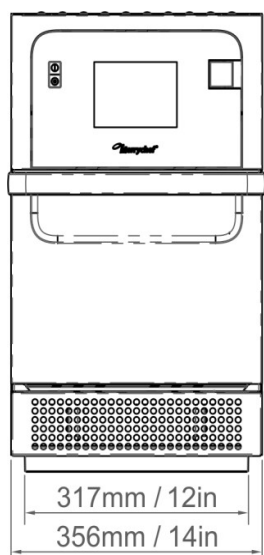

View from the top (door closed)

Cavity dimensions (door closed)

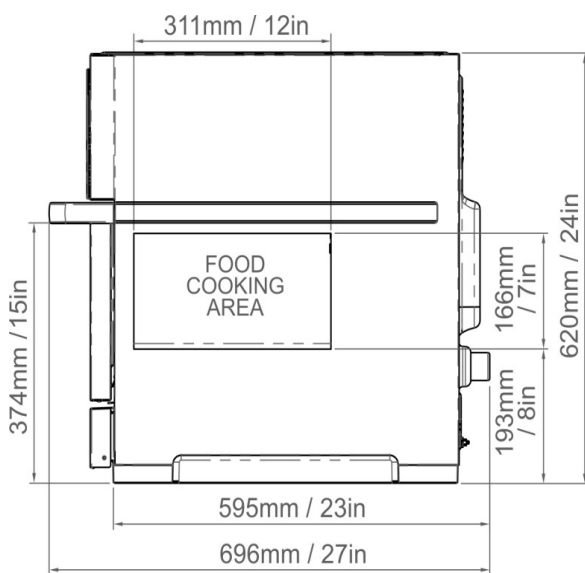

View from the right hand side (door open)



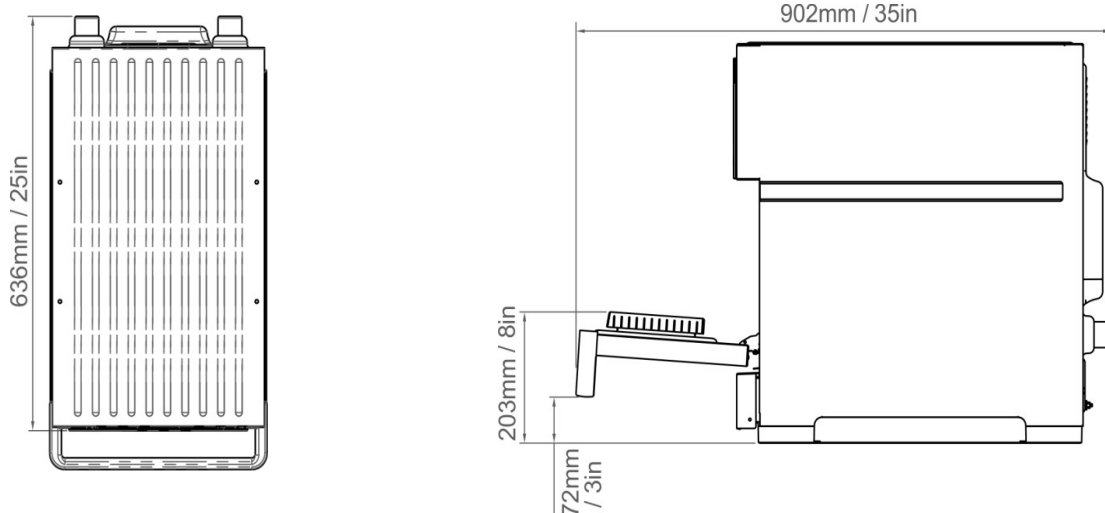

## 4 Accessing the easyTouch® screen

### Purpose





Instruct the user regarding all safety-related functions and devices.  
 Instruct the user in how to operate the appliance.

### 4.1 Main menu screen

### Appearance



### The buttons and what they do

Button	Meaning	Function
	Development Mode or Manual Cooking Mode	'Development Mode' enables multistage cooking profiles to be developed, then stored under a name and symbol for reuse. 'Manual Mode' enables multistage cooking without the need for a pre-programmed cooking profile.
	Press&Go	'Press&Go' allows quick access to use the cooking profiles that are already stored.
	Cookbook	'Cookbook' contains the cooking profiles stored in the memory of the appliance. It displays favourites, cooking profile groups and a complete listing of all cooking profiles available.
	Cleaning / Temp change	'Cleaning / Temp change' allows the cavity temperature to be changed and the appliance to be prepared for cleaning with reminders displayed to assist during the cleaning process.
	Settings	'Settings' are used to control the appliance settings and functions including time and language, loading cooking profiles and for service and maintenance purposes.

## ■ The easyTouch® screen display

The easyTouch® screen display, layout and icons shown herein are for guidance purposes only and are not intended to be an exact representation of those supplied with the appliance.

Full operational details can be found in the Installation and User Manual.

## 4.2 The keyboard screen

### ■ Appearance



### ■ The buttons and what they do

Button	Meaning	Function
	Keyboard screen	The keyboard screen is used to enter an authorised password to enter data for programmes and may restrict operator access to some functions.
	Clear screen	Select the 'clear screen' key to delete text from the keyboard screen.
	Keyboard	Type in text using the keyboard.
	Spacebar	Select the 'spacebar' key to insert a blank.
	Return	Select the 'return' key to start a new line.
	Keyboard scroll	Select the up/down arrows to scroll the keyboard screen.
	Enter / OK	Select the green check mark to confirm settings and continue.
	Previous screen	Select the 'backspace' key to return to a previous screen.

### ■ Character length

For names of cooking profiles, names of cooking profile groups and passwords use 1-20 characters in 2 lines max. For stage instructions of individual cooking profiles use 1-54 characters in 5 lines max.

Full operational details can be found in the Installation and User Manual.

### 4.3 Cleaning procedures

**IMPORTANT**  
Cool down the oven before



**You will need**

**PPE:**

- heat proof gloves
- protective rubber gloves
- eye protection

**Cleaning materials:**

- non-abrasive nylon scrub pad
- cleaning cloths
- Merrychef oven cleaner (or Merrychef approved cleaning chemicals)
- Merrychef oven protector

**Cool down the oven**



**1.** Press the hand icon from the main menu (full serve mode) or the blue thermometer icon (quick serve mode).

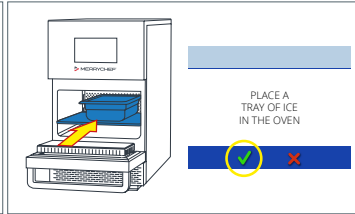

**2.** Place a pan of ice into the oven to speed up the cool down process. Press the green tick.

**⚠ Do not leave the pan of water in the oven overnight.**

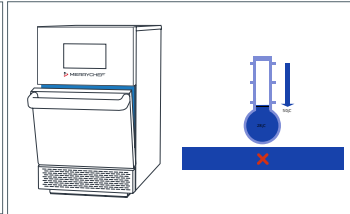

**3.** Leave the door open slightly. Wait for temperature to reduce to 50°C or 122°F. This takes approximately 20 mins.

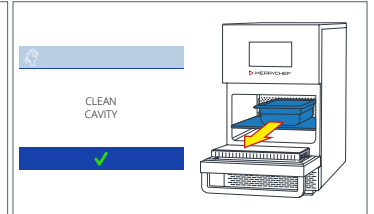

**4.** Once the cooling process is complete you will see a 'clean cavity' screen. Remove the pan of water. The oven is now ready for cleaning.

**⚠ Pan and water may be hot. Use heat proof gloves.**

**Clean the cold oven**

**⚠ Wear PPE**

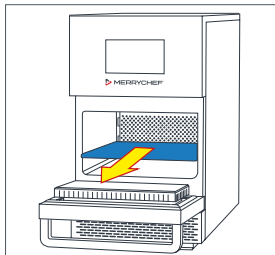

**1.** Remove the cook plate and any other cooking accessories from the cavity.



**2.** Wash all parts in warm soapy water using a sponge. Rinse off and dry using a clean cloth. Remove any spillages with a suitable cloth or paper towel.

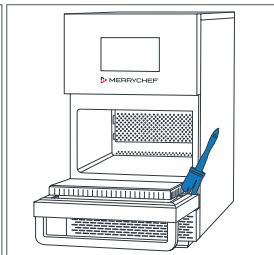

**3.** Use a dry clean brush to remove any food particles from between the cavity floor and the inside of the front door.

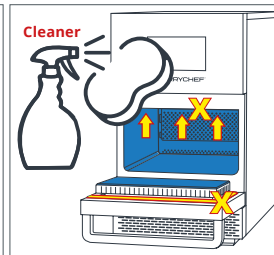

**4.** Spray Merrychef approved cleaner onto a sponge and wipe onto the sides of the inside of the oven, the back, the base and the oven door. Avoid the roof and door seal

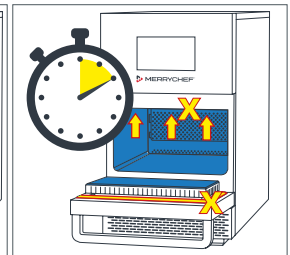

**5.** For difficult areas, leave to soak for 10 minutes with the oven door open. Clean the cavity using a non-abrasive sponge. Again, avoid the roof and do not scrub the door seal.

**⚠ Do not spray directly into the cavity. Avoid the roof and door**

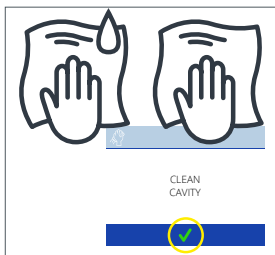

**6.** Remove the Merrychef cleaner with a clean wet cloth. The cavity roof and door seal can also be gently wiped if necessary, to remove food debris. Dry the oven with a clean dry cloth. Press the tick on the 'clean cavity' screen to

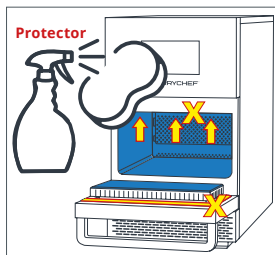

**7.** Apply oven protector (optional). Spray Merrychef Protector onto a sponge and spread lightly onto the sides of the inside of the oven, the back, the base and the oven door and heat oven afterwards.

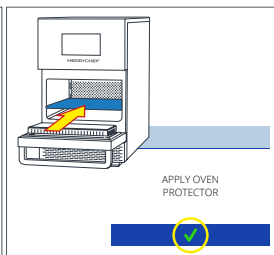

**8.** Replace the cook plate and press the green tick to continue.

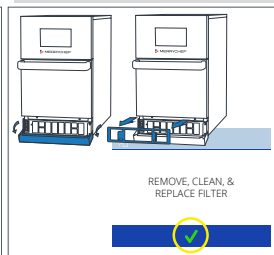

**9.** Remove the air filter and wipe it clean or wash in soapy water. Dry and replace and then press the green tick to continue.



**10.** Switch the oven off. Wipe the outside of the oven with a clean sanitised cloth.

**⚠ Avoid the roof and door seal. Heat oven to cure the protective chemical.**

**WARNING: Do not use the oven without a clean filter in place. Do not use caustic cleaners in the oven cavity as they cause permanent damage to the catalytic converters. Do not use tools, sharp implements or harsh abrasives on any part of the oven.**

## 4.4 Using a USB stick

### Purpose of the USB cover

The USB cover protects the USB port so that no water vapour can get into the control electronics during cooking or cleaning. During cooking and cleaning, there must not be a USB stick inserted and the USB port must be closed by the cover.

### USB programs (Menus)

#### IMPORTANT:

Downloading from a USB memory stick will clear all the existing programs in the memory of the appliance.

Check that the key has the correct number/code for the programs you want to load into the memory and the automatic update file (1 '.cbr' + 'autoupd.ate').



1. Switch the appliance OFF.

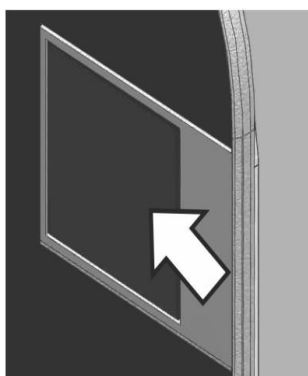

2. Open the cover to the USB port on the control

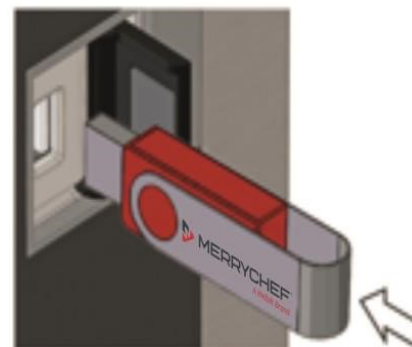
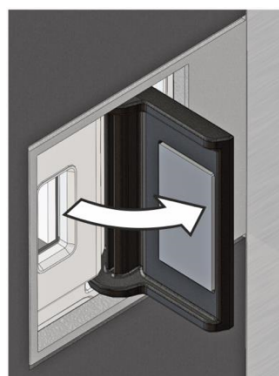

3. Plug in the USB memory stick.  
If the USB memory stick is too large, use a standard commercial adapter



4. Switch the appliance ON.

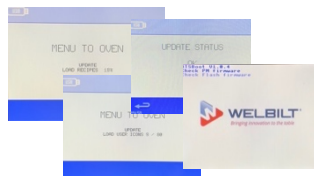

5. The files automatically download from the USB memory stick showing the progress and confirmation screens for the update.

On completion the appliance displays the start up screen.

The oven then preheats or displays a preheat temperature choice.

Remove the USB memory stick and keep it in a safe place.

## 4.5 Firmware updates

### Overview

#### Firmware updates

There are three firmware files required for the e2s: QTS, SRB and Icon. All firmware files are pre-installed but may require updating as per instruction from the manufacturer or as part of hardware replacement. Firmware files are updated by loading the required files to a USB memory stick and then downloading this information to the appliance using the USB memory stick slot on the oven.

#### Procedures to load USB sticks and download to appliance

#### Important notes:

- Downloading from a USB memory stick will clear all existing programs.
- Only use an empty USB memory stick formatted as FAT32.
- Copy the following firmware files to the ROOT directory of the USB memory stick:
  - QTS-e2s-VXXX-VX.X.XX.bin
  - XXX.XXX.XXX\_e2s\_SRB\_APP.bin
  - VX-APP-e2s.cbr (icon file)
  - autoupd.ate (for auto update only)
- Ensure USB memory stick is 'ejected' from computer after loading files, not just unplugged as files may be corrupted.
- Do not attempt to read firmware files on a computer as files may be corrupted.
- Only use the Menuconnect operating program to read menu files on a computer as files may be corrupted.
- The USB memory stick should be formatted to FAT32 with firmware loaded.
- Do not remove the USB memory stick during the download sequence as this could corrupt the data transferred from the USB stick.
- Save the menu files before uploading files.
- If you have a menu file on your USB memory stick, then the menu of the appliance will be overwritten.
- If you do not have file on your USB memory stick the menu of the appliance stays as it is.

There are two methods for installing firmware files: manual or automatic. The recommended automatic method is the simplest method as it ensures that all three firmware files have been updated at the same time.

For automatic update ensure the autoupd.ate file is on the USB memory stick then follow the instructions in the automatic updates using following autoupd.ate files section.

For manual update follow all instructions in the following manual updates section.

**Automatic updates using autoupd.ate files**

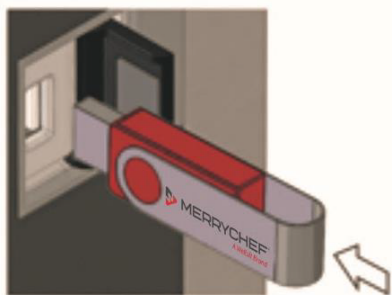

**1.** Load the USB stick with the autoupd.ate file. Copy the following firmware files to the ROOT directory of the USB memory stick:

- QTS-e2s-Vxxx-xxx.xxx.bin
- xxx.xxx.xxx\_e2s\_SRB\_APP.bin
- Vx-APP-e2s.cbr
- Menu.cbr (if required)
- autoupd.ate

With the oven switched OFF, open the cover of the USB port and insert the USB memory stick into the slot.



Note: the autoupd.ate file will not allow automatic downloading on to the oven of older versions of the QTS or App files. If necessary, these can still be loaded manually.

**2.** Switch ON the oven.

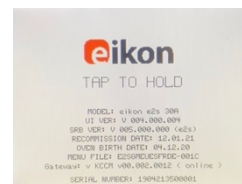

**3.** The firmware starts downloading. Download progress from the USB memory stick is displayed followed by the update status and confirmation screens.

**4.** The QTS, SRB, (Menu file if included on USB) and application icon files then download automatically showing the progress, status and reboot confirmation screens for each file update. **DO NOT SWITCH THE OVEN OFF UNTIL COMPLETE**

**5.** On completion the start up screen is displayed showing the updated firmware versions and menu file before moving to the pre heat temperature screen

**Confirming the firmware update**

After an update of the appliance firmware certain information is copied back to the USB memory stick.

You can check if the file transfer was successful with the following procedure:

1. View the USB memory stick on a computer.
2. Open the update (UPDATE.LOG) file.
3. A firmware (or menu) update is confirmed below the serial number of the appliance with 'updated' following the QTS, SRB, Menu and APP icons files.

Note: The same files will not load on the same oven again unless the update.log file is removed from the USB key.

Load only one of each of the oven specific files onto the USB memory stick:

- QTS-e2s-Vxxx.xxx.xxx.bin
- xxx.xxx.xxx\_e2s\_SRB\_APP.bin
- Vx-APP-e2s.cbr
- Latest menu xxxxxxxxxxxxxxx.cbr
- autoupd.ate



**Load only the correct complete menu file onto the USB memory stick and not a single cook menu.**

**PM (Personality Module) replacement - firmware update**

The personality module on the SRB contains the SRB firmware and error log file

The personality module on the QTS contains the QTS firmware, serial number of your appliance, temperature calibration, cooking profiles, application icons and the recipe images.

Firmware may have to updated on replacement of Personality Module. The operator’s menu file will have to be reloaded on replacement of the QTS PM. Procedures as covered in this section (4.5) should be followed.

See section 6.10 for replacing components

**Manual updates**

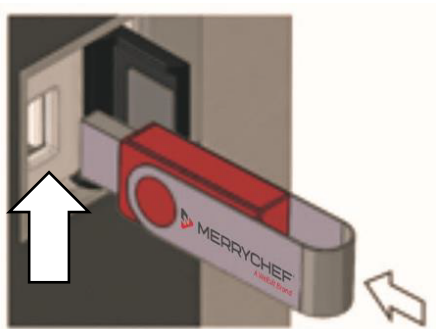

**1.** With the oven switched off, open the cover of the USB port and insert the USB memory stick into the slot. The USB memory stick should be formatted to FAT32 with firmware loaded (without the autoupd.ate file)



**2.** Switch on the oven and tap the top-right hand corner.

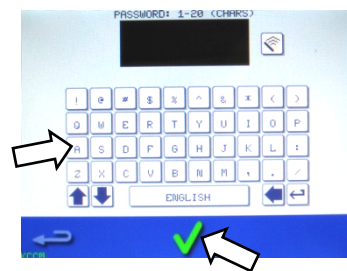

**3.** Enter the MANAGER password and select the green check mark.



**4.** Select the USB symbol from the settings menu.

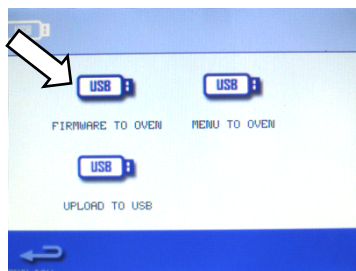

**5.** Select from the USB screen 'Firmware To Oven' (for QTS and SRB updates).

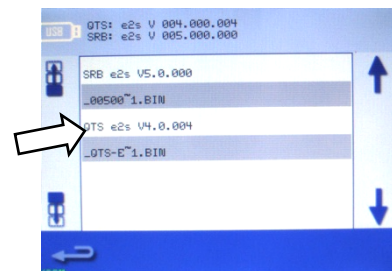

**6.** Install updates by selecting the correct files. If loading all firmware, updates should be installed in this order:  
 1. QTS update – see below for instructions  
 2. SRB update – see below for instructions  
 3. APP icons – see below for instructions

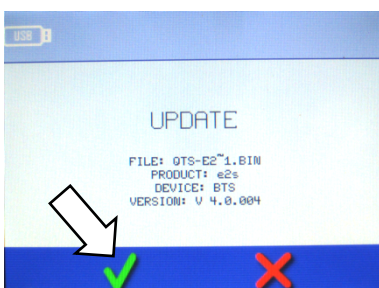

**7.** The update screen will display the file version and product. Select the green check mark to confirm the installation.

**■ QTS firmware update**

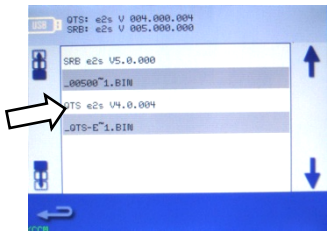

1. Select the 'QTS' file with the correct file version number.

**Note: A tinted band over a file name indicates the file is not valid for your oven.**

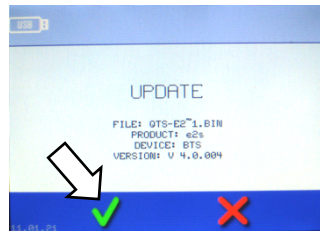

2. Check if the file information shown is correct before selecting OK.

If not select 'X' and locate the correct file.

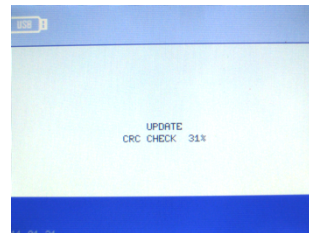

3. The file update progress is displayed. When the QTS download has been completed, the oven will reboot and display a flash screen as it updates (the cooling fan stops operating during the process). After 100% various screen displays appear as the software reboots.

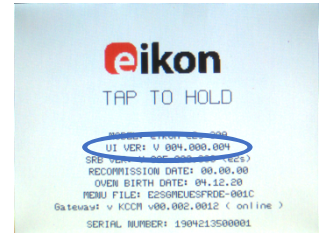

4. Once rebooted, check if the screen shows the correct QTS version (UI Ver:).

If not, repeat the process using the correct file.

5. Remove the USB memory stick and keep it in a safe place.

**■ SRB firmware update**

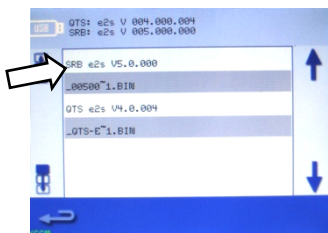

1. When you select firmware, the current QTS (Quick Touch Screen) and SRB (Smart Relay Board) firmware versions are displayed at the top left of the screen. Select the 'SRB' file with the correct file version number.

**Note: A tinted band over a file name indicates the file is not valid for your oven.**

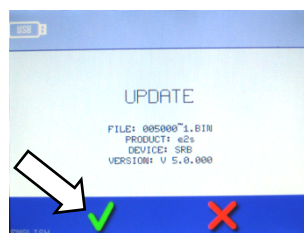

2. Check if the file information shown is correct before selecting OK.

If not select 'X' and locate the correct file.

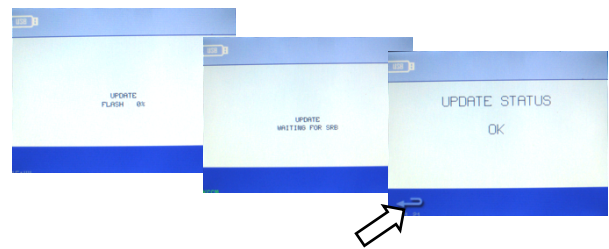

3. The SRB file is checked and the download progress from the USB is displayed followed by the update status and confirmation screens. Note: Wait until all files have been loaded. Do not touch the oven until the end of the downloading process.

4. When the download process is complete press the return (backspace) arrow to now update QTS file.



**APPS (icons) update**

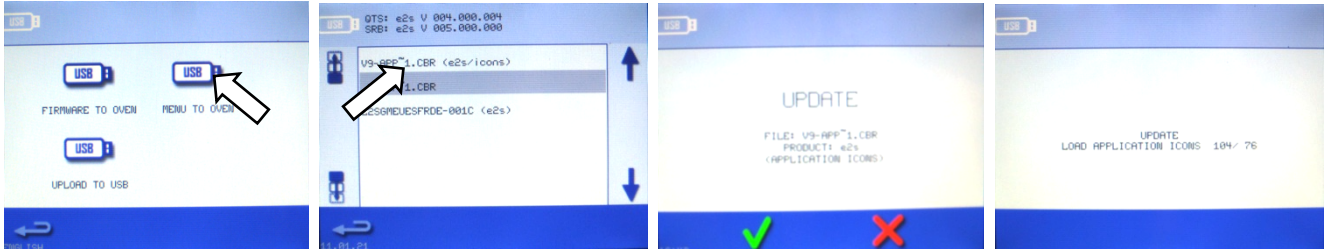

1. Select from the USB screen "Menu to oven"

2. Select the .CBR file (e2s/icons)  
**Note: A tinted band over a file name indicates the file is not valid for your oven.**

3. Check if the file information shown is correct before selecting OK.  
 If not select 'X' and locate the correct file.

4. The file update progress is displayed. When the application icons file download has been completed, the oven will reboot and display a flash screen as it updates (the cooling fan stops operating during the process). After 100% various screen displays appear as the software



5. On completion the start up screen is displayed showing the firmware versions and menu file before moving to the pre heat temperature screen

## 5 Service information

### 5.1 Service procedure

#### ■ Servicing procedure: overview

1. Disconnect/isolate the appliance from the power supply.
2. Check the appliance is correctly installed as described in the eikon® e2s Installation and User manual.
3. Visually check the cleanliness/condition of the power supply/cable, casing, cavity and door of the appliance for signs of wear, damage, distortion etc. If required, refer to the "Replacing components" section of this manual (section 6).
4. Complete an "Earth/Insulation test" (see section 5.6 of this manual) on the appliance before switching on.
5. Check the display for error messages. If an error is shown, refer to the "Fault Finding" within section 5.3 of this manual.
6. If a firmware update is required, follow the instructions under "Firmware updates" within section 4.5 of this manual before continuing with the service procedure.

#### ■ Touchscreen calibration

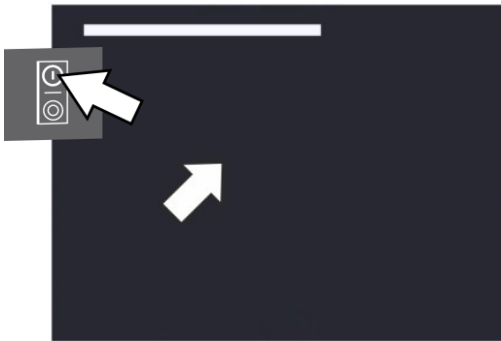

1. Apply continuous light pressure to the screen while switching the appliance on. Continue to hold until the progress bar has completed.

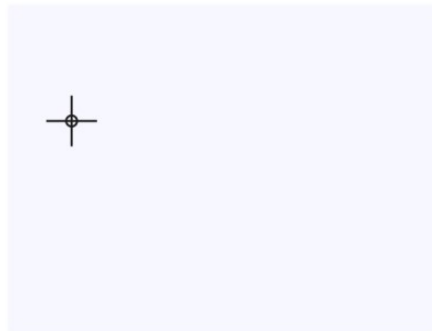

2. Using a non-abrasive pointer, such as a ball point pen, accurately press the centre of each crosshair displayed on the screen (ensure you are at eye level with the screen).

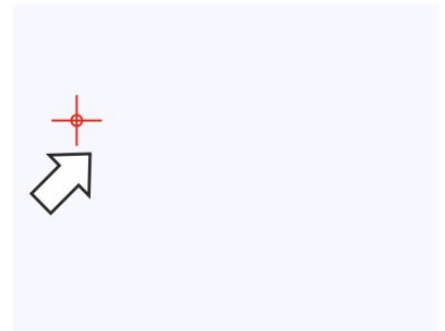

3. If the crosshair turns red you missed the centre of the crosshair and the calibration procedure will start again.

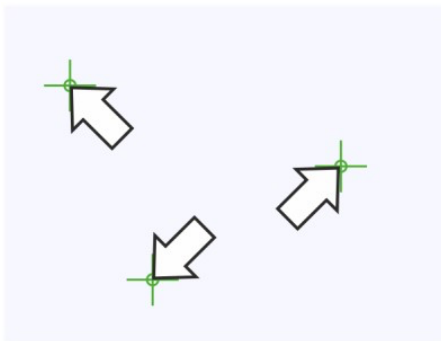

4. If the blue crosshairs turn green three times consecutively the calibration process is completed successfully.

Successful procedure = 3 black crosshairs that appear in differing locations, followed by 3 blue crosshairs that turn green.



5. Once calibrated the screen will display information about the appliance.

## ■ Enter service mode

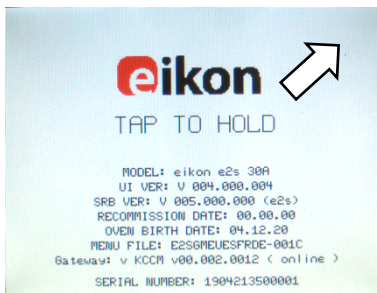

**1.** On start up, tap the top right of the splash screen to bypass preheat of the cavity.

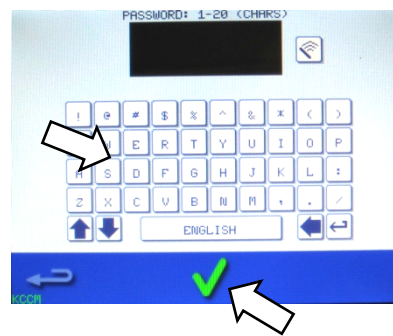

**2.** Enter the authorised user password, for example, "MANAGER" on the keypad. Select OK (green tick) to display the 'Settings' menu.



**3.** Select the spanner symbol.

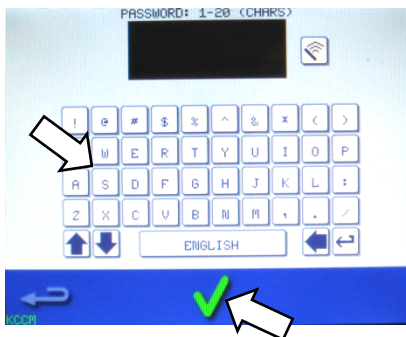

**4.** Enter the service password. For example; 'SERVICE' on the keypad. Select OK (green tick) to display service tabs.

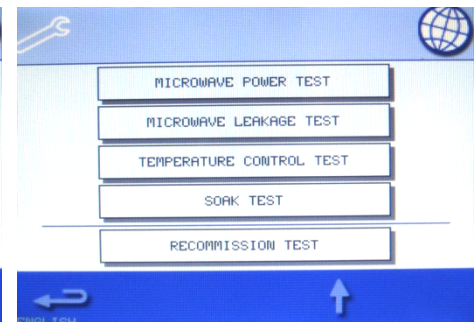
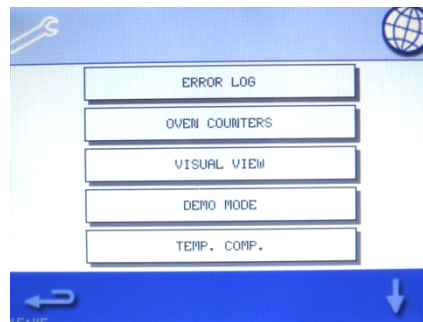

**5.** Select the relevant tab to display the error log, service information and test options.

## ■ Functions of the service mode

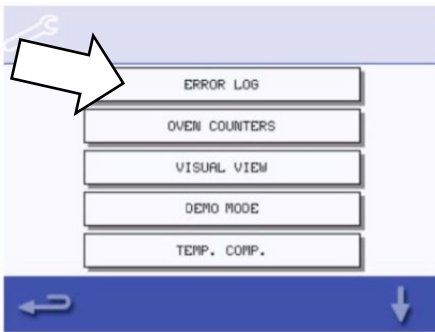

**1.** Check the "Error log" for details of any logged appliance errors. (Log also includes non-error events).

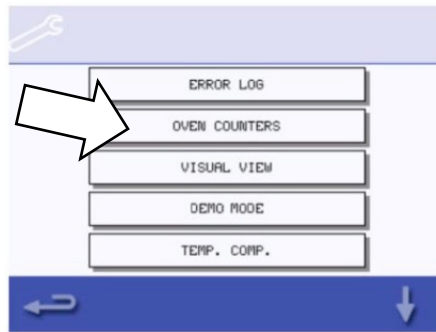

**2.** Check the "Oven counters" to find the usage of components and the controls area temperature within the cabinet.

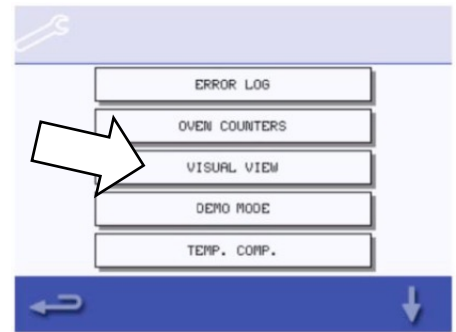

**3.** Check the operational performance of the main components using "Visual view".

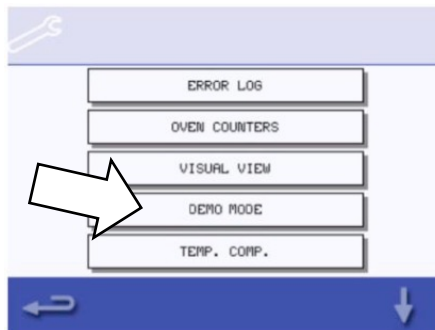

**4.** Check the "Demo Mode" to switch between normal operation and demonstration only operation.

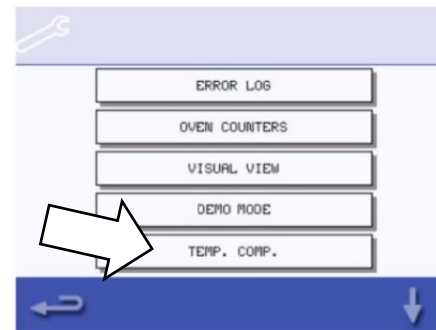

**5.** Check the "Temp. Comp." to enter the oven cavity temperature calibration mode.

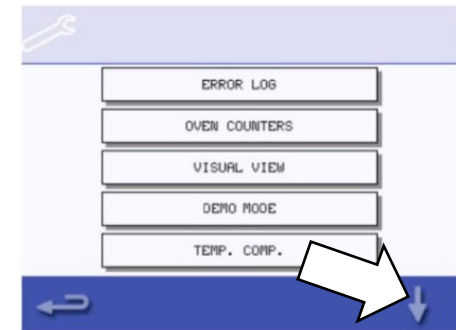

**6.** Use the 'down' arrow to access more options.

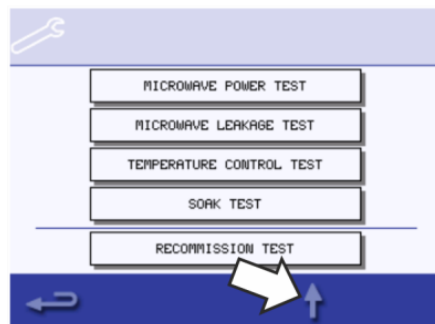

**7.** Check to perform the tests of your microwave combination oven as described in the "Testing selected components", section 5.6 of this manual. If required, refer to the "Replacing components" with section 6 for any repairs needed before continuing with the tests. Use the up arrow to return to the previous screen.

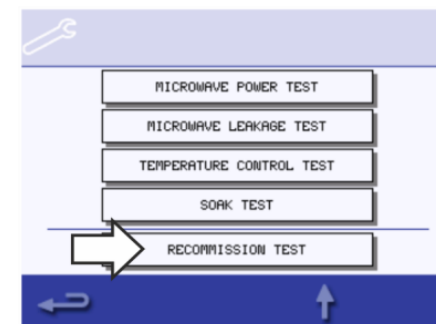

**8.** Follow the procedures under "Recommissioning test", section 5.7 before commissioning your appliance for use. These tests should be completed after all repair and maintenance procedures

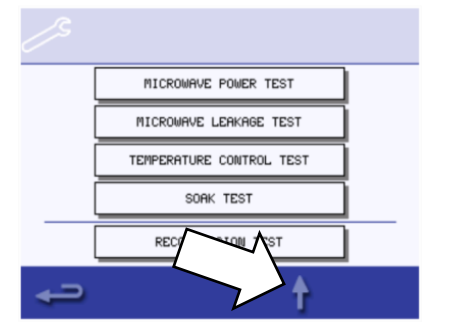

**9.** Use the 'up' arrow to access previous options.



**10.** The return (backspace) arrow will exit the service screens.

## 5.2 Errors and diagnostics

### Error messages



1. A description of the type of error is shown. Check for a number following 'ERROR:' and refer to the error codes ("Fault finding" within section 5.3 of this manual) for more details. The serial number of the oven, model, UI (QTS) version and SRB version information are also displayed below.

2. Clear the error message by switching the oven Off and then back On, or by power cycling the mains power supply to the oven.

See section 5.3 for error code list.

### Copying error messages



1. Enter settings menu and select the USB symbol. The USB screen appears.

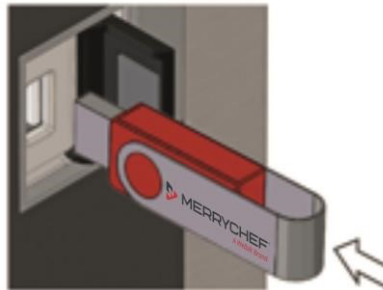

2. Open the cover of the USB port and insert the USB memory stick into the slot.

3. Select 'Upload To USB' on the USB screen.

NOTE:  
The USB memory stick may take several seconds to load before the screen will respond.

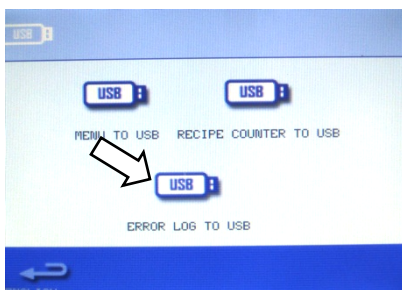

4. Select 'Error log to USB' on the following screen change pic to show correct labels.

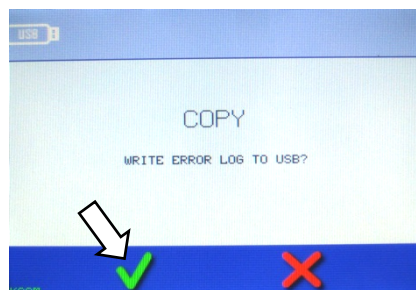

5. Select the green check mark to copy the error log to the USB memory stick. The update (copy download) progress is shown followed by the completion screen "update status OK".

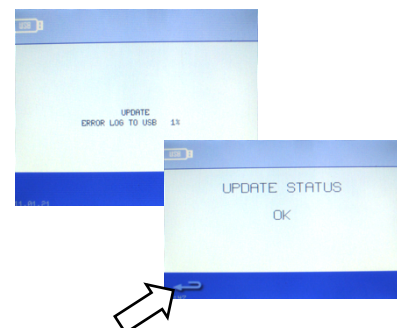

6. Select backspace 3 times when complete to return to the main menu.

7. Remove the USB memory stick.

**Error log**

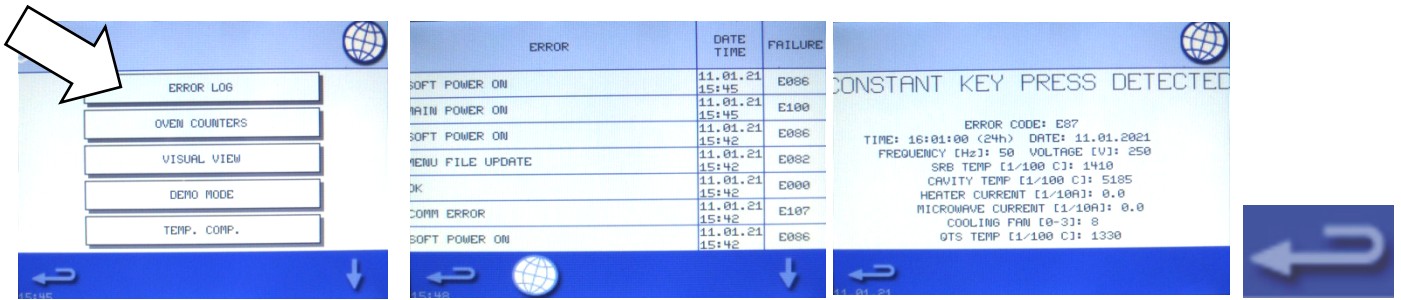

1. Enter service mode and select 'Error log' to display a listing of oven component errors &
2. Scroll down the list (if necessary) and select an error from the list to display individual records.
3. Error details include: component description, error caused, date and time of the error with details of failure and range.
4. Select backspace to return to the list, again to return to the service menu.

Further details can be read by copying the error log to a USB and opening the file on a computer (.csv file).

The saved errorxxx.csv file header includes;

- Oven Type
- Serial Number
- SRB Firmware Version
- QTS Firmware Version
- Oven Birth Date
- Date
- Filter Cycles
- Door Cycles
- Oven Power On Time
- Left Magnetron On Time
- Right Magnetron On Time
- Heater On Time

The error log includes;

- Error Time
- Error Code
- Error Description
- QTS Temperature
- SRB Temperature
- Thermocouple Temperature
- Calculated Cavity Temperature
- Preheat Temperature Setting
- Supply Voltage
- Supply Frequency
- Heater Current Draw
- Microwave Current Draw
- Heater Power Percentage
- Cooling Fan Speed (code)
- Convection Fan Speed Control Voltage
- Microwave Power Percentage
- Convection Fan Speed Percentage
- Cooking Stage Status, Time and Time Remaining

Downloading a copy of the 'Menu' file and 'Recipe Counter' file may provide further information for in-depth fault diagnosis.

**Cooking profile counter**

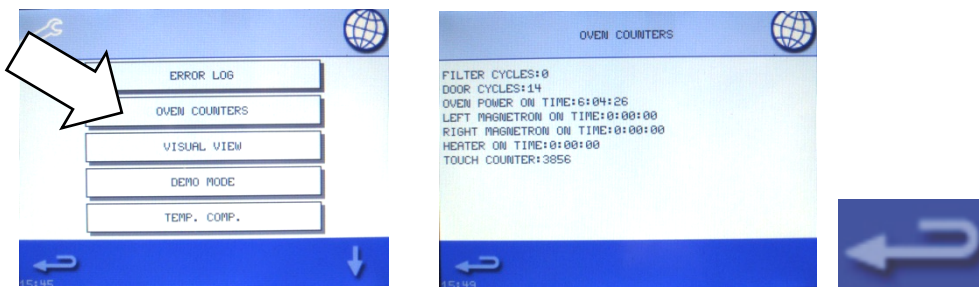

1. Select 'Oven counters' to display the filter & door cycles and oven component usage.
2. Details include the number of filter cycles, door cycles, total oven on time, magnetron and heater element power on times and screen touches.
4. Select backspace to return to the list, again to return to the service menu.

**Visual view**

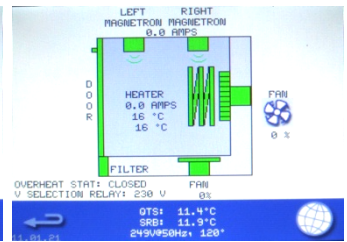
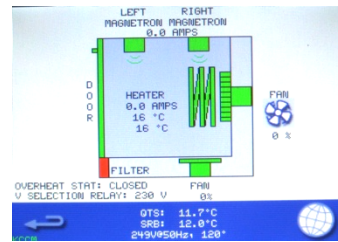
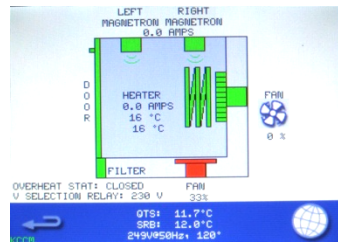
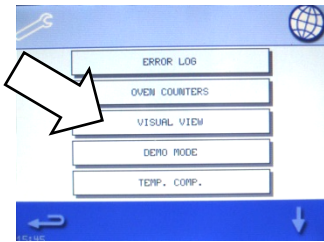

1. Select 'visual view' to check the main components of the appliance. If an error is present the selection is greyed out and cannot be selected without first turning the oven off and back on again.

2. Select a component symbol to switch on (red). Select again to increase the level (remains red) or turn off (green). With the exception of the magnetron(s), all the component tests will work with the door open or closed.

3. Remove the air filter at the front of the oven. The colour of the air filter symbol on the display should change from green to red indicating that the microswitch circuit for the air filter is operating correctly. Replace the air filter and the colour should change

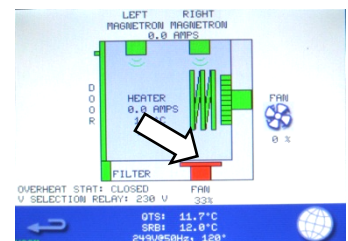
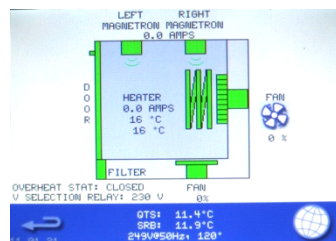
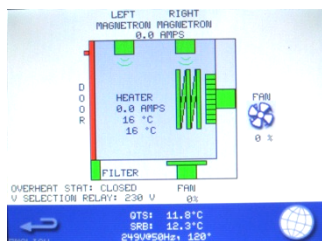

4. Open the oven door. Check the colour of the door symbol changes from green to red on the display to check the door microswitch / interlock circuit is operating. Place door spacers onto the oven door (refer to "Adjusting the door microswitches / interlocks" in the "Replacing components" within section 6.11 for details), to confirm the door switches are adjusted correctly. Close the door and check the colour of the door symbol on the display.

5. Select the cooling fan and check if it is operating correctly. Repeated presses will increase the fan speed, noticed by an increase in the fan noise volume and air flow through the filter (off / 30%, 50%, 85% / 100% / off).

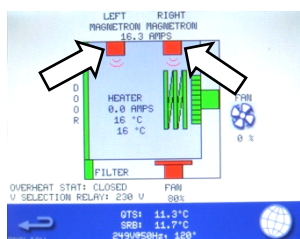
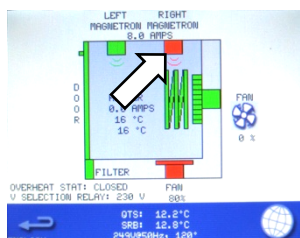

6. Place a microwave safe container of water into the left cavity and close the oven door. Select a magnetron to test operation and display the current draw at maximum output. This will time-out after 30 seconds (the cooling fan will automatically run at 80% during the test).

**Individual magnetron test:**

If during the magnetron test the displayed current is 0 A and the E101 error occurs after 12 seconds, then the failure can be found in the 230V circuit. Refer to the schematics to find the fault for repair (SRB, connections, HV primary winding).

If during the magnetron test a low current draw is seen (around 3A) and the E101 error occurs after 12 seconds, then the failure can be found in the high voltage circuit. Isolate the power supply and test the high voltage components (HV transformer, diode, capacitor, magnetron and connections) to find the fault for repair. Never measure in the high voltage circuit live. See "Replacing components" within section 6 of this manual.

**Dual magnetron model (2000W e2s variant):**

Test the magnetrons individually and together.

Selecting the magnetrons again at any point will turn them off.

Using heat proof gloves, remove the container and close the oven door.

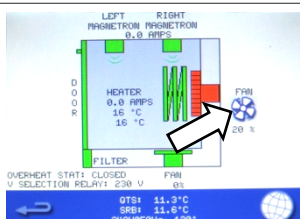

7. Select the convection fan and check if it is operating correctly. When increasing the fan power gradually, in 10% increments, to 100% the fan noise should become louder.

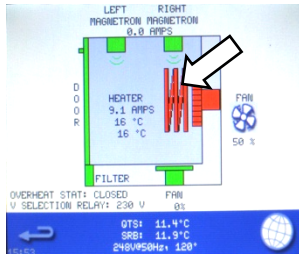

8. Select the heater, it increases to a maximum cavity temperature of 250°C and then continually cycles, maintaining this temperature. Selecting the heater again will turn it off. The convection fan automatically runs at 50% by default (the fan speed can be manually altered up to 100%).

Check the cavity temperatures and heater element current draw are correct. The displayed current should be between 9A and 10A @230V but is dependent on the mains supply voltage. The current draw will start to reduce between 225°C & 250°C. Both displayed temperatures (thermocouple reading & calculated cavity temperature) should be similar.

9. Further diagnostic information can be found below the oven picture;

Safety circuit condition, i.e "Overheat Stat: Closed"

Voltage selection relay condition, e.g. 230 V

QTS board temperature

SRB board temperature

Mains supply voltage and frequency (as read on the SRB)

and scrolling current language selection, time & date and KCCM if installed (**KCCM** = KitchenConnect offline /

**KCCM** = KitchenConnect online)



## 5.3 Fault finding

### Hardware control components

#### Operations communication:

1. The oven has two main controlling parts, being the QTS assembly (keyboard, screen, logic) and the SRB (Smart Relay Board to switch and monitor the required operation).
2. The QTS is the master of the oven and instructs the SRB what to do, in turn the SRB communicates information on the operation back to the QTS.
3. The QTS and SRB have their own Personality Module (PM) fitted with the respective software to be able to communicate and work with each other.
4. The power provision to the QTS and the communication between QTS and SRB is enabled via ONE cable with RJ45 connectors fitted.

#### Start-up sequence

With the oven switch in the OFF position and the mains power ON, the QTS & SRB boards boot up. Boot up information will be displayed on the screen, which will then go blank awaiting a switch on. When the oven switch is turned ON the splash screen briefly displays oven information, if required tap the screen ("tap to hold") to keep the data visible. After completing a successful logic test, the safety relays are energised and the cabinet cooling fan, convection fan and stirrer(s) are activated. The oven then preheats or displays a preheat temperature choice. Once preheated the oven displays the main menu if in "Full service mode" or a recipe selection if in "Quick service mode".

#### Shutting down sequence

When the oven switch is turned OFF the screen displays 'Shutting down' and the microwave and heater safety relays de-energise. The cooling fan and convection fan operate until the cabinet temperature has been sufficiently reduced to a cavity temperature of 50°C (122°F). The QTS & SRB boards remain active whilst a mains power supply is present.

### Exchanging data via USB interface

Loading menus/firmware from a USB memory stick and downloading the menu/recipe counters/error log to a USB memory stick is covered in sections 4.4 & 4.5 within this service & repair manual.



## ■ Error codes & fault finding tips

Please adhere to all best safety practices by Merrychef and ensure the High Voltage circuitry has been successfully discharged before attempting any works on or around the Merrychef unit while the panels are off. Further information can be found at: [merrycheftechnical.com](http://merrycheftechnical.com)

If in doubt, please contact your Merrychef/Welbilt technical support team for support.

Note: The error log can be accessed directly during an error condition, without switching the oven off and on, by selecting the settings icon.

Error	Problem	Solution
<b>E101: MAGNETRON FAILED</b>  (magnetron failed on request)	The oven asked for microwave power but the current draw in the primary circuit was less than 5A on either or both magnetrons.  (the ampere values during microwave operation help determine where the fault is located)	Use Visual View in the service mode for analysing/testing the individual magnetrons. One magnetron at a time. Zero amps (0A) indicates a fault in the primary circuit (wiring from the SRB board to the and including the HV Transformer). A current draw lower than 5A indicates a fault in the secondary circuit (wiring and components after and including the HV transformer). Isolate the power supply and test the high voltage components (HV transformer(s), diode(s), capacitor(s), magnetron(s) and connections) to find the fault for repair. <p style="text-align: center;"><b>DO NOT SUSPECT IT'S THE MAGNETRON AT FAULT FIRST</b></p> Go to the error logs, is the mains voltage normal at time of fault? (note that the current draw detailed in the error log is the sum of all magnetrons fitted, test one at a time) Voltage too low, below -10% of nominal voltage; There may not be enough voltage to start the magnetron. If the above did not resolve the issue, check all the LV connections are tightly fitted, from the incoming power supply through the Filter, Fuse F2, Door Switches, SRB board and from the SRB board to the HV transformer(s). The connections on the HV side from the HV Transformer through the Capacitor(s), HV Diode(s) and Magnetron(s). Also check the HV Transformer(s) is firmly bolted down (the body of the transformer forms part of the HV circuit). There are many connections so each of them is important to be tightly connected and checked. Most important connection: "the loose one" (ensure all connections are solid and in good working condition).
<b>E102: HEATER FAILED</b>  (Heater on without request)	A current draw >1A detected on the SRB when the heating element is switched off. Typically happens when the output Triac has short circuited	The heating element is activated even though the controller hasn't asked for heating. Change the SRB board and check carefully all related circuitry including loose wiring and connections. Ensure the oven cabinet is clean and there are no leaks from the cavity.
<b>E103: AMBIENT OVERHEAT</b>	The ambient temperature around either the QTS & SRB boards is >70°C, insufficient cooling of the components. Frequently observed when the customer	The Air Filter must be cleaned on a daily basis. Check that the oven is not installed near to a heat source enabling the cooling fan to draw in hot or grease laden air via the Front Filter. Check that the Cooling Fan is operating correctly: Inspect and ensure that the fan is running freely and that the speed is correct. If the speed is very slow and running freely replace the cooling fan capacitor. The wiring of the capacitor is sensitive, ensure you connect the wiring like for like, otherwise the fan may rotate in the opposite direction. The fan should run counter clockwise (looking down from above) drawing air from the centre of the fan into the component interior of the oven, creating a positive cabinet air pressure. That's why the panels

Error	Problem	Solution
	forgets to clean the front filter.	<p>should all be nicely fitting as it is part of the design to ensure proper air flow and cooling.</p> <p>The error will remain until the board temperatures drop below 50°C.</p> <p>Check the board temperatures in the error log and in visual view (in service mode). QTS temperatures significantly higher than the SRB can indicate a poor door seal.</p>
<p><b>E104: OVERHEAT STATS RELEASED</b></p> <p>(Cavity overheat thermostat / Magnetron overheat thermostat(s) / Convection Fan internal protection ~ IP)</p> <p>(also see E115)</p>	<p>The safety thermostat circuit (12vdc) is open circuit - SRB connections 18c to X18e.</p> <p>Frequently observed when the customer forgets to clean the front filter.</p>	<p>Switch the oven off and back on. If the error comes back on, before the pre-heat screen (preventing the oven from operating), the safety circuit is still open, and the Heater &amp; Microwave SRB safety relays will be de-energised to prevent operation.</p> <p>Switch the oven off and remove oven from mains supply for 20 mins. Reconnect the mains supply and switch the oven back on. If the oven still shows the E104 fault the issue is likely to be the cavity overheat thermostat is open circuit. If fault clears, the fault is likely to be either with the magnetron(s) or convection fan motor overheating.</p> <p>Check all safety trip circuit wiring and connections.</p> <p>Check the continuity of each switch individually.</p> <p>The magnetron overheat thermostat(s) and convection fan motor internal protection should automatically reset once they have cooled down. The cavity overheat thermostat requires a manual reset by removing the 5.5mm cover bolt from the back panel (next to the rear vent) and depressing the reset button.</p> <p>The magnetron and convection fan overheats are typically caused by a lack of cooling. Check the board temperatures in the error log to determine the cabinet air temperature at the time of the failure.</p> <p>Check the magnetron cooling fins (heat sink) are clean and free from dust, debris and grease build up, clean as required.</p> <p>Sufficient cooling is required, please ensure all panels are fitted correctly and do not have any cooling leakages from around the panel work.</p> <p>Check the air curtain at the front of the unit for sufficient cooling.</p> <p>The cavity overheat thermostat typically trips if the mains power is disconnected at the end of service without allowing the cavity to sufficiently cool down first. Noticed by the E104 error occurring at the beginning of service the next day.</p> <p>If the magnetron is active when any of overheat thermostats open (trip), the E115 error will be generated (E117 on older firmware revisions)</p> <p><b>NOTE: If the magnetrons are tested without the ovens panels in place, which is NOT RECOMMENDED, the lack of air flow will cause the magnetron(s) to overheat and cause the magnetron overheat thermostat(s) to open circuit. The panels are designed to guide the cooling air sufficiently through the cooling fins in a forced airflow manner.</b></p>
<p><b>E106: CAVITY OVERHEATED</b></p> <p>Cavity too hot</p>	<p>A software generated error in relation to the settings; cavity thermocouple reading 25°C above the set point once reached</p>	<p>The convection fan could have stalled. (stopped working)</p> <p>Check the speed controller/fan speeds up and works properly.</p> <p>Check the fan rotation (Impinger airflow speed).</p> <p>Ensure the convection fan can freely turn without obstructions.</p> <p>Ensure the thermocouple is fitted correctly to the SRB board connector with no loose connections.</p> <p>Check for possible signs of a product fire in the cavity</p>
<p><b>E107: COMM ERROR</b></p> <p>Communication error between the QTS &amp; SRB</p>	<p>E107 observed in the error log</p>	<p>Ensure cable connections are secure, especially the J45 connected cable between the SRB and the QTS board.</p> <p>Replace the J45 Communication cable between the QTS and SRB as required.</p> <p>E107 can be recorded in a non-fault condition during an initial boot up when the power supply is switched on to the oven and during firmware updates. This is usual and will be followed by E000 to confirm the communication has been established.</p>

Error	Problem	Solution
<b>E108: QTS PM FAILED</b>	The PM code is incorrect for the QTS	<p>Check the PM chip is correctly in place on the QTS board.</p> <p>The QTS has a dedicated part number on the chip which is unique for each eikon model.</p> <p>Ensure the correct PM chip has been inserted to the QTS, an easy mistake to make when both boards are replaced, don't forget to transfer the PM from the old QTS to the new QTS.</p> <p>Loading of new up to date firmware is a must.</p>
<b>E109: SRB PM FAILED</b>	The PM code is incorrect for the SRB	<p>Check the PM chip is correctly in place on the SRB.</p> <p>The SRB has a dedicated part number on the chip, which is unique for each eikon model.</p> <p>Ensure the correct PM chip has been inserted to the SRB, an easy mistake to make when both boards are replaced, don't forget to transfer the PM from the old SRB to the new SRB if replaced.</p> <p>Loading of new up to date firmware is a must.</p>
<b>E110: SRB VERSION CONFLICT</b>  Incompatible SRB Version	Incompatible firmware versions on the SRB / QTS boards. Can occur on replacement of either boards and during loading of firmware.	<p>Download the up to date firmware from <b>merrycheftechnical.com</b></p> <p>Load the latest firmware on to the oven using the autoup.ate file. Do not switch off or interrupt until the oven starts to heat up, or the pre-heat selection screen is displayed.</p> <p>In the event of a continued issue, replace both personality modules (PM's) and reload the firmware.</p> <p>Ensure there are no microwave leaks present around the control boards.</p>
<b>E111: CAVITY SENSOR</b>	Cavity thermocouple damaged or unplugged. No temperature rise registered for 10 minutes during heating	<p>Check that the thermocouple is correctly fitted and secure on to the SRB</p> <p>If the thermocouple generates erratic values, or is more than 25°C out of range, it will need to be replaced if the connection is in good condition and intact.</p> <p>If the fault reoccurs after replacing the thermocouple, replace the SRB.</p> <p>Check the error log. If the cavity temp reads 32767 (327.67°C) the sensor was open circuit or not connected. A closed circuit will register the SRB board temperature and will not generate the E111 error unless the oven has been heating for 10 minutes.</p>
<b>E112: SRB BOARD TEMP SENSOR</b>	Ambient temperature sensor failure on the SRB	SRB failure. Replace SRB (Don't forget to remove the old PM chip and insert in to the new SRB). Download the up to date firmware from <b>merrycheftechnical.com</b> and load on to the oven
<b>E113: MAGNETRON ON WITHOUT REQUEST</b>	A current draw >1A detected on the SRB when the microwave circuit is switched off.	SRB failure. Replace SRB (Don't forget to remove the old PM chip and insert in to the new SRB). Download the up to date firmware from <b>merrycheftechnical.com</b> and load on to the oven
<b>E115: MAGNETRON OVERHEAT</b>  Magnetron overheat thermostat tripped	The safety thermostat circuit (12vdc) has opened during a cook cycle with microwave.	<p>See E104 for descriptions and diagnoses.</p> <p>E117 on older firmware versions. Download the up to date firmware from <b>merrycheftechnical.com</b> and load on to the oven</p> <p>This warning error requests operator to 'clean and replace the air filter located below the door'. The warning will clear when this action is taken</p>
<b>E116: HEATER FAILED</b>	The oven asked for heating, but the current	<p>Check all the connections are in good condition and secure, from the incoming power supply through the Filter, Fuse F1, SRB board and the heating element.</p> <p>The heater element rarely fails, checking all of the connections first is imperative.</p>

Error	Problem	Solution
(Heater off on request)	draw was <1A on the heater circuit.	Ensure you counter hold the rear bolt of the element connections before tightening the front nut on the element. Lastly replace SRB
<b>E117: see E115 MAGNETRON OVERHEAT</b>	Old firmware. The safety thermostat circuit (12vdc) has opened for >1 second during a cook cycle.	Download the up to date firmware from <b>merrycheftechnical.com</b> and load on to the oven

#### Warning Error Codes generated during operations:

Error	Problem	Solution
<b>E079: TOUCH PREWARNING RELEASE</b>  (Constant key press)	Pressure registered for >5 seconds, but <15 seconds on QTS screen	Check touch screen overlay, see E087
<b>E080: TOUCH PREWARNING</b>  (Constant key press)	Pressure registered for >5 seconds on QTS screen	Check touch screen overlay, see E087
<b>E083: SRB VERSION</b>	Incompatible SRB version	Replace SRB, check part numbers.
<b>E084: INVALID DATE</b>	Invalid date at start up	Set correct date and time
<b>E087: CONSTANT KEY PRESS DETECTED</b>	Pressure registered for >15 seconds on QTS screen. Oven will stop working.	Ensure the firmware is up to date with the most recent update which can be found at <a href="http://www.merrycheftechnical.com">www.merrycheftechnical.com</a> Ensure there is no debris between the QTS screen and the overlay film. Ensure the QTS assembly is installed correctly Replace the overlay and clean the glass of the touchscreen, execute a screen calibration. Lastly, replace the QTS.
<b>E088: SUPPLY VOLTAGE ERROR</b>	Mains supply voltage is $\pm 10\%$ from the nominal range across all models (200V – 240V), i.e., <180VAC or >264VAC mains supply	Check mains supply voltage and compare with displayed voltage in visual view. If similar the fault lies within the kitchen mains supply. If significantly different, check all connections from the mains supply to the SRB. If correct, replace SRB.
<b>E099: FILTER OVERRIDE</b>	Operator selected continue when filter was removed (filter microswitch was open circuit)	Check filter magnets, filter microswitch & connections

Error	Problem	Solution
<b>E105: FREQUENCY SUPPLY</b>	Mains supply frequency is $\pm 2\%$ from nominal	<p>Mains supply frequency is <math>\pm 2\%</math> from nominal or interference e.g., an internal microwave leak? Most of the issues found here are related to an unstable power supply of the building, i.e., Generators. It is recommended to check the supply and/or analyse the error log on a computer</p> <p>Ensure there are no microwave leaks by inspecting the unit with a suitable microwave leak detector</p> <p>Ensure there is a bowl (suitable for microwaves) of water (250ml cold) and activate a microwave leak test in the service screen mode. Check around the door seals front and rear of the unit. If microwave leaks are observed (if a level of <math>5\text{mW}/\text{cm}^2</math> or higher is observed the oven must not be used until repaired) unplug from the mains and investigate. Note: there should be no microwave leakage and corrections should be made if any leakage is detected above <math>0.5\text{mW}/\text{cm}^2</math>.</p> <p>Check for damaged cavity thermocouple</p>

**Information Error Codes:**

Error	Problem	Solution
<b>E000: OK</b>	Communications have been established between the SRB & QTS boards	<p>Solution not required if event recorded after mains power has been supplied to the oven (E100) or during successful firmware updates.</p> <p>Check all QTS &amp; SRNB connections.</p> <p>Check condition and connections on communication cable, SRB X11 to QTS X4.</p>
<b>E081: UNKNOWN ERROR</b>	Firmware updated, check sum error	Solution not required
<b>E082: MENU FILE UPDATE</b>	'Event' not an error. Menu or App (.crb) files have been updated	Solution not required
<b>E086: SOFT POWER ON</b>	'Event' not necessarily an error. SRB received ELV voltage signal from the on/off switch or reboot during firmware update(s)	<p>Solution not required if events correspond with normal operation.</p> <p>Check connections and on/off switch if event is recorded multiple times in quick succession</p>
<b>E098: INCOMPLETE CLEANING</b>	Cool down cleaning process not completed	<p>Event recording no longer in use.</p> <p>Download the up to date firmware from <a href="http://merrycheftechnical.com">merrycheftechnical.com</a> and load on to the oven</p>
<b>E100: MAINS POWER ON</b>	'Event' not necessarily an error. SRB supplied with 24V from transformer once mains power is switched on.	Solution not required if events correspond with normal operation.

**Error Codes generated during recommission test:**

<b>E089:</b> Recommission Fail Cooling Fan	User input 'X' (to confirm not working)
<b>E090:</b> Recommission Fail Convection Fan	User input 'X' (to confirm not working)
<b>E091:</b> Recommission Fail Turntable	No user input registered (not applicable to e2s)
<b>E116:</b> Heater Failed	(E092) <1A current draw recorded, see E116 for further details
<b>E101:</b> Magnetron Failed	(E093) <5A current draw recorded on either magnetron, see E101 for further details
<b>E094:</b> Recommission Fail Filter Install	No user action registered within 10 seconds. Filter microswitch signal remained open circuit, check filter microswitch & connections
<b>E095:</b> Recommission Fail Filter Removal	No user action registered within 10 seconds. Filter microswitch signal remained closed circuit, check filter microswitch & connections
<b>E096:</b> Recommission Fail Door Close	No user action registered within 10 seconds. Door switch circuit remained open circuit, check door switches & connections
<b>E097:</b> Recommission Fail Door Open	No user action registered within 10 seconds. Door switch circuit remained closed circuit, check door switches & connections

**Additional Errors / Faults**

<b>Error</b>	<b>Problem</b>	<b>Solution</b>
Door open	Door open continuously displayed when the door is closed	Check F2 fuse, if blown replace door switches Check door switches are adjusted correctly Check oven door hinges are fitted / working correctly Check all wiring and connections Check L2 is present on twin phase ovens
Continuous key press	Oven not operational, displaying 'constant key press message	See E087
Shutting down	Oven shuts down randomly during operation	Check on/off switch wiring and connections Replace on/off switch.
Cooking timer jumps suddenly back to zero	Oven finishes cook cycle prematurely	Experiencing when microwave is on, check for internal microwave leakage with a suitable microwave leak detector (inspect magnetron/waveguide at first). Check if magnetron is tightly connected, Seal off the joint/junction path between the two halves of the waveguide parts. Move all wires as far as possible away from each other (High Voltage versus the others).
Update Status Read from USB Fail	Failure to download menu	Power cycle oven and reattempt to download menu file to the oven. Reload menu on to USB memory and attempt to download menu file to the oven. Reload menu on a different USB memory and attempt to download menu file on to the oven
No USB Memory detected	Unable to read inserted USB Memory	Incorrectly formatted USB Memory. Re-format and re-load files. Slow key, allow further time for oven to read USB Memory.
Touch screen nonresponsive	Oven cannot be used	Check QTS X13 connection & cable. Replace QTS
Touch screen only responsive in some areas	Oven cannot be used successfully	Replace QTS
Touch screen displaying multiple coloured lines	Oven cannot be used	Check QTS X9 connection & cable. Replace QTS.
Touch screen blank (lit)	Oven cannot be used	In calibration mode, look for small cross and calibrate. Replace QTS.
Touch screen blank (dark)	Oven cannot be used	Check on/off switch. Check all QTS & SRB connections.

## 5.4 Safe working when testing components

### ■ For your safety when testing oven components

Before starting oven tests, familiarize yourself with the rules and hazard warnings in section 2 'For your safety', specifically section 2.14 'Safe working when testing components'.

## 5.5 Requirements

### ■ Equipment required for testing the appliance

HV Capacitor discharge tool	5.5 mm socket wrench
Portable Appliance Tester (P.A.T.)	Torque wrench
Digital Multi-Meter (D.M.M.)	1000 volt rated general hand tools
Proprietary voltage detector	1000-volt proof insulated rubber gloves
Electrical lock out tools & equipment	PPE
Megger / similar 500 V d. c. Insulation tester	
Microwave detection / leakage meter (calibrated)	
Temperature reader (calibrated)	
Microwave safe 600 ml glass beaker	
Microwave safe 2 litre container	

## 5.6 Testing selected components (casing mounted)

### ■ Technical advisory notice: PAT testing of Merrychef ovens

While testing with a Portable Appliance Tester (PAT) is not an automatic requirement for the Merrychef commercial combination microwave oven models, the following notice is to advise on this testing in addition to the following instructions as deemed necessary.

If the customer requires PAT testing of the Merrychef equipment we suggest this is limited to a) earth continuity and b) insulation resistance (measured at ~ 500 V DC). All Merrychef commercial combination microwave ovens are classified as CLASS 1 for the purpose of testing.

Should it still be deemed necessary by the customer to perform an Earth Leakage test, the following advice should be adhered to. Note that not all PATs are capable of just measuring the leakage or allow you to set a pass limit and therefore may not be appropriate for this test.

#### **WARNING**

##### **High leakage current**

Merrychef appliances are fitted with radio interference filters and inverter circuits which cause an increase in leakage current. The PAT may indicate an erroneous failure condition depending on its internal "pass"/"fail" settings. Please refer to the revised limits which apply to the specific Merrychef oven model.

Model	Model maximum limit applied with radio interference filter fitted
eikon® e2s	10 mA

#### **WARNING**

##### **Never touch the component under test while tests are being carried through.**

- Call a trained authorized Merrychef service agent if the oven under test still fails in order to check all earth connections and disconnect the radio interference filters before repeating the test if required.

## Earth/insulation test

Check that the following requirements have been met:

- The appliance has been disconnected from the power supply and protective measures have been taken to ensure the power cannot be switched on again.



**1.** Connect the mains lead from the appliance to a portable appliance tester.

**2.** Connect the earth from the portable appliance tester to the equipotential bonding point on the oven.

**3.** Place the portable appliance tester in an open area, such as the floor, away from any persons.

Perform a Class 1 test in accordance with tester instructions.

- A PASS indicates the oven earthing circuit is functioning correctly.
- If a FAIL is indicated (i.e., unit exceeds maximum limit), remove the casing of the appliance and check ALL earth connections. Then repeat the Class 1 test.

### **⚠ WARNING**

**Never operate an appliance that has failed this test as it could be potentially dangerous.**

## Service mode: tests menu

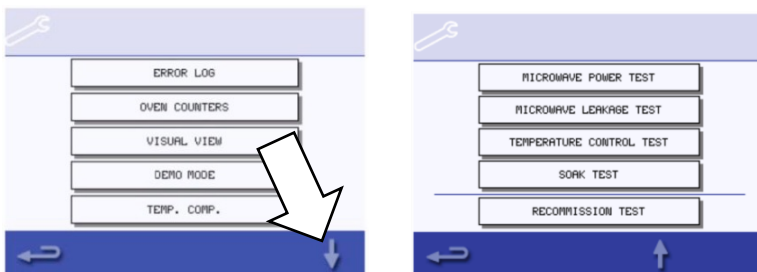

**1.** Enter service mode. For details see "Accessing the service information" section 5.1. Select the down arrow to display the individual tests for the appliance to

## Microwave power test: measuring the microwave power output of the magnetron(s)

Check that the following requirements have been met:

- The appliance is cool.

### **NOTE:**

The power output is established under IEC 705 standard method which is only workable in laboratory controlled conditions. The power output is also affected by line voltage under load, so this test is an approximation only.

- Ensure the cavity is close to ambient temperature
- Enter the service mode.
- Fill a microwave safe container (glass or plastic) with one litre (1.78 pints) of cool tap water, ideally at 20°C (68°F).
- Measure and record the water temperature in the container using a thermometer capable of reading  $\pm 0.1^\circ\text{C}$  increments.
- Place the container centrally into the cavity.



6. Select 'Microwave power test' from the service mode tests (microwave power 100% for 63 seconds, convection fan at 10%).

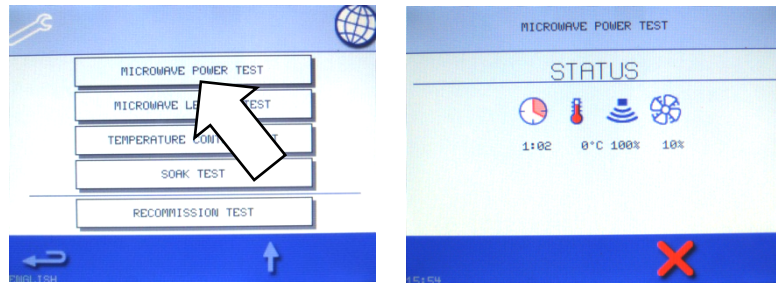

7. When the countdown has finished, remove the container from the cavity. Immediately stir with a plastic implement and measure the water temperature.

8. Calculate the temperature rise of the water (end temperature minus the start temperature). The temperature rise should be 14.3°C (25.7°F) ±10% for the 1000W (1 magnetron) variant. The temperature rise should be 28.5°C (51.4°F) ±10% for the 2000W (2 magnetrons) variant. If the temperature rise is outside these limits repeat test and/or check the microwave circuit and components. A low reading could be caused by the water container absorbing the energy, in which case an alternative container should be used.

Replace the faulty HV component if required (see High voltage components in section 5.8).

Note: Opening the door during the test will stop the test. Reselect the test to run again.

## ■ Microwave leakage test

Follow these instructions when measuring:

- Make sure that the survey meter you are using has been calibrated and is suitable for measuring frequencies of 2,450 MHz.
- Do not exceed meter full scale deflection. The leakage meter should initially be set to the highest scale, then adjusted down as necessary to ensure that low readings are measured on the most sensitive range.
- To prevent false readings, hold the probe on the grip provided and move at 2.5 cm/second.
- Always hold the probe at right angles to the oven and point of measurement, ensuring the probe sensor is reading 50 mm from the test area.
- The leakage should not exceed 5 mW/cm<sup>2</sup>.

1. Add 275 ml of cold water into a 600 ml microwave safe container.
2. Place the 600 ml container in the centre of the cavity and close the door.

3. Enter service mode on the screen and select 'Microwave leakage test' from the appliance tests (microwave power 100% for 30 seconds, convection fan at 10%).

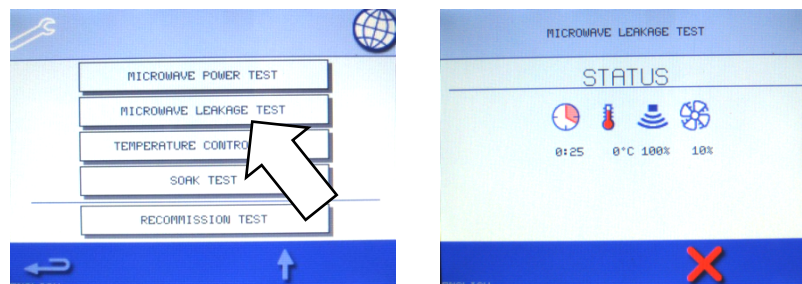

4. Set the leakage meter to the appropriate scale/range.

5. Move the survey meter probe across all casework joints and vent areas including those marked in yellow, shown opposite.

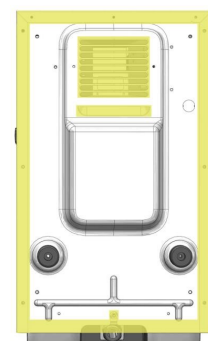

6. When the microwave leakage test stops after 30 seconds, change the water and re-select the test to continue.
7. Select the red 'X' on the display to stop the test at any time.
8. Readings must be below 5mW/cm<sup>2</sup>, ideally zero as there should be no microwave leakage and corrections should be made if any leakage is detected above 0.5mW/cm<sup>2</sup>.

**⚠ CAUTION:**

**If a level greater than 5mW/cm<sup>2</sup> is observed, don't use the appliance until repaired.**

9. Note any leakage that is observed in terms of the level and position on the appliance. Keep this information with the service documentation.

Note: Opening the door during the test will stop the test. Reselect the test to run again.

## ■ Temperature control test

When selected the oven will run on heat only, convection fan at 100%, for 30 minutes up to the maximum cavity temperature of 275°C.

Note: Opening the door during the test will stop the test. Reselect the test to run again

**This test only generally recommended for workshop activities.**

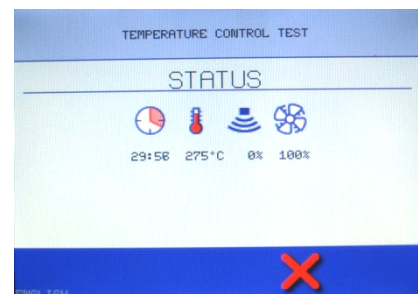

## ■ Soak test: checking the cavity integrity

1. Place a covered oven/microwave safe container with approx. 2 litres of water into the cavity.

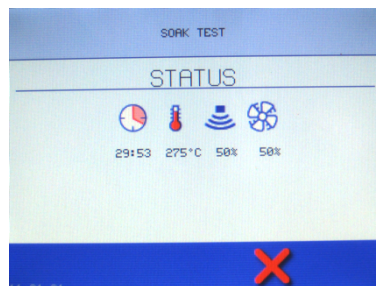
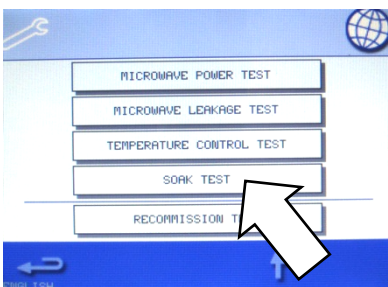

2. Close the appliance door and select 'Soak Test' from the service mode oven tests (275°C maximum oven temperature, 50% microwave power, 50% convection fan speed for 30 minutes).

3. Run the test (30 minutes), carefully checking the appliance casing, joints and door seal for signs of steam or water escaping from the cavity.
4. If necessary, rectify any leaks and repeat the test.
5. Safely remove the container of water from the cavity on completion.

Note: Opening the door during the test will stop the test. Reselect the test to run again.

**This test only generally recommended for workshop activities.**

## ■ Temperature Calibration Check / Recalibration

**Tools required:**

- 1 x Calibrated digital thermometer
- 1 x Temperature probe on a heat sink

1. Place temperature probe in the centre of cavity
2. Ensure the oven is in 'Full Serve Mode' (green ticked box) and not in Manual Mode (red ticked box)

3. Select 250°C oven temperature. If there is no preheat temp programmed appropriate for the oven test, a new temperature must be programmed into a spare location. (250°C)

4. Wait for the oven to reach the preheat temperature of 250°C

5. When the easy touch screen is displayed press the chef's hat.

6. Ensure oven temperature is displaying the temperature appropriate for the calibration test (250°C)

7. Press the timer icon and select 10 minutes

8. Ensure the fan speed is set for 100% and the microwave power is set to 0%, if not correct by selecting each

9. Press the green tick at the bottom of the screen

10. Press the start icon on the bottom right of the screen and you will then be asked to confirm that product is in the oven. Select the tick to confirm

11. When the timer has 30 seconds remaining press the temp icon the temperature the oven sensor thinks the cavity has reached will be displayed prefixed with \*

12. Compare the displayed temperature with the actual temperature shown on the digital thermometer. Recalibration will be required, and should be carried out swiftly, if the readings are outside the following guidelines;

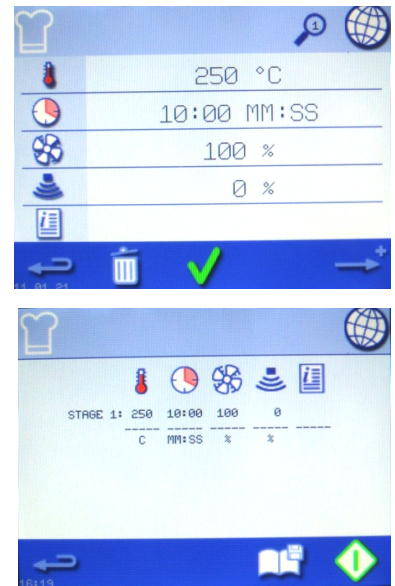

Model	Preheat	Display	Thermometer	Action
e2s	250°C	*250°C	246°C or higher	Recalibrate
			239°C or lower	Recalibrate
			240°C to 245°C	No action required

13. To recalibrate, promptly access the temperature calibration selection (Temp Comp) in the service mode

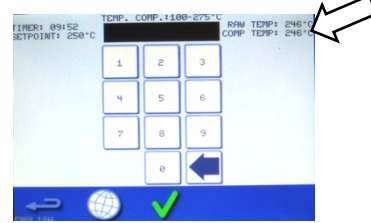
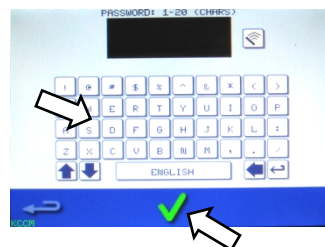
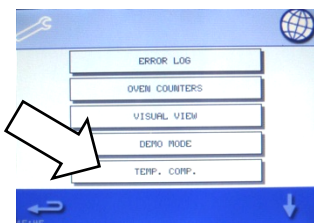

14. Press the 'temp comp' icon

15. The next screen will prompt you for a password "tcomp" should be entered here in lower case (if this does not work the oven serial number should be entered).

16. In this screen use the actual temperature observed on the digital thermometer in step 12, add 5°C and enter the combined number (i.e. actual temp = 245 + 5 = 250). This "250" should be entered into this screen then the green tick pressed to confirm the setting. Check the entered temperature is now visible as the "Comp Temp:".

17. Press the backspace in the bottom left-hand corner three times to return to the easy touch screen.

18. Repeat the calibration check, points 5 to 12. Retesting to check that the cavity temperature reading is now within the recommended guidelines.

**If the temperature reading is unstable and not calibrating correctly:**

1. Disconnect and isolate the appliance from the electricity supply and Lock off, see section 2.14 'Safe working when testing components'.

2. Take protective measures to ensure the power cannot be switched on again.
3. Allow the appliance to cool down.
4. Remove the side and top panels of the casing.
5. Check the cavity temperature sensor wire and connections.
6. If the wire and connections are correct and in good condition, replace the cavity temperature sensor (see Section 6.16. – Overview - further components).
7. Refit the panels of the casing.
8. Switch ON the appliance and repeat the test procedure as described above.
9. If the temperature is still unstable repeat steps to make safe and replace the SRB (see Section 6.9 Replacing the SRB).
10. Refit the panels of the casing.
11. Switch ON the appliance and repeat the test procedure as described above.

## 5.7 Recommissioning test

### Recommissioning test:

Recommissioning the appliance after service/repair has been completed on all service calls

The recommission tests are performed following the completion of a service or repair to ensure that the appliance is working correctly before handing back to the customer.

Some of the tests have a countdown timer, where failing to carry out a test within the time limit will cause a test failure and the recommission test will have to be restarted.

If the 'recommission test' tab is greyed out, the oven is above 200°C and will not allow to the test to commence until the oven is cooled down.

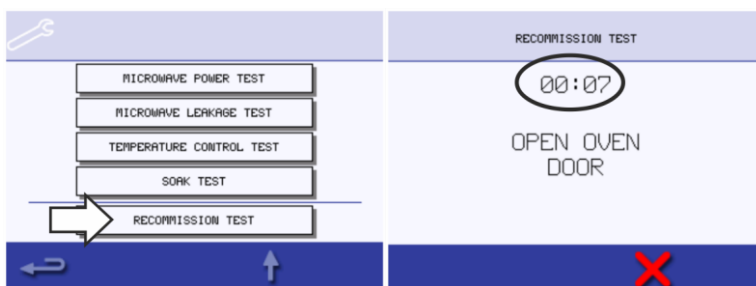

1. Select 'recommission test' from the Service Mode oven tests and follow the on screen instructions to perform the tests.  
Do not select the red 'X' unless you want to stop the test.

The test will check in the following order;

- Door switch operation
- Filter switch operation
- Microwave circuits
- Heater circuit
- Convection fan operation
- Cooling fan operation

The test will stop at any point a failure is detected.

2. After a test has successfully passed, select the green check mark to continue.

3. When all the tests have been successfully performed the display shows the recommission test has passed. Select the green check mark to confirm.

4. In the event of a recommission test failure, the detail will be recorded in the Error Log.

Rectify any error and repeat the recommission test.

Note: If the door is opened during the 12 second microwave circuit test, or the 19 second heater circuit test, the test will stop and reset the timer, commencing again once the door is closed.

## Commissioning the oven after service/repair/testing

**Complete the following checks after the oven has been serviced/repaired/tested before connecting to the mains electricity power supply:**

1. All internal electrical connections are correct (see "Electrical circuit diagrams" in section 7).
2. All wiring insulation is correct and is not touching any sharp edges.
3. All grounding connections are electrically and mechanically secure.
4. Any removed heat tape or cable ties are refitted/replaced.
5. All door safety interlocks are secure and mechanically sound.
6. The door activates all of the door interlock switches and in the correct order.
7. The door operation is smooth.
8. The door seal is in good condition and seals against the cavity
9. The casing is securely refitted with no trapped wires and all of the fixing bolts are refitted.

**Before finishing a service call, recheck the following points:**

1. Run the recommission tests to ensure the oven is functioning correctly and the touch screen is working.
2. Microwave emissions are below the permissible limit of  $5\text{mW}/\text{cm}^2$ , ideally  $<0.5\text{mW}/\text{cm}^2$ .
3. The power output of the oven is checked in accordance with the procedure.
4. Earth leakage is within permissible limits.
5. The oven has a correct air gap of 50 mm / 2 inches above. Air flow should not be restricted at the front, top or rear of the oven.
6. Complete the service report.

## 5.8 High voltage components (casing removed)

### High voltage transformer test

Ensure the following requirements have been met before starting the test:

- The appliance has been disconnected from the power supply and protective measures have been taken to ensure the power cannot be switched on again.
- The appliance is cool.
- The high voltage capacitors are discharged before commencing work. See section 2.15 'How to discharge the e2s HV'.
- The casing of the appliance has been removed.

Note: the left hand transformer connects to the right hand HV components

#### **⚠ DANGER**

**High voltages and significant currents are present at the high voltage capacitor and HV Circuit.**

It is very dangerous to work near this part when the oven is on.

NEVER make any electrical measurements on the high voltage circuits, including the magnetron filament, whilst the oven is connected to the mains power supply.

1. Remove all connections from the transformer.
2. Using a Digital Multi-Meter (DMM), check the resistance of the windings.  
Results should be as follows:

- 200 – 230V Transformer

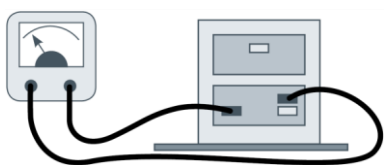

3. Mains winding between tags, approx.;
- |             |              |
|-------------|--------------|
| 0 to 230;   | 0.6 $\Omega$ |
| 0 to 200;   | 0.5 $\Omega$ |
| 200 to 230; | 0.1 $\Omega$ |

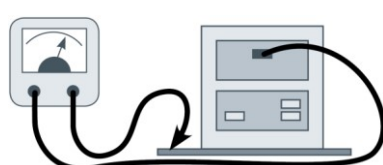

4. High Voltage winding, approx. 57  $\Omega$ .

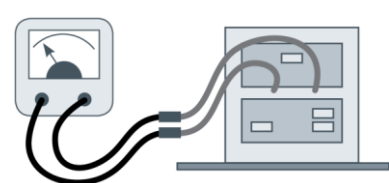

5. Filament winding between terminals, less than 1  $\Omega$ .

- 208 – 240V Transformer

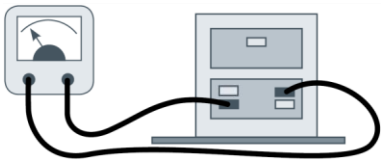

**3.** Mains winding between tags, approx.;

0 to 200/208;	0.5 $\Omega$
0 to 220;	0.6 $\Omega$
0 to 240;	0.6 $\Omega$
208/208 to 220;	0.1 $\Omega$
208/208 to 240;	0.1 $\Omega$
220 to 240;	0.1 $\Omega$



**4.** High Voltage winding, approx. 47  $\Omega$ .

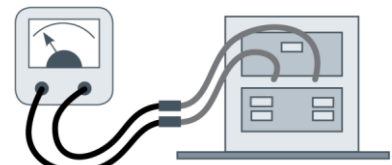

**5.** Filament winding between terminals, less than 1  $\Omega$ .

**6.** Using a megger/insulation tester, test the insulation resistance between:

Primary winding and chassis. Pass if reading is over 10 M $\Omega$

Filament winding and chassis. Pass if reading is over 10 M $\Omega$

NOTE: One end of the high voltage (secondary) winding is connected to the chassis, so this is not

## ■ High voltage diode test

Ensure the following requirements have been met before starting the test:

- The appliance has been disconnected from the power supply and protective measures have been taken to ensure the power cannot be switched on again.
- The appliance is cool.
- The high voltage capacitors are discharged before commencing work.  
See section 2.15 'How to discharge the e2s HV'
- The casing of the appliance has been removed.

### ⚠ DANGER

**High voltages and significant currents are present at the high voltage capacitor and HV Circuit.**

It is very dangerous to work near this part when the oven is on.

NEVER make any electrical measurements on the high voltage circuits, including the magnetron filament, whilst the oven is connected to the mains power supply.

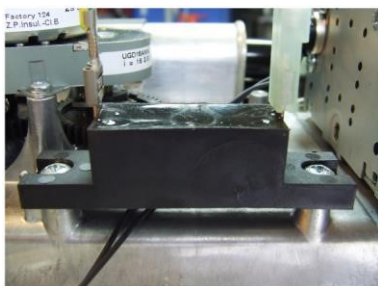

**1.** Remove both connections from the high voltage diode.

**2.** Using a megger/insulation tester, test for continuity in both directions.

Results should be as follows:

Open circuit both ways - FAIL

Conducts one-way only - PASS

Short circuit both ways - FAIL

Conducts one way, leaks the other - FAIL

## ■ High voltage capacitor test

Ensure the following requirements have been met before starting the test:

- The appliance has been disconnected from the power supply and protective measures have been taken to ensure the power cannot be switched on again.
- The appliance is cool.
- The high voltage capacitors are discharged before commencing work.  
See section 2.15 'How to discharge the e2s HV'
- The casing of the appliance has been removed.

**⚠ DANGER****High voltages and significant currents are present at the high voltage capacitor and HV Circuit.**

It is very dangerous to work near this part when the oven is on.

NEVER make any electrical measurements on the high voltage circuits, including the magnetron filament, whilst the oven is connected to the mains power supply.

1. Remove all electric connections from the high voltage capacitor.
2. Using a Digital Multi-Meter (DMM), check for continuity.

Results should be as follows:

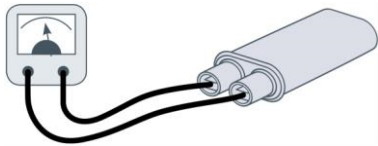

3. Connect the DMM to both terminals of the high voltage capacitor. The test is passed if the DMM display reads approx. 10 MΩ.

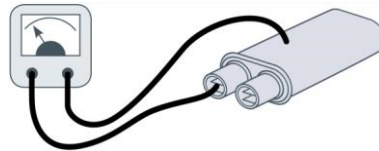

4. Connect the DMM to one terminal and the metal outer case of the high voltage capacitor. The test is passed if the DMM display reads "open circuit". Repeat the test for the other terminal and the metal outer case.

5. Using a megger/insulation tester, test the insulation resistance between both terminals and the metal outer case of the high voltage capacitor. The test is passed if the megger/insulation tester display reads over 100 MΩ.

**■ High voltage magnetron test**

Ensure the following requirements have been met before starting the test:

- The appliance has been disconnected from the power supply and protective measures have been taken to ensure the power cannot be switched on again.
- The appliance is cool.
- The high voltage capacitors are discharged before commencing work.
- The casing of the appliance has been removed.

**⚠ DANGER****High voltages and significant currents are present at the high voltage capacitor and HV Circuit.**

It is very dangerous to work near this part when the oven is on.

NEVER make any electrical measurements on the high voltage circuits, including the magnetron filament, whilst the oven is connected to the mains power supply.

1. Remove all electric connections from the magnetron.
2. Using a Digital Multi-Meter (DMM), check for continuity.

Result should be as follows:

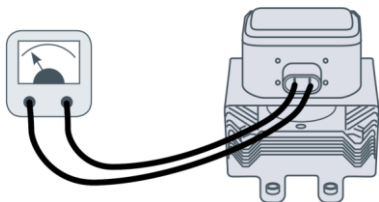

3. Connect the DMM to both terminals of the magnetron. The test is passed if the DMM display reads 1 Ω or less.

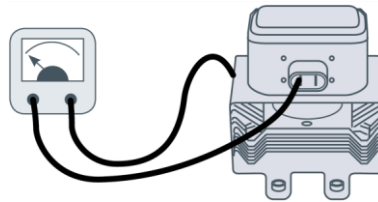

4. Using a megger/insulation tester connect to one terminal and the metal outer case of the magnetron. The test is passed if the megger/insulation tester display reads an infinite resistance, "open circuit". Repeat the test for the other filament terminal and the metal outer case.

## 5.9 Mains voltage components (casing removed)

### Convection fan: motor

The convection fan motor is a 3-phase AC motor having a maximum speed of approximately 7000 rpm (approximately 5200 rpm 16A/13A ovens) controlled by a motor speed controller.

The windings are thermally protected. In the event of a thermal fault, the trip inside the motor (IP) will open circuit and cause the oven to shut down generating the E104 / E115 error code.

### Convection fan: motor speed controller

The convection motor speed controller provides a 3-phase AC switched mode drive to the convection motor and is controlled by a 0 to 5 Volt signal from the SRB (connection X3) on 30A ovens and a 0 to 3.7 Volt signal on 13A & 16A ovens.

This allows the motor to be adjusted from approximately 1400 rpm to 7000 rpm (5200 rpm) in steps of 1%.

- Door open, Approx. 1400 rpm (10% @ 1V).
- Door closed (not cooking), Approx. 2500 rpm (31% @ 1.8V).
- Door closed heating up or 'Shutting Down', Approx. 3500 rpm (50% @ 2.5V).
- Door closed (cooking), speed as specified by program or setting up to a maximum of 7000 rpm (100% @ 5V).

### Convection fan: motor speed controller LED status display

The VDF contains two diagnostic indicators (LEDs) to display the drives operational status;

LED	Drive Status	Colour & flash Sequence	Flash rate	Colour & sequence after recovery
ST (Status)	Normal Operation (Run)	Green	1 Sec. On/Off	NA
	Overload (120%-160%Full Load)	Red	On Continuously	Green
	1st (Drive timed out)	Red	0.25 Sec On/Off	NA
	Short Circuit	Red	1 Sec. On/Off	NA
	Undervoltage	Red/Yellow	0.25 Sec. On/Off	Red/Yellow/Green
	Overvoltage	Red/Yellow	1 Sec. On/Off	Red/Yellow/Green
	Stop	Yellow	On Continuously	NA
	Phase Loss Detection	Yellow	0.05 Sec. On/0.06 Sec. Off	NA
PWR (Power)	Bus and Logic Power Supply	Green	On continuously	NA

### Convection fan: motor speed controller control voltages & linkage positions

Oven Variant	13A, 15A/16A & 20A	30A
Input %	0 - 5 Volts	
10	1	1
20	1.4	1.4
30	1.8	1.8
40	2.2	2.2
50	2.5	2.5
60	2.7	3
70	3	3.5
80	3.2	4
90	3.5	4.5
100	3.7	5

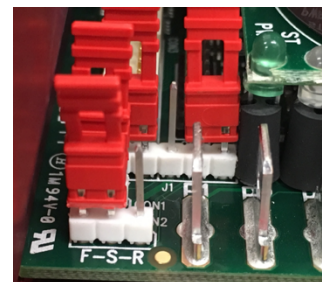
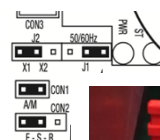

Linkage positions are factory pre-set based on the model of convection fan used in the e2s. The link positions must not be altered without express instruction from Merrychef.



## ■ Convection fan: motor and motor speed controller tests

Ensure the following requirements have been met before starting the test:

- The appliance has been disconnected from the power supply and protective measures have been taken to ensure the power cannot be switched on again.
- The appliance is cool.
- The high voltage capacitors are discharged before commencing work.
- Anti-static precautions have been taken.
- The casing of the appliance has been removed.

Check the following:

1. All associated wiring and connections, from SRB X3 & X9 through the speed controller to the convection fan motor.
2. Convection fan motor thermal cut-out (IP), two grey wires.
3. Convection fan motor rotates freely / not seized.
4. Convection fan motor winding resistances:
  - Blue-black  $9 \Omega \pm 10\%$
  - Black-brown  $9 \Omega \pm 10\%$
  - Brown-blue  $9 \Omega \pm 10\%$
  - Black or brown or blue to earth (open circuit).
5. With the oven panels refitted and the oven re-connected to the power supply check the fan speeds using visual view in the service mode.

Finally, If all suitable precautions (including where necessary the provision of suitable protective equipment) have been taken to prevent injury;

Check the following:

6. Speed controller LED status
7. Electrical supply to the speed controller

## 5.10 Optional components (casing removed)

### Kitchen Connect Control Module (KCCM)

Optional Ethernet / WIFI communications module for remote connectivity through KitchenConnect. Installed on the inside of the rear panel and connected to the SRB, X12 & X13.

KCCM Module LED	Colour	Information
LED1	Red	12VDC power from SRB
LED2	Orange	5VDC power for additional components
LED3	Orange	5VDC power
LED4	Yellow	3.3VDC power
LED5	Blue	WIFI status
LED6	Green	Processor status

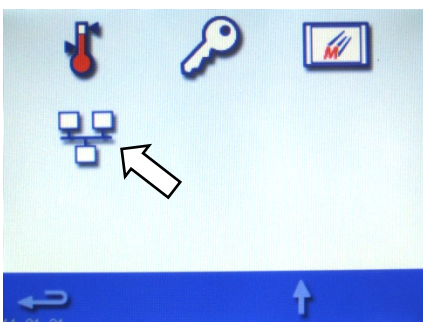

Connection details can be accessed from the settings menu.

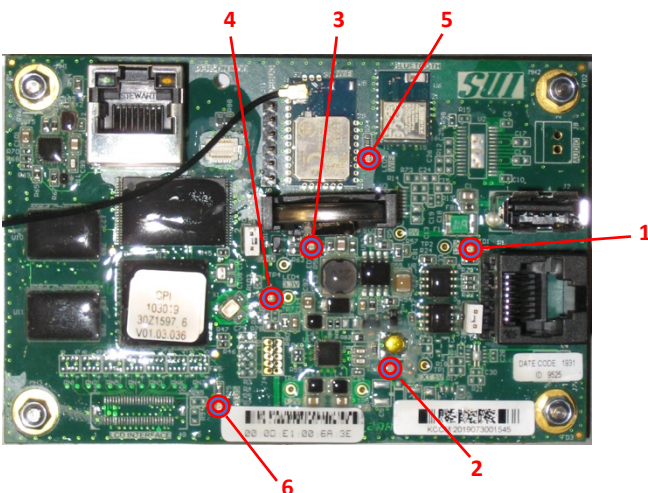

LED positions ~ 

## 6 Replacing components

### 6.1 Safe working when replacing appliance parts

#### For your safety when replacing appliance parts

Before starting service / repair work, it is essential that you familiarize yourself with the rules and hazard warnings specified in section 2 'For your safety', specifically section 2.16 'Safe working when replacing appliance parts'.

#### Tools required

HV Capacitor discharge tool  
 Digital Multi-Meter (D.M.M.)  
 Proprietary voltage detector  
 Electrical lock out tools & equipment  
 Door spacer kit (2 x 4mm & 2mm Spacers)  
 M2 hex key socket  
 M5.5 hex socket wrench / nut runner  
 M5.5 hex open / ring spanner  
 M7 hex socket wrench / nut runner  
 M7 hex open / ring spanner  
 M8 hex socket wrench / nut runner  
 M10 hex socket wrench / nut runner  
 M14 hex socket wrench / spanner

Torque wrench  
 Stanley / retractable knife  
 Sealant gun  
 Long handled Pozidriv screwdriver PZ1  
 Long handled Pozidriv screwdriver PZ2  
 Flat screwdriver or lever  
 Pliers (or M14 ring spanner)  
 Two metal pins, 3mm diameter & 10mm long  
 Two metal pins, 2 to 3mm diameter & 40mm or longer in length  
 Hammer (for removing pressed screws from a spare magnetron)  
 M3 hex key socket

### 6.2 Overview

#### View: left hand side

Optional KCCM location (35)

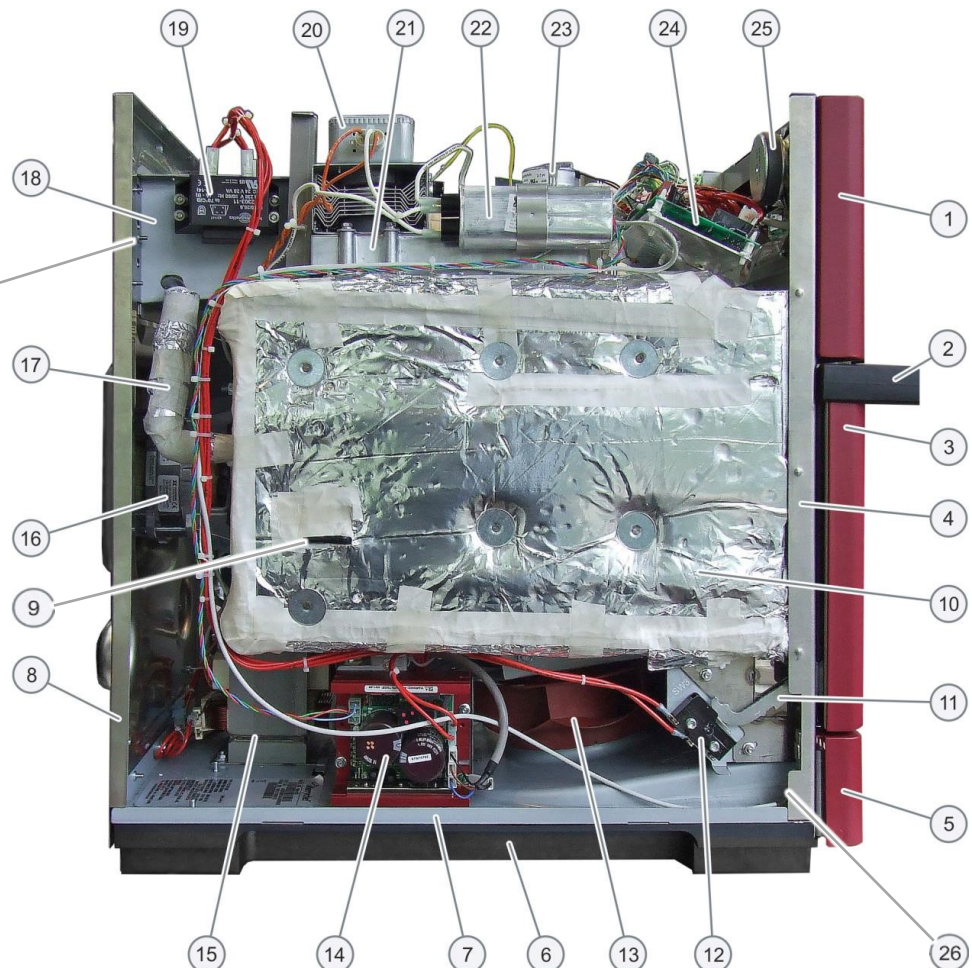

■ View: right hand side

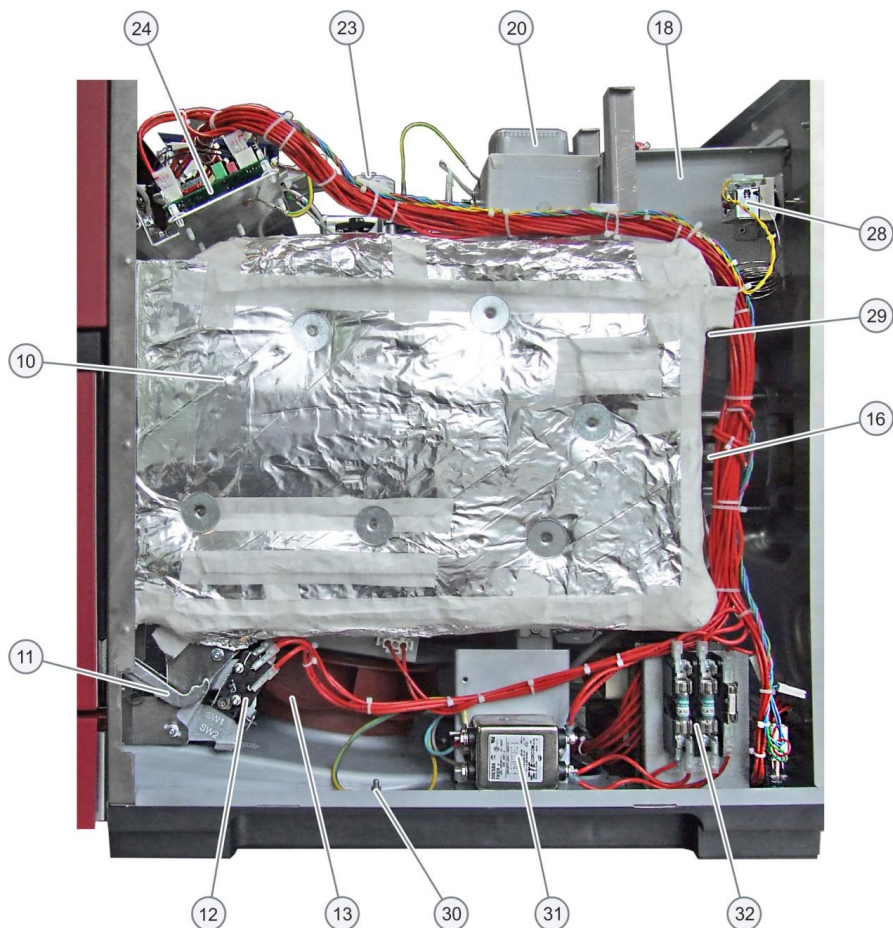

■ View: rear side

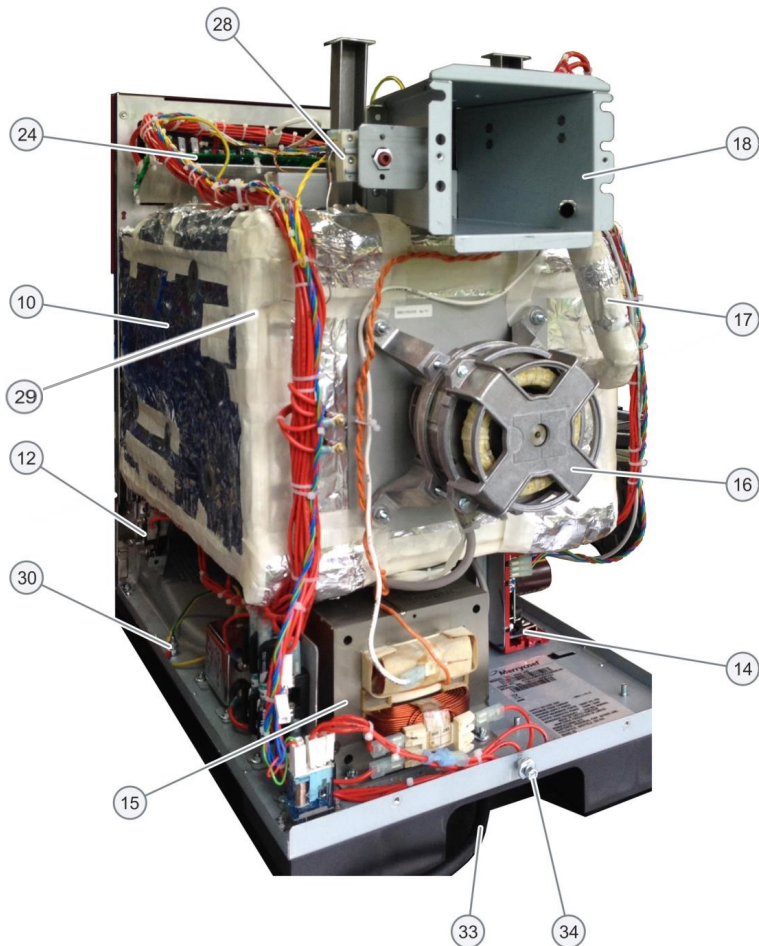

## Component list

Item	Name	Function
1	Front panel	The front panel houses the touchscreen QTS assembly and the on/off switch
2	Door handle	Open the oven door using the door handle. Never use the door handle to lift the appliance.
3	Door cover panel	The door cover panel can be detached for accessing the door hinge assembly.
4	Cavity Frame	The oven door and front panel are mounted on the cavity frame, with the top and side panels clipping on to the edges
5	Air filter faceplate	The faceplate can be tilted to access the air filter.
6	Foot	The oven rests on a high quality plastic foot extending over the whole length of the appliance.
7	Base plate	The metal base plate carries all oven components.
8	Back panel	The back panel, fitted to the base plate & cooling duct, secures the oven top & side panels and provides ventilation of the oven interior.
9	Thermocouple	Provides the cavity temperature signal to the SRB
10	Cavity & Cavity Wrap	The insulated cavity (cooking chamber) for cooking food can be accessed by opening the oven door.
11	Door hinge assembly	The door hinges interact with the microswitches / interlocks.
12	Door microswitch(es) / interlock(s)	The microswitches / interlocks are connected to the door hinges and switch off the magnetron(s) when the oven door is opened.
13	Cooling fan	The cooling fan draws air through the air filter into the interior of the casing in order to cool the electrical components.
14	Convection (hot air) fan motor speed controller	This component controls the speed of the convection fan motor depending on specific oven settings.
15	Transformer (high voltage) (2000W e2s variant: 2x)	A high voltage transformer feeds the HV microwave circuit.
16	Convection (hot air) fan motor	The convection fan motor is controlled by the speed controller and drives the convection fan for air flow within the oven cavity.
17	Exhaust pipe	The exhaust pipe leads excessive steam from the cavity to the cooling duct and the rear air outlet of the oven.
18	Cooling duct	The cooling duct directs heat generated by the magnetron(s) to the rear of the oven.
19	Transformer (low voltage - SRB)	The low voltage (ELV) transformer feeds the SRB.
20	Magnetron (high voltage) (2000W e2s variant: 2x)	A magnetron generates microwaves.
21	Waveguide (2000W e2s variant: 2x)	A waveguide leads microwaves from a magnetron into the cavity. The HV Diode(s) is mounted on to the waveguide(s).
22	Capacitor (high voltage) (2000W e2s variant: 2x)	The capacitor completes the magnetron circuit for required high voltage.
23	Stirrer motor (2000W e2s variant: 2x)	A stirrer motor turns a stirrer distributing microwave energy in the cavity.
24	Smart Relay Board (SRB)	The SRB controls all electrical oven components.
25	Loudspeaker	The loudspeaker produces sound signals (e.g., cooking process completed) and can be deactivated.
26	Intake Air Filter Microswitch	Closed circuit when the air filter is correctly installed
28	Cavity overheat thermostat (cavity overheat stat)	The thermostat continuously monitors the temperature in the cavity and prevents it from overheating.
29	Cavity overheat thermostat capillary	Connected to the side of the cavity, underneath the cavity wrap, for the cavity overheat thermostat temperature monitoring
30	Protective earth	Provides a chassis earthed point at the metal base plate of the oven.
31	Electromagnetic Compatibility (EMC) Filter (2000W e2s variant: 2x)	EMC filters reduce the transfer of electromagnetic noise to and from the mains power supply.
32	Mains supply fuses	The fuses protect the oven from excessive current draw.
33	Mains power supply cable	For connecting to the kitchen mains power supply.
34	Equipotential bonding connection	This is an electrical connection point to ensure that the frame of oven and any external conductive components are at an equal (or practically equal) potential when connected.
35	KitchenConnect Communications Module PCB	Optional Ethernet / WIFI communications module for remote connectivity

## 6.3 Removing / fitting the casing

### Tools required

M5.5 hex socket wrench

### Requirements

Check that the following requirements have been met:

- The appliance has been disconnected from the power supply and protective measures have been taken to ensure the power cannot be switched on again.
- The appliance is cool.

### Removing the panels of the casing

Overview of all M5.5 hex head flange bolts securing the panels of the casing.

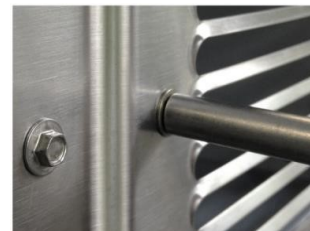
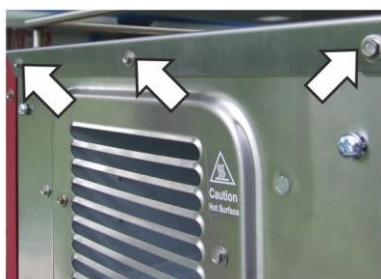
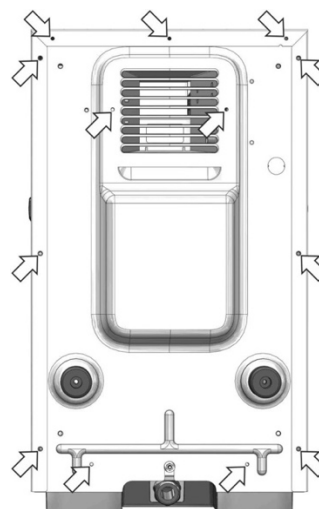
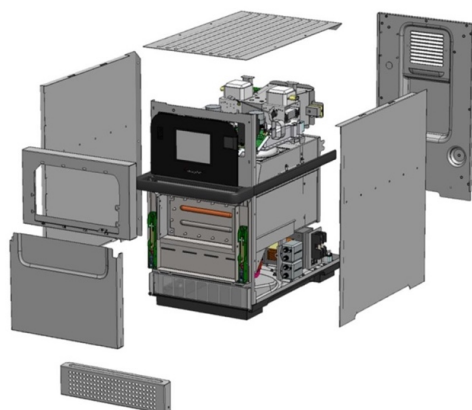

#### 1. Remove top panel first.

Unfasten the three M5.5 hex head flange bolts at the back panel of the appliance attaching the top panel to the back panel. Slide the top panel towards the back of the appliance to remove it.

#### 2. Removing the side panels:

Unfasten the six M5.5 hex head flange bolts (three per side) at the back panel of the appliance attaching each side panel to the back panel.

Slide the panels towards the back of the appliance and out at the bottom to remove them.

#### 3. Removing the back panel:

Unfasten the four M5.5 hex head flange bolts attaching the back panel to the cooling duct (two bolts) and the base plate (two bolts) of the appliance.

Move the back panel up to remove it.

Important: If the optional KCCM is fitted, disconnect the power coms lead from the module before removing the back panel.

#### 4. Ensure the high voltage capacitors are discharged before commencing any work

### Fitting the panels of the casing

Follow the steps in the reverse order to fit the panels of the casing, ensuring all 5.5M bolts are refitted and;

1. The side panels have been correctly slotted into the front cavity and base plate
2. The top panel pins have been correctly slotted into the front and side panels
3. If fitted, ensure the power coms lead is reconnected to the module (KCCM)
4. No wires have been trapped

## 6.4 Removing / fitting the door assembly

### Component

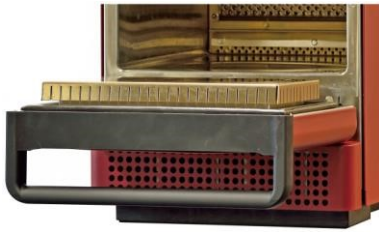

### Requirements

Check that the following requirements have been met:

- The appliance has been disconnected from the power supply and protective measures have been taken to ensure the power cannot be switched on again.
- The appliance is cool.
- Additional PPE, Mask & Gloves for handling insulation material

### Tools required

Two metal pins, 3mm diameter & 10mm long (if the door hinges are to be removed / replaced)

Two metal pins, 2 to 3mm diameter & 40mm or longer in length (if the door hinges do not require removal)

M5.5 hex socket wrench

M8 hex socket wrench

Torque wrench

PZ1 Pozidriv screwdriver

M3 hex key socket

### Removing components of the door assembly

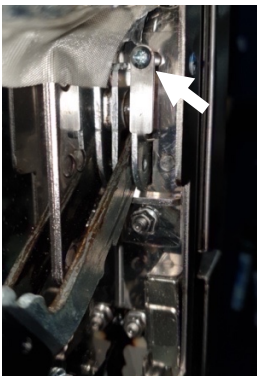

**1.** Remove the locking screw and tab from both sides.



**2.** Fully open the oven door. Insert the metal pins into the corresponding holes each door hinge, as marked up in the image, to lock the door hinge. Ensure the pins remain in this position until the door is refitted to the oven again.



**3.** Tilt the oven door up to an angle of approx. 30° from horizontal.



**4.** Remove the door assembly from the oven performing a rotational movement of lifting the door up and pulling it away from the casing. Do not use excessive force.



**5.** Unfasten the two bottom M5.5 hex head flange bolts next to the door hinges to remove the cover panel from the door frame.



**6.** Turn the door assembly around.

Slide the cover panel away from the door handle to remove it from the door frame.



**7.** Wearing gloves, remove the two thermal insulation pads located between the springs attached to the door hinges and the door handle.

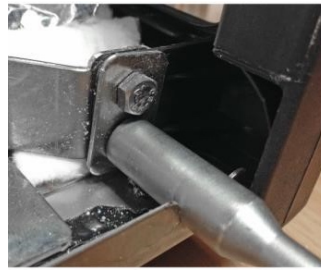

**8.** Unfasten the four M8 hex bolts (two on each side) to detach the door handle.



**9.** Wearing gloves, remove all insulation pads/mats from the



**10.** Unfasten the two M8 hex bolts for each door hinge assembly.



**11.** Remove/replace the door hinge assemblies if

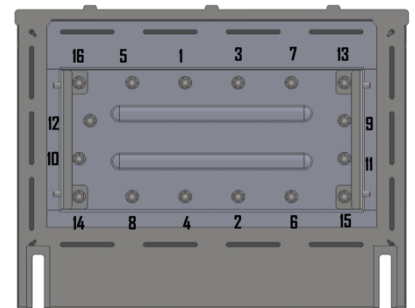

**12.** The door choke is removed by unfastening the sixteen M8 hex nuts. On refitting the door choke, ensure the studs are positioned correctly in the centre of the hole and not resting on the shoulder of the stud. The nuts should be retightened diagonally in the following sequence to 2.3 Nm.

## ■ Fitting the components of the door assembly

Follow the steps in the reverse order to reassemble the components of the oven door and fit to the oven.

## ■ Refitting the door assembly

On refitting the door to the oven, check that the door seal firmly meets the cavity frame all the way around once closed. A poor sealing door can cause issues with the oven's operation.

To set the door to the cavity correctly:

1. Refit the door to the oven with the insulation and door skin removed.
2. Close the door
3. Loosen the four M8 hex bolts holding the door hinge assemblies and push the door squarely against the cavity. Whilst holding the door in this position, tighten the four M8 hex bolts.
4. Remove the door from the oven and refit the insulation and door skin.
5. Refit the door to the oven
6. Close the door and recheck that the door seal tightly meets the cavity frame all the way around.

Refit the door to the oven in the reverse order to removal. Ensure the hinges locate correctly before reinstalling the locking tabs. Once refitted, ensure the door switch settings and operation is correct.

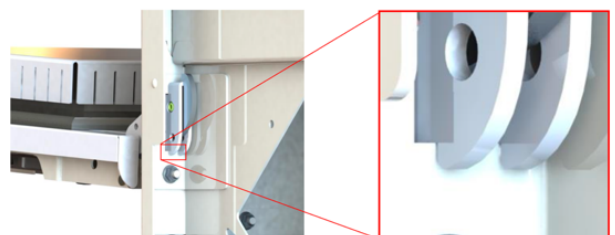

NOTE: ENSURE BOTTOM OF HINGE IS FULLY ENGAGED BEFORE REMOVING HINGE SAFETY PINS.





## 6.5 Replacing the door gasket

### Tools required

Suitable gloves  
Stanley / retractable knife  
High temperature sealant  
Cloth for wiping residue

### Requirements

Check that the following requirements have been met:

- The appliance has been disconnected from the power supply and protective measures have been taken to ensure the power cannot be switched on again.
- The appliance is cool.

**1.** Place a Stanley / retractable knife blade underneath the door seal and go all the way to break the seal.

Ensure you do all four sides avoiding the metal clips on each corner.

Please ensure all safety aspects are adhered to while working with a sharp knife

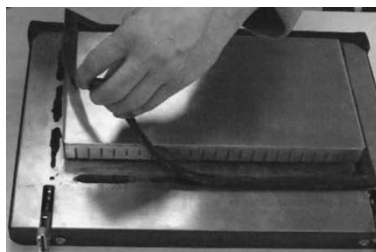

**2.** Gently pull the metal clip out of each corner and lift off the door seal.

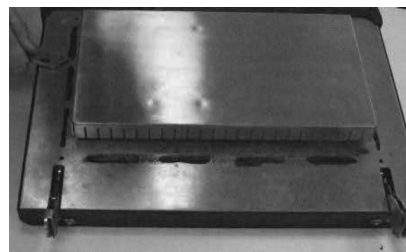

**3.** Remove remaining residue sealant using the knife or similar to make the surface is as flat and clean as possible.



**4.** Apply a continuous thin bead of Merrychef approved high temperature sealant around the existing door seal area. Ensure you do all four sides.

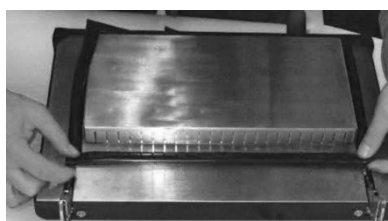

**5.** Place the new door seal over the door in the same place as the old one and insert the metal clips in each corner.



**6.** Press down firmly to tightly secure the door seal onto the door. Ensure it is level and square. Wipe off any excess sealant protruding for the door seal.

**7.** Leave to dry naturally. It will need 24 hours to dry but the heat of the oven can also be used to dry the sealant, speeding up the process.



**8.** Refit the door (if removed) and close. Open and close to check the operation and ensure the seal does not move. Leave the door closed and let the sealant cure.

Note: The door seal can be replaced without removing the door from the oven

### Heating up the oven to dry the seal

1. Switch the oven on and let it heat up to 250°C (482°F)
2. Keep the door shut for two hours.

The oven will be ready for usage again after 2 hours

### **⚠ WARNING**

**Never use the oven without the door seal attached properly.  
Never switch on the oven without the door attached and closed.**

## 6.6 Replacing a magnetron

### Component

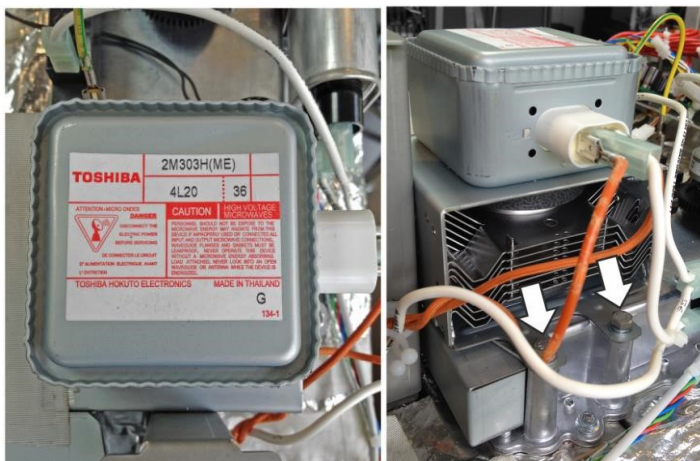

The magnetron(s) is/are located on top of the cavity and is/are fixed to the cooling duct and the cavity roof.

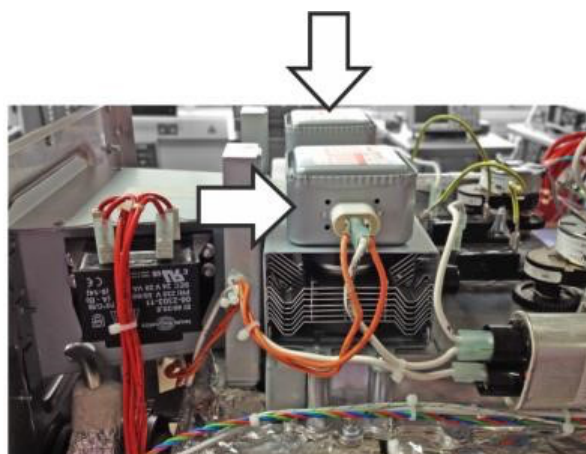

The 2000W e2s variant comprises two magnetrons located on the left and right hand sides of the cooling duct.



The cooling duct covers one side of the magnetron where the magnetron is attached to the cavity roof with two screws.  
*The image shows a single magnetron 1000W e2s variant.*



The outlet of the cooling duct carries heat to the back of the oven and is covered by a grille.  
The outlet comprises a sheet metal frame containing holes corresponding to the positions of Pozidriv screws securing the cooling duct to the magnetron.  
Use these holes for guiding the Pozidriv screwdriver.

### Tools required

- Hammer or similar tool
- PZ2 Pozidriv screwdriver
- M8 hex socket wrench
- Torque wrench
- Discharge Tool

### Requirements

Check that the following requirements have been met:

- The appliance has been disconnected from the power supply and protective measures have been taken to ensure the power cannot be switched on again.
- The appliance is cool.
- The top, left and right panels of the casing of the appliance have been removed.
- The high voltage capacitors are discharged before commencing work.

## ■ Preparing a replacement magnetron

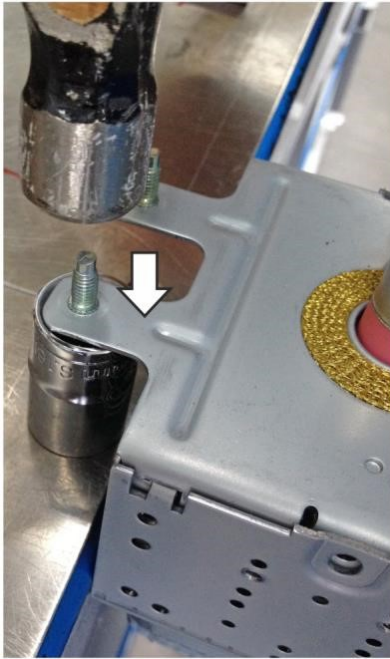

**1.** The new magnetrons come with four pressed studs for fixing. These studs need to be removed before fitting the magnetron to the oven.

**NOTE:**

The studs can be removed by knocking them out of the tabs with a hammer.

Ensure the tabs are not bent during this process. Secure them by laying them upon a piece of tube while pushing out the studs.



**CAUTION**

**Wear personal protective equipment to protect your fingers when using the hammer.**

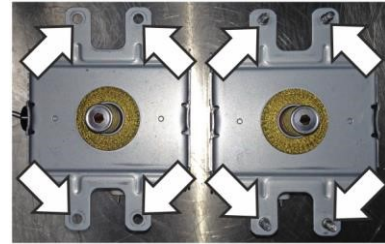

**2.** Comparison of spare magnetrons with (right) and without (left) pressed studs.

## ■ Removing a magnetron

1. Carefully peel back the sealing tape on the cooling duct (keep for reuse).
2. Unplug the magnetron high temperature thermostat(s).

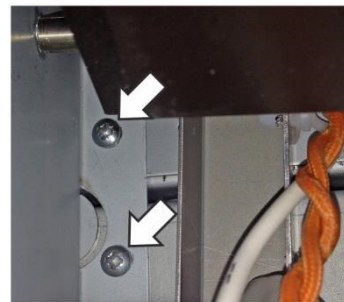
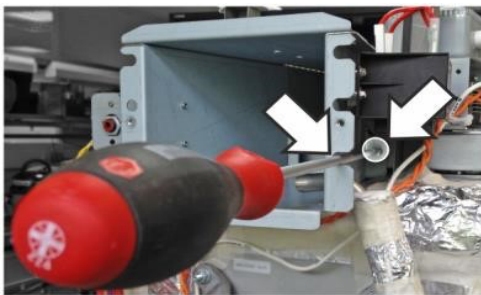

3. Unfasten the three Pozidriv screws on the right hand side of the cooling duct with a long PZ2 Pozidriv screwdriver using the corresponding access holes at the cooling duct (when looking at the back side of the oven).

**NOTE:** The picture shows the right side of the cooling duct seen from the outlet of the ducting

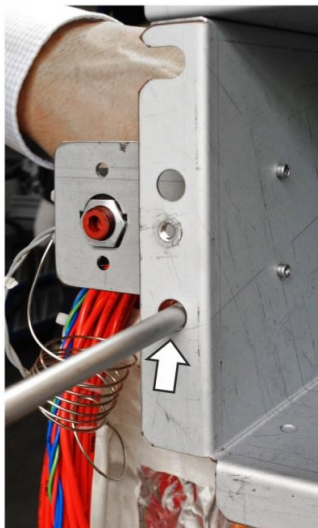

4. Unfasten the one Pozidriv screw on the left side of the cooling duct with a long PZ2 Pozidriv screwdriver using the corresponding access hole at the cooling duct (when looking at the back side of the oven).

**NOTE:** The number of screws on the left side of the cooling duct depends on the number of magnetrons fitted.

One magnetron (1000W e2s variant) one screw

Two magnetrons (2000W e2s variant) three screws

**NOTICE: When detaching the cooling duct be careful not to damage the exhaust pipe leading into the duct, the cavity overheat thermostat or the LV transformer**

If removing the cooling duct from the oven the cavity overheat thermostat should be disconnected from the bracket using a 14mm socket or spanner and the wires should be disconnected

5. Disconnect the wiring from the magnetron(s)

6. Unfasten the four M8 hex cap bolts to remove the magnetron. There is one pair of bolts on each side of the magnetron. Disconnect any cables leading into the magnetron(s).

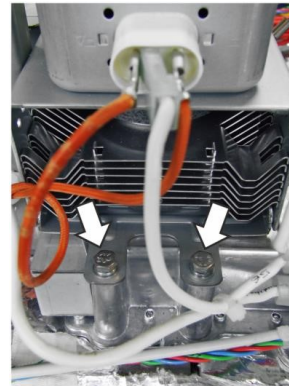
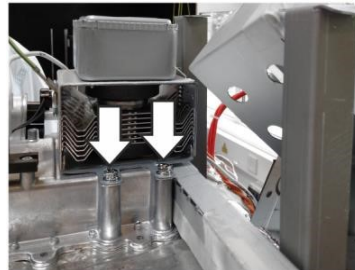

7. Remove the magnetron overheat thermostat(s) for refitment on to the replacement magnetron(s).

### ■ Fitting a magnetron

- Follow the steps in the reverse order to fit a replacement magnetron.
- Ensure the magnetron overheat thermostat is refitted in the same location to ensure correct operation.
- Ensure the RF (Radio Frequency) gasket is correctly seated.
- Fit all of the M8 bolts loosely, then tighten in a cross pattern to ensure the magnetron seats evenly.

### ⚠ WARNING

**Ensure nothing becomes trapped under the magnetron mounting points (e. g. insulation material) while fitting the magnetron. This can lead to microwave leakage.**

NOTICE:

If the electric connections have not been restored properly this may lead to malfunction/damage of the oven.

## 6.7 Replacing the cooling fan

### ■ Component

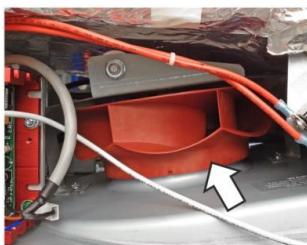

The cooling fan is located under cavity and can be accessed by removing the convection fan motor speed controller.

### ■ Tools required

M7 hex socket wrench  
Discharge Tool

### ■ Requirements

Check that the following requirements have been met:

- The appliance has been disconnected from the power supply and protective measures have been taken to ensure the power cannot be switched on again.
- The appliance is cool.
- The top, left and right panels of the casing of the appliance have been removed.
- The cooling fan speed controller is removed.
- The high voltage capacitors are discharged before commencing work. Discharge cap with discharge tool across both pins on the 3 pin Molex connector.

### ■ Removing the cooling fan

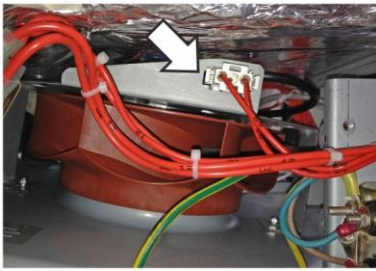

1. Unplug the electrical connection of the cooling fan on the right hand side of the appliance.

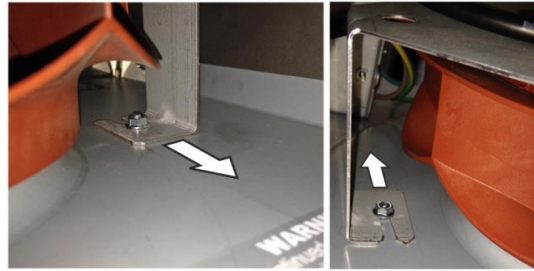

2. Loosen the two M7 hex nuts each securing one arm of the sheet metal bracket which holds the cooling fan. Then turn the bracket clockwise.

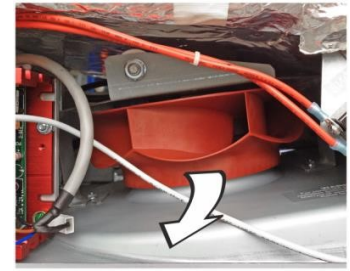

3. Twist and remove the cooling fan via the left hand side of the oven (when looking at the oven from the front).

### ■ Fitting the cooling fan

Follow the steps in the reverse order to fit the cooling fan.

#### NOTICE:

If the electric connections have not been restored properly this may lead to malfunction/damage of the oven.

## 6.8 Replacing the QTS (Quick Touch Screen) assembly

### ■ Component

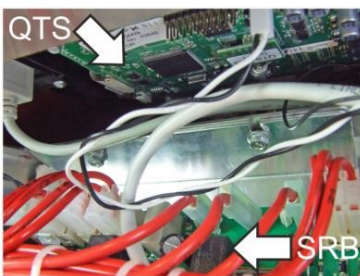

Top section (picture on the left):

The QTS (Quick Touch Screen) is attached to the front panel of the oven.

The much larger SRB (System Relay Board) extends over the whole width of the oven and rests on a tilted position close to the front panel of the oven. It is mounted to the top of the cavity frame.

### ■ Tools required

M5.5 hex socket wrench / nut runner  
M2 hex key socket

### ■ Requirements

Check that the following requirements have been met:

- The appliance has been disconnected from the power supply and protective measures have been taken to ensure the power cannot be switched on again.
- The appliance is cool.
- Anti-static precautions have been taken.

### ■ Removing the QTS assembly

1. Unfasten the M5.5 hex head flange bolt under the plastic front fascia (Control D)



2. Slide the black facia 5mm to the left and pull forward
3. Disconnect the plug to the on/off switch board and the RJ45 communication cable & speaker cable from the QTS
4. Disconnect the USB extension cable from the QTS



5. Unfasten the four M2 (2mm) hex key bolts to remove the QTS assembly from the front panel.

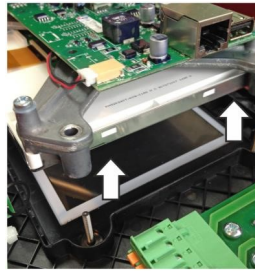

6. Lift out the QTS assembly.

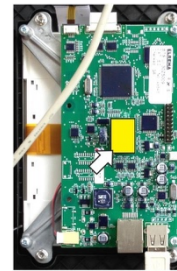

7. Remove the PM (Personality Module) from the QTS and place safely aside.  
**NOTICE: Do not use tools to remove or refit the personality module.**

## ■ Fitting the QTS assembly

Follow the steps in the reverse order to replace the QTS assembly, fitting the removed PM from the old QTS to the new QTS.

**Reason:** Replacement QTS / SRB units come WITHOUT personality modules as they store individual settings saved by the user. For details see "QTS Terminal Locations" in section 7.

Ensure the cables are not trapped when refitting the facia.

### NOTICE:

If the electric connections have not been restored properly this may lead to malfunction/damage of the oven.

## 6.9 Replacing the SRB (Smart Relay Board)

### ■ Component

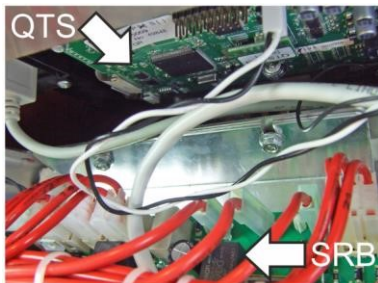

The much larger SRB (Smart Relay Board) extends over the whole width of the oven and rests in a tilted position close to the front panel of the oven. It is mounted to the top of the cavity frame.

The QTS (Quick Touch Screen) board is attached to the front panel of the oven.

### ■ Tools required

M7 hex socket wrench / spanner  
Discharge Tool

### ■ Requirements

Check that the following requirements have been met:

- The appliance has been disconnected from the power supply and protective measures have been taken to ensure the power cannot be switched on again.
- The appliance is cool.
- The side and top panels of the casing of the appliance have been removed.
- The high voltage capacitors are discharged before commencing work.
- Anti-static precautions have been taken.

### ■ Removing the SRB



1. Disconnect all cables connecting the SRB to other components.

2. Loosen the two M7 hex nuts to remove the SRB from the frame of the casing.

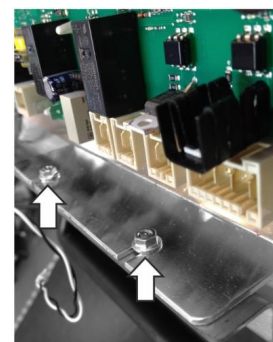



3. Remove the PM (Personality Module) from the SRB and place safely aside.

**NOTICE: Do not use tools to remove or refit the Personality Module.**

### ■ Fitting the SRB

Follow the steps in the reverse order to fit the SRB. For details see “SRB Terminal Locations” in section 7.

Refit the Personality Module (PM) removed from the old SRB to the new SRB.

Reason: Replacement QTS / SRB units come WITHOUT Personality Modules as the PMs store individual settings saved by the user. Ensure the original PM Module is fitted from the old SRB/QTS and placed in the new SRB/QTS.

**NOTICE:**

**If the electric connections have not been restored properly this may lead to malfunction/damage of the oven.**

## 6.10 PM (Personality Module) Replacement

### ■ Fitting the SRB Personality Module (PM)

#### ■ Requirements

Check that the following requirements have been met:

- The appliance has been disconnected from the power supply and protective measures have been taken to ensure the power cannot be switched on again.
- The appliance is cool.
- The side and top panels of the casing of the appliance have been removed.
- The high voltage capacitors are discharged before commencing work.
- Anti-static precautions have been taken.

The personality module on the SRB contains the SRB dedicated firmware and the error log file.

1. Unplug the old PM from SRB and fit replacement PM (ensure part number is correct).
2. Refit all oven panels, plug in oven and switch on.
3. Tap the screen to hold and check the SRB and QTS (UI) versions are the latest release. If not, execute a firmware update using the latest versions. See section 4.5 for details.
4. Recommission the oven in service mode.

### ■ Fitting the QTS Personality Module (PM)

#### ■ Requirements

Check that the following requirements have been met:

- The appliance has been disconnected from the power supply and protective measures have been taken to ensure the power cannot be switched on again.
- The appliance is cool.
- Anti-static precautions have been taken.

The personality module on the QTS contains the firmware, serial number of the oven, temperature calibration, cooking profiles, application icons and the recipe images.

1. Unfasten the M5.5 hex head flange bolt under the plastic front facia (Control D)
2. Slide the black facia 5mm to the left and pull forward
3. Unplug the old PM from QTS and fit replacement PM (ensure part number is correct).
4. Refit control D panel, plug in oven and switch on.
5. Once booted up the follow the screen instructions;
  - The first screen will ask for the oven serial number, add the number from the serial plate on the oven. Ensure this is correct before confirming by the green tick icon.
  - Once confirmed, the next input screen will ask which power rating the oven is. This can be determined from the first two letters after 'e2s' in the oven model (item) number. For example;
    - DB (32A plug) = 30A
    - FX (16A plug) = 16A
    - GX (13A UK plug) = 13A

Again, ensure the selection is correct before confirming by the green tick. This is imperative as it changes the oven functions based on the selection.

- Once confirmed the oven serial number and power selection cannot be changed without replacing the QTS PM again.
6. Tap the screen to hold and check the SRB and QTS (UI) versions are the latest release. If not, execute a firmware update using the latest versions. See section 4.5 for details.
  7. Reload the operators menu file.
  8. Check the time, date and day are correct in the settings.
  9. Recommission the oven in service mode.



## 6.11 Replacing the touchscreen overlay

### Requirements

Check that the following requirements have been met:

- The appliance has been disconnected from the power supply and protective measures have been taken to ensure the power cannot be switched on again.
- The appliance is cool.

### Tools required

Flat headed screwdriver

### Replacing the touchscreen overlay

The touch screen overlay surrounds the easyTOUCH® screen providing easy-to-clean protection from electrical connections. Should it fail, it can be removed by prising away from the front of the appliance with a flat headed screwdriver and pull off in one go. The adhesive should be removed from the appliance using an alcohol based cleaner before the replacement is applied.

### Fitting the touchscreen overlay

Once the plastic facia panel (Control D) has been cleaned and free from cleaning residue carefully position the new overlay and press firmly in place.





## 6.12 Adjusting the door microswitches/interlocks

### Component



Adjust the microswitches after replacing old with new door hinges. Microswitch alignment is not required if just refitting the same door, but the correct operation should be checked.

### Requirements

Check that the following requirements have been met:

- The appliance has been disconnected from the power supply and protective measures have been taken to ensure the power cannot be switched on again.
- The appliance is cool.
- The top and side panels of the casing of the appliance have been removed.
- The high voltage capacitors are discharged before commencing work.

### Tools required

M7 hex socket wrench  
Spacer kit  
Discharge Tool

### Adjusting the door microswitches

Located on the oven cavity frame are 3 safety interlock microswitches, to prevent microwave emissions escaping when the oven door is opened:

- The primary microswitch (SW3), located on the left hand side of the oven, breaks the electrical supply circuit to the HV transformers.
- The secondary microswitch (SW2), located on the right hand side of the oven (outer), breaks the microwave circuit if the primary (SW3) fails.
- The monitor microswitch (SW1), located on the right hand side of the oven (inner), will short out the microwave circuit blowing the F2 fuse if both secondary microswitch (SW2) fails.

#### IMPORTANT:

**In the event that the monitor switch (SW1) causes the microwave circuit F2 fuse to blow, the secondary (SW2) and monitor (SW1) microswitches must be replaced due to exposure to high short-circuit currents.**

The purpose of the following adjustment procedure is to set the interlock to switch off the microwave circuit when the door is opened more than 4 mm and for the microwave circuit to operate when the door is closed, and the door seal expands.

1. Open the appliance door and position the two green 2mm spacers over the top corners of the door seal. Then carefully close the door ensuring the spacers are still in position.

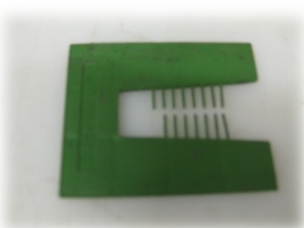

2. Slacken the pivot nut using a M7 hex socket wrench.

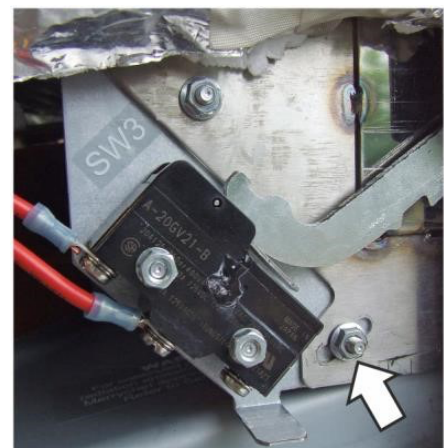

3. Release the adjusting M7 nut and move the backplate until microswitch SW3 just activates (closes). Then tighten both nuts.

4. Open the appliance door to replace the green 2mm spacers with the two red 4mm spacers. Then carefully close the door ensuring the spacers are still in position.

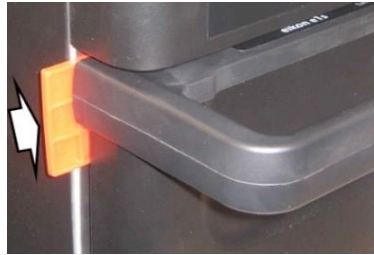
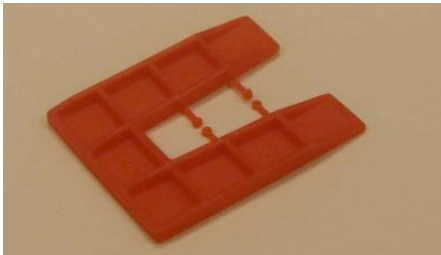

5. Slacken the pivot nut using a M7 hex socket wrench.

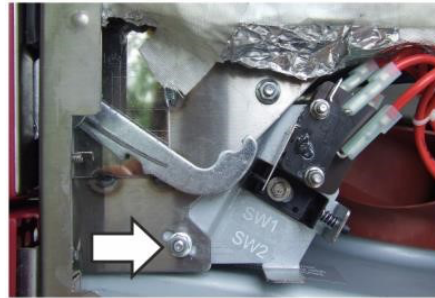

6. Release the adjusting M7 nut and move the backplate until microswitch SW2 just activates (closes). Then tighten both nuts.

7. Remove the spacers, then open and close the appliance door 5-10 times, ensuring the door switches operate correctly.

**IMPORTANT:**

Check if the switches operate in the following sequence as microswitch SW3 must switch the load current.

**Oven door open**

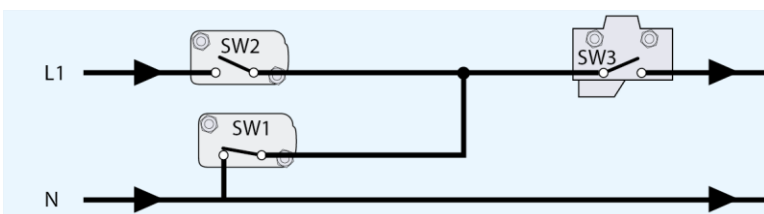

Closing the door:

- SW1 opens first
- SW2 closes second
- SW3 closes third

**Oven door closed**

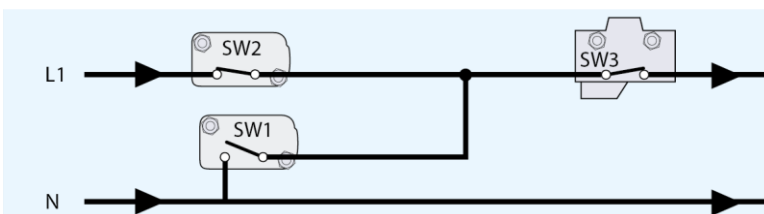

Opening the door:

- SW3 opens first
- SW2 opens second
- SW1 closes third

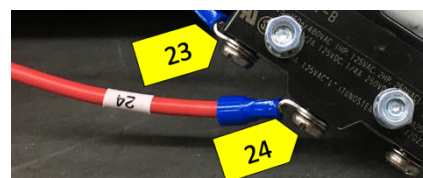
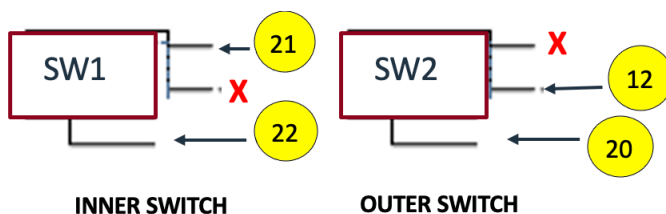

## 6.13 Replacing the stirrer motor and stirrer assembly

### Component



### Requirements

Check that the following requirements have been met:

- The appliance has been disconnected from the power supply and protective measures have been taken to ensure the power cannot be switched on again.
- The appliance is cool.
- The top and side panels of the casing of the appliance have been removed.
- The high voltage capacitors are discharged before commencing work.

### Tools required

M5.5 hex socket wrench

M7 hex socket wrench

Discharge Tool

Pozidriv PZ1 screwdriver

Torque wrench

### Removing the stirrer motor

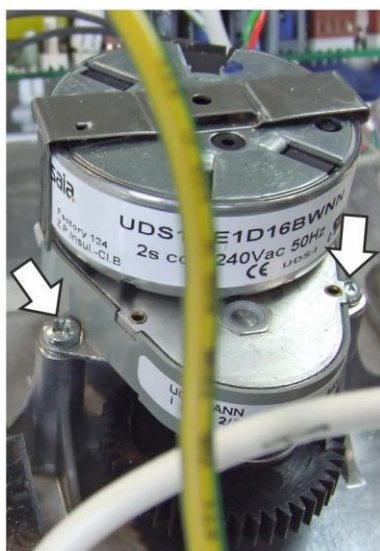

The stirrer motor(s) on top of the cavity can be dismantled using a Pozidriv PZ1 screwdriver. Disconnect electrical connection from loom. Unclip wiring from SRB X20 connection(s).

**NOTE: The threads at the stirrer motor are locked with Loctite.**

### Removing the microwave stirrer



**1.** Loosen the two M7 Hex Screws at the rear and unfasten two M5.5 hex head flange bolts at the front to remove the jet/impinger plate from the roof of the cavity.

NOTE: At the rear the jet/impinger plate rests in a bracket pre September 2020. Post Sept 2020 fixed at front and rear.

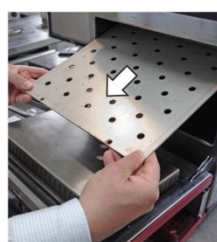
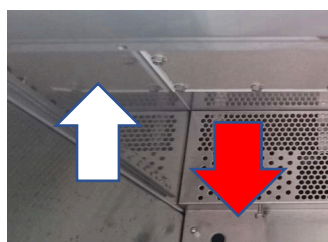

**2.** Remove the jet/impinger plate from the cavity.



**3.** Unfasten sixteen (16) M7 hex nuts.

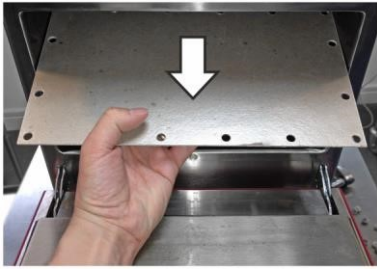

**4.** Remove the partition plate from the cavity.

**NOTE:** The partition plate features a rubber gasket on the side pointing upwards (to the stirrer) when mounted. The rubber gasket prevents grease laden air from soiling the stirrers and needs to be intact at any time.

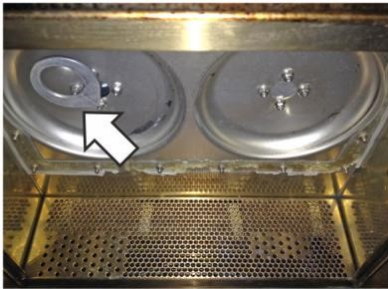
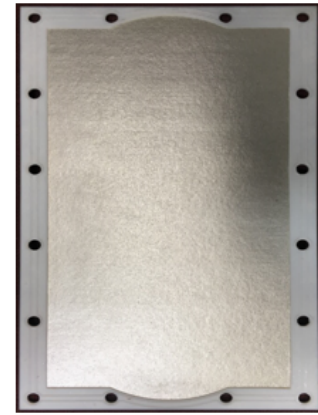

**5.** The image shows the 1000W e2s variant equipped with one stirrer/stirrer motor.

The 2000W e2s variant has a second stirrer/stirrer motor in the right niche.

The stirrer(s) is positioned inside the top of the oven cavity, above the partition plate.

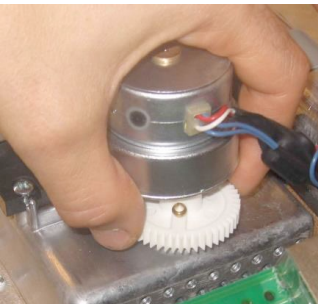

**7.** To remove the stirrer from the spindle, the motor must be prevented from moving. This is most easily achieved by holding the stirrer cog located next to the motor cog.

**8.** The stirrer can then be removed by turning anti-clockwise.

**9.** Remove any remains of the old gasket from the top of the cavity before fitting a new partition plate (comes with gasket) to ensure a good seal.

### ■ Fitting the stirrer motor and assembly

Follow the steps in the reverse order to fit the stirrer motor.

#### ⚠ **IMPORTANT:**

**Follow the steps in the reverse order to fit the stirrer.**

**When refitting the partition plate fasten the screws on opposite corners/sides in turns and do NOT proceed stringently clockwise or anti-clockwise.**

**Tighten the partition plate screws to 2.1 Nm of torque.**

**Tighten the jet/impinger plate screws to NO more than 1.8 Nm of torque.**

## 6.14 Replacing the convection fan motor

### Component



### Requirements

Check that the following requirements have been met:

- The appliance has been disconnected from the power supply and protective measures have been taken to ensure the power cannot be switched on again.
- The appliance is cool.
- All panels of the casing of the appliance have been removed.
- The high voltage capacitors are discharged before commencing work.
- Additional PPE, Mask & Gloves for handling insulation material.

### Tools required

M7 hex socket wrench  
M7 hex spanner  
Torque wrench  
Heat tape  
Discharge Tool  
Stanley / retractable knife

### Removing the convection fan motor

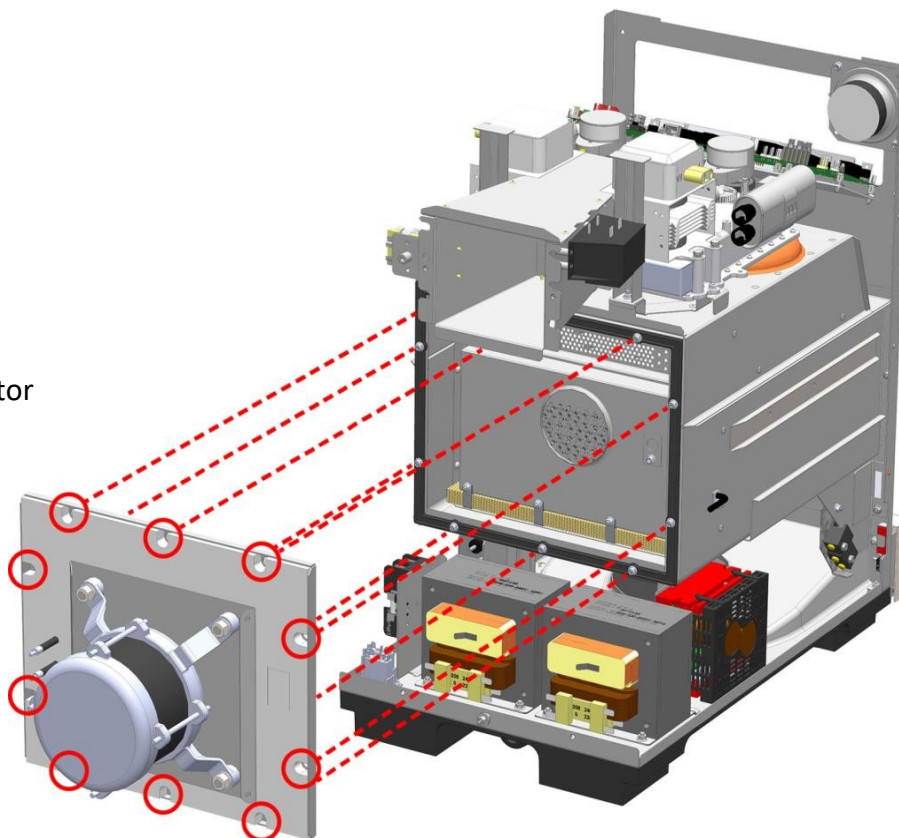
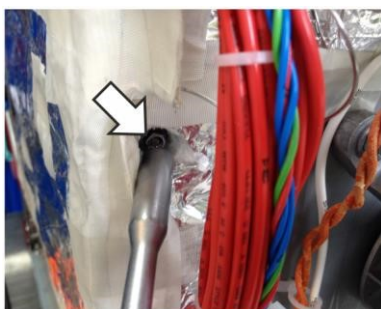

1. Disconnect the convection fan wiring to the safety circuit (grey wires) and the motor speed controller (VFD drive). Disconnect the two heater wires (see section 6.17).

2. Locate the M7 hex nut and remove the steam vent pipe.

3. Locate the ten nuts fixing the plate carrying the convection fan motor to the rear of the cavity. There are three nuts close to the horizontal edges and two nuts close to the vertical edges.

Carefully cut the tape covering the insulation mat with a knife to access the nuts and plate seam.

Unfasten the ten M7 hex nuts to remove the plate with the convection fan motor assembly, being careful of the wiring in the vicinity.

Note: Do not unfasten the four M13 bolts securing the convection fan motor to the plate.

Removing the convection fan motor assembly will also give access to the upper & lower catalytic converters and the heating element.

### ⚠ CAUTION:

**Wear personal protective equipment to protect your fingers when using the knife.**

## ■ Fitting the convection fan motor

Follow the steps in the reverse order to fit the convection fan motor assembly.

On replacement, ensure the rear plate is placed fully over the mounting points on the cavity before refitting and tightening the nuts, fitting new rubber gaskets when refitting the replacement motor assembly and vent pipe, ensuring the mating surfaces are clean.

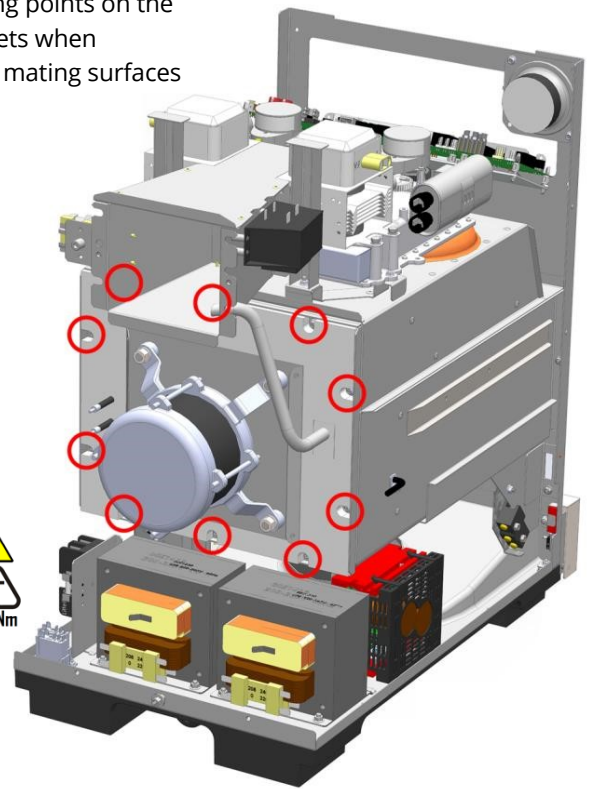
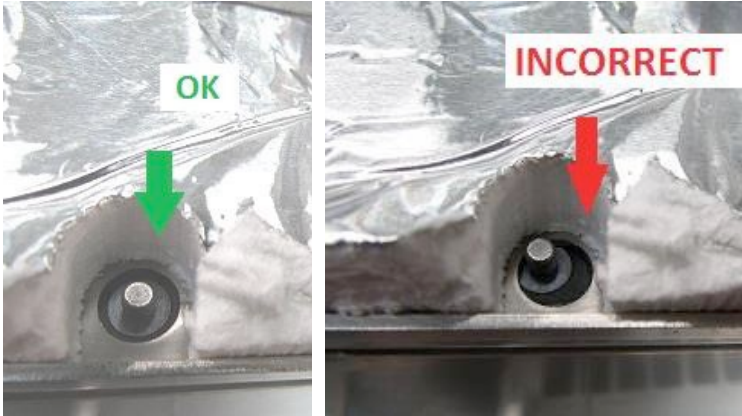

3. Ensure the flange nuts holding the convection motor in place have been torqued to 2.1Nm and are torqued diagonally and not clockwise.

## 6.15 Replacing a transformer (high voltage)

### ■ Component



1000W e2s variant: one high voltage transformer feeding the magnetron.



2000W e2s variant: two high voltage transformers side by side.  
Note: the left hand transformer supplies the right hand microwave circuit

### ■ Tools required

M8 hex socket wrench  
Discharge Tool

## ■ Requirements

Check that the following requirements have been met:

- The appliance has been disconnected from the power supply and protective measures have been taken to ensure the power cannot be switched on again.
- The appliance is cool.
- The casing of the appliance is removed.
- The high voltage capacitors are discharged before commencing work.

## ■ Removing a transformer (high voltage)

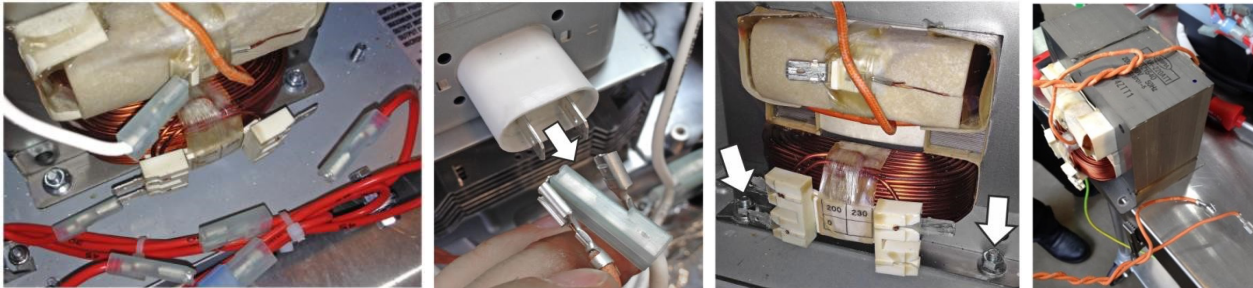

**1.** Unplug all the electrical connections on the transformer(s)

**2.** Disconnect the transformer(s) from the magnetron(s) by unplugging the orange filament cables at the magnetron(s).

**3.** Unfasten the two M8 nuts to remove a transformer.

**⚠ CAUTION:**

**The transformer is heavy. Wear safety shoes to protect your feet from a transformer falling down.**

## ■ Fitting a transformer (high voltage)

Follow the steps in the reverse order to fit the high voltage transformer(s).

### NOTICE:

**It is imperative that the electrical connections are replaced correctly. If the electric connections have not been restored properly this may lead to malfunction/damage of the oven.**

On the 2000W ovens, the HV transformers are wired out of phase with each other, i.e., Neutral to the zero tapping on one HV transformer & Live to the zero tapping of the other HV transformer.

## 6.16 Removing the convection fan motor speed controller

### ■ Component



Remove the convection fan motor speed controller to access the cooling fan located behind it.

### ■ Requirements

Check that the following requirements have been met:

- The appliance has been disconnected from the power supply and protective measures have been taken to ensure the power cannot be switched on again.
- The appliance is cool.
- All casing of the appliance is removed.
- The high voltage capacitors are discharged before commencing work.
- Anti-static precautions have been taken.

### ■ Tools required

M5.5 hex socket wrench

Torque wrench

**Removing/fitting the convection fan motor speed controller**

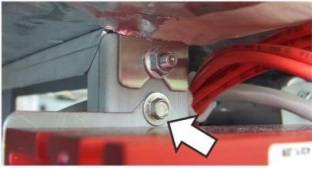

1. Unplug all electric cables connected to the convection fan motor speed controller.
2. Unfasten one M5.5 hex head flange bolt at the top of the bracket to detach the convection fan motor speed controller.

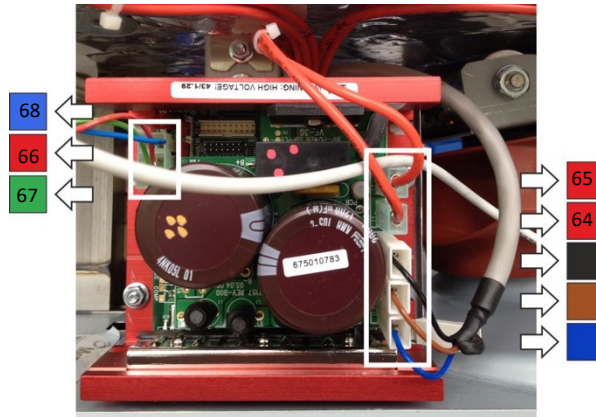

3. Refit in reverse order, refitting the top securing bolt and reconnecting the cables to the convection fan motor speed controller.
- Ensure the wiring of the speed controller is in accordance with the diagram shown left.
- NOTE:**  
**Incorrect wiring can lead to the convection fan motor running in reverse which will cause issues with cooking performance.**

## 6.17 Replacing the heating element

See section 6.14 for convection fan motor assembly removal to access the heating element.

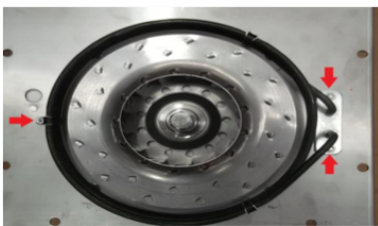

The element is fixed using two M7 hex bolts tightened to 2.1 Nm and supported with a single M5.5 hex flange nut tightened to 1.7 Nm.

Use a 7mm spanner to hold the terminal on the element and loosen the M7 hex nut fixing the wiring connection. Follow the same procedure re-connecting the wiring and tighten to 2 Nm.

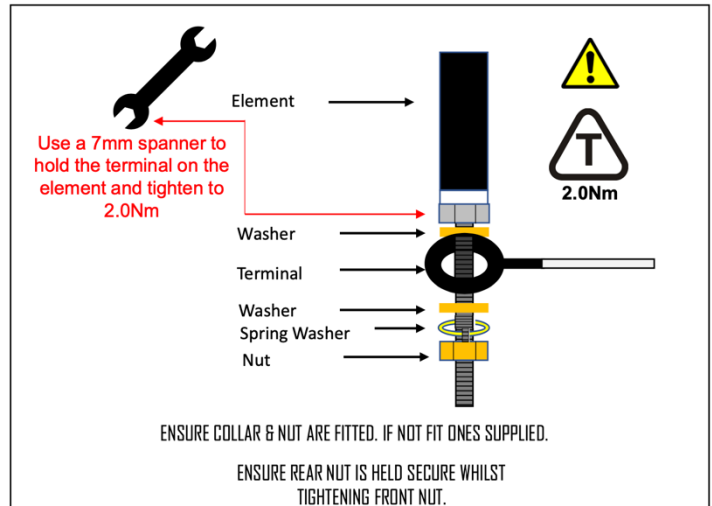
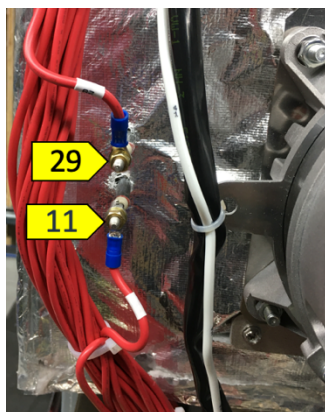



## 6.18 Overview – further components

### Removable diffuser in the cavity

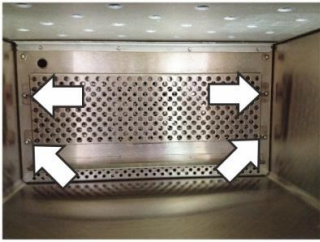

The rear air diffuser plate in the cavity prevents large foodstuff from hitting the rear of the cavity. Loosen the bottom two M7 hex nuts and unfasten the top two M7 hex nuts to remove/refit.

### Protective earth – connections to casing

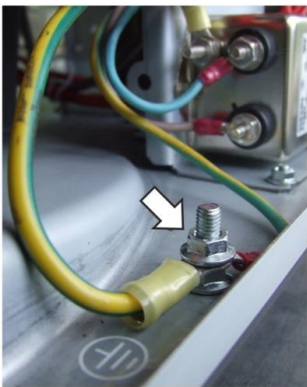

M8 nut

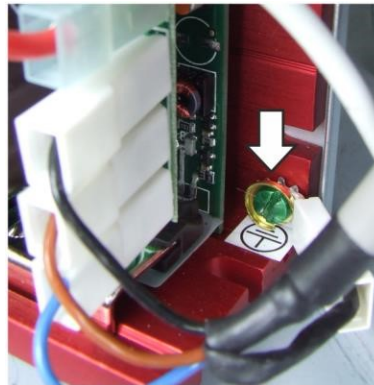

### Cavity high limit



The cavity high limit (cavity overheat thermostat) can be accessed via the rear panel on the left hand side of the grille to manually reset.

Reset procedure:

- Remove the pictured M5.5 hex head flange bolt
- Insert a terminal screwdriver (or similar) into the hole and push in the button to reset.
- After reset, refit the M5.5 hex head flange bolt.

**NOTE: No live terminals are accessible through this port. The panels of the casing do not need to be removed.**

The cavity overheat thermostat is fitted to the cooling duct on the right hand side of the oven, with a single M14 nut and an antivibration rubber grommet on the thermostat side of the bracket. It continually monitors the cavity temperature via a capillary connected to the right hand side of the cavity. Excessive temperature will cause the switch to open and break the safety circuit to the SRB.

The cavity high limit (cavity overheat thermostat) probe is clamped under the cavity wrap insulation on right hand side of the cavity. The two clips are fitted by four M7 hex flange nuts, tightened to 1.7 Nm. On replacement it is imperative that the new probe is located in the same position as pictured.

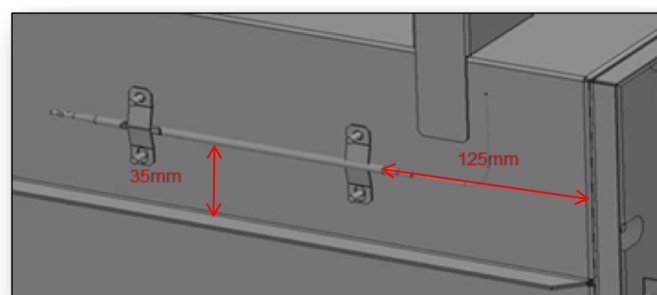
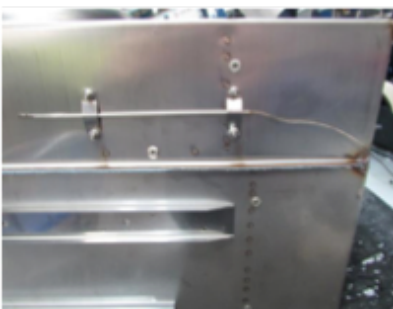

■ Equipotential bonding connection



M8 nut (not fitted to some country specific versions)

■ Electromagnetic Compatibility (EMC) Filters



Two EMC filters fitted, Heater & Microwave\*

Wiring connected by M7 hex nuts

EMC filter to bracket by two M7 hex nuts

EMC filter bracket to base plate by two M7 hex nuts, slotted in at the back.

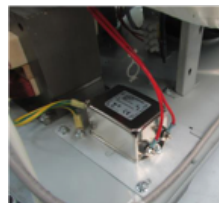

*\* Three filters fitted to JP models. Two on the filter bracket and a third to the left of the HV Transformer for the VFD supply (see wiring diagram in section 7.2 for further information).*

■ Diode(s) (high voltage)

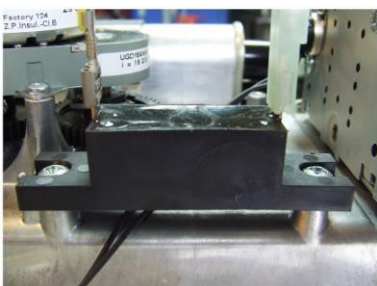

One high voltage diode (1000W e2s variant)

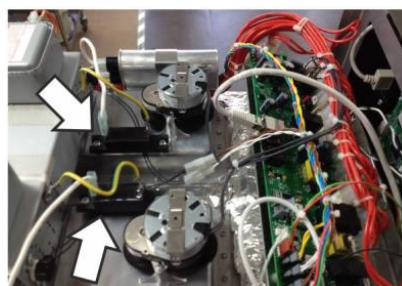

Two high voltage diodes (2000W e2s variant)

Fitted by two pozidriv (PZ2) screws

■ Steam Vent (Exhaust pipe)

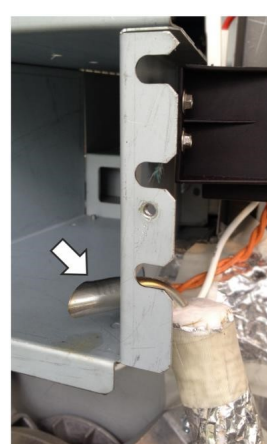

The steam vent exhausts steam from the rear of the cavity to the cooling duct and the rear outlet of the oven. This must be checked for obstruction and cleaned as required.

Fitted to the rear of the cavity with a M7 hex nut.

■ Cavity temperature sensor (thermocouple)

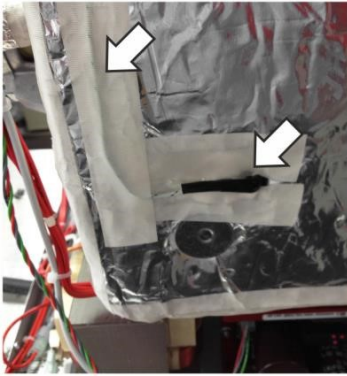

Cavity temperature measuring is done by a temperature sensor (thermocouple) connected to the SRB.

The thermocouple is fitted in the rear of the cavity from the left hand side, sealed with a gasket and held in place by a M7 hex nut.

■ Transformer (low voltage)



The low voltage transformer (ELV) is located on the cooling duct on the left hand side of the oven, fitted by four M5.5 hex head flange bolts

■ Capacitor(s) (high voltage)

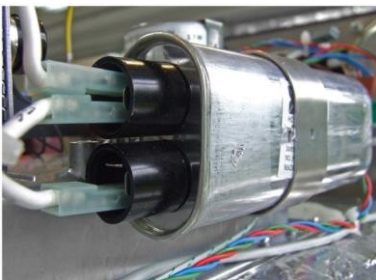

The high voltage capacitor is located on top of the cavity and is fixed by a sheet metal bracket and a pozidriv (PZ2) screw  
 The 2000W e2s variant comprises two high voltage capacitors, again located on the top of the cavity on each side, each attributed to a magnetron.

**LH Magnetron**

Insert HT wire 56 onto piggy back transformer wire

**RH Magnetron**

Insert HT wire 42 onto piggy back transformer wire

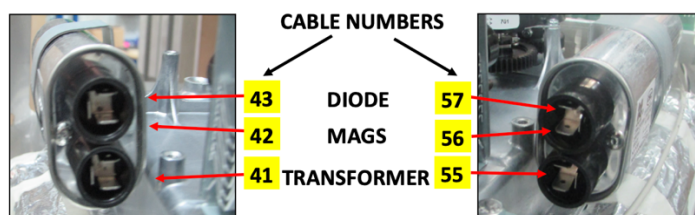

**■ Mains cable entering the interior**



(the mains cable gland is fitted to the cable inlet of the oven at the rear of the oven base)

**■ Catalytic Converters**

See section 6.14 for convection fan motor assembly removal to access the catalytic converters.

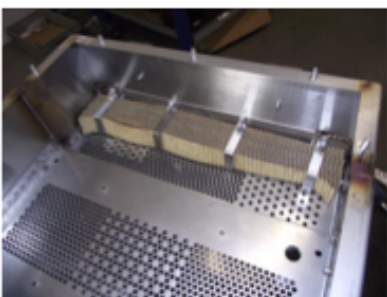

The upper catalyst is fitted using four M7 hex flange nuts, tightened to 2.1 Nm.

Note: remove the storage cable ties before installing a new replacement catalyst.

The lower catalyst, only installed on 2000W models, is again fitted using four M5.5 hex flange nuts, tightened to 2.1 Nm.



**■ Voltage Switching Relay(s)**

The voltage switching relay(s) is located on the rear right hand side of the oven base by two M5.5 hex nuts. The 2000W e2s variant comprises two relays in the same location, one for each HV transformer.

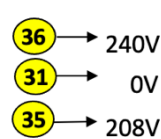
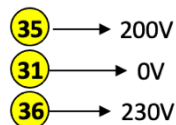
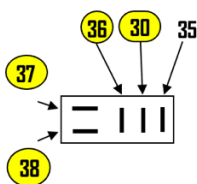
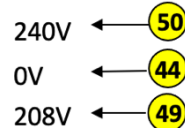
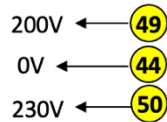
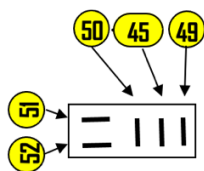
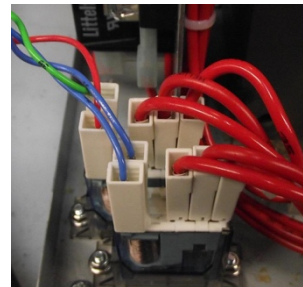

## ■ Air Filter Microswitch

The air filter microswitch is located on the bottom front left hand side of the cavity frame by a M5.5 hex nut and wired directly to the SRB.

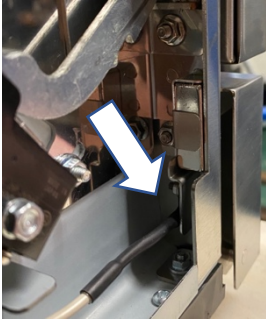

## ■ Speaker

The speaker is located on the top front left hand side of the cavity frame by two M7 hex nuts and wired directly to the QTS.

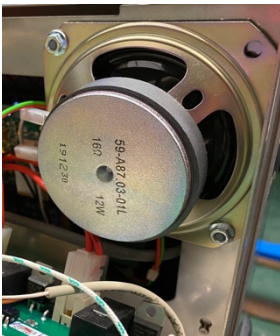

## 6.19 Technical Data Summary Sheet

Fuse Ratings	
F1	20A
F2	20A
F3	13A (*12A)
SRB	1.25A

Overheat Thermostat settings	
Cavity Stat	300°C
Mag Stat	125°C
Fan IP	150°C

Current Draws @ 230VAC	
Heating Element	9 - 10A
Magnetron	7 - 8A

Circuit Breaker Ratings	
e2s 1ph 1000W	D16
e2s 1ph 2000W	D32
e2s 2ph 2000W	D16

Component Resistances	
Voltage Relay Coil	255Ω
EMI Filter L - N	330kΩ*
LV Transformer Pri	81Ω
LV Transformer Sec	1.3Ω
Cooling Fan	205Ω*
Stirrer Motor	7-8Ω
Convection Fan	9Ω ±10%
Heater Element	19Ω

Component Torque Settings (Nm)	
USB Assembly	2.1
Door Switches	1.0
Door Skin	2.1
Door Handle	2.1
Fuse Bracket	2.1
On/Off Switch PCB	1.0
Air Filter Assembly	1.0
Cavity to Base	2.1
Cooling Fan	2.1
Door Choke	2.3
Door Hinges	3.5
Mains Filter Bracket	2.1
Cavity Overheat Thermostat	0.7
Panels	2.1
Partition Plate	2.1
Stirrers	1.0
Impinger Plate	1.2
VDF Bracket	2.8
Waveguides	2.1
Heating Element Wiring	2.0
Mains Filter Wiring	1.2
Magnetron	2.1
Convection Fan Motor Assembly	2.1
Door Switch Bracket	2.8
QTS to panel	0.8
SRB Bracket	2.1
HV Transformer to Base	3.5
Voltage Selection Relay to Base	0.8

Error Codes	
E79	Touch screen released in <15 sec
E80	Touch screen held for >5 sec
E81	Firmware updated
E82	Menu updated
E83	Incompatible SRB version
E84	Date not set
E85	Not used
E86	Oven switched on
E87	Touch screen held for 15 sec
E88	Supply voltage out of range by ±10%
E89	Recommission test failure cooling fan
E90	Recommission test failure convection fan
E91	N/A for e2s - Recommission test failure turntable
E92	Recommission test failure heater <1A
E93	Recommission test failure magnetron(s) <5A
E94	Recommission test failure air filter
E95	Recommission test failure air filter
E96	Recommission test failure door switches
E97	Recommission test failure door switches
E98	Incomplete cleaning cycle, no longer used
E99	Filter override accepted
E100	Mains supply switched on
E101	Magnetron(s) failed on request. <5A.
E102	Heater on without request. >1A
E103	Ambient Overheat. QTS or SRB >70°C
E104	Safety circuit open (Overheat Thermostats)
E105	Supply frequency out of range by ±2%
E106	Cavity 25°C above setpoint

Magnetron	<1Ω
HV Transformer Pri	0.6Ω*
HV Transformer Sec	57Ω*
Capacitor	10MΩ

<b>Maximum Cavity Temperature</b>
275°C

Speaker	2.1
Cavity Thermocouple	1.7
LV Transformer	2.1
Steam Vent Pipe	2.1
Front Panel	2.1
Mains Filter to Bracket	2.8
Fuse Holder	1.0
VDF to Bracket	2.8
Cook Plate Studs	8.0
Heating Element	2.1

E107	Communication fault between QTS & SRB
E108	Missing or corrupt QTS PM
E109	Missing or corrupt SRB PM
E110	Incompatible SRB firmware
E111	Cavity sensor open circuit
E112	SRB temperature sensor failure
E113	Magnetron(s) on without request. >1A
E115	Safety circuit open during microwave cook cycle
E116	Heater off on request. <1A
E117	No longer used, see E115

\* see section 3.1 'Technical data, checks and verification' for non-EU model specific readings where they differ.

## 7 Circuit boards and diagrams

### 7.1 SRB / QTS circuit boards

#### SRB LEDs

- P-Bus – irregular flashing, indicating data communication with QTS.
- Run – Pulsing 1 second flash, indicating that the board has booted up.
- 12V and 5V – lit to show voltage outputs from inboard transformer.
- Relay and triac – lit to show that a signal has been sent to energise that component.
- Door switches – lit to show door closed
- Overheat thermostats – lit to show safety circuit closed

LED positions 

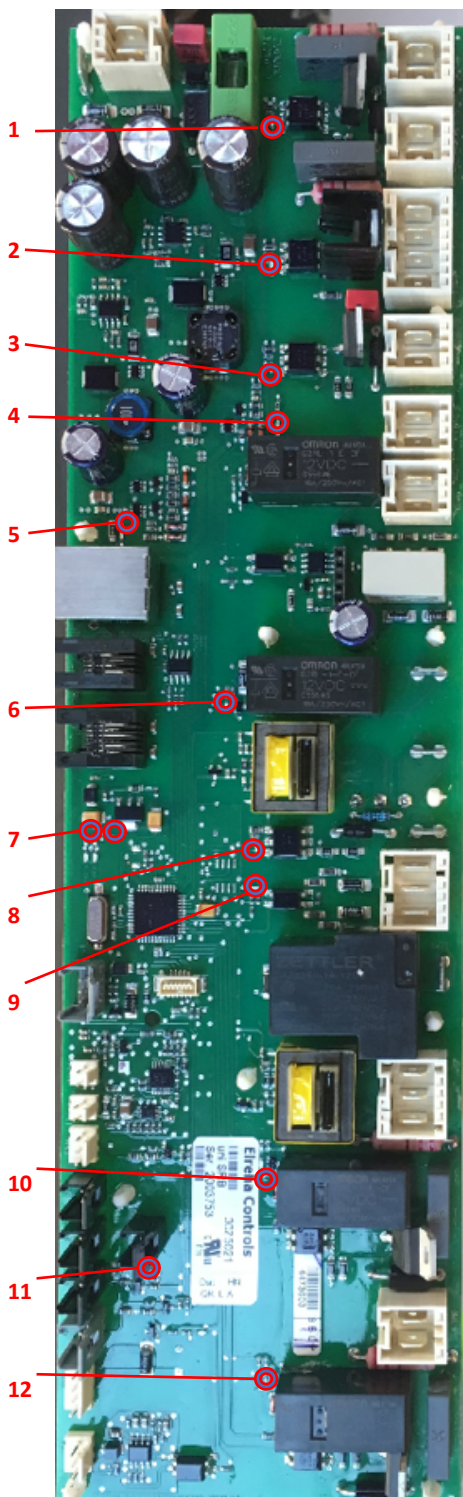

Item	Name
1	Cooling fan. Yellow LED Flashing / Solid at 100% fan speed
2	Convection fan. Yellow LED Dim 10-50%, Bright 60-100% fan speed
3	Stirrer(s). Yellow LED
4	5V supply. Green LED
5	12V supply. Green LED
6	Heater safety. Yellow LED
7	P-Bus: Yellow LED, flashes when data is being sent / received. RUN: Green LED, 1 second flash.
8	Heater drive. Yellow pulsing LED
9	Oven door. Yellow LED
10	RH Microwave drive. Yellow LED
11	Safety circuit. Yellow LED lit to show that a signal is received via overheat thermostats
12	LH Microwave drive. Yellow LED



## SRB terminal locations

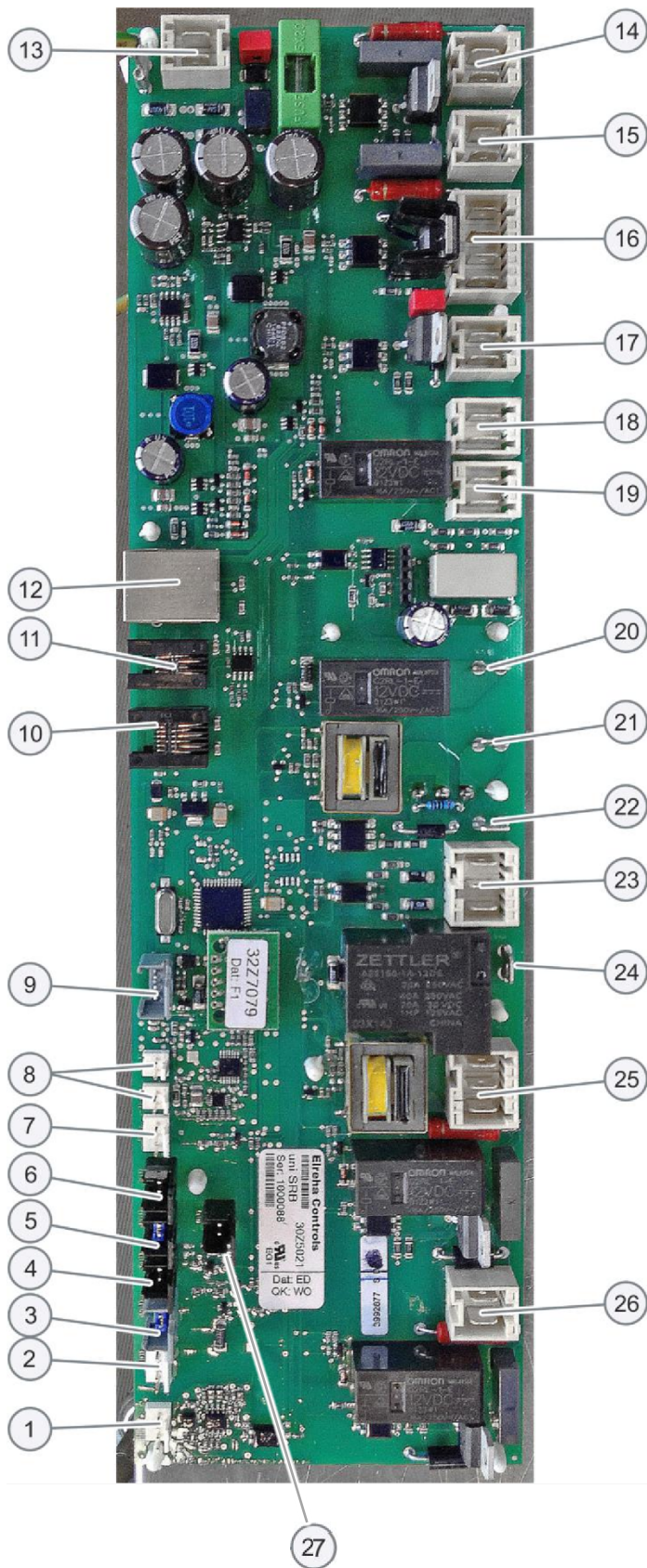

Item	Name
1	X3 - control voltage for convection fan motor speed controller. Wires 66, 67 & 68
2	X101 - voltage selection relay(s) coil feed. Wires 37, 38, 51 & 52. Pins 51 & 52 not used on 1000W ovens
3	X18b - air filter microswitch
4	X18e - left hand magnetron overheat thermostat. Wires 73 & 74
5	X18d - right hand magnetron overheat thermostat. Wires 71 & 72 (shorting link fitted to 1000W ovens)
6	X18c - cavity overheat thermostat & convection fan motor IP. Wires 69 & 70
7	X18a - on-off switch. Wires 25 & 26
8	X14 - not used
8	X14.1 - cavity temperature sensor (thermocouple)
9	X5 - not used
10	X13 - RJ11, P Bus, ethernet port, optional kitchen connect
11	X12 - RJ12, C Bus, development PC port, optional kitchen connect
12	X11 - RJ45, P/C Bus, QTS cable
13	X1 - 24V supply from low voltage transformer. Wires 18 & 19
14	X8 - cooling fan. Wires 58 & 59
15	X17 - not used
16	X20 - microwave stirrer(s). Pins 3 & 4 not used on 1000W ovens
17	X9 - mains output, convection fan controller. Wires 64 & 65
18	X103.1 - mains output, LV transformer. Wires 16 & 17
19	X103 - mains input, live (F3) and neutral. Wires 14 & 15
20	X2.1 - mains input, live (F1) for heaters. Wire 10
21	X2.2 - mains output, live to heaters. Wire 29
22	X102a - mains input, neutral for magnetron transformers and monitor door switch. Wire 13
23	X102b - mains output, neutral to magnetron transformers and monitor door switch. Wires 21, 31 & 45. Wire 45 not used on 1000W ovens
24	X4a - door switch signal from primary door switch (F2 live for magnetron transformers). Wire 24
25	X10 - connector block for door switches. Wires 20, 22 & 23
26	X4b - live for magnetron transformers. Wires 30 & 44. Wire 44 not used on 1000W ovens
27	X18f - not used

## ■ QTS LEDs

- Power – Green LED lit to show that there is a power supply from the SRB.
- Run – Green pulsing 1 second flash, indicating that the board has booted up.
- P-Bus – Yellow LED irregular flashing, indicating data communication with SRB.
- C-Bus – Yellow LED pulsing 0.5 second flash lit to show data being loaded from the Personality Module (PM) onto the QTS. Note: Bus LED operation alters during download and uploading from a USB memory stick.
- LD5 – Yellow LED lit to show the QTS is reading the USB port or that a USB memory stick is fitted.

## ■ QTS terminal & LED locations

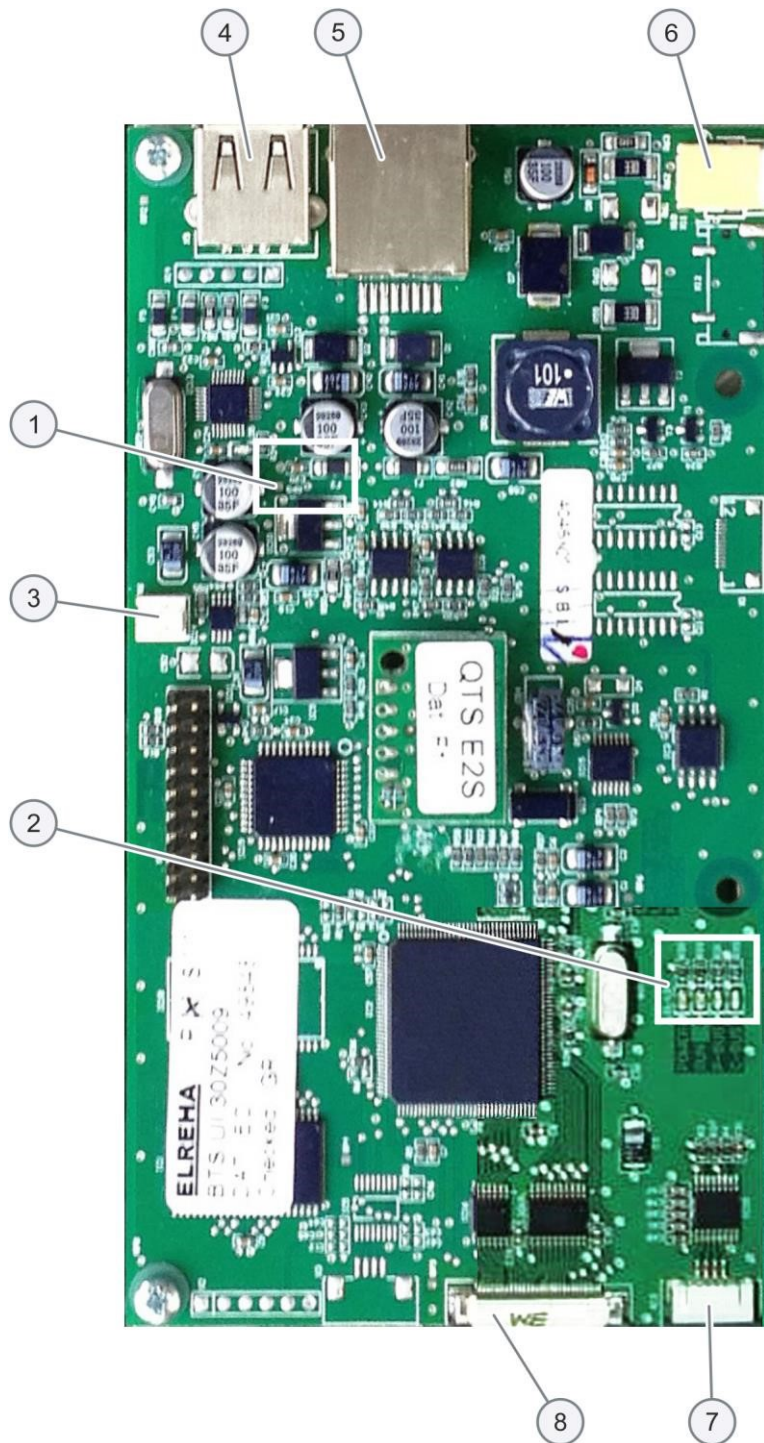

Item	Name
1	LD5 - USB port LED
2	Power, Run, P-Bus, C-Bus LEDs
3	X6 - speaker connection
4	X5 - USB socket / connection
5	X4 - RJ45 communication cable connection to SRB
6	X11 - screen backlight connection
7	X13 - touch pad connection
8	X9 - display screen PCB connection

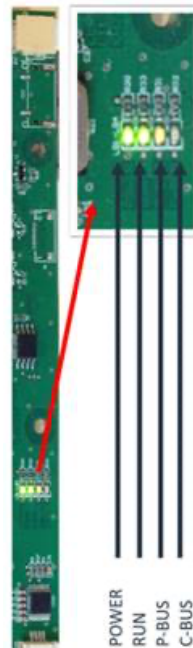

## 7.2 Circuit diagrams

### e2s wiring diagram 50Hz 200/230V

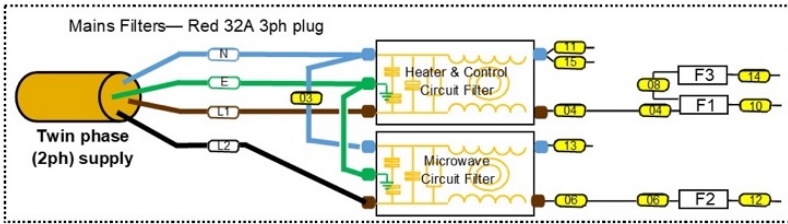
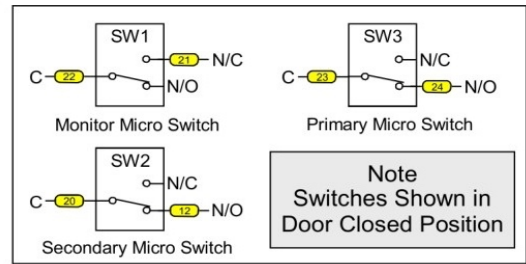
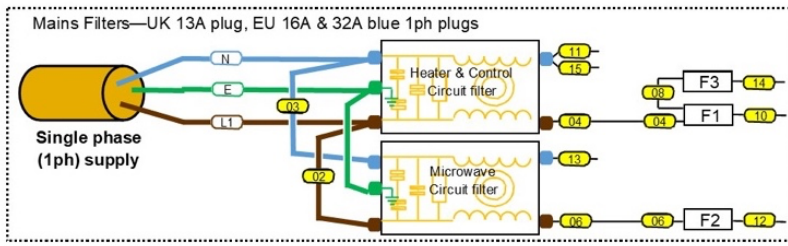

Fuse Rating	
F1	20 Amp
F2	20 Amp
F3	13 Amp

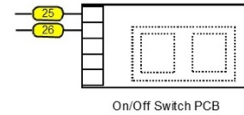

### Door switches - LV safety interlock circuit

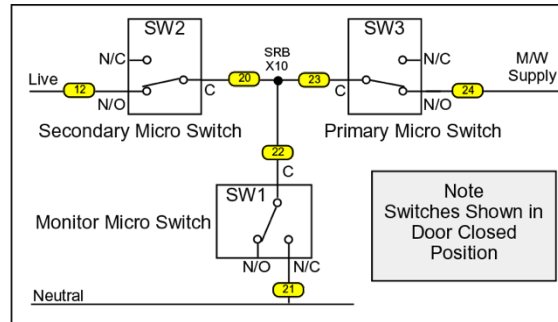

### Overheat thermostats - ELV safety circuit

#### 1000W Ovens

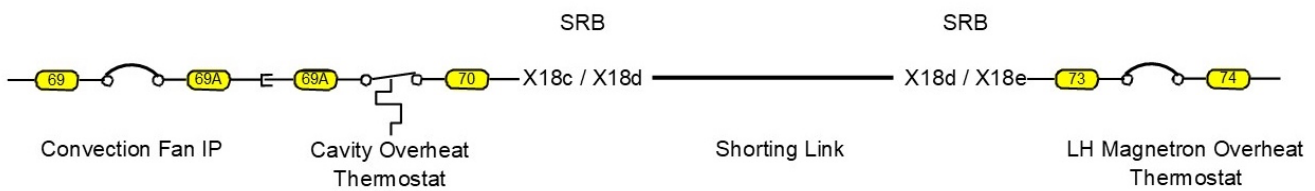

#### 2000W Ovens

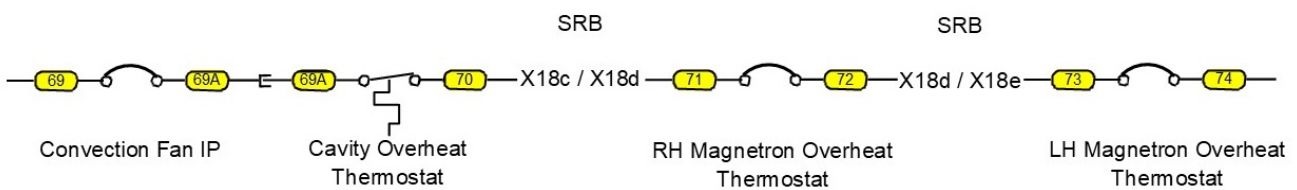

**e2s wiring diagram 50Hz 200/230V continued**

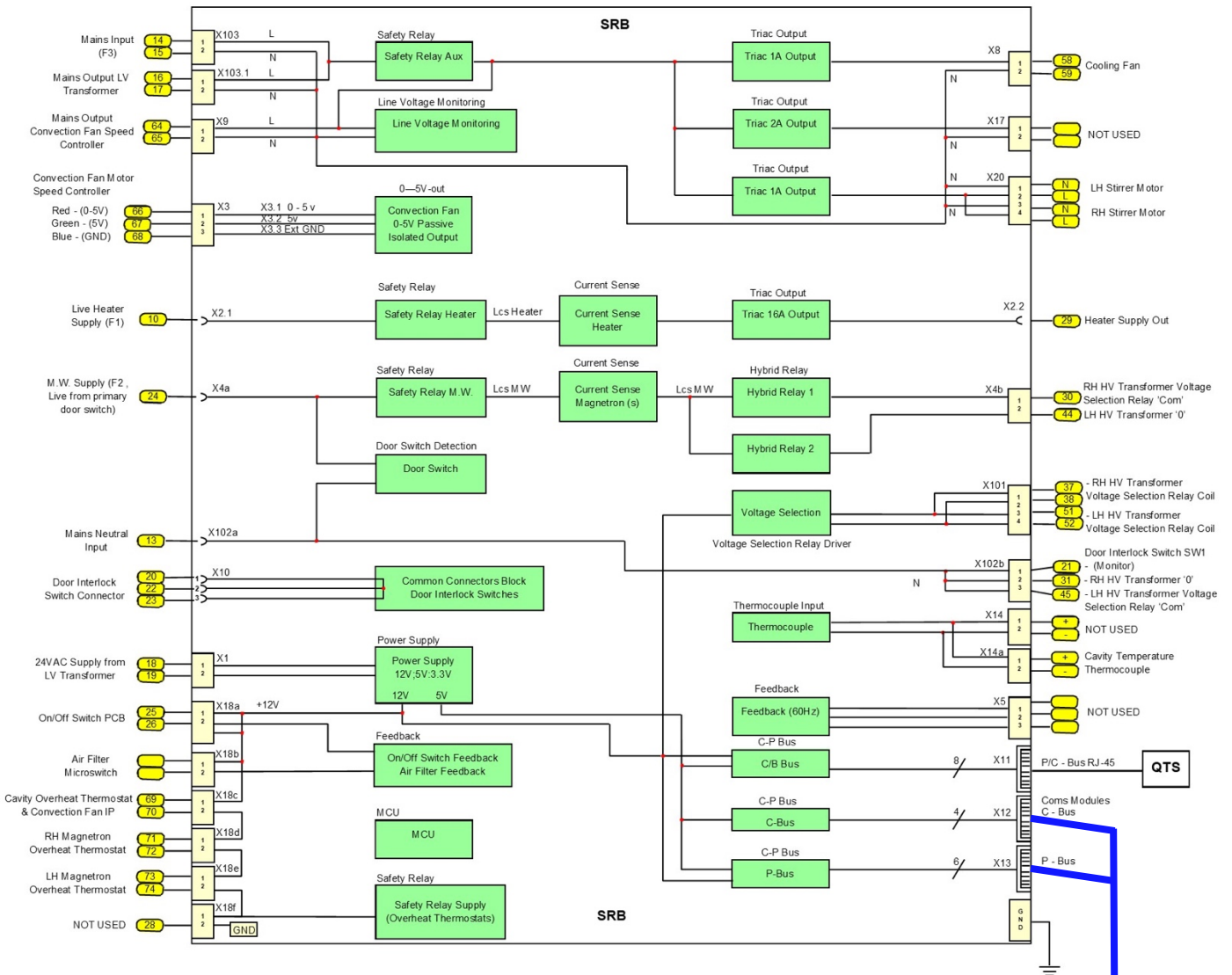

Optional KitchenConnect Communications

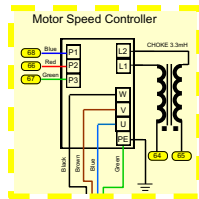

Choke fitted to VFD

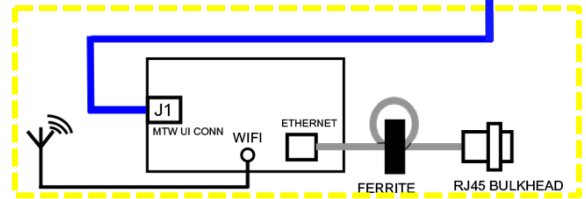

Module & Connections

**e2s wiring diagram 50Hz 200/230V continued**

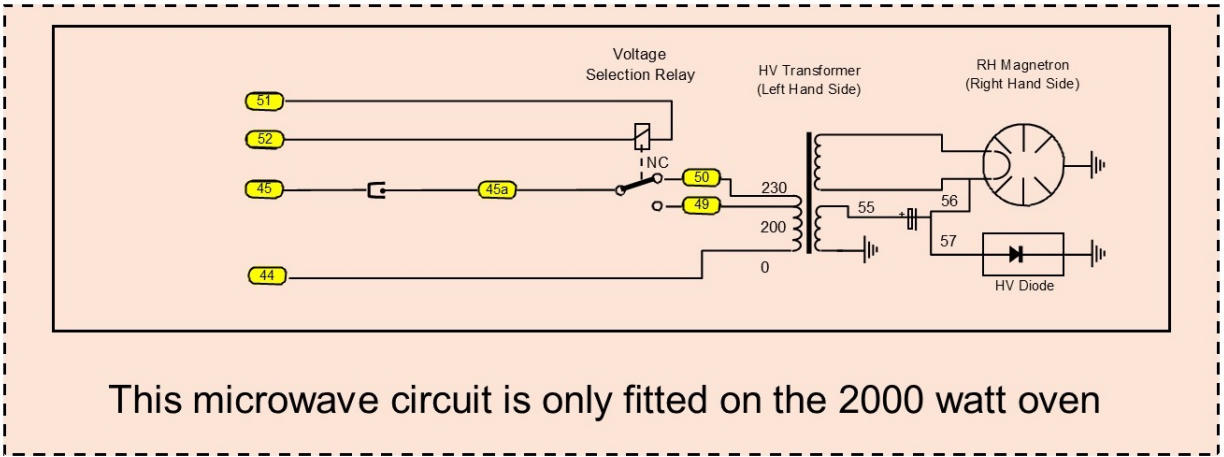
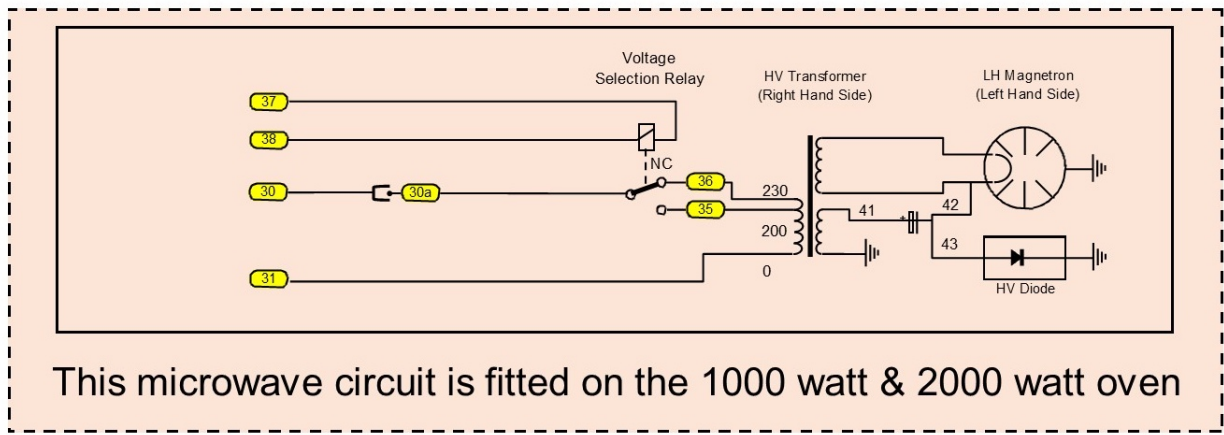
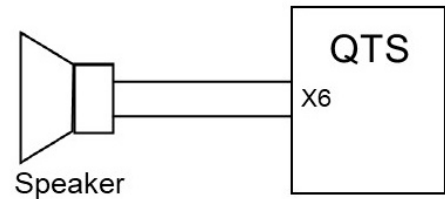
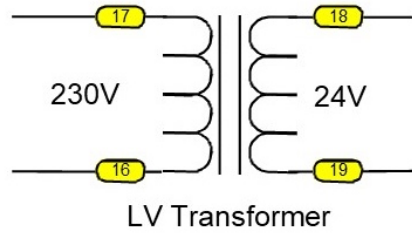
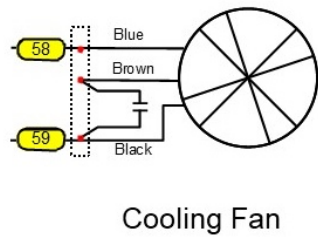
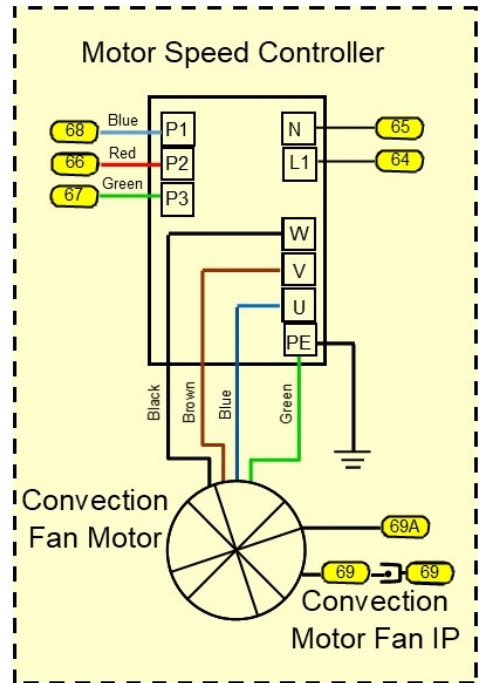
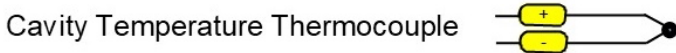
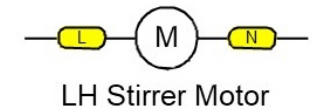
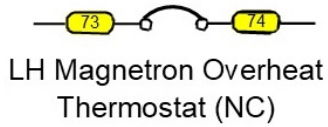
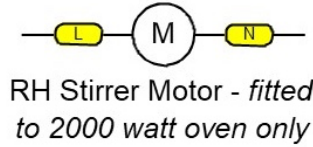
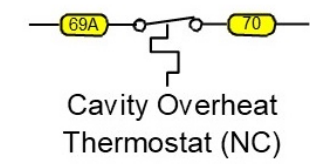

**e2s wiring diagram 60Hz 208/240V**

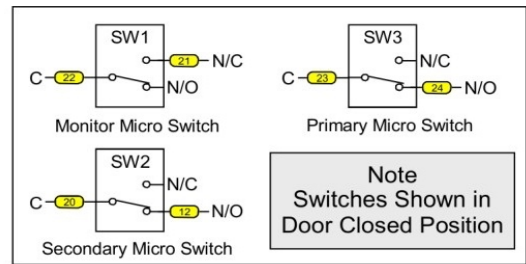
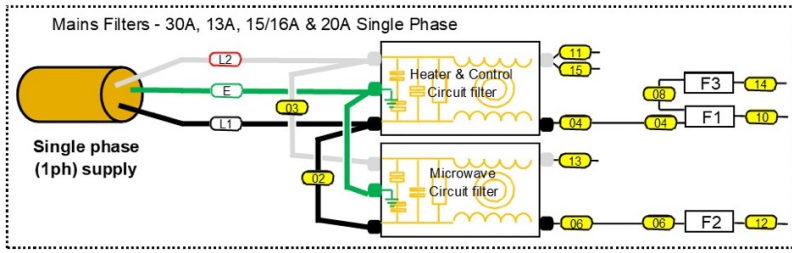

**Door switches - LV safety interlock circuit**

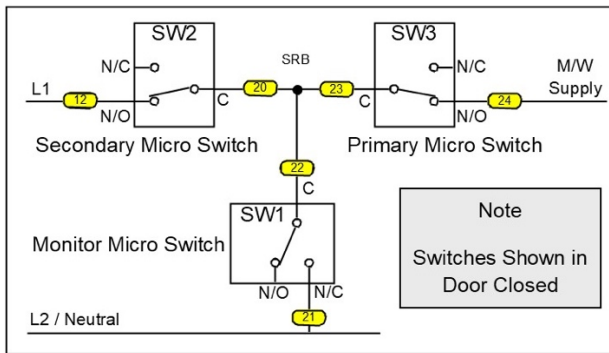

Fuse	
F1	20 Amp
F2	20 Amp
F3	12 Amp

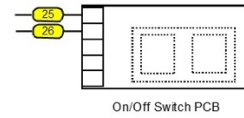

**Overheat thermostats - ELV safety circuit**

1000W Ovens

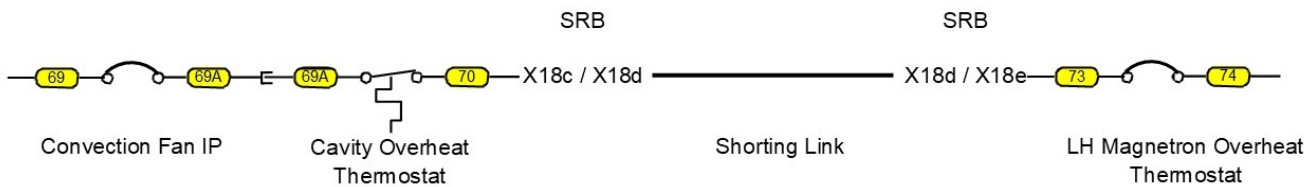

2000W Ovens

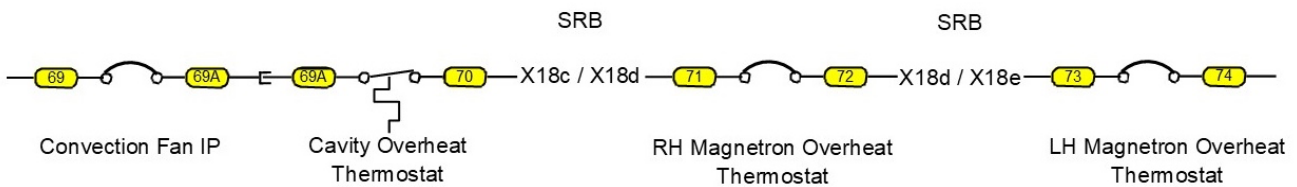

**e2s wiring diagram 60Hz 208/240V continued**

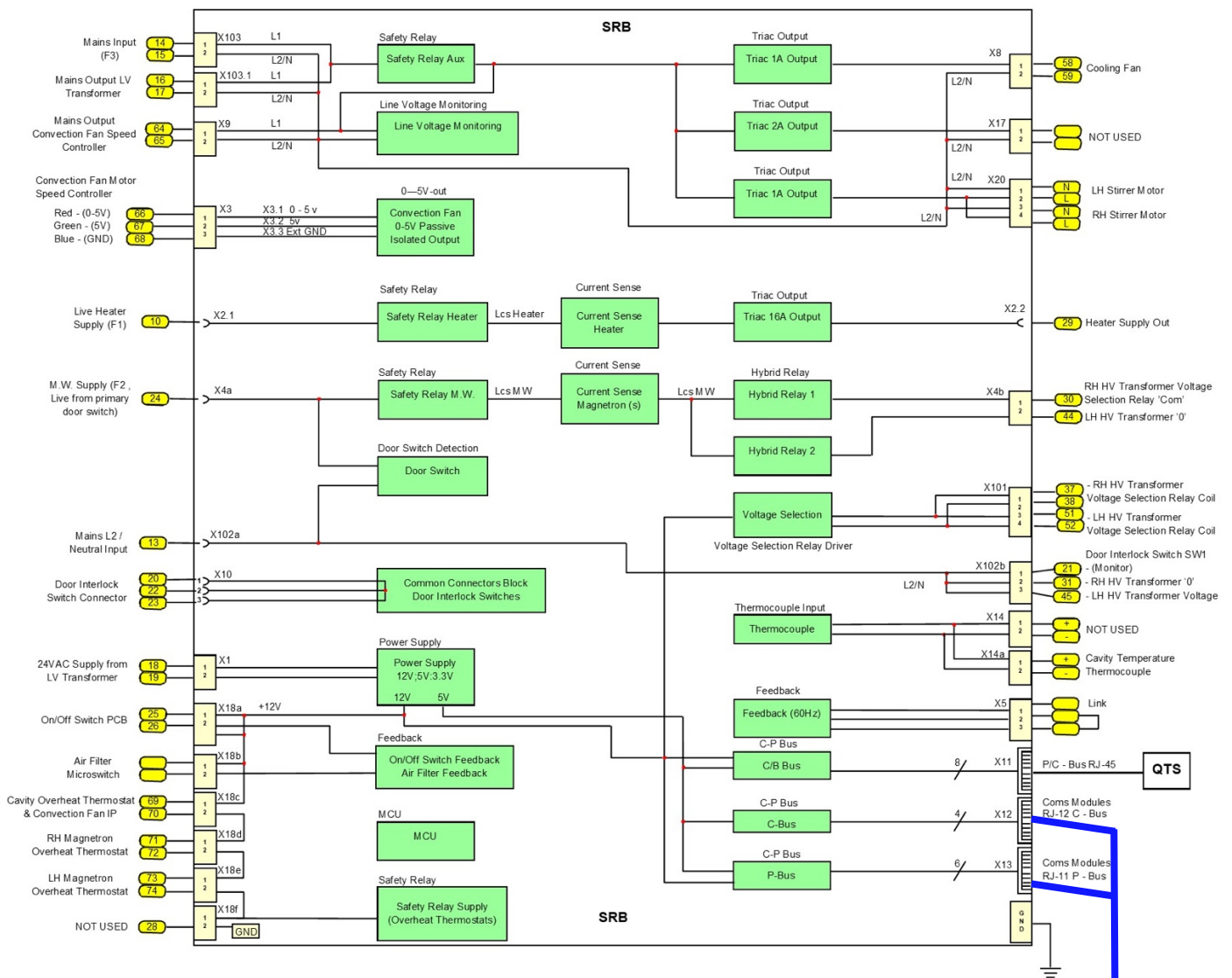

Optional KitchenConnect Communications

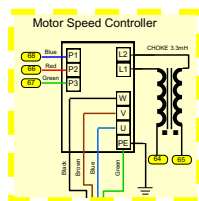

Choke fitted to VFD

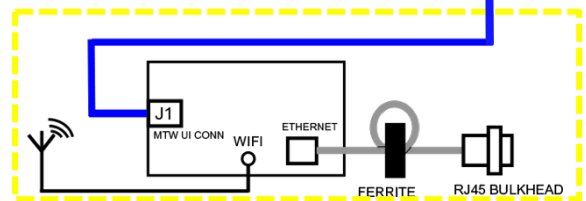

Module & Connections

**e2s wiring diagram 60Hz 208/240V continued**

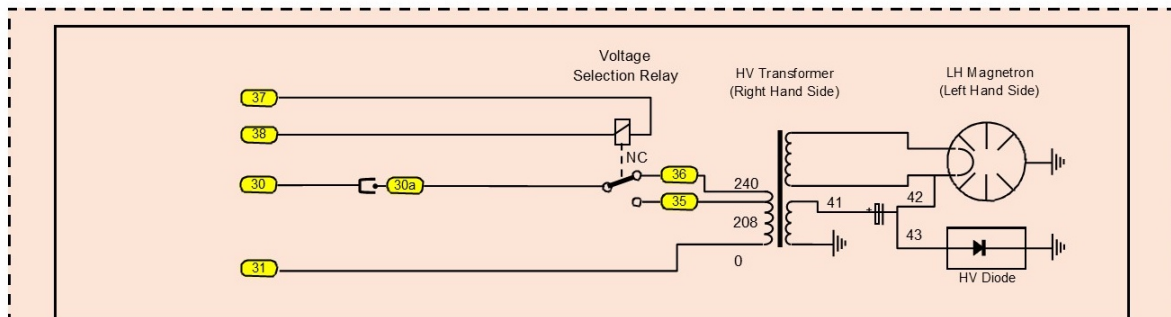
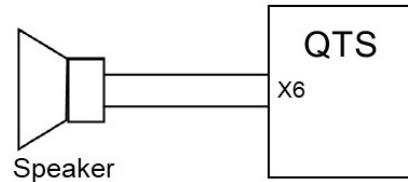
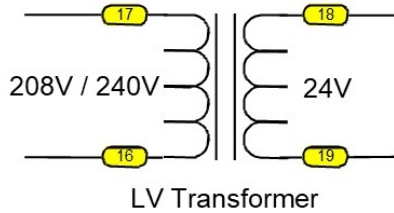
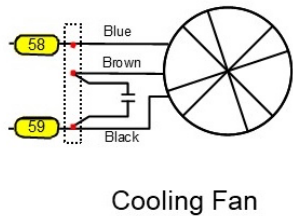
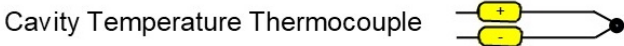
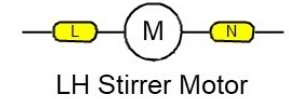
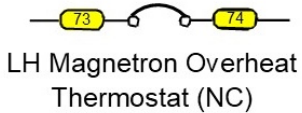
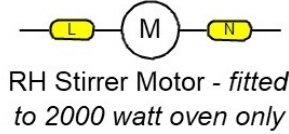
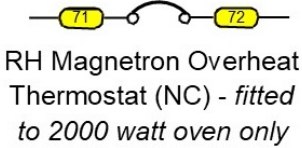
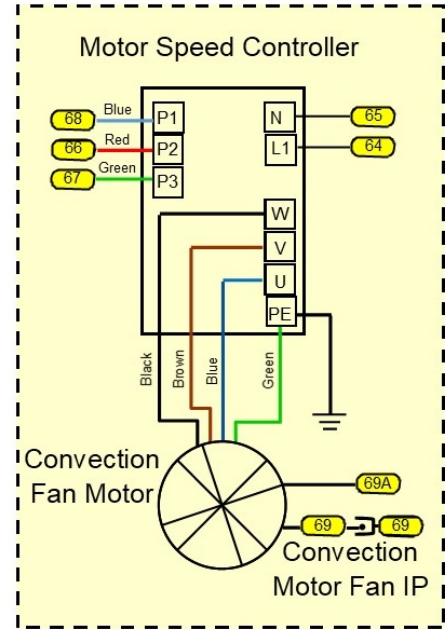
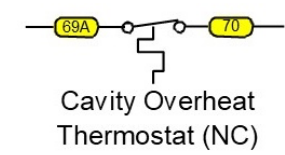

This microwave circuit is fitted on the 1000 watt & 2000 watt oven

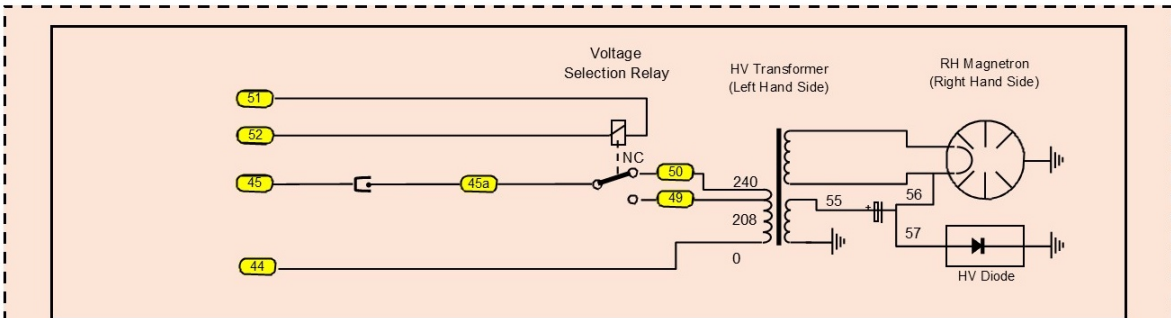

This microwave circuit is only fitted on the 2000 watt oven



**e2s wiring diagram 200V JP Model**

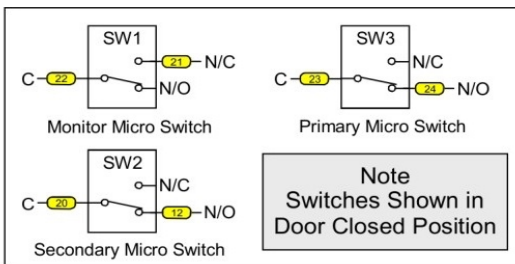
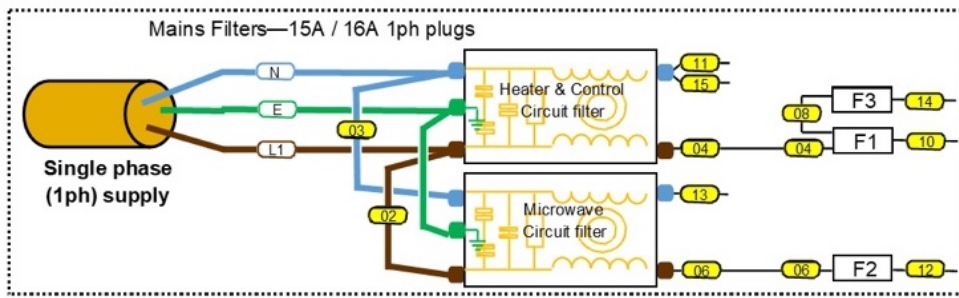

Fuse Rating	
F1	20 Amp
F2	20 Amp
F3	13 Amp

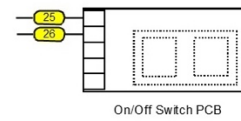

**Door switches - LV safety interlock circuit**

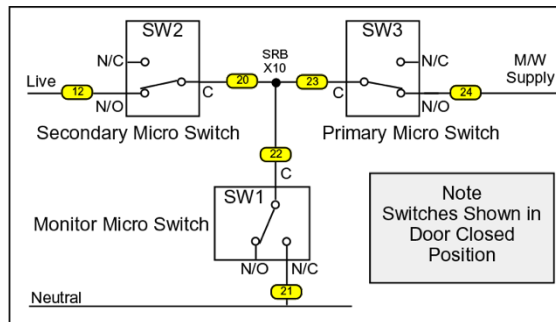

**Overheat thermostats - ELV safety circuit**

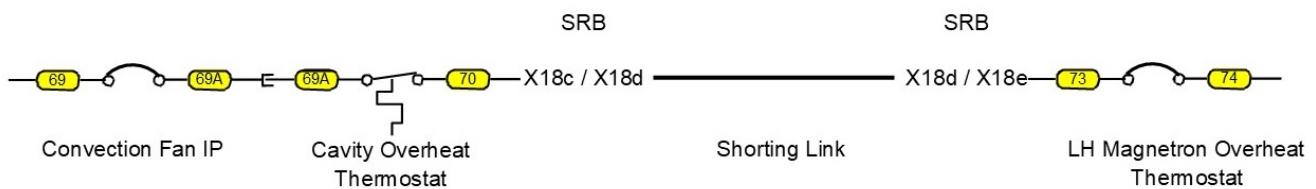

**e2s wiring diagram 200V JP Model continued**

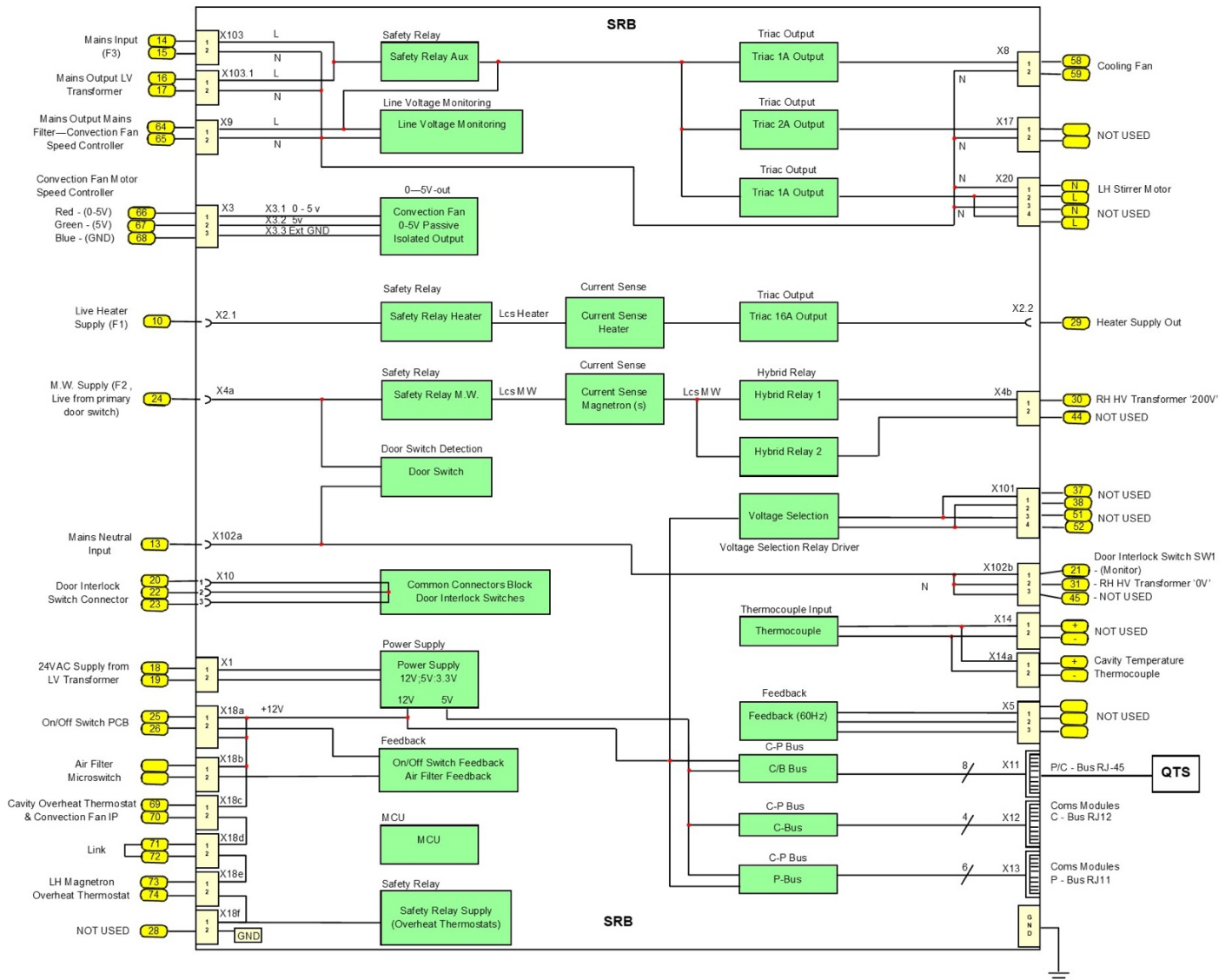

■ e2s wiring diagram 200V JP Model continued

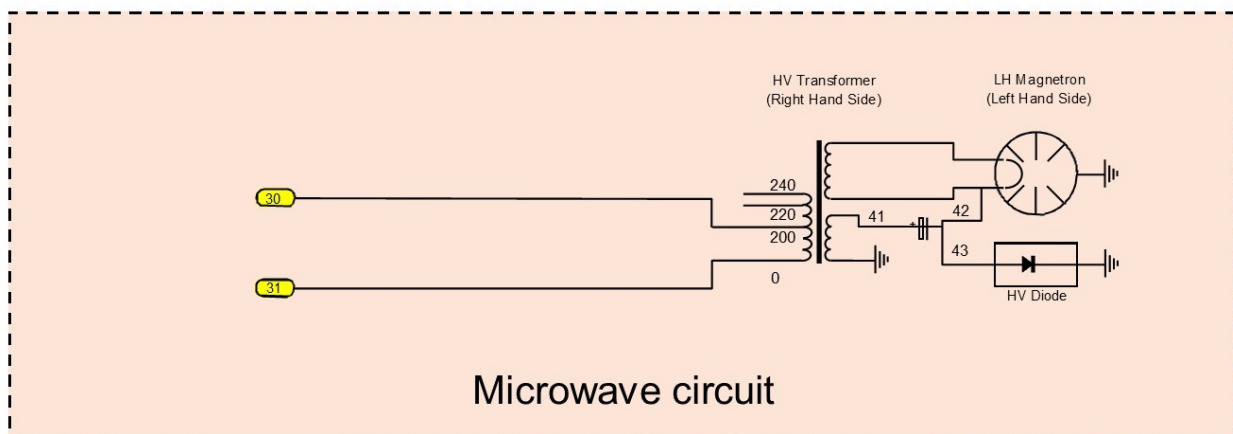
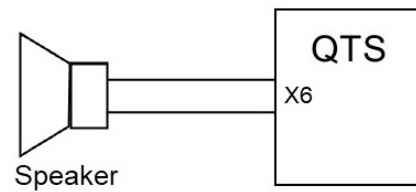
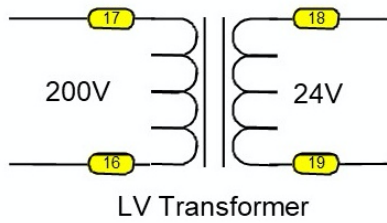
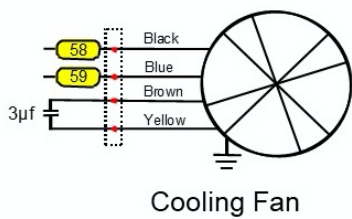
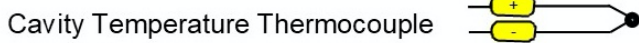
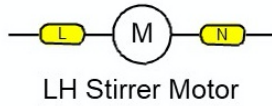
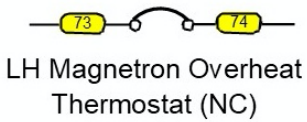
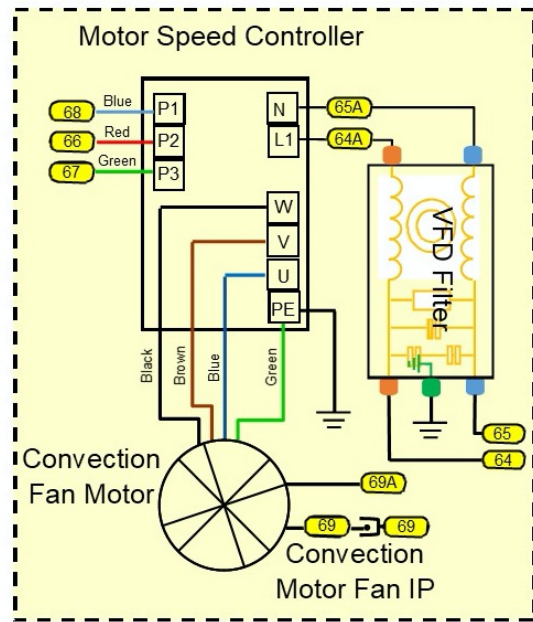
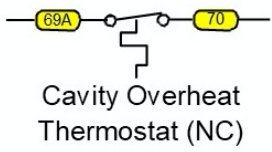

## 8 Annual PM check procedure for eikon® e2s

**Task(s):** Annual Technician PM check

**Frequency:** Annual

**Time to complete:** 1-3 hours

**Model(s):** Merrychef eikon® e2s

**Safety information:**

Please adhere to all Merrychef safety aspects at all times.



Electricity



Manual handling



Hot liquids

### Service procedures

- All tests to be carried out by a trained Merrychef technician.
- Ensure all documented safety procedures are followed for each individual task.
- Refer to the relevant section within this manual for task details.

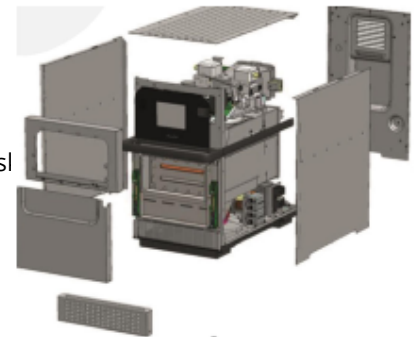

### Task A

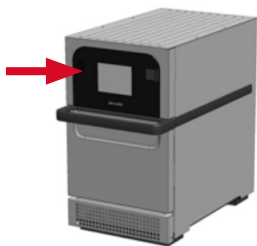

**1.** Check the oven for obvious signs of damage and cleanliness. Switch the oven on and off with front switch, allow to cool down.



**2.** Check the power cord and plug for damage and replace if required.



**3.** Remove the air filter and check for damage, clean and insert or replace if required.

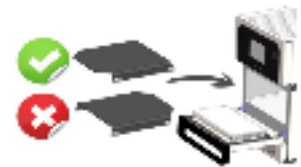

**4.1.** Pre-Jan 2019 Remove old cook plate verify the PTFE feet are intact if not replace with new (angled edge at the front of the cavity).



**4.2.** Post Jan 2019 Remove old cook plate and inspect the scallops (recessed area) for arcing and carbonisation. Replace if worn.



**5.** Inspect the 4 studs for signs of carbon and arching, Remove the side panels and replace as required.



**6.** Check the door seal, ensuring that it is intact, not hanging loose or have any sections broken away or cracked. Replace if required and allow silicone to cure.



**7.** Remove & refit upper impinger plate inspecting for cleanliness and signs of damage (if required follow the instructions laid out in the replacement impinger Kit). Visually check the partition plate for signs of discolouration or damage.

**Task B**



**8.** Switch the oven on and record the Serial Number. Check the firmware is correct, update if older version is observed.

Press the top right-hand corner of the screen to access the key



**9.** Enter the password **MANAGER** to access the settings menu. Use the displayed oven serial number this is invalid.

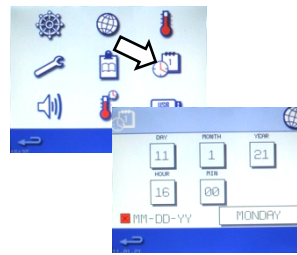

**10.** Check the date, day and time, correct if necessary. Refer to Installation and User manual for details on the procedure

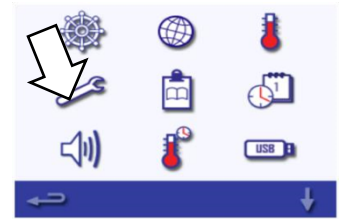

**11.** Press the spanner symbol and enter the password **SERVICE** to access the service screen. Use the displayed oven serial number this is invalid.

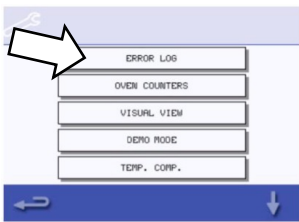

**12.** Check the "Error Log" for details of any logged appliance errors. Refer to the fault finding section 5.3 to reference any errors logged.

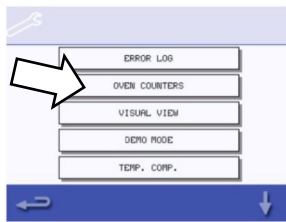

**13.** Select the oven counters and reference the service check sheet for recommended replacements, advise the customer on actions required.

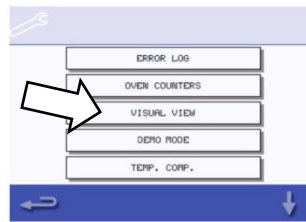

**14.** Select the visual view to perform individual component checks.

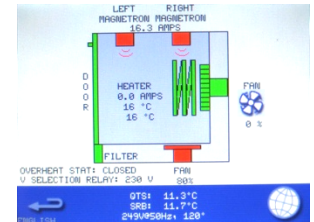

**15.** In visual view select/operate each component to check operation, as detailed in the visual view section 5.2. Check all speed ranges of the fans. Record microwave (individual & combined) and heater current draws. Record displayed Voltage

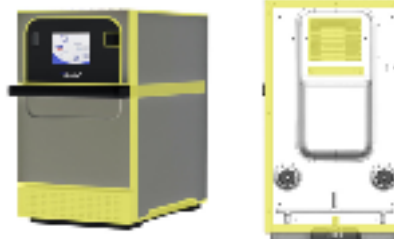
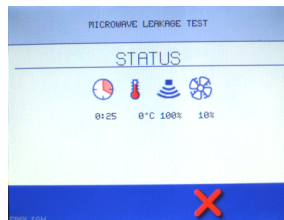
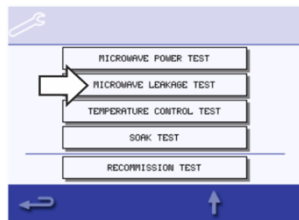

Note: ensure a bowl of cold water is in the cavity for the microwave current draw checks.

**16.** Exit out of visual view, place a bowl with 275 ml of cold water in the cavity and select Microwave Leakage test. While the test is running hold the test probe at right angles to the oven, ensuring the sensor is about 50mm away from the surface. Test the following areas marked in yellow, refer to section 5.6 for further details. Level must be 5mW/cm2 or lower & record.

**17.** Finally, remove the bowl of water from inside the cavity and select the recommission test (if the recommission test is greyed out, it means the oven is above the desired temperature and the function is disabled). Follow the onscreen instructions and record result.

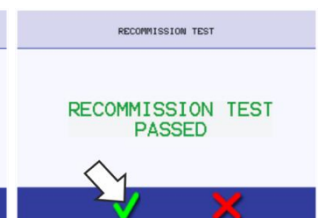
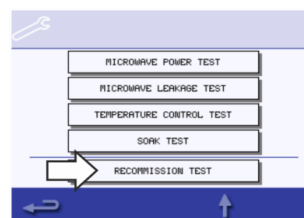

**18.** Come out of the service and setting modes. Pre-heat the oven and cook one item of food from the operators' menu.

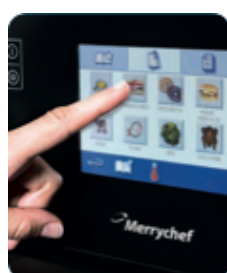

Planned preventative maintenance schedule for the Merrychef eikon® e2s commercial combination oven			Daily	12 months	24 months	48 months	Comments
Item	Description	Commissioning	Operator	OCIE check			See latest parts manual for part numbers
1	Check installation and surroundings as per installation instructions	✓	✓	✓	✓	✓	
2	Check cook baskets for damage and replace if required.	✓	✓	✓	✓	✓	For operator to check
3	Check oven cook plate		✓	✓	✓	✓	If damaged replace cook plate and studs
4	Check air filter and clean	✓	✓	✓	✓	✓	Oven can be damaged if missing
5	Inspect impinger plate, replace as required			✓	✓	✓	Replace every 24 Months or when damaged
6	Inspect partition plate			✓	✓	✓	Replace if damaged
7	Visually check oven for damage			✓	✓	✓	Document findings
8	Check condition of mains lead and plug			✓	✓	✓	Replace mains lead if damaged. Check oven model for service part number.
9	Clean oven as per user instructions		✓				
10	Check and clean steam vent pipe			✓	✓	✓	
11	Check door seal condition and replace as required		✓	✓	✓	✓	Replace every 24 Months or when damaged
12	Check door operation	✓	✓	✓	✓	✓	
13	Check on/off switch operation		✓	✓	✓	✓	
14	Check oven serial number & firmware revisions	✓		✓	✓	✓	Update firmware is older version(s) displayed
15	Check touch screen condition and operation		✓	✓	✓	✓	Calibrate if required
16	Check touch screen overlay and replace as required			✓	✓	✓	Replace every 24 Months or when damaged
17	Check date & time	✓		✓	✓	✓	Update as required
18	Check and record oven counter screen			✓	✓	✓	
19	Check & record amp draw, heating element and magnetron(s)			✓	✓	✓	
20	Check operation oven components			✓	✓	✓	
21	Check stirrer motor(s) is rotating			✓	✓	✓	Listen with all other components switched off
22	Check oven temperature calibration	✓		✓	✓	✓	Check cavity temperature is in range
23	Unplug and isolate (LOTO)			✓	✓	✓	
24	Remove all panels and discharge the HV Capacitor(s)			✓	✓	✓	
25	Check all internal electrical connections for tightness and condition			✓	✓	✓	
26	Check magnetron(s) and cooling duct			✓	✓	✓	Replace magnetron(s) every 48 months or every 1500 Mag Hours
27	Check door switch condition and adjustment			✓	✓	✓	Replace 24 Months or when damaged
28	Vacuum out casework			✓	✓	✓	
29	Refit all panels and plug the unit in to the electrical supply. Switch the oven on			✓	✓	✓	
30	Check & download error log file			✓	✓	✓	
31	Download cook count file			✓	✓	✓	
32	Check for microwave leakage	✓		✓	✓	✓	
33	Complete recommission test and service report	✓		✓	✓	✓	
34	Pre-heat the oven and cook one item of food from the operators' menu.	✓	✓	✓	✓	✓	
Total hrs/mins			0.5hrs	1hr	2hrs	3hrs	

= Mandatory checks that can be completed in visual view and should only take 15min to attend to and record findings in the comments column

= Mandatory

= Optional outside of PM requirement

Microwave Combination Oven

Merrychef eikon<sup>®</sup> e2s

Part Number 32Z3935



Welbilt offers fully-integrated kitchen systems and our products are backed by KitchenCare<sup>®</sup> aftermarket parts and service. Welbilt's portfolio of award-winning brands includes **Cleveland<sup>™</sup>**, **Convotherm<sup>®</sup>**, **Crem<sup>®</sup>**, **Delfield<sup>®</sup>**, **fitkitchen<sup>®</sup>**, **Frymaster<sup>®</sup>**, **Garland<sup>®</sup>**, **Kolpak<sup>®</sup>**, **Lincoln<sup>®</sup>**, **Manitowoc<sup>®</sup>**, **Merco<sup>®</sup>**, **Merrychef<sup>®</sup>** and **Multiplex<sup>®</sup>**.

*Bringing innovation to the table* • **welbilt.com**