



IMPORTANT FOR FUTURE REFERENCE
 Please complete this information and retain this manual for the life of the equipment:

Model #: _____
 Serial #: _____
 Date Purchased: _____

INSTALLATION & OPERATION MANUAL

Electric Power Tilt Skillets ELTS-30 ELTS-40

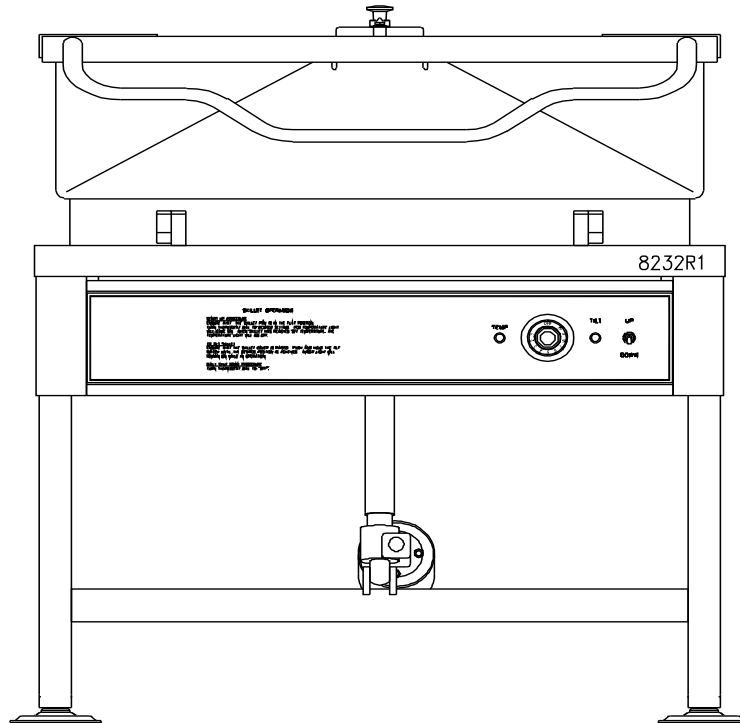

⚠ WARNING

Improper installation, adjustment, alteration, service or maintenance can cause property damage, injury or death. Read the installation, operating and maintenance instructions thoroughly before installing or servicing this equipment.

CROWN FOOD SERVICE EQUIPMENT

 A Middleby Company

70 Oakdale Road, Downsview (Toronto) Ontario, Canada, M3N 1V9
 Telephone: 919-762-1000 www.crownsteamgroup.com

Printed in Canada



1.0 IMPORTANT NOTES FOR INSTALLATION AND OPERATION



This is the safety alert symbol. It is used to alert you to potential personal injury hazards. Obey all safety messages that follow this symbol to avoid possible injury or death.

Do not attempt to operate this unit in the event of a power failure.

Adequate clearances must be maintained for servicing and proper operation.



WARNING: Improper installation, operation, adjustment, alteration, service or maintenance can cause property damage, injury or death. Read the installation, operating and maintenance instructions thoroughly before installing, operating or servicing this equipment.

This manual should be retained for future reference.

Intended for commercial use only. Not for household use.

INSTALLATION AND OPERATION MANUAL, ELECTRIC POWER TILT SKILLETS, ELTS-30,
ELTS-40

TABLE OF CONTENTS

DESCRIPTION	PAGE
1.0 Important Notes for Installation and Operation	2
2.0 Service Connections	4
3.0 Installation Instructions	5
4.0 Operation Instructions.	8
5.0 Cleaning Instructions	10
6.0 Cooking Guidelines	11
7.0 Maintenance	16
8.0 Troubleshooting	17

INSTALLATION AND OPERATION MANUAL, ELECTRIC POWER TILT SKILLETS, ELTS-30, ELTS-40

2.0 SERVICE CONNECTIONS

- ⚡ – Single electrical connection required for 208, 240 or 480 volt, single or three phase 60Hz. with ground wire. A separate 120V connection or step down transformer is required for 380V, 415V or 480V.
- 💧 – COLD WATER: 3/8" O.D. tubing to faucet (OPTIONAL)
- 🔥 – HOT WATER: 3/8" O.D. tubing to faucet (OPTIONAL)

Available kW			AMPS PER LINE							
MODEL	STD.	OPT.	kW	PHASE	208V	220V	240V	380V	415V	480V
ELTS-30	12	N/A	12	1	57.7	54.5	50.0	N/A	N/A	N/A
				3	33.3	31.5	28.9	18.2	16.7	14.4
ELTS-40	15	18	15	1	72.1	68.2	62.5	N/A	N/A	N/A
				3	41.6	39.4	36.1	22.8	20.9	18.0
			18	1	86.5	81.8	75.0	N/A	N/A	N/A
				3	50.0	47.2	43.3	27.3	25.0	21.7

DIMENSIONS

MODEL	CAPACITY		A	B	C
ELTS-30	30 gallons	inches	36.0	33.5	74
	114 litres	mm	914	851	1880
ELTS-40	40 gallons	inches	48.0	45.5	74
	152 litres	mm	1219	1156	1880

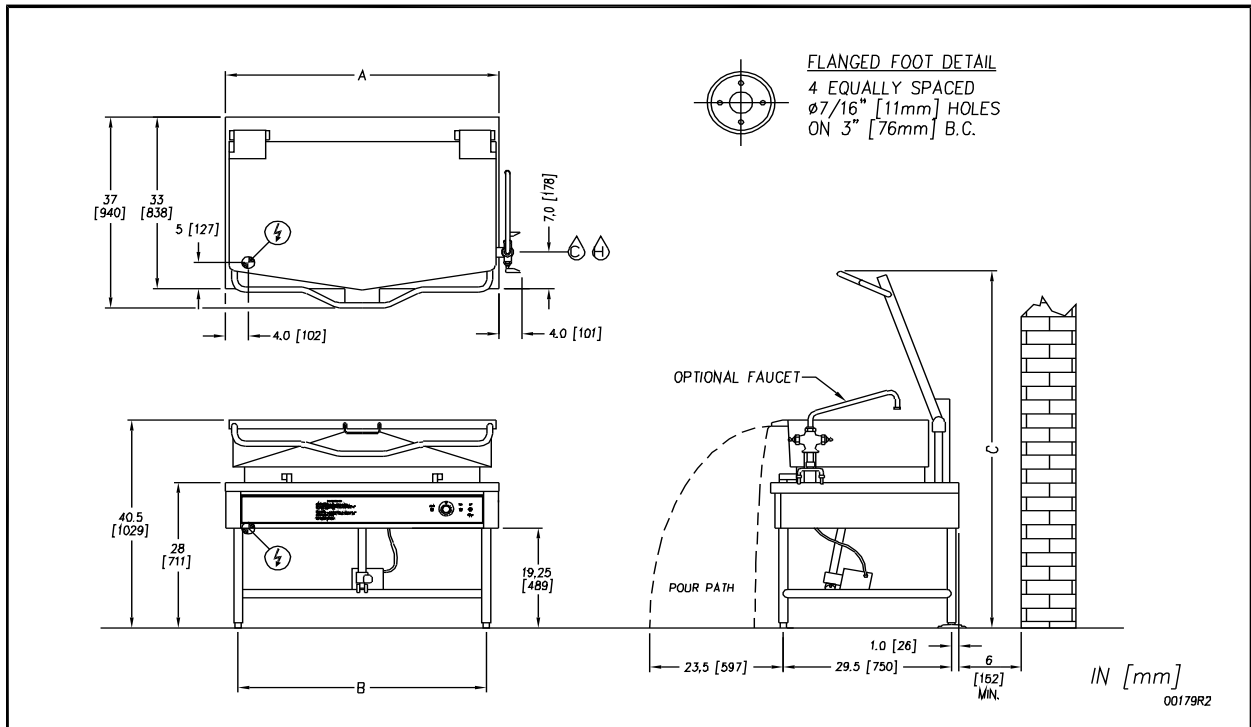

As continued product improvement is a policy of Crown, specifications are subject to change without notice.

3.0 INSTALLATION INSTRUCTIONS

UNPACKING

Immediately after unpacking, check for possible shipping damage. If the tilting braising pan is found to be damaged, save the packaging material and contact the carrier within 15 days of delivery.

Before installing, verify that the electrical service agrees with the specifications on the rating plate located on the left side panel as you face the front of the braising pan. If the supply and equipment requirements do not agree, contact your dealer or Crown Food Service Equipment Ltd.

LOCATION

The installation location must allow adequate clearances for servicing and proper operation. A minimum front clearance of 36", and rear clearance of 6" is required.

INSTALLATION CODES AND STANDARDS

Your Crown Tilting Braising Pan must be installed in accordance with:

1. Provincial and local codes, or in the absence of local codes, with: C.S.A. C22.1 Canadian Electrical Code, Part 1, or in the U.S.A. state and local codes, or in the absence of local codes, with the National Electrical Code ANSI/NFPA-70 (latest edition).
2. ANSI NFPA Standard #96, "Vapor Removal from Cooking Equipment," (latest edition), available from the National Fire Protection Association, Batterymarch Park, Quincy, MA 02269.

INSTALLATION INSTRUCTIONS (Continued)

LEVELLING AND ANCHORING TILTING BRAISING PAN

1. Place tilting braising pan in the installation position.
2. Place a carpenter's level on top of the braising pan and turn the adjustable feet to level braising pan side-to-side and front-to-back.
3. Mark hole locations on the floor through the anchoring holes provided in the rear flanged adjustable feet.
4. Remove tilting braising pan from installation position and drill holes in locations marked on the floor. (See installation diagram on page 4.) Insert proper anchoring devices (not supplied).
5. Place tilting braising pan back in the installation position.
6. Place carpenter's level on top of braising pan and re-level side-to-side and front-to-back.
7. Bolt and anchor tilting braising pan securely to the floor.
8. Seal bolts and flanged feet with silastic or equivalent compound.

ELECTRICAL CONNECTIONS



WARNING: Electrical and grounding connections must comply with the applicable portions of the National Electrical Code and/or other local codes.



WARNING: Before performing any maintenance disconnect the electrical power supply and place a tag at the disconnect switch to indicate that you are working on the circuit.

The wiring compartment is located behind the control panel. Refer to Page 4 Service Connections.

1. Remove the wiring compartment cover and make electrical connections per the wiring diagram located inside the control housing cover panel. (The braising pan must be grounded in accordance with requirements of the National Electrical Code or applicable local codes.) See warning (page 6). Connection from incoming lines must be waterproof.
2. Ground skillet to terminal provided in control housing. A wiring diagram is provided and is located inside the control cover panel.
3. Replace wiring compartment cover.

SERVICE CONNECTIONS

All internal wiring for the skillet is complete.

Make service connections as indicated on page 4 and electrical connections above.

If a faucet is provided, connect the water supplies and check for proper operation.

4.0 OPERATION INSTRUCTIONS



WARNING: The tilting braising pan and its parts are hot. Use care when operating, cleaning and servicing the tilting braising pan.

BEFORE FIRST USE

Using a non-corrosive, grease-dissolving commercial cleaner, clean the protective metal oils from all surface parts and the interior of the tilting braising pan. Follow the cleaner manufacturer's directions. Rinse thoroughly and drain the pan. Wipe dry with a soft clean cloth.

CONTROLS (Figure 1)

- Red Temperature Light** - Illuminates when heating elements are supplying heat to the tilting braising pan.
- Thermostat** - Turns tilting braising pan ON and maintains set temperature by controlling power supply. Temperature settings range from 1 to 10, (See COOKING GUIDELINES in this manual for temperature ranges for settings 1-10.) or may have temperature on the dial in either °C or °F.
- Tilt Switch** - Push UP to raise tilting braising pan; push DOWN to lower tilting braising pan.

Figure 1

START-UP PROCEDURE

1. Ensure that the braising pan is in the DOWN position.
2. Turn THERMOSTAT dial to desired temperature (reference Cooking Guidelines, Page 11). The red TEMPERATURE light will come on.
3. When braising pan has reached set temperature, the red TEMPERATURE light will go off and the heating elements will shut off. The heating elements will cycle on and off thereafter to maintain set temperature. The red TEMPERATURE light will cycle on and off with the heating elements.
4. Preheat braising pan and allow it to cycle to equalize heat across the entire surface.
5. Water will boil faster with the lid down.
6. Turn THERMOSTAT to OFF when braising pan is not in use.

DAILY SHUTDOWN PROCEDURE

To turn tilting braising pan off, turn THERMOSTAT dial to OFF.

TILTING THE BRAISING PAN

1. DO NOT try to tilt braising pan with lid down.
2. Make sure the receiving pan is in place.
3. To tilt braising pan, push and hold TILT SWITCH in the UP mode until desired pan position has been reached. The braising pan will empty when raised to the top tilt position.
5. To lower braising pan, push and hold TILT SWITCH in the DOWN mode.

When the braising pan is raised 5° or more, the heating elements will be turned off automatically.

4. Food is poured through the removable strainer into a food receiving pan positioned under the lip of the pouring spout (Figure 2).

FIGURE 2

NOTE

Excessive, consecutive lifts may cause the motor to overheat and activate the thermal overload causing the motor to shut down.

Should this occur, a cooling off time will be necessary to reset and continue the lifting operation.

5.0 CLEANING INSTRUCTIONS



WARNING: Disconnect electrical power supply before cleaning.

Before cleaning allow the tilting braising pan to cool and then clean it. Keep exposed cleanable areas of the tilting braising pan clean at all times. Do not get water in electrical box or any electrical component.

1. Thoroughly wash pan, pouring spout (see Figure 2), lid and exterior surfaces with detergent and warm water. If necessary, soak pan to remove food that is stuck to pan surface. Rinse thoroughly and wipe dry with a soft clean cloth.
2. Clean removable strainer and receiving pan support (Figure 2) with detergent and warm water. Rinse thoroughly and wipe dry with a soft clean cloth.

INSTALLATION AND OPERATION MANUAL, ELECTRIC POWER TILT SKILLETTS, ELTS-30,
ELTS-40

6.0 COOKING GUIDELINES

The guidelines given below are suggested quantities, temperature settings, and **estimated** numbers of orders per load and per hour. When two temperatures are given, the first is to start the product, and the second to finish the product.

The following temperatures should be used:

	<u>Temperature (°F)</u>	<u>Thermostat Setting</u>
Simmering	200 Maximum	1 - 4
Sautéing	225 - 275	5 - 6
Searing	300 - 350	7 - 8
Frying	325 - 375	8 - 9
Grilling	350 - 450	9 - 10

<u>ITEM</u>	<u>PORTION SIZE</u>	<u>TEMP. (°F)</u>	<u>BATCHES PER HOUR</u>	<u>ELTS-30 PER LOAD QTY.</u>	<u>PORTIONS</u>	<u>ELTS-40 PER LOAD QTY.</u>	<u>PORTIONS</u>
BREAKFAST FOODS							
Bacon	3 slices	350	12	2 lbs.	10	3 lbs.	15
Eggs							
- Boiled - Hard	1 egg	225	5	50 eggs	50	75 eggs	75
- Boiled-Soft	1 egg	225	8	50 eggs	50	75 eggs	75
- Fried	1 egg	400	4	30 eggs	30	45 eggs	45
- Poached	1 egg	225	5	36 eggs	36	60 eggs	60
- Scrambled	1-1/2 eggs	300 - 200	1	18 gal.	720	28 gal.	1100
French Toast	3 slices	450	7	35 slices	12	50 slices	17
Regular Oatmeal	½ cup	250	2	20 lbs. (100 cups)	500	40 lbs. (200 cups)	1000
Pancakes	2 each	400	10	30 ea.	15	50 ea.	25

INSTALLATION AND OPERATION MANUAL, ELECTRIC POWER TILT SKILLETTS, ELTS-30,
ELTS-40

<u>ITEM</u>	<u>PORTION SIZE</u>	<u>TEMP. (°F)</u>	<u>BATCHES PER HOUR</u>	<u>ELTS-30</u>		<u>ELTS-40</u>	
				<u>PER LOAD QTY.</u>	<u>PORTIONS</u>	<u>PER LOAD QTY.</u>	<u>PORTIONS</u>
FISH							
Clams	1 pt.	400	10	10 qts.	20	15 qts.	30
Fish Cakes	2 - 3 oz.	400	5	70 - 3 oz.	35	110 - 3 oz.	55
Haddock Fillet	4 oz.	400	4	60 - 4 oz.	60	90 - 4 oz.	90
Halibut Steak	5 oz.	450	3	60 - 4 oz.	60	90 - 4 oz.	90
Lobster	1 - 1 lb.	350	4	20 - 1 lb.	20	30 - 1 lb.	30
Swordfish	5 oz.	450	3	50 - 5 oz.	50	75 - 5 oz.	75
SAUCES, GRAVIES, SOUPS							
Brown Gravy	1 oz.	350 - 200	2	18 gal.	2300	35 gal.	450 0
Cream Sauce	2 oz.	250 - 175	1	18 gal.	1150	35 gal.	225 0
Cream Soup	6 oz.	200	1	18 gal.	375	35 gal.	725
French Onion Soup	6 oz.	225	1	18 gal.	350	35 gal.	700
Meat Sauce	4 oz.	350 - 200	1	18 gal.	575	35 gal.	110 0
VEGETABLES							
CANNED							
	3 oz.	400	6	30 lbs.	125	45 lbs.	200
FRESH							
Beans, Wax, Green	3 oz.	400	3	25 lbs.	125	50 lbs.	250
Beets	3 oz.	400	1	30 lbs.	125	60 lbs.	300
Broccoli	3 oz.	400	3	25 lbs.	125	40 lbs.	200
Cabbage	3 oz.	400	5	20 lbs.	80	30 lbs.	125
Carrots	3 oz.	400	2	35 lbs.	150	70 lbs.	300

INSTALLATION AND OPERATION MANUAL, ELECTRIC POWER TILT SKILLETTS, ELTS-30,
ELTS-40

ITEM	PORTION SIZE	TEMP. (°F)	BATCHES PER HOUR	ELTS-30 PER LOAD		ELTS-40 PER LOAD	
				QTY.	PORTIONS	QTY.	PORTIONS
Cauliflower	3 oz.	250	5	15 lbs.	75	25 lbs.	125
Corn	1 ear	400	8	50 ears	50	75 ears	75
Potatoes	3 oz.	400	2	40 lbs.	200	60 lbs.	300
Spinach	4 oz.	250	10	6 lbs.	25	9 lbs.	35
Turnips	4 oz.	400	2	20 lbs.	100	30 lbs.	150
FROZEN							
Beans, French Green	3 oz.	400	6	15 lbs.	60	22-1/2 lbs.	90
Lima Beans	3 oz.	250	4	15 lbs.	60	22-1/2 lbs.	90
Broccoli	3 oz.	400	8	12 lbs.	50	18 lbs.	75
Sliced Carrots	3 oz.	250	6	15 lbs.	60	22-1/2 lbs.	90
Small Whole Carrots	3 oz.	250	3	15 lbs.	50	22-1/2 lbs.	90
Corn	3 oz.	250	18	15 lbs.	50	22-1/2 lbs.	90
Small Whole Onions	3 oz.	250	7	15 lbs.	50	22-1/2 lbs.	90
Peas	3 oz.	400	10	15 lbs.	75	22-1/2 lbs.	110
Spinach	3 oz.	400	3	15 lbs.	75	22-1/2 lbs.	110
DESSERTS, PUDDINGS, SWEET SAUCES							
Butterscotch Sauce	1 oz.	200	1	18 gal.	2300	35 gal.	450 0
Cherry Cobbler	3 oz.	200	1	18 gal.	750	35 gal.	150 0
Chocolate Sauce	1 oz.	200	1	18 gal.	2300	35 gal.	450 0
Cornstarch Pudding	4 oz.	200	1	18 gal.	575	35 gal.	110 0

INSTALLATION AND OPERATION MANUAL, ELECTRIC POWER TILT SKILLETTS, ELTS-30,
ELTS-40

<u>ITEM</u>	<u>PORTION SIZE</u>	<u>TEMP. (°F)</u>	<u>BATCHES PER HOUR</u>	<u>ELTS-30 PER LOAD</u>		<u>ELTS-40 PER LOAD</u>	
				<u>QTY.</u>	<u>PORTIONS</u>	<u>QTY.</u>	<u>PORTIONS</u>
Fruit Gelatin	3 oz.	250	2	18 gal.	750	35 gal.	150 0
MEAT-POULTRY							
Bacon	3 slices	350	12	2 lbs.	10	3 lbs.	15
BEEF							
American Chop Suey	6 oz.	400 - 225	2	18 gal.	350	35 gal.	700
Beef Stew	8 oz.	300	-	18 gal.	280	35 gal.	560
Corned Beef Hash	5 oz.	400	5	16 lbs.	50	25 lbs.	75
Cheeseburger	3 oz.	300	12	7 lbs.	35	10 lbs.	50
Hamburger	3 oz.	300	15	7 lbs.	35	10 lbs.	50
Meatballs	1 oz.	400 - 225	3	12-1/2 lbs.	65	18 lbs.	100
Pot Roast	2 oz.	350 - 200		120 lbs.	500	180 lbs.	750
Salisbury Steak	5 oz.	400	3	16 lbs.	50	24 lbs.	75
Sirloin Steak	6 oz.	400	5	15 lbs.	40	22-1/2 lbs.	60
Swiss Steak	4 oz.	300 - 200	1	25 lbs.	110	40 lbs.	160
CHICKEN							
Pan Fried	2-1/4's	350	3	50 pieces	25	80 pieces	40
Whole	2 oz.	350 - 200		16 - 5 lbs.	200	24-5 lbs.	265
FRANKFURTERS							
Grilled	2 oz.	300	8	22 lbs.	176	33 lbs.	264
Boiled	2 oz.	250	12	16 lbs.	128	25 lbs.	200

INSTALLATION AND OPERATION MANUAL, ELECTRIC POWER TILT SKILLETTS, ELTS-30,
ELTS-40

<u>ITEM</u>	<u>PORTION SIZE</u>	<u>TEMP. (°F)</u>	<u>BATCHES PER HOUR</u>	<u>ELTS-30 PER LOAD</u>		<u>ELTS-40 PER LOAD</u>	
				<u>QTY.</u>	<u>PORTIONS</u>	<u>QTY.</u>	<u>PORTIONS</u>
PORK							
Ham Steak	3 oz.	400	8	10 lbs.	50	15 lbs.	75
Pork Chops	5 oz.	350	4	15 lbs.	50	25 lbs.	75
Sausage Links	3 links	350	7	30 lbs.	120	45 lbs.	180
TURKEY							
Off Carcass	2 oz.	400 - 200	–	3 26-30 lbs.	200	4 26-30 lbs.	275
On Carcass	2 oz.	400 - 200	–	4 16-20 lbs.	175	6 16-20 lbs.	265
MISCELLANEOUS							
Grilled Cheese Sandwich	1 sandwich	400	8	35 sandwiches	35	50 sand.	50
Macaroni & Cheese	8 oz.	200	2	18 gal.	300	35 gal.	525
Rice	4 oz.	350 - 225	1	20 lbs. raw	320	40 lbs. raw	650
Spaghetti	4 oz.	350 - 225	2	8 lbs. raw	200	12 lbs. raw	300

7.0 MAINTENANCE



WARNING: The tilting braising pan and its parts are hot. Use care when operating, cleaning and servicing the tilting braising pan.



WARNING: Disconnect electrical power supply and place a tag at the disconnect switch to indicate that you are working on the circuit before performing any maintenance.

ADJUSTMENTS

All tilting braising pans are adjusted at the factory.

At least twice a year, have an authorized service person clean and adjust the tilting braising pan for maximum performance.

8.0 TROUBLESHOOTING

HEATING ELEMENTS DO NOT COME ON:

1. Power supply not "ON".
2. Pan not in down position.
3. Defective thermostat or elements.
4. Defective limit switch or activator mechanism.
5. Defective contactors.

PAN WILL NOT OPERATE (UP OR DOWN):

1. Power supply not "ON".
2. Motor has overheated and thermal overload has shut down motor. Wait 15 to 20 minutes and try again.

The gear reducer is sealed and permanently lubricated with a high grade synthetic grease.

IMPORTANT NOTICE:

Your skillet is equipped with a thermally protected motor which raises and lowers the pan. Continuous operation of 8 or more cycles may cause the motor to overheat and shut down. Should this occur wait approximately 15 to 20 minutes for motor to cool. Motor should then be ready for operation. To avoid this occurring DO NOT run motor continuously for more than a few cycles.