



DIRECT STEAM LEG TILTING KETTLE



- DLT-20
- DLT-30
- DLT-40
- DLT-60
- DLT-80
- DLT-100

OPERATION SHALL BE BY:

Direct steam at a minimum of 5 PSI (34kPa) and a maximum of 30 PSI (206kPa).

OPTIONS & ACCESSORIES AT ADDITIONAL COST

- | | | |
|---|--|---|
| <input type="checkbox"/> 50 PSI (345kPa) high pressure operation for higher cooking temperature | <input type="checkbox"/> One piece lift off cover (C-) | <input type="checkbox"/> Solid stainless steel disc for draw-off valve (TSS-) |
| <input type="checkbox"/> 2" (50 mm) draw off-valve (TVT-2) with perforated strainer (TPS-) | <input type="checkbox"/> Triple basket assembly (TBA-) | <input type="checkbox"/> Graduated measuring strip (CMS-) |
| <input type="checkbox"/> 3" (76 mm) draw off-valve (TVT-3) with perforated strainer (TPS-) | <input type="checkbox"/> Steam control assembly (STA-2) | <input type="checkbox"/> Strainer hook (SH) |
| <input type="checkbox"/> Spring assist hinged cover for 20, 30 or 40 gallon models (CH-) | <input type="checkbox"/> Single pantry faucet with swing spout (SF-18) | <input type="checkbox"/> Pour lip strainer (TKS-) |
| <input type="checkbox"/> Etched gallon markings (GM-) | <input type="checkbox"/> Double pantry faucet with swing spout (DF-18) | <input type="checkbox"/> Pan carrier (PC-4) |
| <input type="checkbox"/> Etched litre markings(LM-) | | <input type="checkbox"/> Kettle heat shield (KHS-) |

STANDARD CONSTRUCTION SPECIFICATIONS

Shall be a Crown model DLT-20, DLT-30, DLT-40, DLT-60, DLT-80, or DLT-100, direct steam connected tri-leg tilting kettle.

A double wall kettle interior shall form a steam jacket around the lower 2/3 of the kettle.

The bottom of the kettle shall be of hemispherical design for superior heat circulation.

The tri-leg mounting frame (60,80,&100 on 4 legs) of stainless steel pipe shall support the kettle and tilt console, conceal the steam piping and house the steam control valve and tilt mechanism.

Each leg shall be fitted with a 4 hole adjustable flanged foot for securing to the floor.

The tilt mechanism shall permit the kettle to tilt forward a full 90° for complete emptying.

The tilting mechanism shall be self locking for positive stop action.

Construction shall be all welded #4 finish stainless steel type 304.

The interior liner shall be standard 316 for high acid content cooking.

Faucet bracket included.



Approval Notes: _____

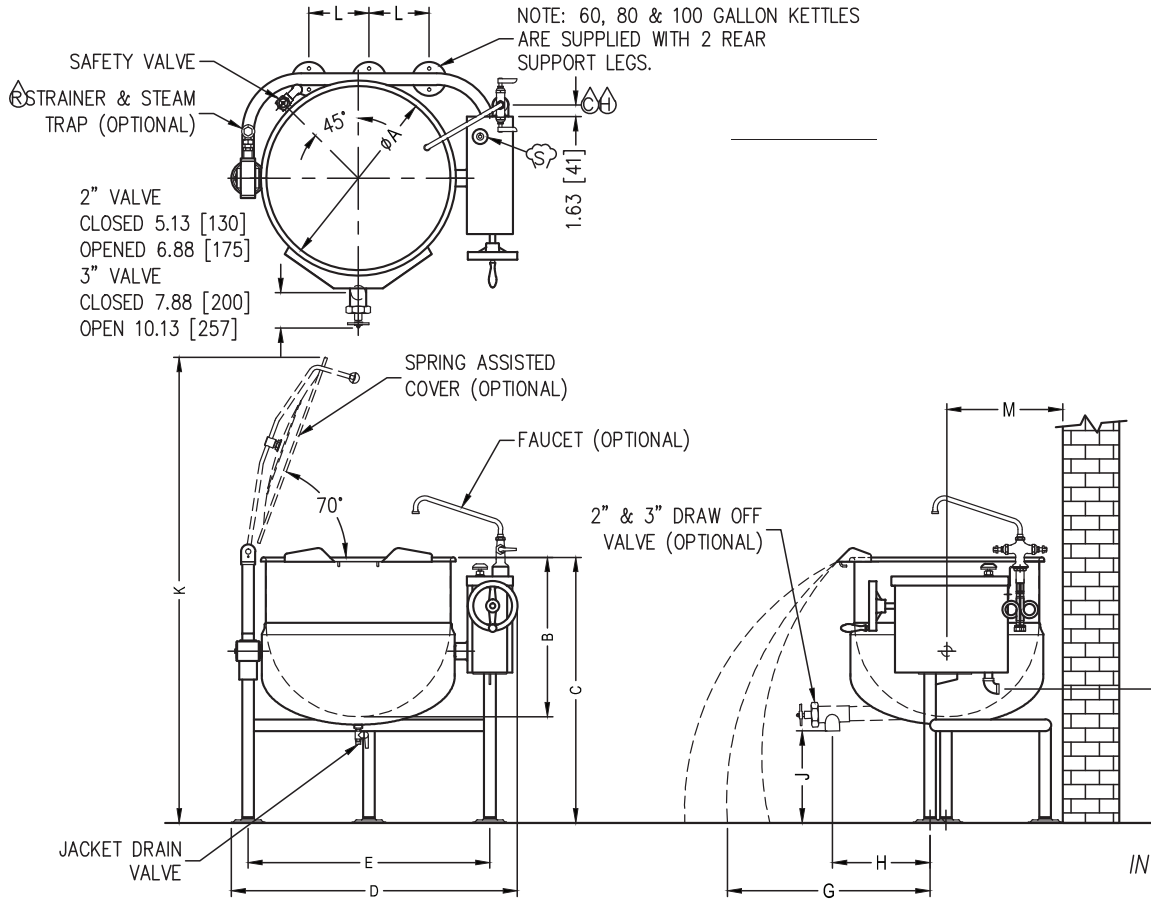

SERVICE CONNECTIONS

- STEAM SUPPLY: 3/4" IPS (19 mm) 5-30 PSI (34-206 kPa). Optional 5-45 PSI (34-310 kPa).
- CONDENSATE RETURN: 1/2" IPS (13 mm)
- COLD WATER: 3/8" O.D. tubing to faucet. (OPTIONAL)
- HOT WATER: 3/8" O.D. tubing to faucet. (OPTIONAL)

(Pressure reducing valve required if pressure is over 50 PSI)

DIMENSIONS

MODEL	CAPACITY	UNITS	A	B	C	D	E	F	G	H(2")	H(3")	J(2")	J(3")	K	L	M
DLT-20	20 gallons (76 liters)	in (mm)	21" (533)	18" (460)	37" (940)	34.75" (885)	28.5" (724)	20.38" (518)	25.63" (651)	12" (305)	13.25" (337)	17" (432)	16.13" (410)	60.63" (1540)	N/A	15.38" (391)
DLT-30	30 gallons (114 liters)	in (mm)	24" (610)	20" (510)	37" (940)	37.75" (960)	31.5" (800)	19.88" (505)	27.13" (689)	13.13" (333)	14.25" (362)	15" (381)	14.5" (368)	63.25" (1607)	N/A	15.38" (391)
DLT-40	40 gallons (152 liters)	in (mm)	26" (660)	22.5" (570)	37" (940)	39.88" (1013)	33.5" (850)	18.38" (467)	28.63" (727)	13.75" (349)	15.25" (387)	12.5" (318)	12" (305)	65.25" (1657)	N/A	16.38" (416)
DLT-60	60 gallons (227 liters)	in (mm)	29.5" (750)	26" (660)	40.5" (1029)	43.25" (1100)	37" (940)	19.25" (489)	30.13" (765)	15.5" (394)	16.88" (429)	14" (356)	14" (356)	74" (1879)	9.5" (241)	18.38" (467)
DLT-80	80 gallons (303 liters)	in (mm)	33" (840)	28" (710)	42.5" (1080)	46.75" (1085)	40.5" (1030)	20.25" (514)	32.63" (828)	17.13" (435)	16.88" (429)	12.5" (318)	12" (305)	77" (1956)	11" (279)	19.88" (505)
DLT-100	100 gallons (379 liters)	in (mm)	35.5" (902)	30" (762)	42.5" (1080)	49.25" (1251)	43" (1092)	19.13" (486)	39.25" (997)	18" (457)	20.25" (514)	10.5" (267)	10" (254)	79.25" (2013)	12.5" (318)	21.5" (546)

SPECIFICATIONS

MODEL	SHIPPING WEIGHT	MINIMUM CLEARANCE		MODEL	SHIPPING WEIGHT	MINIMUM CLEARANCE	
DLT-20	215 lbs. [98 kg]	SIDES BACK	0 [0] 0 [0]	DLT-60	385 lbs. [177 kg]	SIDES BACK	0 [0] 0 [0]
DLT-30	285 lbs. [129 kg]			DLT-80	424 lbs. [192 kg]		
DLT-40	332 lbs. [151 kg]			DLT-100	480 lbs. [218 kg]		

**INTENDED FOR COMMERCIAL USE ONLY.
NOT FOR HOUSEHOLD USE.**

