



MARKET FORGE

IMPORTANT FOR FUTURE REFERENCE

Please complete this information and retain this manual for the life of the equipment:

Model #: _____

Serial #: _____

Date Purchased: _____

INSTALLATION & OPERATION MANUAL ECO-TECH® PLUS ; U_g Convection GHYUa Yf 9 HD!%\$;

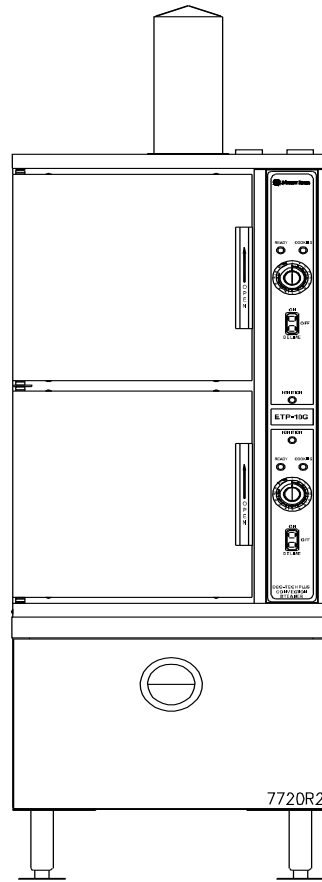

⚠ WARNING

Improper installation, adjustment, alteration, service or maintenance can cause property damage, injury or death. Read the installation, operating and maintenance instructions thoroughly before installing or servicing this equipment.

CROWN FOOD SERVICE EQUIPMENT

 A Middleby Company

70 Oakdale Road, Downsview (Toronto) Ontario, Canada, M3N 1V9

Telephone: 919-762-1000 www.crownsteamgroup.com

Printed in Canada





IMPORTANT NOTES FOR INSTALLATION AND OPERATION

Retain this manual for future reference.

	<p>This is the safety alert symbol. It is used to alert you to potential personal injury hazards. Obey all safety messages that follow this symbol to avoid possible injury or death.</p>
---	--

	<p>WARNING: Improper installation, adjustment, alteration, service or maintenance can cause property damage, injury or death. Read the installation, operating and maintenance instructions thoroughly before installing, servicing or operating this equipment.</p>
---	---

	<p>FOR YOUR SAFETY: Do not store or use gasoline or other flammable vapors and liquids in the vicinity of this or any other appliance.</p>
---	---

	<p>PURCHASER: Instructions to be followed in the event that the operator of this appliance smells gas must be posted in a prominent location. This information shall be obtained by consulting the local gas supplier.</p>
--	---

<p style="text-align: center;">IMPORTANT</p> <p>Do not attempt to operate this unit in the event of power failure.</p> <p>Adequate clearances must be maintained for safe and proper operation.</p> <p>The appliance area must be kept free and clear of combustibles.</p> <p>Do not obstruct the flow of combustion and ventilation air.</p> <p>Contact the factory, the factory representative or a local service company to perform maintenance and repairs should the appliance malfunction. Refer to warranty terms.</p>

<p style="text-align: center;">Intended for commercial use only. Not for household use.</p>
--

TABLE OF CONTENTS

DESCRIPTION	PAGE
1.0 SERVICE CONNECTIONS.	4
2.0 INTRODUCTION.	5
3.0 INSTALLATION.	6
4.0 PERFORMANCE CHECK.	13
5.0 OPERATION INSTRUCTIONS.	14
6.0 COOKING GUIDE	20
7.0 PREVENTIVE MAINTENANCE.	24
8.0 TROUBLESHOOTING.	30
9.0 MAINTENANCE	32

INSTALLATION, OPERATION MANUAL, MODEL ETP-10G

1.0 SERVICE CONNECTIONS

- ⚡ - Electrical Connection to be 120 Volts, 60 Hertz single phase with grounding wire. Furnished with 6 foot cord with 3 prong plug. Maximum amps 2.0.
- 💧 - DRAIN: 1 1/2" O.D. tube to open floor drain. No Solid Connection. Use copper only. 24" length before open air gap opening. (No bends or elbows)
- 🔥 - GAS CONNECTION: 3/4" IPS supply line required.
- ❄️ - COLD WATER: 3/8" NPT at 25-50 PSI(170-345 kPa)

MODEL	SHIPPING WT.	GAS SUPPLY			
		BTU/HR.	kW/HR.	SUPPLY PIPE PRESSURE (W.C.)	
ETP-10G	540 lbs. [245 kg]	84,000	24.6	Natural	
				6"-14" [152-356mm]	11"-14" [279-356mm]

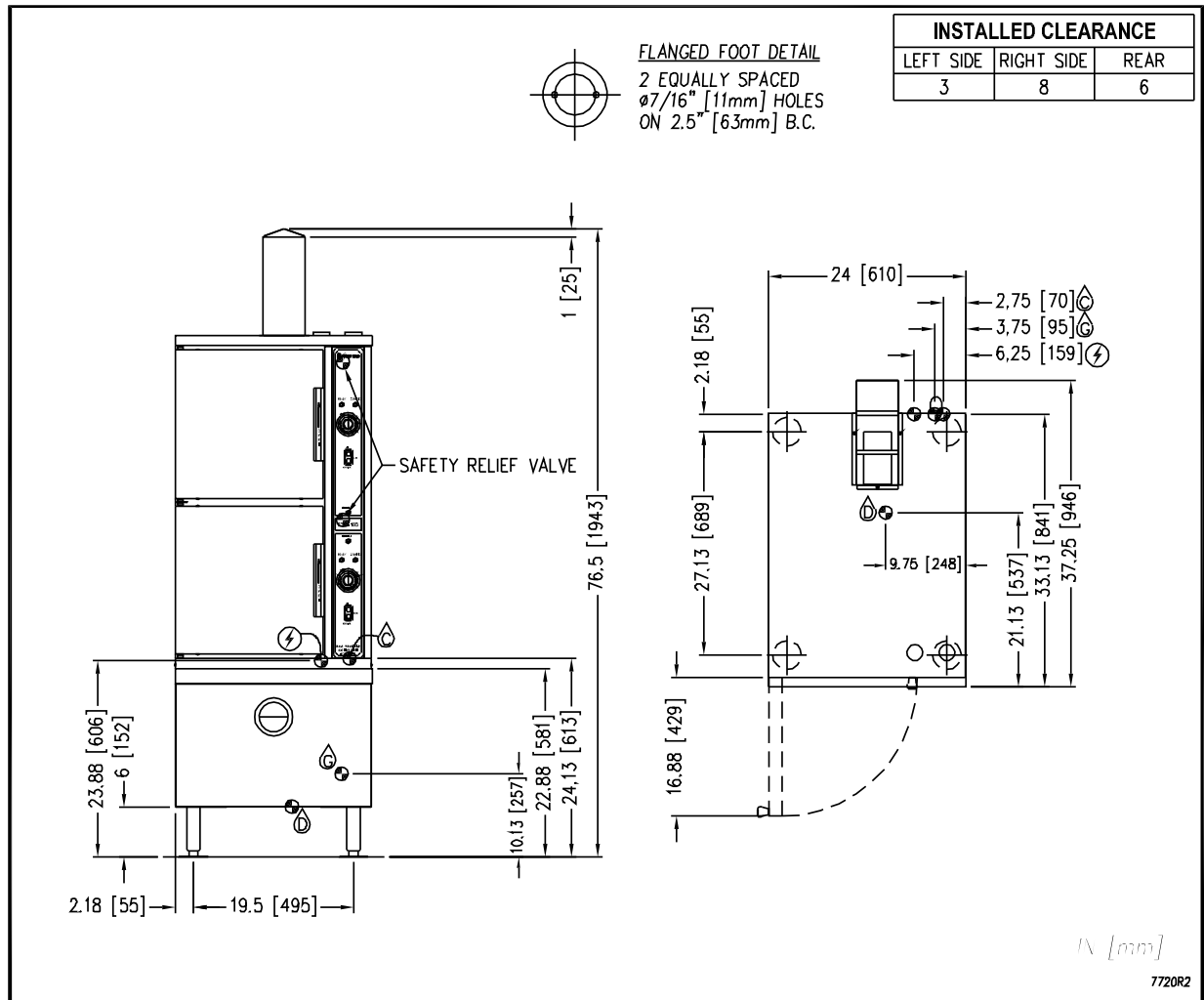

As continued product improvement is a policy of Crown, specifications are subject to change without notice.

2.0 INTRODUCTION

DESCRIPTION

The ETP-10G is a gas fired pressureless steam cooker. The cooking compartments are equipped with a three-piece door with inner gasket plate isolated from the exterior surface. Door latch operates by slam action for positive sealing of the door. Operating controls are displayed on a front-mounted panel and include indicator lights for ignition, ready and cooking modes, a timer to set cook times and a selectable hold cycle to keep food warm once cooked, a temperature display to monitor cavity temperature, and an illuminated ON/OFF/DELIME switch. The ETP-10G is equipped with two generators. Each stainless steel steam generator operates "0" psi (0 kPa) and is rated at 42,000 BTUH.

BASIC FUNCTIONING

The steamer is ready for operation when the READY light comes on.

At the end of the set interval, timer contacts switch to shut off the cooking operation and sound a signal buzzer. The buzzer is silenced by returning the timer dial to the OFF position. In the 'HOLD' mode, the steamer will maintain a safe food holding temperature at or above 150°F. Steam and liquids from each cooking cavity pass through a removable drain screen in the cavity and into the tempering tank. When the appliance is shut off, the steam generators will also drain into the tempering tank. The tempering tank condenses any residual steam and tempers the waste water to 140°F or less.

3.0 INSTALLATION

SETTING IN PLACE

The location of installation must be under an exhaust hood, which will remove water vapour emitted when the cooker door is opened, and exhaust combustion fumes. Level the unit in final location by turning the adjustable feet. Using the cabinet top as a reference, obtain level adjustment left-to-right and front-to-back.

MECHANICAL CONNECTIONS

All electrical and plumbing connections are located on the rear panel of the unit. See 'SERVICE CONNECTIONS' on pages 4 and 5 for location of mechanical connections.

3.1 INSTALLATION CODES AND STANDARDS

Installation must conform with local codes, or in absence of local codes, with the *National Fuel Gas Code - ANSI Z223.1/NFPA 54*, or the *Natural Gas and Propane Installation Code, CSA B149.1* as applicable.

1. The appliance and its individual shut off valve must be disconnected from the gas supply piping system during any pressure testing of that system at pressures in excess of ½ psi (3.5 kPa).
2. The appliance must be isolated from the gas supply piping system by closing its individual manual shut off valve during any pressure testing of the gas supply piping system at test pressures equal to or less than ½ psi (3.5 kPa).

Electrical grounding must be provided in accordance with local codes, or in the absence of local codes, with the National Electrical Code ANSI/NFPA 70, or the Canadian Electrical Code, CSA C22.2 as applicable.

Ventilation must be provided in accordance with local codes, or in the absence of local codes, with *ANSI/NFPA 96 Standard for Ventilation and Fire Protection of Commercial Cooking Operations*.



WARNING: Electrical grounding instructions - Units come equipped with a three-prong (grounding) plug for your protection against shock hazard and should be plugged directly into a properly grounded three-prong receptacle. Do not cut or remove the grounding prong from this plug. (120 VOLT UNITS ONLY)

WIRING DIAGRAM FOR APPLIANCE IS LOCATED ON RIGHT HAND SIDE PANEL OF THE COOKER CABINET.

3.0 **INSTALLATION** (Continued)

3.2 **EXHAUST FANS AND CANOPIES**

Canopies are set over ranges, ovens, kettles, etc., for ventilation purposes. It is recommended that a canopy extend 6" past the appliance and be located 6' 6" from the floor. Filters should be installed at an angle of 45 degrees or more with the horizontal. This position prevents dripping of grease and facilitates collecting the run-off grease in a drip pan, usually installed with the filter. A strong exhaust fan tends to create a vacuum in the room and may interfere with burner performance or may extinguish pilot flames. Makeup air openings approximately equal to the fan area will relieve such vacuum. In case of unsatisfactory performance on any appliance, check with the exhaust fan in the "OFF" position.

3.3 **WALL EXHAUST FAN**

Exhaust fans should be installed at least two feet above the vent opening at the top of the unit.

3.4 **CLEARANCES**

Adequate clearance must be provided in aisle and at the side and back. Adequate clearances for air openings into the combustion chamber must be provided, as well as for serviceability. Minimum clearance from combustible and noncombustible construction, 3" on left side, 8" on right side and 6" from back.



WARNING: These procedures must be followed by qualified personnel or warranty will be voided. An open gap floor drain is required immediately below the appliance drain. See page 12.

To Install:

1. Uncrate carefully. Report any freight damage to the freight company immediately.
2. Set the unit in place. Be certain to maintain the minimum clearances from combustibles and non-combustibles.
3. For an appliance supplied with legs, level the appliance using a spirit level. Rear flanged adjustable feet are provided for permanent anchoring to the floor. With the unit in location, mark hole locations on the floor through the anchoring holes. Remove the steamer and drill holes at marked locations on the floor. Insert proper anchoring devices.
4. Set steamer back in proper position.

3.0 INSTALLATION (Continued)

5. Install bolts through anchoring holes and into anchors to secure the steamer to the floor. Seal bolts and flanged feet with Silastic™ or equivalent silicone sealant.
6. After the drain is connected, check for level by pouring water onto the floor of the compartment. All water should drain through the opening at the back of the compartment cavity.

	<p>WARNING: For an appliance equipped with casters, the installation shall be made with a connector that complies with the Standard for Connectors for Moveable Gas Appliances, ANSI Z21.69/CSA 6.16 and a quick-disconnect device that complies with the Standard for Quick-Disconnect Devices for use with Gas Fuel, ANSI Z21.41/CSA 6.9; adequate means must be provided to limit the movement of the appliance without depending on the connector and the quick-disconnect device or its associated piping to limit the appliance movement: the location where restraining means may be attached is directly above the gas supply inlet pipe on the rear of the appliance.</p> <p>The water inlet connections must also be installed with a flexible water supply tube, a quick disconnect and strain relief.</p>
---	---

GAS CONNECTION:

1. The Serial and Rating Plate on the unit indicates the type of gas your unit is equipped to burn. DO NOT connect to any other gas type.
2. A ¾" NPT line is provided at rear for the connection. Each compartment is equipped with an internal pressure regulator which is set at 3.5" W.C. manifold pressure for natural gas and 10" W.C. for propane gas. Use ⅛" pipe tap on the burner manifold for checking pressure.

An adequate gas supply is imperative. Undersized or low pressure lines will restrict the volume of gas required for satisfactory performance. A steady supply pressure, between 6" W.C. and 14" W.C. for natural gas and 11" W.C. and 14" W.C. for propane gas is recommended. With all units operating simultaneously, the manifold pressure on all units should not show any appreciable drop. Fluctuations of more than 25% on natural gas and 10% on propane gas will create problems, affecting burner operation. Contact your gas company for correct supply line sizes.

3.0 **INSTALLATION** (Continued)

Purge the supply line to clean out any dust, dirt or other foreign matter before connecting the line to the unit. Use pipe joint compound which is suitable for use with LP on all threaded connections.

Test pipe connections thoroughly for gas leaks.



WARNING: Never use an open flame to check for gas leaks. Check all connections for leaks using soapy water before use.

NOTICE: If this equipment is being installed at over 2,000 feet altitude and was not so specified on order, contact service department. Failure to install with proper orifice sizing may void the warranty.

ELECTRICAL CONNECTION:

120 VAC-60 Hz - Single Phase

Units with this electrical rating are factory supplied with a three-wire cord and three-prong plug which fits any standard 120V, three-prong grounded receptacle. A separate 15 amp supply is needed for each unit.

3.0 **INSTALLATION** (Continued)

PLUMBING CONNECTIONS:

	NOTICE: Equipment not installed in accordance to these guidelines may void the warranty.
---	---

	WARNING: Plumbing connections must comply with applicable Sanitary, Safety and Plumbing Codes.
---	---

	WARNING: An obstructed drain can cause personal injury or property damage.
--	---

Connect water supply line at the rear of the steamer.

The water supply line pressure should be 25-50 PSI (1.8 - 3.5 kg/cm²).

Install line strainer (not provided). A manual shut-off valve for supply water line must be provided convenient to the steamer.

3.0 INSTALLATION (Continued)

DRAIN CONNECTIONS:

	<p>WARNING: Directly plumbing a drain line to the tempering tank may cause personal injury or damage to the appliance. Not using the supplied drain adapter will void your warranty.</p> <p>If this equipment is being installed over an open floor drain, the Drain Adapter is not required.</p>
---	--

	<p>CAUTION: PVC OR CPVC are not acceptable materials for drains.</p>
---	---

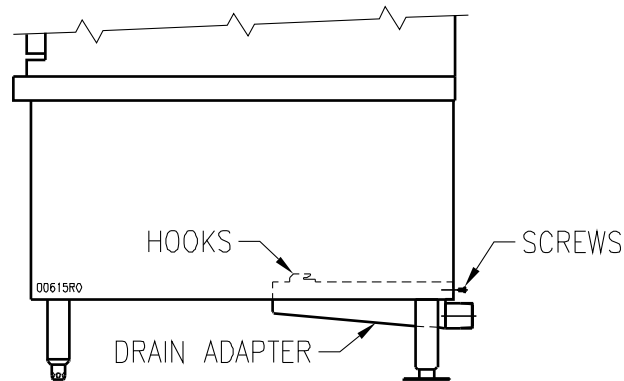

INSTALLING THE DRAIN ADAPTER

From the rear of the unit, position the drain adapter hooks through the slots in the floor of the cabinet to and align with the holes at the rear and fasten in place with provided screws.

When making the drain connection to the 1½" NPT male thread of the drain adapter, use a pipe wrench to firmly support the drain adapter nipple to prevent damage to the assembly.

3.0 INSTALLATION (Continued)

WATER CONDITIONING:

Untreated water contains scale producing minerals which can precipitate onto the surfaces in the steam generator. Due to the temperatures in the steam generator, the minerals can bake onto the surfaces and components. This can result in early component failure and reduced product life. Water level probes become coated with scale. Scale may bridge across the probe insulator from the metal extension which senses the water level in the steam generator shell. Once this scale becomes wet, the water level control is unable to maintain the proper water level in the steam generator.

STRAINERS and FILTERS will NOT treat equipment for scale reduction.

This equipment is furnished with a CUNO® Commercial Series water filtration system. An initial flushing procedure for the filter system must be performed before using this equipment.

FILTER SYSTEM INSTALLATION SET-UP

1. Remove sanitary cap from cartridge. Install cartridge with a quarter turn to the right until cartridge comes to a complete stop. (A "click" is heard). See "Figure 1".
2. a) Lubricate O-ring of scale cartridge with water. Do not use petroleum jelly.
b) Install by turning cartridge toward the right until it comes to a complete stop. DO NOT over tighten. (Never use tools to tighten a cartridge.) See "Figure 2".
3. It is recommended that cartridges be replaced regularly, at no more than six-month intervals to be assured of optimum performance.

FIGURE 1

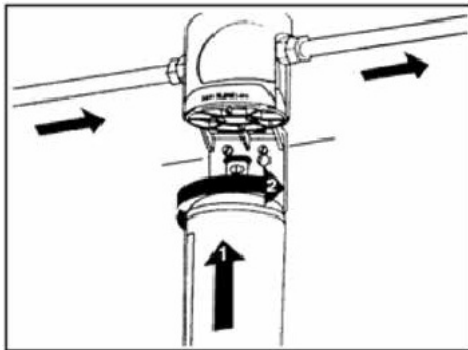
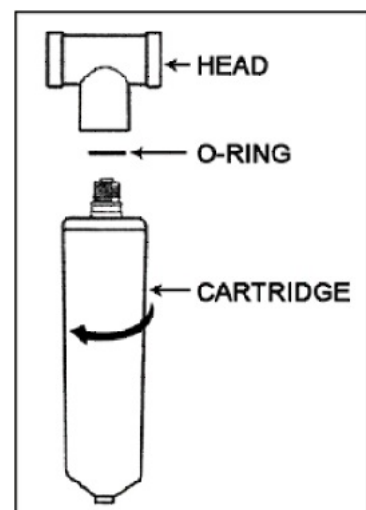

FIGURE 2



4.0 PERFORMANCE CHECK



WARNING: The steamer and its parts are hot. Use care when operating, cleaning or servicing the steamer. The cooking compartment contains live steam. Stay clear while opening door.

Once the steamer is installed and all mechanical connections have been made, thoroughly test the steamer before operation.

1. Check that proper water, drain and electrical and gas connections have been made.
2. Turn main power switch "ON". After approximately 10 minutes, the "READY" light should come on and should remain on, indicating that the water temperature is approximately 200° Fahrenheit (93° Celsius).
3. Check that "IGNITION" light comes on when the burner pilot is ON.
4. When the "READY" light comes on, set timer to the "5 minute" position. With door open, observe that no steam is entering the compartment and that the "COOKING" light is OFF.
5. Close compartment door. The "COOKING" light should now be illuminated and steam should be heard entering the compartment after about 45 seconds.
6. The tempering tank does not discharge to drain until the water in the top of the tank reaches 130°F or the unit is shut off and the generators are allowed to drain.
7. Open compartment door and observe that steam supply to chamber is cut off and the "COOKING" light goes "OFF".
8. Close compartment door and let cooking cycle finish. When the timer returns to "0" position, a buzzer will sound signaling the end of the cooking cycle. Buzzer must be manually turned off by setting the timer to its "OFF" position.
9. Complete the above steps for each cooking compartment.
10. To shut the steamer down, turn the main power switches to OFF and leave the compartment doors slightly open to allow the inside to dry out.

BEFORE FIRST USE

Clean the protective oils from all surfaces of the steamer. Use a non-corrosive, grease dissolving commercial cleaner, following manufacturer's directions. Rinse thoroughly and wipe dry with soft clean cloth.

5.0 OPERATION INSTRUCTIONS

	WARNING: In the event of main burner ignition failure, a 5 minute purge period must be observed prior to re-establishing ignition source. If so equipped, some units will automatically re-attempt ignition.
---	---

	WARNING: In the event a gas odor is detected, shut down equipment at the main shut off valve and contact the local gas company or gas supplier for service.
---	--

LIGHTING

1. Ensure power, gas and water supply is on.
2. Turn power switch "ON".
3. Generator tank will begin filling with water.
4. Once water level has been reached, the ignition light will come on and remain on throughout the operation of the appliance.
5. When the "READY" light comes on the steamer is ready for use.

COOKING

	CAUTION: Live steam and accumulated hot water in the compartment may be released when the door is opened.
---	--

Before loading the steamer, be sure the ready light is on.

1. Slide pans of food into cooking compartment pan supports.
2. Close cooking compartment door.
3. Set timer cooking time:
 - a. 60-MINUTE TIMER - for timed cooking. Set timer to the required cooking time. (See Cooking Guide on page 20).
 - b. HOLD - for holding cooked foods in a warm state. Will maintain the cooking cavity at or above 150°F (65°C).

5.0 OPERATION INSTRUCTIONS (Continued)

4. The cooking cycle may be interrupted at any time by opening the compartment door. To resume operation, close the door.
5. Turn off buzzer, which sounds to indicate cooking is complete, by setting timer dial to the OFF position.
6. Open door slightly at first letting most of the steam out of the compartment and then fully open the door.
7. Unload by sliding pans of food from pan supports.



CAUTION: An obstructed drain can cause personal injury or property damage.

Frequently check that the compartment drain and plumbing is free of all obstructions. Never place food containers, food or food portion bags in the cooking compartment in such a way that the compartment drain becomes obstructed.

Each compartment is equipped with a removable drain screen. Frequently check the drain screen for accumulation of food particles. Should food particles accumulate against, or clog the drain screen, remove it, clean it thoroughly and then replace it in its original position.

SHUTDOWN PROCEDURE

STAND BY

1. Set timer to "OFF" position and leave door slightly open.

END OF THE DAY

1. Set timer to "OFF"
2. Set power switches to "OFF". Generators will drain automatically.
3. Leave doors ajar.

COMPLETE SHUTDOWN

1. Set timers to "OFF" and turn power switches "OFF". Steam generators will drain automatically.
2. Turn water supply "OFF".

5.0 OPERATION INSTRUCTIONS (Continued)

3. Close manual gas shut off valve.
4. Disconnect power supply.

	<p>WARNING: When this appliance is installed with casters and is connected to the supply piping by means of a connector for moveable appliances, a restraint to prevent damage to the connector or quick disconnect device should have been installed. If disconnection of the restraint is necessary, reconnect this restraint after the appliance has been returned to its originally installed position.</p>
---	--

	<p>CAUTION: When the unit is not in use, leave the cooking compartment doors ajar to prolong the life of the door gasket.</p>
---	--

CLEANING

After each period of daily operation (more frequently as required to maintain cleanliness), the steamer should be thoroughly cleaned by completing the following steps:

1. Remove left and right side pan supports by lifting up and off mounting studs. Remove the drain screen in the rear of the compartment. Wash with a mild detergent. Rinse and set aside for reassembly.
2. Wash cooking compartment interior using a mild detergent and water. Rinse and dry thoroughly.
3. Replace pan supports and drain screen in compartment and leave door open.

DRAINAGE

Cooking Compartment Drainage

The bottom of the cooking compartment is angled slightly toward the rear of the unit. This assures that any condensate build-up or spills will be directed toward the drain, which is located at the rear bottom centre of the cooking compartment. Any liquid exiting the cooking compartment runs down the cooking compartment drain tube and into the condensate tempering tank.

5.0 OPERATION INSTRUCTIONS (Continued)

Drip/Spill Trough Drainage

The Pressureless Steam Cooker has a drip/spill trough below the cooking compartment door. It will catch any condensate gathering on the front of the unit when the door is opened.

	<p>WARNING: The steamer and its parts are hot. Use care when operating, cleaning or servicing the steamer. The cooking compartment contains live steam. Stay clear when opening door.</p>
---	--

	<p>CAUTION: An obstructed drain can cause personal injury or property damage.</p>
---	--

CONTROLS

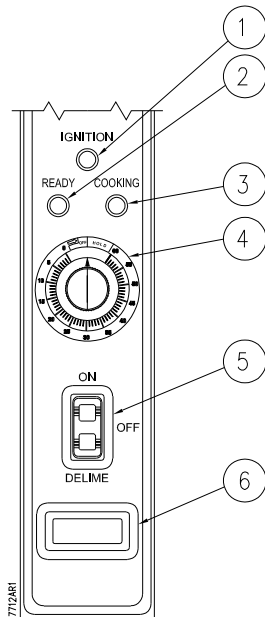

1. Ignition Light

When lit, indicates that pilot burner has been ignited.

2. Ready Pilot Light

When lit, indicates steam generator has reached 200° Fahrenheit (93° Celsius) and is ready for the cooking cycle.

3. Cooking Pilot Light

When lit, indicates that a cooking cycle is in progress.

4. Timed Cooking/Hold Mode

Set the cooking time (0 to 60 minutes) - steam cooking will begin after the door is closed. The cooking cycle will be interrupted if the door is opened during the cooking cycle; resume cooking by closing the door. Hold - For keeping cooked foods warm after cooking, at or above 150 °F (65 °C).

5. Main Power Switch: ON

The steam generator will automatically fill and begin heating to the pre-set temperature for standby. Red light will ignite on the main power switch.

5. Main Power Switch: OFF

The steam generator will drain. No lights.

5. Main Power Switch: DELIME

Closes the drain valve while TOTAL CONCEPT liquid is being poured into the steam generator during the Delime procedure. Amber light will ignite on the main power switch.

6. Temperature Display

Shows temperature within the cooking cavity.

7. Buzzer

Signals end of cooking period (not shown).

5.0 OPERATION INSTRUCTIONS (Continued)



CAUTION: Live steam and accumulated hot water in the compartment may be released when the door is opened.

ADJUSTMENT FOR HIGH ALTITUDE LOCATIONS

Your steamer has been factory set when "ON" to maintain water temperature during the "READY" phase at approximately 200° Fahrenheit (93° Celsius) just below water boiling point. If the steamer is used at higher elevations (above 2000 feet), a qualified technician should adjust the "READY" phase temperature down to an appropriate temperature, below the boiling point of water.

TEST KITCHEN BULLETIN

Pressureless Cooker - Facts On Parade

1. Frozen vegetables should always be cooked in perforated 12" x 20" x 2 ½ " (1/1 65 mm) pans 7 ½ lbs. (34 kg) maximum per pan.
2. Frozen entrees should be underlined with a perforated pan for best results. If they are defrosted first, the heating time will be decreased.
3. Fresh foods may also be cooked in this unit. Vegetables and other foods where the stock is not to be retained should be cooked in perforated 12" x 20" x 2 ½" (1/1 65 mm) pans for the most nutritious results.
4. There is a safety microswitch on the door which shuts off the steam each time the door is opened if the unit is in the cooking cycle.
5. Total cooking time will vary depending on the load, even though the timer setting is the same.
6. All foods, except cakes and pastry, can be cooked in a steam cooking unit.
7. Steam cooked meals have greater nutritional value since they retain most of their vitamins and minerals.
8. Because foods are cooked faster by the higher temperatures of steam cooking, they can be prepared closer to serving time, insuring maximum freshness.
9. Steam cooked foods have a higher percent yield more portions per dollar spent.

5.0 OPERATION INSTRUCTIONS (Continued)

10. Food may be served from the same pan in which it is steam cooked, thus reducing food breakage since there is no extra handling or transferring of food from cooking pans to serving pans. It also reduces pot washing tasks.
11. Some important advantages of steam cooking are labor saving, reduced operating costs, space saving, and the lifting of heavy stock pots is eliminated.
12. Rice and spaghetti products, if thoroughly wet at the start of the cooking process, are very easily prepared.
13. Food such as potatoes, poultry, seafood, and some meats may be blanched in the steam cooker, thus reducing the total cooking time and grease absorption.
14. The steam cooker will loosen foods burned on pans making washing easier.
15. Solid pans are recommended when liquid is to be retained and perforated pans when the liquid is not to be retained.
16. Eggs may be cooked out of the shell if they are to be chopped which eliminates peeling after steaming.
17. The steam cooker can be opened during the cooking period to add or remove items.

INSTALLATION, OPERATION MANUAL, MODEL ETP-10G

6.0 COOKING GUIDE

The cooking times indicated in this list are based on a preheated cooking compartment. Preheat time for the Eco-Tech Plus Steamer is approximately 15 minutes.

ITEM	APPROX. WEIGHT PER PAN	SIZE OF PAN (PERFORATED)	NUMBER OF PANS	TIMER SETTING (MINUTES)	APPROXIMATE NO. COOKED SERVINGS PER PAN 3 OZ.
FROZEN VEGETABLES					
Green Beans, Regular Cut	6 lb	12" x 20" x 2.5"	1 - 5 Pans	15 - 20	24
Green Beans, French Cut	4 lb	12" x 20" x 2.5"	1 - 5 Pans	13 - 18	16
Lima Beans, Baby	5 lb	12" x 20" x 2.5"	1 - 5 Pans	23 - 28	20
Broccoli Spears	6 lb	12" x 20" x 2.5"	1 - 5 Pans	11 - 16	24
Brussel Sprouts	5 lb	12" x 20" x 2.5"	1 - 5 Pans	14 - 19	20
Carrots, Diced	4 lb	12" x 20" x 2.5"	1 - 5 Pans	15 - 21	16
Cauliflower	6 lb	12" x 20" x 2.5"	1 - 5 Pans	13 - 17	24
Corn on the Cob, 3" Ears	27 Ears	12" x 20" x 2.5"	1 - 5 Pans	17 - 21	27
Corn, Nibbles	5 lb	12" x 20" x 2.5"	1 - 5 Pans	13 - 17	20
Mixed Vegetables	5 lb	12" x 20" x 2.5"	1 - 5 Pans	15 - 21	20
Green Peas	6 lb	12" x 20" x 2.5"	1 - 5 Pans	13 - 19	24
Spinach	6 lb	12" x 20" x 2.5"	1 - 5 Pans	Must Be Defrosted	-
Squash, Winter	8 lb	12" x 20" x 2.5" (Solid)	1 - 5 Pans	Must Be Defrosted	1
FRESH VEGETABLES					
Asparagus Spears	4 lb	12" x 20" x 2.5"	1 - 5	15 - 21	16
Beans, Green or Waxed	4 lb	12" x 20" x 2.5"	1 - 5	18 - 27	16
Broccoli Spears	6 lb	12" x 20" x 2.5"	1 - 5	17 - 23	24
Carrots, Sliced	6 lb	12" x 20" x 2.5"	1 - 5	25 - 29	24
Cauliflower	4 lb	12" x 20" x 2.5"	1 - 5	17 - 23	16

INSTALLATION, OPERATION MANUAL, MODEL ETP-10G

ITEM	APPROX. WEIGHT PER PAN	SIZE OF PAN (PERFORATED)	NUMBER OF PANS	TIMER SETTING (MINUTES)	APPROXIMATE NO. COOKED SERVINGS PER PAN 3 OZ.
Corn on the Cob (Husked)	1 dozen	12" x 20" x 2.5"	1 - 5	17 - 23	1 dozen
Green Peas	5 lb	12" x 20" x 2.5"	1 - 5	13 - 17	24
Potatoes, Whole	10 lb	12" x 20" x 2.5"	1 - 5	40 - 45	40
Potatoes, French Fry Cut	10 lb	12" x 20" x 2.5"	1 - 5	17 - 23	40
Spinach	3 lb	12" x 20" x 4"	1 - 5	9 - 11	12
Squash, Summer or Zucchini, 1" slices	5 lb	12" x 20" x 2.5"	1 - 5	10 - 15	24
FISH AND SHELLFISH					
Clams	5 lb	12" x 20" x 2.5"	1 - 5	11 - 13	-
Crabs	6 each	12" x 20" x 2.5"	1 - 5	21 - 27	-
Fish Filets	3 lb	12" x 20" x 2.5"	1 - 5	11 - 13	-
Fish Filets, Covered	3 lb	12" x 20" x 2.5"	1 - 5	14 - 17	-
Fish Filets, Covered in Casserole 6 - 8 oz.	3 per pan	12" x 20" x 2.5"	1 - 5	19 - 21	-
Fish Steak	3 lb	12" x 20" x 2.5"	1 - 5	13 - 17	-
King Crab Legs, Frozen	5 lb	12" x 20" x 2.5"	1 - 5	11 - 13	-
Lobsters, 1-1/4 lb	4 - 5 each	12" x 20" x 2.5"	1 - 5	17 - 23	-
Shrimp, Peeled, Frozen	3 lb	12" x 20" x 2.5"	1 - 5	11 - 13	-
MEAT AND POULTRY					
Chicken, Cut-Up	5 lb	12" x 20" x 2.5"	1 - 5	27 - 37	15 - 20
Chicken, Whole, (1.8 kg)	4 lb	12" x 20" x 2.5"	1 - 5	45 - 55	25 - 30
Frankfurters	5 lb	12" x 20" x 2.5"	1 - 5	10 - 14	20 - 25
Hamburgers, (3 oz.)	5 lb	12" x 20" x 2.5"	1 - 5	23 - 27	20 - 25
Meatballs, 1 oz. Size	6 lb	12" x 20" x 2.5"	1 - 5	27 - 32	35 - 40
Sausages, 10 per lb	6 lb	12" x 20" x 2.5"	1 - 5	23 - 26	18 - 20
MISCELLANEOUS					

INSTALLATION, OPERATION MANUAL, MODEL ETP-10G

ITEM	APPROX. WEIGHT PER PAN	SIZE OF PAN (PERFORATED)	NUMBER OF PANS	TIMER SETTING (MINUTES)	APPROXIMATE NO. COOKED SERVINGS PER PAN 3 OZ.
Eggs in Shell (Hard Cooked)	3 dozen	12" x 20" x 2.5"	1 - 5	19 - 21	-
Eggs in Shell (Soft Cooked)	3 dozen	12" x 20" x 2.5"	1 - 5	10 - 12	-
Eggs, Out of Shell	4 dozen	12" x 20" x 2.5" (Solid)	1 - 5	15 - 19	-
Eggs, Poached	1 dozen	12" x 20" x 2.5"	1 - 5	8 - 10	-
Rice	4 lb	12" x 20" x 2.5"	1 - 5	28 - 30	-
Spaghetti, Raw	2 lb	12" x 20" x 2.5"	1 - 5	19 - 21	-
Spaghetti, Cooked, Refrigerated	3 lb	12" x 20" x 2.5"	1 - 5	8 - 10	-
Spaghetti, Cooked, Frozen	3 lb	12" x 20" x 2.5"	1 - 5	10 - 13	-

STEAM COOKING

Your steamer efficiently cooks vegetables or other foods for immediate serving. Steam cooking should be carefully time controlled. Keep hot food holding time to a minimum to produce the most appetizing results. Prepare small batches, cook only enough to start serving, then cook additional amounts to meet demand. Separate frozen foods into smaller pieces to allow more efficient cooking.

Use a pan cover for pre-cooked frozen dishes that cannot be cooked in the covered containers in which they are packed if they require more than 15 minutes of cooking time. When cover is used, approximately one-third additional cooking time is necessary.

Cooking time for frozen foods depends on amount of defrosting required. If time permits, allow frozen foods to partially thaw overnight in a refrigerator. This will reduce their cooking time.

INSTALLATION, OPERATION MANUAL, MODEL ETP-10G

PREPARATION

Prepare vegetables, fruits, meats, seafood and poultry normally by cleaning, separating, cutting, removing stems, etc. Cook root vegetables in a perforated pan unless juices are being saved. Liquids can be collected in a solid 12" x 20" pan placed under a perforated pan. Perforated pans are used for frankfurters, wieners and similar items when juices do not need to be preserved. Solid pans are good for cooking puddings, rice and hot breakfast cereals. Vegetables and fruits are cooked in solid pans in their own juices. Meats and poultry are cooked in solid pans to preserve their own juices or to retain broth. Canned foods can be heated in their opened cans (cans placed in 12" x 20" solid pans) or the contents may be poured into solid pans.

PAN

The steamer compartment is designed to accept combinations of the pan of 12" x 20" (either solid or perforated) as shown on the following table.

DEPTH OF PAN	NUMBER OF PANS PER COMPARTMENT
1"	10
2 ½"	5
4"	3
6"	2

7.0 PREVENTIVE MAINTENANCE

A good preventive maintenance program begins with the daily cleaning procedure. Additional preventive maintenance operations are presented in this section. In establishments that employ full-time maintenance personnel, the tasks described can be assigned to them. For other installations, tasks requiring mechanical or electrical experience should be performed by an authorized service agency.

The following paragraphs set out the minimum preventive maintenance procedures that must be completed periodically to assure continued trouble-free operation of the steamer.

	CAUTION: Under no circumstances should hardware (or parts) be replaced with a different length, size, or type other than as specified in the parts list. The hardware used in the cooker has been selected or designed specifically for its application, and the use of other hardware may damage the equipment and will void any warranty.
---	--

	WARNING: Disconnect the power supply to the appliance before cleaning or servicing.
---	--

	WARNING: The steamer and its parts are hot. Use care when operating, cleaning or servicing the steamer. The cooking compartment contains live steam. Stay clear when opening door.
---	---

CLEANING DAILY

At the end of each day, or between cooking cycles if necessary:

1. Turn main power switch OFF.
2. Remove pans and racks from compartment and wash in sink.
3. Wash compartment interior with clean water.

7.0 PREVENTIVE MAINTENANCE (Continued)

4. Use warm soapy water with a cloth or sponge to clean exposed bead of door gasket, rinse with warm clear water and wipe with a dry cloth.

Wipe surfaces which touch door gasket with a cloth or sponge and warm soapy water, rinse with warm clear water and wipe with a dry cloth. Do not apply food oils or petroleum solvents or lubricants directly to door gasket or surfaces which touch door gasket.

5. Remove drain screen from inside compartment drain. Using a plastic bottle brush and mild detergent, clean inside the drain opening ensuring there is no food residue or blockage. Clean the drain screen and replace in its original position.

6. Leave door slightly open when steamer is not in use.



CAUTION: Do not use cleaning agents that are corrosive.

NOTICE: Contact the factory, the factory representative or a local service company to perform maintenance and repairs should the appliance malfunction. Refer to warranty terms.

CLEANING WEEKLY

Weekly, or more often if necessary:

1. Clean exterior with a damp cloth and polish with a soft dry cloth.
2. Use a non-abrasive cleaner to remove discolorations.
3. Clean around burner air mixer and orifice if lint has accumulated. Side cover must be removed to clean this area.

Monthly:

1. Clean around burner air mixers, louvered panels if grease or lint has accumulated.

7.0 PREVENTIVE MAINTENANCE (Continued)

Following daily and periodic maintenance procedures will enhance long-life for your equipment. Climatic conditions - salt air - may require more thorough and frequent cleaning otherwise the life of the equipment could be adversely affected.

It is **NOT RECOMMENDED** to use cleaning agents that are corrosive.

Use of cleaning agents that contain chloride, acids or salts which are corrosive may cause pitting and corrosion when used over a period of time; this will reduce the life of the appliance.

Should pitting or corrosion occur, this is not covered by warranty.

Follow the recommended cleaning instructions. Use a mild detergent, warm water and rinse thoroughly.



WARNING: NEVER SPRAY WATER INTO ELECTRIC CONTROLS OR LOUVERS.

REMOVAL OF SCALE DEPOSITS

It is recommended that your steamer be delimed once a month, or more often if necessary.

Should your steamer develop a heavy build-up of lime scale deposits, use the TOTAL CONCEPT TREATMENT KIT available from your authorized service agent.

Before beginning deliming procedures, ensure that water is not overflowing into the cooking compartment.

DELIMING PROCEDURE

Both generators must be delimed individually.



WARNING: Read and follow instructions on the TOTAL CONCEPT bottle. Use plastic or rubber gloves to avoid skin contact. If TOTAL CONCEPT comes in contact with skin, rinse with clean water.



CAUTION: Do not open deliming caps when unit is in operation. Do not open or close compartment doors when deliming caps are not in place.

7.0 **PREVENTIVE MAINTENANCE** (Continued)

GENERATOR DELIMING INSTRUCTIONS



CAUTION: Do not open or close compartment doors or operate unit when deliming caps are not in place.

1. Turn the power switch “OFF” for three minutes, allowing the generators to completely empty.
2. Turn the power switch to the “DELIME” position.
3. Remove caps located on top right of steamer (left cap for top generator, right cap for bottom generator). Using a funnel and pouring slowly to avoid spilling, pour one quart (0.95 litres) of Market Forge’s Total Concept deliming solution into each generator.
4. Replace the deliming caps and tighten. Turn power switch to “ON” for five minutes allowing the generator to completely fill.
5. Turn the power switch to the “DELIME” position. Unscrew the deliming caps and add one quart (0.95 litres) of clean water for gas units, ½ quart (0.48 litres) for electric units.
6. Replace the deliming caps and tighten. Turn the power switch “ON” for 30 minutes. (Timer in OFF position.)
7. Flush the generators three times. Turn power switch to “OFF” for three minutes and then “ON” for five minutes.



WARNING: When this appliance is installed with casters and is connected to the supply piping by means of a connector for moveable appliances, a restraint to prevent damage to the connector or quick disconnect device should have been installed. If disconnection of the restraint is necessary, reconnect this restraint after the appliance has been returned to its originally installed position.

7.0 PREVENTIVE MAINTENANCE (Continued)

FILTER CHANGE PROCEDURE

NOTE: This system is equipped with an internal shut-off valve.

1. Turn cartridge slowly to the left, about 1/4 turn, until it stops (when arrows line up). At this position, both inlet and outlet ports are closed and water pressure has been relieved.
2. Pull used cartridge straight down and discard. Note: There may be a small amount of residual water drainage after pressure is relieved and during cartridge removal.
3. Moisten O-ring with a food grade lubricant and push new cartridge into filter head. Turn cartridge 1/4 turn to the right until it stops (when arrows line up). Top surface of cartridge will become flush with bottom of the head when fully engaged.
4. Open downstream valve (if installed) and flush new filter cartridge for two minutes, expelling any trapped air and carbon fines. Water may run cloudy with air but will quickly clear.

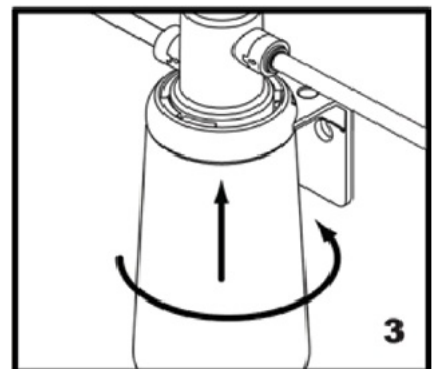
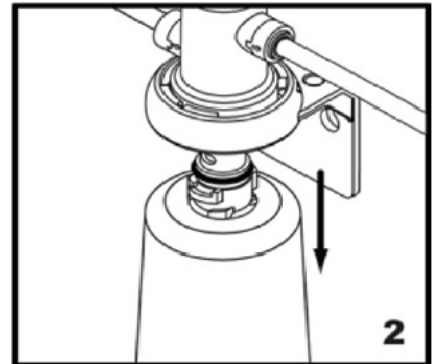
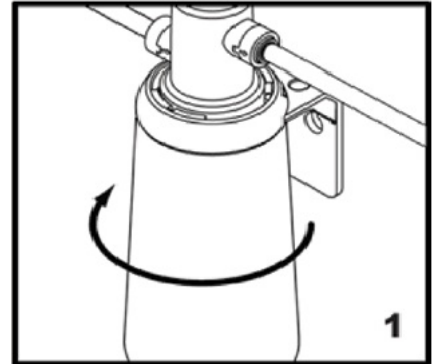

7.0 PREVENTIVE MAINTENANCE (Continued)

To replace scale cartridge:

- a. Shut off inlet water.
- b. Open a downstream valve to relieve pressure (if installed).
- c. Unscrew the cartridge in the direction shown in the illustration and discard.
- d. Lubricate O-ring of new cartridge with water. DO NOT use petroleum jelly.
- e. Install by turning new cartridge toward the right until it comes to a complete stop. DO NOT over tighten. (Never use tools to tighten a cartridge).
- f. Turn on inlet valve, bleed air through a downstream valve (if installed) until water appears clear, and check for leaks. System is now ready for use.

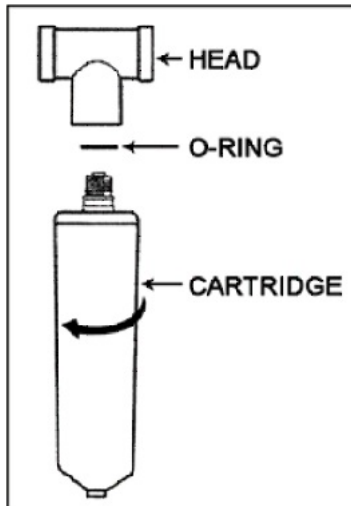

8.0 TROUBLESHOOTING

ADJUSTMENTS



WARNING: At least twice a year, have an authorized service person clean and adjust the unit for maximum performance.



WARNING: Adjustments and service work may be performed only by a qualified technician who is experienced in, and knowledgeable with, the operation of commercial gas cooking equipment. However, to assure your confidence, contact your authorized service agency for reliable service, dependable advice or other assistance, and for genuine factory parts.

All units are adjusted at the factory. In case of operation problems at initial installation, check type of gas and manifold pressure and compare it with information on rating plate.

TROUBLESHOOTING

Pilot does not come on:

1. Gas supply to unit is "OFF."
2. Manual shut off valve is "OFF."
3. Power switch is not turned "ON."
4. Probe not sensing the water level, will not call for ignition.
5. Ignitor or ignition module not functioning.

Burner produces carbon deposits:

1. Wrong orifice size.
2. Wrong gas supply.
3. Incorrect pressure at supply.
4. Dirty primary air openings.
5. Not enough primary air.

8.0 TROUBLESHOOTING (Continued)

Water flows into cooking compartment:

1. Probes not sensing water, thereby not operating fill solenoid.
2. Scale build-up on operating probe inside generator.
3. Water fill solenoid valve is not closed. Check for scale or foreign particles lodged in diaphragm or core tube of valve.

These problems are an indication of severe harmful water conditions which should be corrected immediately to avoid damage to the components and performance of the steamer.

Door leaks:

1. Check for damage to door gasket.
2. Clogged compartment drain or plumbing.

Water accumulates in the compartment:

1. Compartment drain clogged.

Water flows into drain during shut down:

1. Solenoid valve(s) are not closed. Check for scale or foreign particles lodged in diaphragm or core tube of valve.

Water not being supplied to generator:

1. Water supply is "OFF."
2. Supply water pressure too low.
3. Defective water fill solenoid valve.
4. Defective level control board.
5. Shortage of circuit between probes and body.
6. Check that drain solenoid is closed.

9.0 MAINTENANCE



CAUTION: Shut off main electrical power to unit.

Door Gasket Replacement

The cooking compartment door gaskets are made of a silicone-type rubber material that is very durable but subject to wear during normal operation. Should the gasket leak replace it.

1. Open the cooking compartment door.
2. Remove the four screws on the outside of the door frame, and remove the door panel assembly.
3. Remove the six screws from the gasket plate in the door panel assembly.
4. Remove the gasket plate and the door gasket from door panel.
5. Install the new door gasket to the door panel. Replace the gasket plate and six screws.
6. Reassemble the door panel assembly in the door frame using the four screws.
7. Gasket replacement is now complete.

Door may be difficult to close until gasket has compressed to conform to opening. Leaving door closed overnight will compress gasket.

Exterior Panel Removal

Access to all internal plumbing and electrical assemblies is from the right side. The right-side panel is removed by removing the bottom screws from panel. Gas controls are located in the lower cabinet and are accessible from the front of the unit.

9.0 MAINTENANCE (Continued)

STAINLESS STEEL

To remove normal dirt, grease or product residue from stainless steel, use ordinary soap and water (with or without detergent) applied with a sponge or cloth. Dry thoroughly with a clean cloth. Never use vinegar or any corrosive cleaner.

To remove grease and food splatters or condensed vapors that have baked on the equipment, apply cleanser to a damp cloth or sponge and rub cleanser on the metal in the direction of the polishing lines on the metal. Rubbing cleanser as gently as possible in the direction of the polished lines will not mar the finish of the stainless steel. **NEVER RUB WITH A CIRCULAR MOTION.**

Soil and burnt deposits which do not respond to the above procedure can usually be removed by rubbing the surface with **SCOTCH-BRITE** scouring pads or **STAINLESS** scouring pads. **DO NOT USE ORDINARY STEEL WOOL** as any particles left on the surface will rust and further spoil the appearance of the finish. **NEVER USE A WIRE BRUSH, STEEL SCOURING PADS (EXCEPT STAINLESS), SCRAPER, FILE OR OTHER STEEL TOOLS.** Surfaces which are marred collect dirt more rapidly and become more difficult to clean. Marring also increases the possibility of corrosive attack. Refinishing may then be required.

TO REMOVE HEAT TINT

Darkened areas sometimes appear on the stainless steel surface where the area has been subjected to excessive heat. These darkened areas are caused by thickening of the protective surface of the stainless steel and are not harmful. Heat tint can normally be removed by the foregoing, but tint which does not respond to this procedure calls for a vigorous scouring in the direction of the polish lines using **SCOTCH-BRITE** scouring pads or a **STAINLESS** scouring pad in combination with a powdered cleanser. Heat tint action may be lessened by not applying or by reducing heat to equipment during slack periods.

REMOVAL OF SCALE DEPOSITS

See Deliming Procedure, Page 26.