



DESIGNED SMART. BUILT SOLID.®

INSTALLATION AND OPERATING INSTRUCTIONS

Utility Thermo Drawer

Model: SPTU

Intended for other than household use. Unit must be kept clear of combustibles at all times.



WARNING: California Residents Only. This product can expose you to chemicals including chromium which is known to the State of California to cause cancer and birth defects or other reproductive harm. For more information go to www.P65Warnings.ca.gov.



WARNING: For your safety do not store or use gasoline or other flammable vapors or liquids in the vicinity of this or any other appliance. Keep the area free and clear of combustibles. (See ANZI Z83.14B, 1991)



WARNING: Improper installation, operation, service or maintenance can cause property damage, injury or death. Read and understand these instructions thoroughly before positioning, installing, maintaining or servicing this equipment.



APW Wyott® cooking equipment has been engineered to provide you with year-round dependable service when used according to the instructions in this manual and standard commercial kitchen practices.



P/N 8893980 09/18

APW Wyott Food Service Equipment Company
1307 N. Watters Road, Suite 180 • Allen, TX 75013

APW Wyott Food Service Equipment Company is a wholly owned subsidiary of Standex International Corporation.

972.908.6100 Phone
214.565.0976 Fax

+1.800.527.2100
www.apwwyott.com

TABLE OF CONTENTS

ITEM	PAGE	ITEM	PAGE
Safety Precautions	2	General Troubleshooting	5
Specifications	3	Operation/General Description.	6
General Installation Instructions.	4	Exploded View & Parts List	7
General Operating Instructions	4	Wiring Diagram.	10
General Cleaning Instructions	4	Warranty	12

APW Wyott takes pride in the design and quality of our products. When used as intended and with proper care and maintenance, you will experience years of reliable operation from this equipment. To ensure best results, it is important that you read and follow the instructions in this manual carefully.

Installation and start-up should be performed by a qualified installer who thoroughly read, understands and follows these instruction.

If you have questions concerning the installation, operation, maintenance or service of this product, write Technical Service Department APW Wyott, 1307 N Watters Rd # 180, Allen, TX 75013

Location of Data Plate

The data plate for the SPTU is located on the back of the unit.

Immediately Inspect for Shipping Damage

All containers should be examined for damage before and during unloading. The freight carrier has assumed responsibility for its safe transit and delivery. If equipment is received damaged, either apparent or concealed, a claim must be made with the delivering carrier.









- A) Apparent damage or loss must be noted on the freight bill at the time of delivery. It must then be signed by the carrier representative (Driver). If this is not done, the carrier may refuse the claim. The carrier can supply the necessary forms.
- B) Concealed damage or loss if not apparent until after equipment is uncrated, a request for inspection must be made to the carrier within 15 days. The carrier should arrange an inspection. Be certain to hold all contents and packaging material.



Installation and start-up should be performed by a qualified installer who thoroughly read, understands and follows these instructions.



SAFETY PRECAUTIONS



Before installing and operating this equipment be sure everyone involved in its operation are fully trained and are aware of all precautions. Accidents and problems can result by a failure to follow fundamental rules and precautions.



The following words and symbols, found in this manual, alert you to hazards to the operator, service personnel or the equipment. The words are defined as follows:



	DANGER: This symbol warns of imminent hazard which will result in serious injury or death.	
	WARNING: This symbol refers to a potential hazard or unsafe practice, which could result in serious injury or death.	
	CAUTION: This symbol refers to a potential hazard or unsafe practice, which may result in minor or moderate injury or product or property damage.	
	NOTICE: This symbol refers to information that needs special attention or must be fully understood even though not dangerous.	



 **CAUTION:** These models are designed, built, and sold for commercial use. If these models are positioned so the general public can use the equipment make sure that cautions, warnings, and operating instructions are clearly posted near each unit so that anyone using the equipment will use it correctly and not injure themselves or harm the equipment. 



 **WARNING:** SHOCK HAZARD - Do not open any panels that require the use of tools. 



 **WARNING:** Improper installation, adjustment, alteration, service or maintenance can cause property damage, injury or death. Read the Installation, Operating and Maintenance Instructions thoroughly before installing or servicing this equipment. 



 **NOTICE:** The unit when installed, must be electrically grounded and comply with local codes, or in the absence of local codes, with the national electrical code ANSI/NFPA70- latest edition. Canadian installation must comply with CSA-STANDARD C.22.2 Number 0 M1982 General Requirements-Canadian Electrical Code Part II, 109-M1981- Commercial Cooking Appliances. 

 **NOTICE:** Local codes regarding installation vary greatly from one area to another. The National Fire Protection Association, Inc. states in its NFPA96 latest edition that local codes are “Authority Having Jurisdiction” when it comes to requirement for installation of equipment. Therefore, installation should comply with all local codes. 

 **WARNING:** Check the data plate on this unit before installation. Connect the unit only to the voltage and frequency listed on the data plate. Connect only to 1 or 3 phase as listed on the data plate. 

 **WARNING:** Disconnect device from electrical power supply and place a Tag Out-Lockout on the power plug, indicating that you are working on the circuit. 

 **CAUTION:** Maintenance & repair should be handled by a factory authorized agent. Before doing any maintenance or repair, contact APW Wyott. 

 **NOTICE:** Install according to the spacing requirements listed in the installation section of this manual. We strongly recommend having a competent professional install this equipment. A licensed electrician should make the electrical connections and connect power to the unit. Local codes should always be used when connecting these units to electrical power. In the absence of local codes, use the latest version of the National Electrical Code. 

SPECIFICATIONS

Model	Width	Depth	Height	Voltage	Amps
SPTU-30	23.75"	19.25"	4.625"	120	4.1
SPTU-30	23.75" 1	9.25"	4.625"	208/240	2.1 / 2.4
SPTU-30N	19.25" 1	9.25"	4.625"	120	3.0
SPTU-30N	19.25"	19.25"	4.625"	208/240	1.6 / 1.8
SPTU-50	34.75"	19.25"	4.625"	120	7
SPTU-50	34.75"	19.25"	4.625"	208/240	3.6 / 4.2
SPTU-50N	30.25"	19.25"	4.625"	120	5.8
SPTU-50N	30.25"	19.25"	4.625"	208/240	3.0 / 3.5

GENERAL INSTALLATION INSTRUCTIONS

This unit has been inspected and tested at the factory prior to shipment.

Unpack the unit and remove all packing materials. Place on a flat horizontal surface at the desired location.



WARNING: Check the data plate on this unit before installation. Connect the unit only to the voltage and frequency listed on the data plate. Connect only to 1 or 3 phase as listed on the data plate.



WARNING: IMPROPER GROUNDING COULD RESULT IN ELECTRICAL SHOCK! This appliance is equipped with a three prong (grounded) plug for your protection against electrical shock hazard and should be plugged directly into a properly grounded three prong receptacle. Do not cut or remove the grounding prong from this plug.



CAUTION: Do not use ordinary steel wool as any particles left on the surface will rust.



NEVER USE a wire brush, steel or abrasive scouring pads (except stainless), scraper, file or other steel tools. Surfaces which are marred collect dirt more rapidly and become more difficult to clean. Marring also increases the possibility of corrosive attack.

NEVER use any corrosive cleaner. Use only cleaners approved for stainless steel.

NEVER use cleaning solvents with a hydrocarbon base.

General Installation

1. Always clean equipment thoroughly before first use. (See general cleaning instructions)
2. Check ratings label for your model designation and electrical ratings.
3. For best results, use stainless steel countertops.

GENERAL OPERATION INSTRUCTIONS



1. Trained personnel should operate all food service equipment.
2. Do not allow your customers to come into contact with any surface labeled "CAUTION HOT".
3. Where applicable, never pour cold water into dry heated units.
4. Where applicable, do not cook, warm or hold food directly in liner/well pans. Always use steam table pans/inserts, etc.
5. NEVER hold food below 140°F.
6. Power Switch appears lighted when unit is on.



GENERAL CLEANING INSTRUCTIONS

1. Never clean any electrical unit by immersing it in water. Turn the unit off and allow it to cool before surface cleaning.
2. Always clean equipment thoroughly before first use. Clean unit daily. Use warm, soapy water. Mild cleansers and plastic scouring pads may be used to remove baked-on food and water scale on metal unit.
3. Unplug electrical unit before cleaning or servicing. All service should be performed by an APW Wyott authorized service agency.

Daily Cleaning Instructions

1. Allow the unit to cool off.
2. Remove drawer and pan and wash it in hot, soapy water, then rinse. Do not submerge drawer face.
3. If stains are still present add detergent to wash cloth and repeat.
4. Dry with a lint free towel or paper towel.

 **NOTE:** This appliance shall not be cleaned with a water jet. 



 **WARNING:** Shock Hazard – De-energize all power to equipment before cleaning the equipment. 

GENERAL TROUBLESHOOTING

If the unit fails to operate, check the following:

1. Is the unit connected to a live power source?
2. Check the circuit breaker.
3. Is the power switch on and pilot light glowing?
4. Check the data plate. Are you operating the unit on the proper voltage?

If the above checks out and you still have problems, call an APW Wyott authorized service agency.

 **NOTICE:** Service work should be performed only by a qualified technician who is experienced in and knowledgeable with the operation of commercial gas, electric and steam cooking equipment. Contact the Authorized Service Agency for reliable service, dependable advice or other assistance and for genuine factory parts. 

Warranty will be void and the manufacturer is relieved of all liability if:

- A) Service work is performed by other than an APW Wyott Authorized Service Agency Or
- B) Other than Genuine APW Wyott replacement parts are installed.

A current listing of all authorized APW Wyott authorized parts/service distributors is included with this product manual at the time of shipment. In the absence of this list you can call the APW Wyott 24-hour Service Hot Line which gives access to the nearest Authorized APW Wyott parts/service distributor.

Call 1(800)733-2203.

Service

Service work should be performed only by a qualified technician who is experienced in and knowledgeable with the operation of commercial gas, electric and steam cooking equipment. Contact the Authorized Service Agency for reliable service, dependable advice or other assistance and for genuine factory parts.

If the supply cord is damaged, it must be replaced by the manufacturer or its service agent or a similarly qualified person in order to avoid a hazard.

OPERATION / GENERAL DESCRIPTION

SPTU operates as a Heat & Hold oven. The product is loaded in the unit by the operator and heated per the instruction below, insuring the food product has reached the appropriate temperature to meet the depth of health guidelines. The operator then places it on the roller grill above. This methodology prevents cold food product that was just placed on the grill from being selected by the customer.

Hold Mode

- HOLD mode is on when the power switch is turned on and the timer is set to zero.
- This mode will keep product above 150°F after a HEAT cycle has finished.

Heat Mode

- HEAT mode is on when the timer is set to an allotted time.
- After the HEAT Cycle ends and the timer hits zero, the unit will automatically enter HOLD mode.
- Some experimentation will be necessary in determining heat times. The quantity and type of product in the drawer will have an effect on the time it takes to heat to desired temperatures.

OPERATION

1. Open the drawer to expose the controls on the right side of the unit.
2. Turn the unit on using the lighted power switch.
3. Set the timer to 25-30 minutes to preheat the unit.
4. After the preheat period is over, open the drawer and load the roller grill product into the drawer.
5. Set timer for allotted "HEAT" time, the pilot light will come on, signaling the unit is in "HEAT" mode.
6. After product temperature requirements have been met, either remove product from drawer and place on the roller grill, or leave the timer set at zero to enter the hold mode.
7. The HOLD mode will keep the internal temperature of roller grill product above 150°F.

EXPLODED VIEW – SPTU

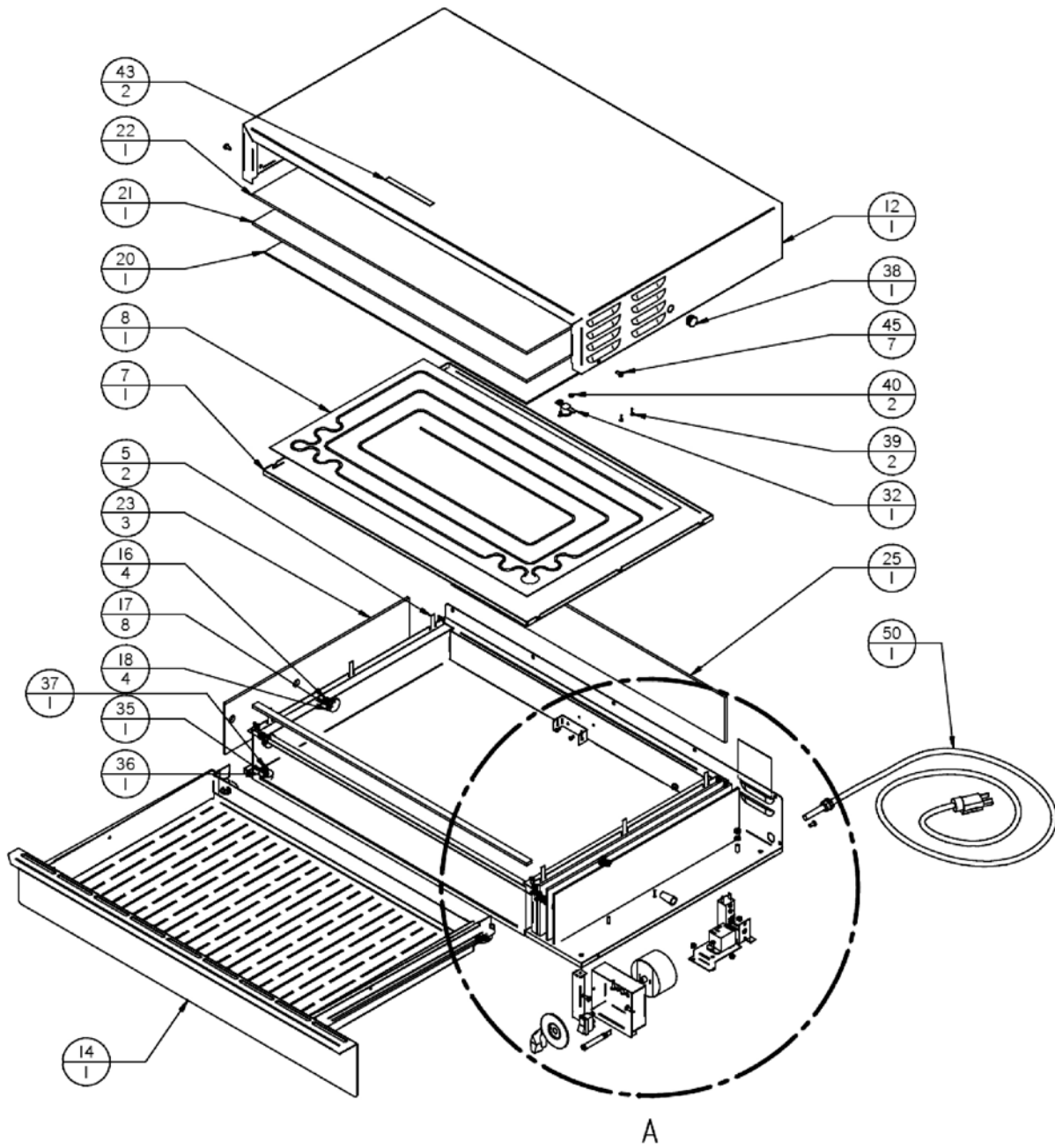

EXPLODED VIEW DETAIL – SPTU

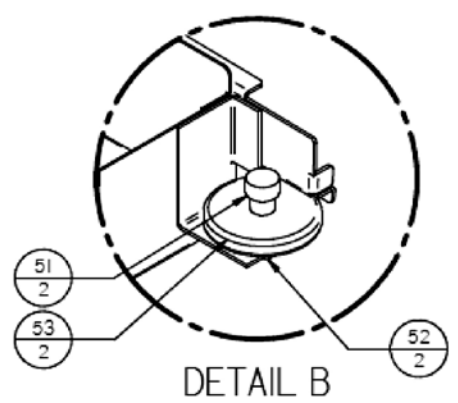
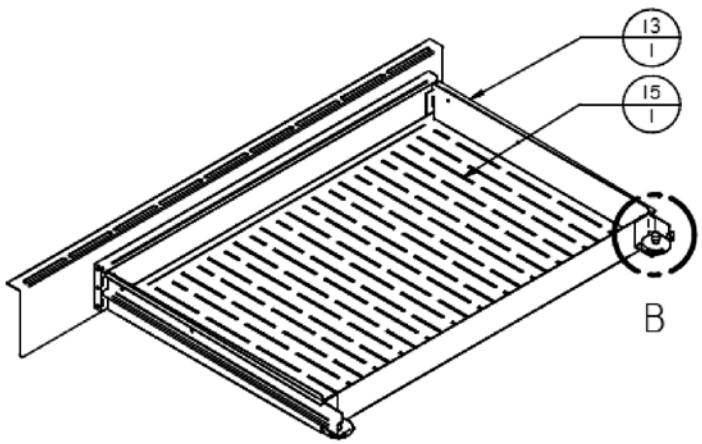
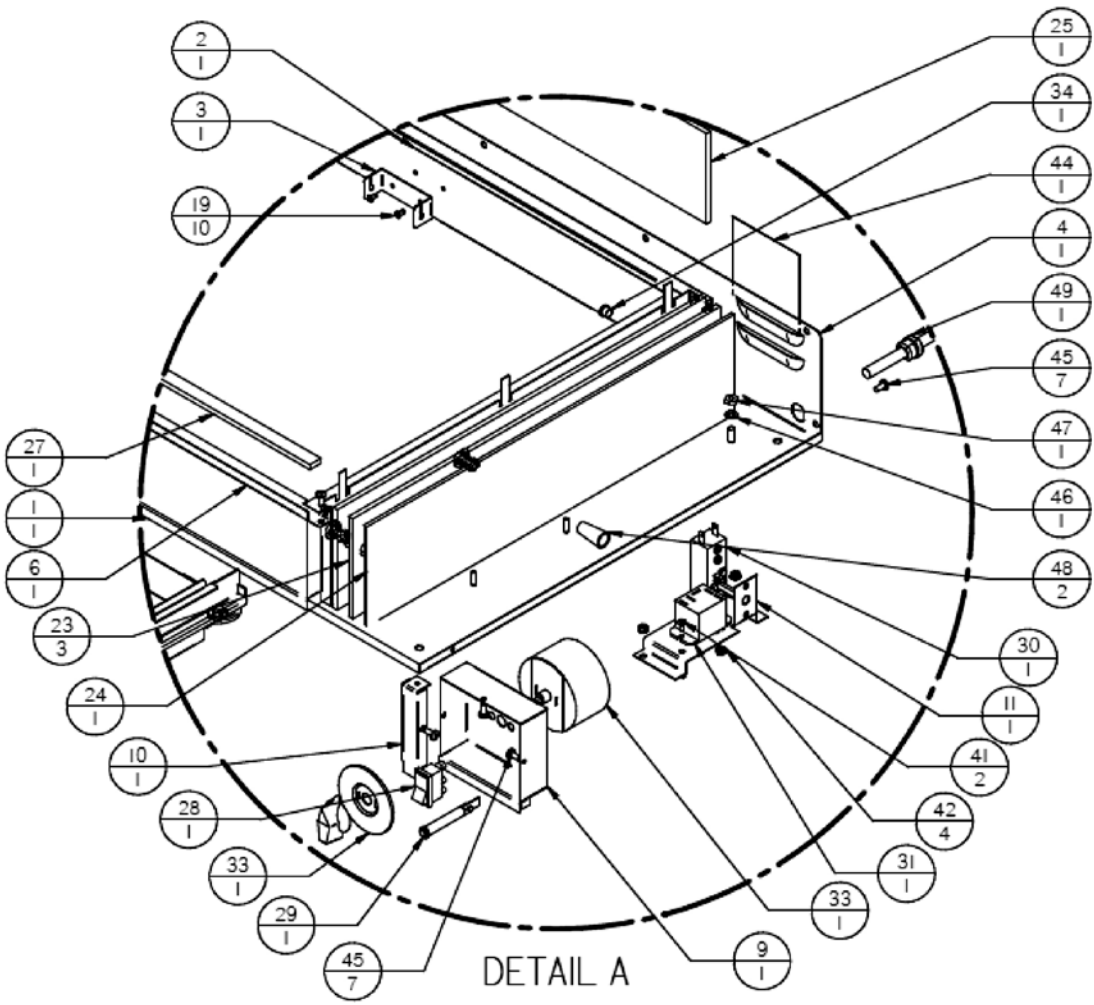

SPTU PARTS LIST

Item	SPTU-50	SPTU-50N	SPTU-30	SPTU-30N	Description	Qty
1	25000157	25000057	25000137	25000037	LINER, INNER	1
2	25000156	25000056	25000136	25000036	LINER, INNER BACK	1
3	25000046	-SAME-	-SAME-	-SAME-	THERMOSTAT BULB BRACKET	1
4	25000155	25000055	25000135	25000035	SKIN, BTM / REAR	1
5	25000064	-SAME-	-SAME-	- SAME -	SUPPORT, SIDE LINER	2
6	25000163	25000063	25000143	25000043	BRACE, FRONT	1
7	25000173	25000073	25000123	25000023	HEAT PLATE, ANODIZED	1
8	25000017 / 25000018	25000015 / 25000016	25000013 / 25000014	25000011 / 25000012	HEATER, FOIL BLANKET 120V / 220V	1
9	25000053	- SAME -	- SAME -	- SAME -	CONTROL PANEL	1
10	25000072	- SAME -	- SAME -	- SAME -	COVER, CONTROL PANEL	1
11	25000076	- SAME -	- SAME -	- SAME -	BRACKET, T-STAT & RELAY	1
12	25000154	25000054	25000134	25000034	SKIN, OUTER / SIDES	1
13	25000160	25000060	25000140	25000040	WELDMENT, DRAWER	1
14	25000165	25000065	25000145	25000045	WELDMENT, DRAWER COVER	1
15	25000169	25000069	25000149	25000049	PAN, DRAWER	1
16	8353200	- SAME -	- SAME -	- SAME -	RIVNUT, 1/4-20 THIN HEAD	4
17	8507600	- SAME -	- SAME -	- SAME -	WASHER, FLAT 1/4"	8
18	8641500	- SAME -	- SAME -	- SAME -	BEARING, STAINLESS ROLLER SLIDES	4
19	8354000	- SAME -	- SAME -	- SAME -	RIVET, POP, 1/8, SS	10
20	25000185	25000085	25000195	25000095	INSULATION, TOP 1	1
21	25000186	25000086	25000196	25000096	INSULATION, TOP 2	1
22	25000187	25000087	25000197	25000097	INSULATION, TOP 3	1
23	25000088	- SAME -	- SAME -	- SAME -	INSULATION, SIDE 1	3
24	25000090	- SAME -	- SAME -	- SAME -	INSULATION, SIDE 3	1
25	25000191	25000091	25000198	25000098	INSULATION, REAR	1
27	25000193	25000093	25000199	25000099	INSULATION, FRONT CHANNEL	1
28	1305610	- SAME -	- SAME -	- SAME -	ROCKER SWITCH	1
29	1513903	- SAME -	- SAME -	- SAME -	LIGHT INDICATOR	1
30	1481510	- SAME -	- SAME -	- SAME -	THERMOSTAT, BULB, 200°F	1
31	1475040	- SAME -	- SAME -	- SAME -	RELAY, SPDT, 120V COIL, 30A @ 240V	1
32	1486410	- SAME -	- SAME -	- SAME -	THERMOSTAT, BI-MET DISC, 125/250V 15/10A	1
33	1400185	- SAME -	- SAME -	- SAME -	TIMER, 60 MIN TIME SWITCH, HIGH TEMP	1
34	8602800	- SAME -	- SAME -	- SAME -	BUSHING, HEYCO B-312-250 NYLON	1
35	8353500	- SAME -	- SAME -	- SAME -	RIVNUT, 8-32 THIN HEAD	1
36	3100742	- SAME -	- SAME -	- SAME -	FEET, BUMPER	1
37	8140800	- SAME -	- SAME -	- SAME -	8-32 x 1/2 MS	1
38	16218-00	- SAME -	- SAME -	- SAME -	PLUG BEAUTY 1/2" CHROME	1
39	8206615	- SAME -	- SAME -	- SAME -	STUD, PEM #4-40 X 3/8	2
40	8400700	- SAME -	- SAME -	- SAME -	NUT, HEX, 4-40, S/S	2
41	8103400	- SAME -	- SAME -	- SAME -	SCREW, MACH, 6-32 X 1/4" LG.	2
42	8400100	- SAME -	- SAME -	- SAME -	NUT, HEX KEPS, #6-32	4
43	8839110	- SAME -	- SAME -	- SAME -	LABEL, CAUTION HOT SURFACE	2
44	8861000	- SAME -	- SAME -	- SAME -	LABEL, SPEC	1
45	8130000	- SAME -	- SAME -	- SAME -	8-32 X 3/8 TYPE T	7
46	8506000	- SAME -	- SAME -	- SAME -	LOCKWASHER, EXT TOOTH # 10	1
47	8422400	- SAME -	- SAME -	- SAME -	#10-24 HX NUT GRN	1
48	1196000	- SAME -	- SAME -	- SAME -	CONNECTOR WIRE SETSCREW #11	2
49	8967400	- SAME -	- SAME -	- SAME -	STRAIN RELIEF	1
50	47255900	- SAME -	- SAME -	- SAME -	CORD SET SJTO 16-3	1
51	8206300	- SAME -	- SAME -	- SAME -	BOLT, SHOULDER .312 DIA. 1/2LG 1/4-20	2
52	8431300	- SAME -	- SAME -	- SAME -	1/4-20 FLANGED HEX LOCKNUT	2
53	25000080	- SAME -	- SAME -	- SAME -	BEARING, LATERAL DRAWER, PTFE	2

WIRING DIAGRAM – HFWAT-2, 2D, 3, 3D, 4, 4D, 5, 5D, 6, 6D

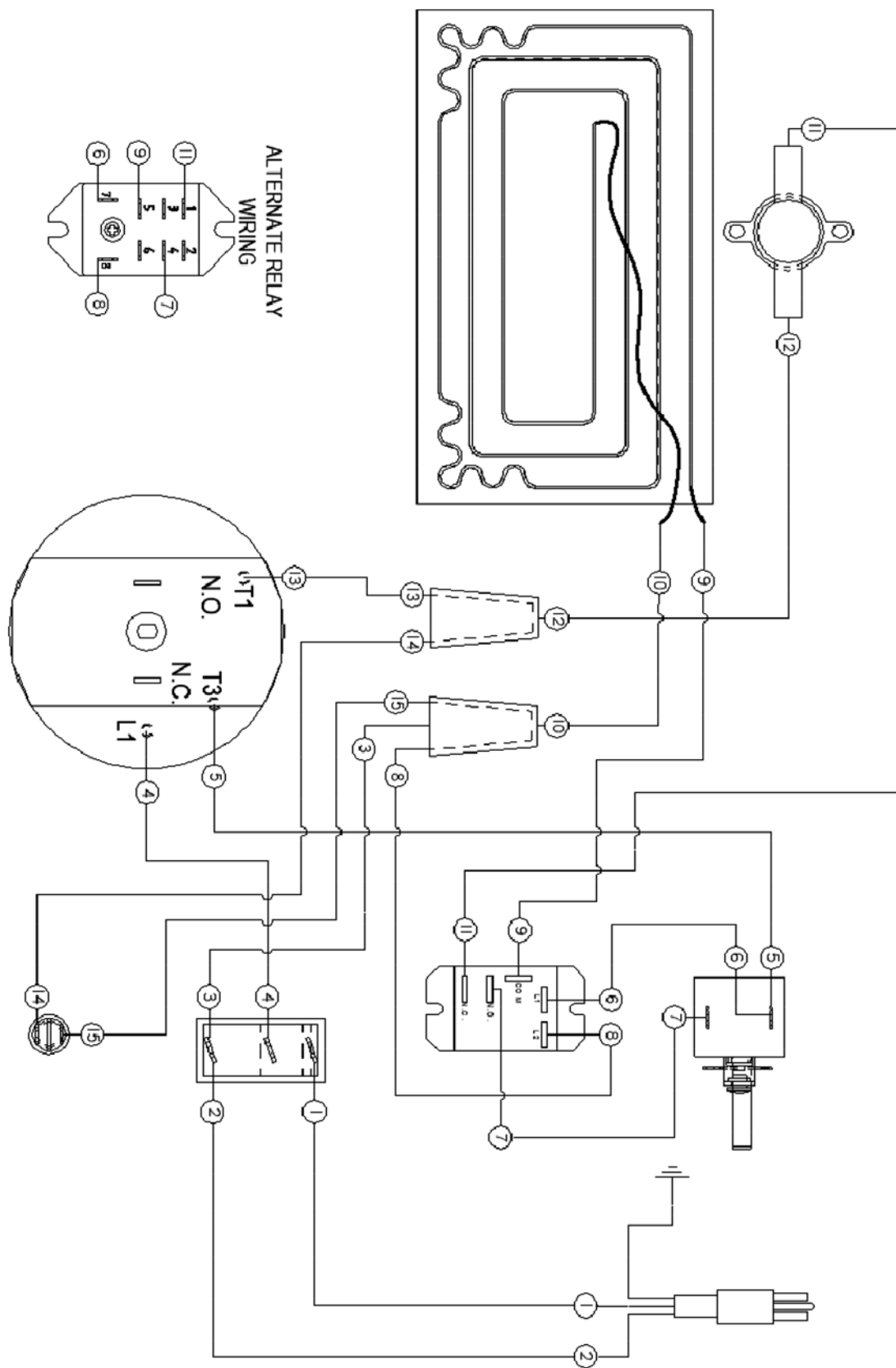

APW Wyott EQUIPMENT LIMITED WARRANTY

APW Wyott Foodservice Equipment Company warrants its equipment against defects in materials and workmanship, subject to the following conditions:

This warranty applies to the original owner only and is not assignable.

Should any product fail to function in its intended manner under normal use within the limits defined in this warranty, at the option of APW Wyott such product will be repaired or replaced by APW Wyott or its Authorized Service Agency. APW Wyott will only be responsible for charges incurred or service performed by its Authorized Service Agencies. The use of other than APW Wyott Authorized Service Agencies will void this warranty and APW Wyott will not be responsible for such work or any charges associated with same. The closest APW Wyott Authorized Service Agent must be used.

This warranty covers products shipped into the 48 contiguous United States, Hawaii, metropolitan areas of Alaska and Canada. There will be no labor coverage for equipment located on any island not connected by roadway to the mainland.

Warranty coverage on products used outside the 48 contiguous United States, Hawaii, and metropolitan areas of Alaska and Canada may vary. Contact the international APW Wyott distributor, dealer, or service agency for details.

Time Period

One year for parts and one year for labor, effective from the date of purchase by the original owner. The Authorized Service Agency may, at their option, require proof of purchase. Parts replaced under this warranty are warranted for the un-expired portion of the original product warranty only.

Exceptions

- * Gas/Electric Cookline: Models GCB, GCRB, GF, GGM, GGT, CHP-H, EF, EG, EHP. Three (3) Year Warranty on all component parts, except switches and thermostats. (2 additional years on parts only. No labor on second or third year.)
- * Broiler Briquettes, Rock Grates, Cooking Grates, Burner Shields, Fireboxes: 90 Day Material Only. No Labor.
- * Heat Strips: Models FD, FDL, FDD, FDDL. Two (2) Year Warranty on element only. No labor second year.
- * Glass Windows, Doors, Seals, Rubber Seals, Light Bulbs: 90 Day Material Only. No Labor.

In all cases, parts covered by extended warranty will be shipped FOB the factory after the first year.

Portable Carry In Products

Equipment weighing over 70 pounds or permanently installed will be serviced on-site as per the terms of this warranty. Equipment weighing 70 pounds or under, and which is not permanently installed, i.e. with cord and plug, is considered portable and is subject to the following warranty handling limitations. If portable equipment fails to operate in its intended manner on the first day of connection, or use, at APW Wyott's option or its Authorized Service Agency, it will be serviced on site or replaced.

From day two through the conclusion of this warranty period, portable units must be taken to or sent prepaid to the APW Wyott Authorized Service Agency for in-warranty repairs. No mileage or travel charges are allowed on portable units after the first day of use. If the customer wants on-site service, they may receive same by paying the travel and mileage charges. Exceptions to this rule: (1) countertop warmers and cookers, which are covered under the Enhanced Warranty Program, and (2) toasters or rollergrills which have in store service.

Exclusions

The following conditions are not covered by warranty:

- * Equipment failure relating to improper installation, improper utility connection or supply and problems due to ventilation.
- * Equipment that has not been properly maintained, calibration of controls, adjustments, damage from improper cleaning and water damage to controls.
- * Equipment that has not been used in an appropriate manner, or has been subject to misuse or misapplication, neglect, abuse, accident, alteration, negligence, damage during transit, delivery or installation, fire, flood, riot or act of god.
- * Equipment that has the model number or serial number removed or altered.

If the equipment has been changed, altered, modified or repaired by other than an Authorized Service Agency during or after the warranty period, then the manufacturer shall not be liable for any damages to any person or to any property, which may result from the use of the equipment thereafter.

This warranty does not cover services performed at overtime or premium labor rates. Should service be required at times which normally involve overtime or premium labor rates, the owner shall be charged for the difference between normal service rates and such premium rates. APW Wyott does not assume any liability for extended delays in replacing or repairing any items beyond its control.

In all cases, the use of other than APW Wyott Authorized OEM Replacement Parts will void this warranty.

This equipment is intended for commercial use only. Warranty is void if equipment is installed in other than commercial application.

Water Quality Requirements

Water supply intended for a unit that has in excess of 3.0 grains of hardness per gallon (GPG) must be treated or softened before being used. Water containing over 3.0 GPG will decrease the efficiency and reduce the operation life of the unit.

Note: Product failure caused by liming or sediment buildup is not covered under warranty.

“THE FOREGOING WARRANTY IS IN LIEU OF ANY AND ALL OTHER WARRANTIES EXPRESSED OR IMPLIED INCLUDING ANY IMPLIED WARRANTY OF MERCHANTABILITY OR FITNESS FOR PARTICULAR PURPOSES AND CONSTITUTES THE ENTIRE LIABILITY OF APW WYOTT. IN NO EVENT DOES THE LIMITED WARRANTY EXTEND BEYOND THE TERMS STATED HEREIN.”

9/05