



RELIABILITY BUILT IN™

Limited One Year Warranty (Commercial Applications)

T&S warrants to the original purchaser (other than for purposes of resale) that such product is free from defects in material and workmanship for a period of one (1) year from the date of purchase. During this one-year warranty period, if the product is found to be defective, T&S shall, at its options, repair and/or replace it. To obtain warranty service, products must be returned to...

*T&S Brass and Bronze Works, Inc.
Attn: Warranty Repair Department
2 Saddleback Cove
Travelers Rest, SC 29690*

Shipping, freight, insurance, and other transportation charges of the product to T&S and the return of repaired or replaced product to the purchaser are the responsibility of the purchaser. Repair and/or replacement shall be made within a reasonable time after receipt by T&S of the returned product. This warranty does not cover items which have received secondary finishing or have been altered or modified after purchase, or for defects caused by physical abuse or misuse of the product, or shipment of the products.

Any express warranty not provided herein, and any remedy for Breach of Contract which might arise, is hereby excluded and disclaimed. Any implied warranties of merchantability or fitness for a particular purpose are limited to one year in duration. Under no circumstances shall T&S be liable for loss of use or any special consequential costs, expenses or damages.

Some states do not allow limitations on how long and implied warranty lasts or the exclusion or limitation of incidental or consequential damages, so the above limitations or exclusions may not apply to you. Specific rights under this warranty and other rights vary from state to state.

Attention California Residents:

⚠ WARNING This product can expose you to chemicals including Lead, Chromium (hexavalent compounds) and Phthalates (DEHP) which are known to the State of California to cause cancer and birth defects or other reproductive harm.

For more information go to
www.P65Warnings.ca.gov.

P/N: 098-003117-45 Rev.2
Date: 11-01-18
Drawn: TEH
Checked: JRM 03-12-19
Approved: JHB 05-29-19

Installation and Maintenance Instructions



Service Sink Faucets

ES

Español:

Instrucciones de instalación y mantenimiento

FR

Français:

Instructions pour l'installation et la maintenance

DE

Deutsch:

Installations- und Wartungsanleitungen

CN

中文:

安装与维护说明

Exploded View

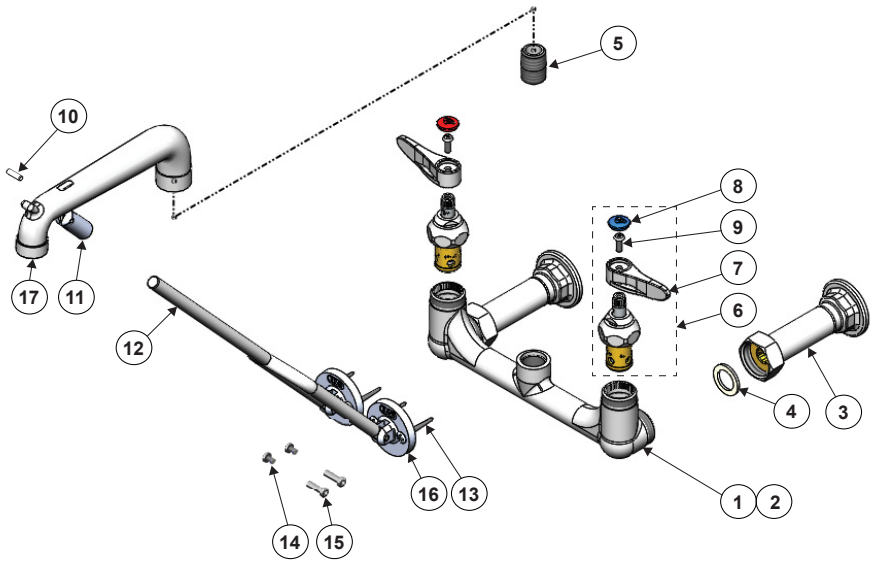

Part Number Guide

Service Sink Faucet Assembly

1	Asm, Base Faucet	B-0650-POL
2	Body, Faucet	N/A
3	Asm, Inlet Extension	B-0441
4	Washer, Coupling Flange	001019-45
5	Nipple, Close 1/2 HWL	002534-25
6	Asm, Eterna w/ Spring Checks & Handle (Cold)	002711-40NS
	Asm, Eterna w/ Spring Checks & Handle (Hot)	002712-40NS
7	Handle, Lever	001638-45NS
	Handle, 4" Wrist Action	B-WH4-NS
8	Index, Button (Red / Hot)	001193-19NS
	Index, Button (Blue / Cold)	018506-19NS
9	Screw, Handle	000925-45
10	Pin, Coiled 3/16" x 5/8 s.s.	001311-45
11	Clevis	000639-25
12	Support Rod	009616-40
13	Screw, Wall Mount	000915-45
14	Screw, Handle	003199-45
15	Nut, Handle	003198-45
16	Flange	003007-40
17	Spout	N/A
	Spout (BSTP)	009545-40

EN

Nozzle Installation:

Note: Nozzle should be installed first. Remove no.6 from both sides of faucet.

1. Apply Loctite #680 to threads of no.5.
2. Thread no.5 into no.17, then rotate no.17 into no.1 until tight with no.17 facing front of sink.

Faucet Installation:

3. Shut off water supply and drain lines. Drill (2) two 7/8" holes in wall or backsplash of sink with 8" centers, where you are installing no.1.
4. Remove no.3 from back of no.1. (No.3 is 1/2" eccentric female)
5. Apply teflon tape or pipe joint compound to threads of water supply lines.
6. Attach no.3 to water supply lines and tighten by hand. (Attach no.1 to no.3, adjusting center to center fit by turning no.3 if needed.) Tighten with a wrench.
7. Screw no.12 into no.11 on bottom side of no.17. Attach no.12 to no.16 by placing no.15 through no.16 and no.12 then screwing no.14 into no.15 and tightening.
8. Drill (4) four 3/16" hole into wall or backsplash where no.12 and no.16 rest against wall. Secure no.16 by screwing no.13 thru no.16 and into wall or backsplash.
9. Turn on water supply and check for leaks.

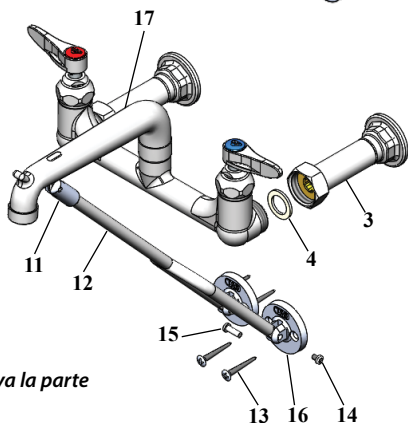
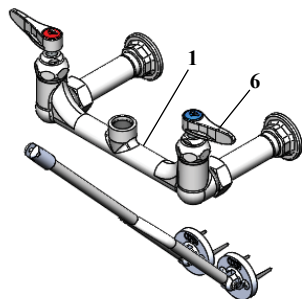
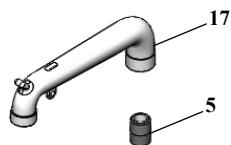

ES

Instalación:

Nota: Las boquillas deben ser instaladas primero. Remueva la parte No.6 de ambos lados de la canilla.

1. Aplique Loctite No. 680 a la rosca de la parte No.5.
2. Enrosque la parte No.5 entre la parte No.17, luego gire la parte No.17 entre la parte No.1 hasta que este apretada, con la parte No.17 orientada hacia el frente de el lavatorio.

Instalación De La Canilla:

3. Cierre la fuente principal de agua y desagüe las tuberías. Perfore (2) dos huecos de 2cm de diámetro en la pared o en el espaldar del lavatorio con centros de 20cm, donde la parte No.1 será instalada.
4. Remuévala la parte No.3 de la parte posterior de la parte No.1 (No.3 es rosca femenina de 1.25cm excéntrica)
5. Aplique cinta para rosca de tubería o compuesto de coyuntura a las líneas del surtido de agua.
6. Junte la parte No.3 a las líneas del surtido de agua y aprete a mano. (Junte la parte No.1 a la No.3,ajustando la medida de centro a centro girando la parte No.3 si es necesario.) Apreté con una llave.
7. Atornille la parte No.12 entre la No.11 en el lado de abajo de la parte No.17. Junte la parte No.12 a la parte No.16 colocando la parte No.15 a través de las partes No.16 y No.12 luego atornillando la parte No.14 en la No.15 y apretela.
8. Perfore (4) cuatro huecos de .5cm en la pared o el espaldar donde las partes No.12 y 16 hagan contacto. Asegure la parte No.16 atornillando la parte No.13 a través de la parte No.16 dentro de la pared o el espaldar.
9. Abra la fuente de agua e inspeccione por filtraciones.



L'Installation De L'Ajutage:

Noter: Les ajutages doivent être installés au début. Enlever N°.6 de chaque côté du robinet.

1. Appliquer "loctite #680" aux filets de N°.5.
2. Mettre N°.5 à travers N.17, puis tourner N.17 dans N.1 jusqu'à ce qu'il soit bien serré avec N.17 vers la face de l'évier.

L'Installation Du Robinet:

3. Fermer la réserve de l'eau et égoutter la tuyauterie. Percer (2) deux trous 2cm, avec un diamètre de 3cm dans le mur ou le garde-boue de l'évier avec les centres de 20cm, où vous allez installer N°.1.
4. Enlever N°.3 de la partie arrière de N°.1.(N°.3 être 1.5cm femelle excentrique).
5. Appliquer le ruban en Téflon ou le composé pour les tuyaux aux filets des tuyaux qui fournissent l'eau.
6. Attacher N°.3 aux tuyaux qui fournissent l'eau et resserrer par la main. (Attacher N°.1 à N°.3 en réglant centre à centre en tournant N°.3 si nécessaire). Resserrer avec une clef.
7. Visser N°.12 dans N°.11 sur le côté arrière de N°.17. Attacher N°.12 à N°.16 en plaçant N°.15 à travers N°.16 et N°.12. Puis visser N°.14 dans N°.15 et resserrer.
8. Percer (4) quatre trous 9cm dans le mur ou le garde-boue de l'évier où N°.12 et N°.16 resteront contre le mur. Attacher N°.16 en vissant N°.13 à travers N°.16 dans le mur ou le garde-boue.
9. Recommencer l'eau et vérifier s'il y a des fuites.



Schwenkhahninstallation:

Anmerkung: Die Schwenkhähne sind als erstes zu installieren. Nr.6 von beiden Seiten des Schwenkhahns entfernen.

1. Loctite Nr. 680 auf das Gewinde von Nr.5 auftragen.
2. Nr.5 durch Nr.17 führen, dann Nr.17 in Nr.1 drehen, bis Nr.17 festsetzt, wobei Nr.17 auf die Vorderseite des Spültisches auszurichten ist

Armatureninstallation:

3. Wasserzufuhr abstellen und Leitungen entleeren. Zwei (2) 2,25cm große Löcher mit einem Durchmesser von ungefähr 3cm in die Wand oder den Spritzschutz bohren mit einer Mitte von 20cm, in die Nr.1 installiert wird.
4. Nr.3 von der Rückseite von Nr.1 entfernen (Nr.3 ist das 1,25cm große Exzentrentventil).
5. Teflonband oder Rohrdichtmasse auf das Gewinde der Wasserzufuhrleitungen auftragen.
6. Nr.2 mit der Wasserzufuhr verbinden und mit der Hand anziehen. (Nr.1 mit Nr.3 verbinden, die beiden Mittelpunkte aufeinander ausrichten, indem Nr.3, falls erforderlich, gedreht wird.) Mit einem Schraubenschlüssel festdrehen.
7. Auf der Unterseite von Nr.17 Nr.12 in Nr.11 einschrauben. Nr.12 auf Nr.16 anbringen, indem Nr.15 durch Nr.16 und Nr.12 gesteckt wird und dann Nr.14 in Nr.15 eingeschraubt und festgezogen wird.
8. Wo Nr.12 und Nr.16 auf der Wand aufliegen, vier (4) 0,5cm Löcher in die Wand oder den Spritzschutz bohren. Nr.16 befestigen, indem Nr.13 durch Nr.16 in die Wand oder den Spritzschutz geschraubt wird.
9. Wasserzufuhr andrehen und auf Lecks prüfen.



水嘴安装:

注意: 水嘴应最先安装, 把6号从龙头的两边拆除

1. 在5号的螺纹上缠上生料带
2. 把5号拧到17号上, 后将17号转入1号, 直至拧紧后17号正对水槽前方

龙头安装:

3. 关闭水管供水，找准预计安装**1号**的位置后，在墙面或水槽背板上钻2个7/8" (22 mm)的孔，中心距为8" (203 mm)
4. 把**3号**从**1号**的背面拆下，（**3号**为1/2" 偏心内螺纹）
5. 在水管上缠上生料带
6. 将**3号**连到供水管上并用手拧紧，（将**1号**连在**3号**上，如有需要，可通过旋转**3号**使中心对齐）用扳手拧紧
7. 将**12号**拧入位于**17号**底部的**11号**上，把**12号**装到**16号**上，将**15号**穿入**16及12号**，然后把**14号**拧到**15号**上并拧紧
8. 确定需要安装**12号**跟**16号**的位置，在墙面上或背板上钻4个3/16" 的孔，将**13号**穿过**16号**并拧紧在墙面或背板上以固定住**16号**
9. 打开供水并检查是否漏水

RELATED T&S BRASS PRODUCT LINE

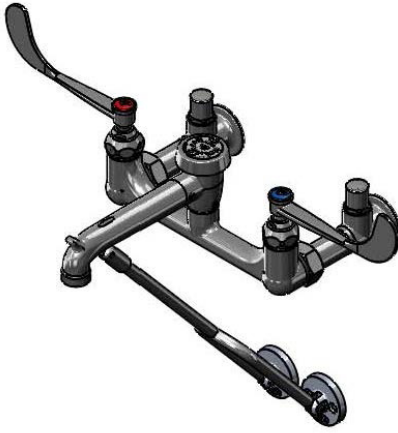

B-0657
Service Sink /
Mop Sink Faucet

B-0674-RGH
Service Sink /
Mop Sink Faucet

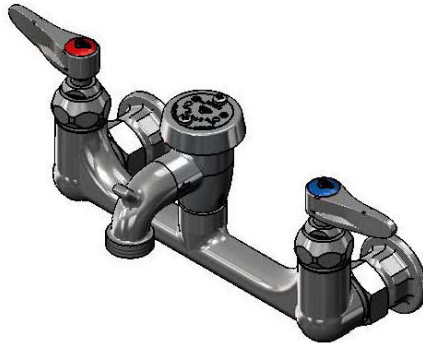

T&S BRASS AND BRONZE WORKS, INC.

A firm commitment to application-engineered plumbing products

2 Saddleback Cove, P.O. Box 1088,
Travelers Rest, SC 29690

Phone: (864) 834-4102

Fax: (864) 834-3518

E-mail: tsbrass@tsbrass.com

T & S Brass-Europe
'De Veenhoeve'
Oude Nieuwveenseweg 84
2441 CW Nieuwveen

The Netherlands



RELIABILITY BUILT IN™