

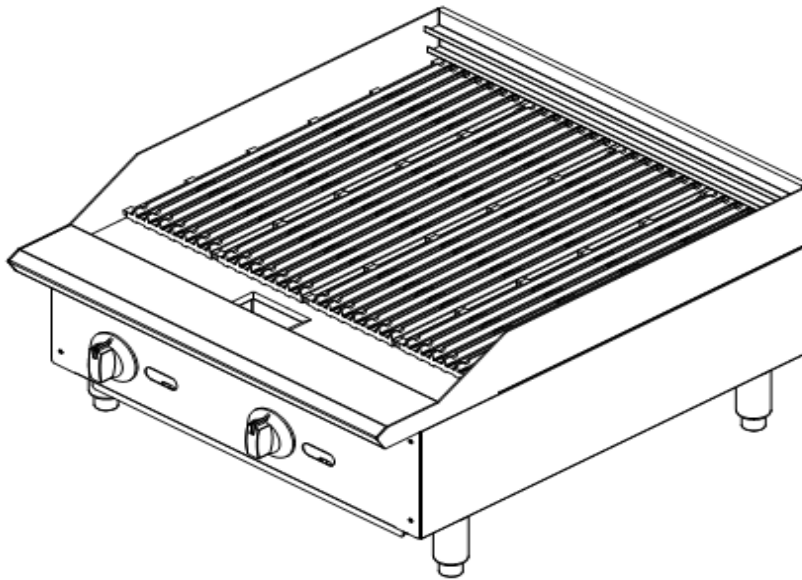

GAS CHAR-BROILER MANUAL
MODELS: MBR24/MBR36/MBR48



This manual contains important information regarding your MOTAK unit. Please read the manual thoroughly prior to equipment set-up and operation maintenance. Failure to comply with regular maintenance guidelines outlined in the manual may void the warranty. Improper installation, adjustment, alteration, service or maintenance can cause property damage, injury or death. Read this manual thoroughly before installing or servicing this equipment.

MUST READ!



WARNING:



This product contains chemicals known to the State of California to cause cancer and birth defects or other reproductive harm.

For more information: www.P65Warnings.ca.gov

SAFETY PRECAUTIONS

Before installing and operating this equipment, be sure everyone involved in its operation is fully trained and aware of precautions. Accidents and problems can be caused by failure to follow fundamental rules and precautions.

The following symbols, found throughout this manual, alert you to potentially dangerous conditions to the operator, service personnel, or to the equipment.

	<p>This symbol refers to a potential hazard or unsafe practice that could result in injury or death.</p>
	<p>This symbol refers to a potential hazard or unsafe practice that could result in injury, product damage, or property damage.</p>
	<p>This symbol refers to information that needs special attention or must be fully understood, even though not dangerous.</p>

FOR YOUR SAFETY TO AVOID SERIOUS PERSONAL INJURY AND PROPERTY DAMAGE:

- **ALWAYS** install equipment in a work area with adequate light and space.
- **ONLY** operate on a solid, level, nonskid surface that is nonflammable and away from sinks and water hazards.
- **NEVER** bypass, alter, or modify this equipment in any way from its original condition. Doing so may create hazards and will void warranty.

 <p>FIRE HAZARD FOR YOUR SAFETY</p> <p>Do not store or use gasoline or other flammable vapors and liquids in the vicinity of this or any other appliance. Keep area around appliances free and clear of combustibles. Purchaser of equipment must post in a prominent location, detailed instructions to be followed in the event the operator smells gas. Obtain the instructions from the local gas supplier</p>

 <p>MOTAK Char Broilers are intended for commercial use only. Not for household use. Warranty will be void if service work is performed by other than an authorized technician, or if other than genuine MOTAK replacement parts are installed. Be sure this Operator's/Installer's Manual and important papers are given to the proper authority to retain for future reference.</p>
--

**For warranty Service on your MOTAK Gas Counter Char Broiler
call 833-474-0367
Be sure to have your model and serial number when calling.**

Congratulations! You have purchased one of the finest pieces of commercial cooking equipment on the market. You will find that your new equipment, like all MOTAK equipment, has been designed and manufactured to meet the toughest standards in the industry. Each piece of MOTAK equipment is carefully engineered and designs are verified through laboratory tests and field installations. With proper care and field maintenance, you will experience years of reliable, trouble-free operation. For best results, read this manual carefully.

RETAIN THIS MANUAL FOR FUTURE REFERENCE

Table of Contents

Specifications-----	Page 4
Installation-----	Page 5
Start Up Instructions -----	Page 8
Seasoning-----	Page 9
Operating the Char Broiler -----	Page 9
Cleaning Instructions -----	Page 10
Service/Trouble Shooting-----	Page 11
Parts-----	Page 12

Read these instructions carefully before attempting installation. Installation and initial startup should be performed by a qualified installer. Unless the installation instructions for this product are followed by a qualified service technician (a person experienced in and knowledgeable of the installation of commercial gas and/or electric cooking equipment) then the terms and conditions on the Manufacturer's Limited Warranty will be rendered void and no warranty of any kind shall apply.

GAS and GAS PRESSURE

⚠ CAUTION This appliance is factory supplied in Natural Gas. This unit can be converted to LPG gas by a licensed and certified gas technician. Documentation may be necessary for warranty issues. Failure to comply with this instruction will void warranty. **See the included LPG conversion kit for gas conversion parts and instructions.**

⚠ WARNING Appliance installation must conform to the National Fuel Gas Code, ANSI Z223.1/NFPA 54, the National Gas Installation Code, CSA-B149.1, or the Propane Installation Code, CSA-B149.2 as applicable and in accordance with local codes.

⚠ WARNING The appliance and its individual shutoff valve (to be supplied by user) must be disconnected from the gas supply piping system during any pressure testing of that system at test pressures in excess of 1/2" P.S.I. (3.45kPa).

This product is designed, built, and sold for commercial use only.

Instructions must be posted in a prominent location. All safety precautions must be taken in the event the user smells gas. Safety information can be obtained from your local gas supplier.

SPECIFICATIONS

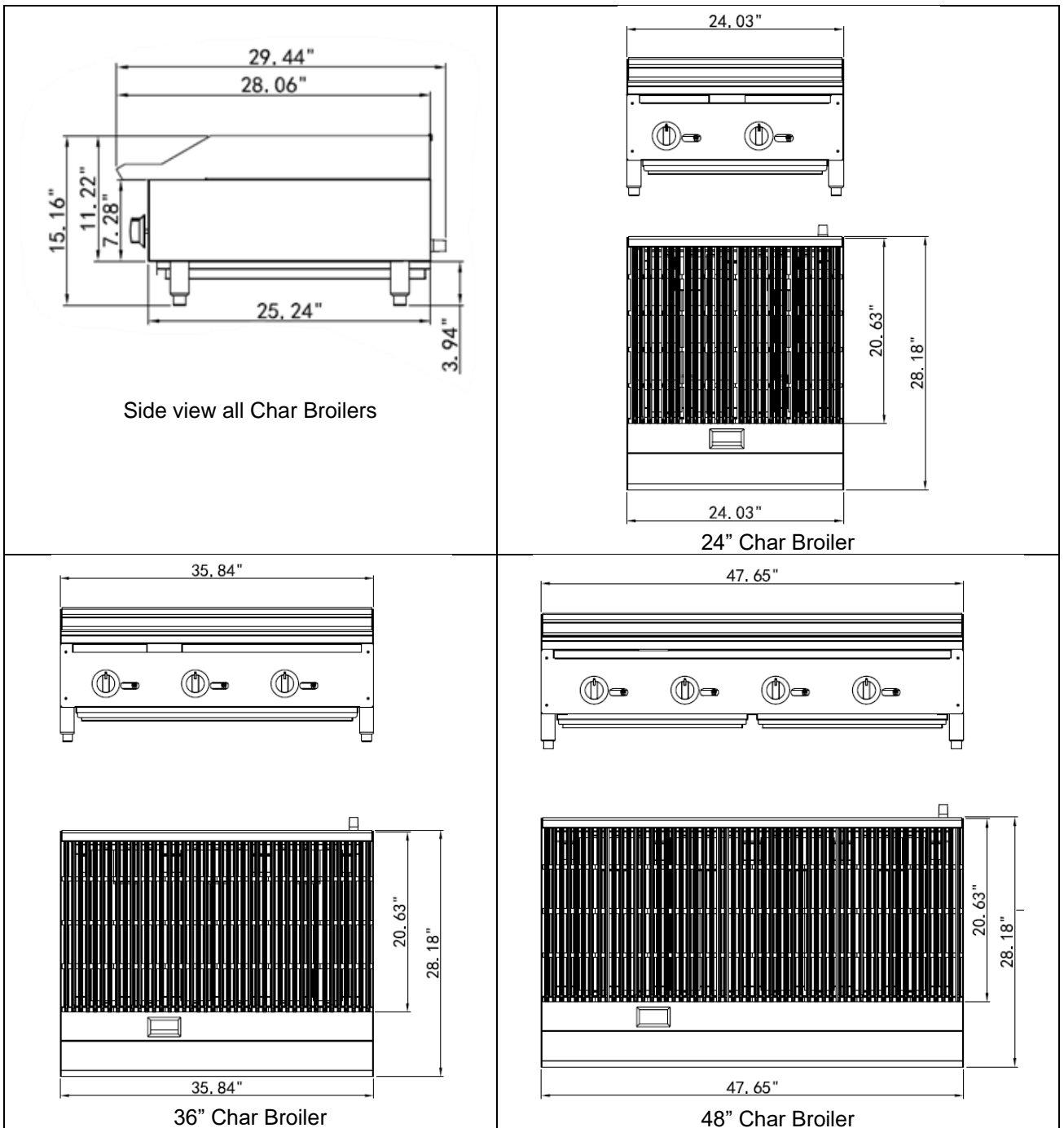

Model	Description	BTU.hr	Number of Burners	Gas Type
MBR24	Gas Char Broiler 24"	70,000	2	Natural Gas or Propane*
MBR36	Gas Char Broiler 36"	105,000	3	Natural Gas or Propane*
MBR48	Gas Char Broiler 48"	140,000	4	Natural Gas or Propane*

*Shipped setup for Natural Gas and includes a kit for conversion to Propane Gas

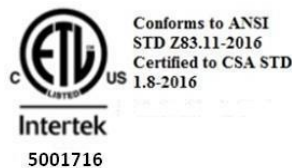

UNPACKING

Unpack the Char Broiler immediately after receipt. Remove the Char Broiler from the crate; remove all packaging on and surrounding the unit and be certain to remove all protective plastics and residues from all surfaces. Make sure that all parts provided including the LPG gas conversion kit are located. Equipment must have the legs properly installed before use. Before using this equipment, it must be cleaned and dried thoroughly.

INSTALLATION

1. Read this manual thoroughly before installation and operation. **DO NOT** proceed with installation and operation if you have any questions or do not understand anything in this manual. Contact your local representative or MOTAK first.
2. Select a location for the Char Broiler that has a level, solid, nonskid surface that is nonflammable and away from water hazards or sinks, and is in a well-lighted work area away from children and visitors.
3. This equipment must be installed under proper ventilation as required by local code.

NOTICE:

Local codes regarding installation and ventilation vary greatly by area. The National Fire Protection Association states in its NFPA 96 latest edition (see NFPA page at the beginning of this manual) that local codes are “authority having jurisdiction” when it comes to requirements for installation of equipment. Therefore, installation should comply with all local codes.

4. Screw legs into the permanently fastened nuts on the four corners of the unit and tighten by hand. Legs must be installed to adequately provide proper ventilation to the unit. **DO NOT INSTALL WITHOUT LEGS!**
5. Level unit by adjusting the four feet and tighten securely. The adjustable feet have an adjustment of one inch. Do not slide unit with legs mounted, lift if necessary to move unit.
6. The supplied gas pressure regulator is factory set at 4” Natural Gas W.C. or 10” Propane Gas
7. **THESE UNITS ARE SUITABLE FOR INSTALLATION ON NON-COMBUSTIBLE SURFACE ONLY.** Zero (0) clearance from NON Combustible.
8. Do not obstruct the flow of combustion and ventilation air under the unit by the legs or behind the unit by the flue. Do not place objects between the bottom of the unit and the counter top.
9. There must be adequate clearance for removal of the front panel. All major parts except the burners are removable through the front if the gas is disconnected.
10. It may be necessary to adjust the balance of gas volume and air supply to each burner. This must be done by an authorized service technician.
11. Pipe threading compound must be resistant to the action of liquefied petroleum gas. **DO NOT USE TEFLON TAPE.**

WARNING

DO NOT use an open flame to check for leaks. Check all gas piping for leaks with a soap and water solution before operating the unit

12. **Checking For Gas Leaks:** Using a gas leak detector or a soapy water solution is recommended for locating gas leaks. Matches, candle flame or other sources of ignition shall not be used for this purpose. Check entire piping system for leaks.
13. **Manual Shut Off Valve:** A manual shut off valve should be installed upstream from the manifold, within four (4) feet, (1.2M) of the appliance and in a position where it can be reached in the event of an emergency.
14. Gas piping shall be of such size and so installed as to provide a supply of gas sufficient to meet the full gas input of the appliance. If the appliance is to be connected to existing piping, it shall be checked to determine if it has adequate capacity. Joint compound (pipe dope) shall be used sparingly and only on the male threads of the pipe joints. Such compounds must be resistant to the action of Liquefied Propane (LPG) gases.

The installation of this appliance must conform to local codes, or in the absence of local codes, the National Fuel Gas Code, ANSI Z223.1/NFPA 54, or the Natural Gas and Propane Installation Code, CSA B149.1, as applicable.

- The appliance and its individual shut off valve must be disconnected from the gas supply piping system during any pressure testing of that system at test pressures in excess of ½ PSI (3.5kPa).
- The appliance must be isolated from the gas supply piping system by closing its individual manual shut off valve during any pressure testing of the gas supply piping system at test pressures equal to less than ½ PSI (3.5kPa).

Clearance and positioning around the appliance: This appliance can be installed adjacent to non-combustible surfaces only with zero (0) clearance. A minimum spacing of six (6”) inches from all sides and rear from combustible surfaces. The appliance must have the supplied four (4”) inch legs installed and be placed on a non-combustible surface.

Air supply and ventilation: The area in front and around the appliances must be kept clear to avoid any obstruction of the flow of combustion and ventilation air. Adequate clearance must be maintained at all times in front and at the sides of the appliance for servicing and proper ventilation.

Pressure Regulator: This commercial appliance comes with a convertible pressure regulator to insure proper and efficient operation. The pressure regulator provided is adaptable for both Natural and LPG gas. Regulator specifications: ¾” NPT inlet and outlet, preset for four-inches (4”) WC Natural Gas and may be converted by qualified personnel to be used for LPG at ten-inches (10”) WC.

Prior to connecting the regulator, check the incoming line pressure. The regulator can only withstand a maximum pressure of ½ PSI (13” WC). If the line pressure is beyond this limit, a step-down regulator before the regulator provided will be required. The arrow forged into the bottom of the regulator body shows gas flow direction, and should point downstream to the appliance.

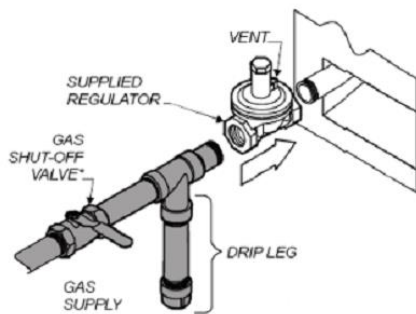

Connection diagram

Gas Conversion: Conversion from Natural Gas to Liquefied Propane (LP) or vice versa may only be performed by the factory or its authorized service agent. In the case of troubleshooting, ensure that the correct orifice sizes of the spuds have been provided.

Natural Gas Orifice	#33 dms
Liquefied Propane (LP) Orifice	#49 dms

NOTE: The orifice size is marked on the spud.

CAUTION: Any loose dirt or metal particles, which are allowed to enter the gas lines on this appliance, will damage the valve and affect its operation. When installing this appliance, all pipe and fittings must be free from any internal contaminants. It is recommended that a “drip leg” be installed in-line before the regulator.

Gas Connection: The appliance comes fitted with a ¾” NPT (National Pipe Thread) connection to the pressure regulator.

⚠ WARNING

FIRE DEATH HAZARD

If you smell gas follow the instructions provided by the gas supplier. Do not touch any electrical switch; do not try to light the burner; do not use a telephone within close proximity.

Maintenance: A qualified service company should check the unit for safe and efficient operation on an annual basis. Contact the factory representative or local service company to perform maintenance and repairs.

Exhaust Canopy: Char Broilers inherently create a good deal of heat and smoke and should be installed under an efficient exhaust hood with flame proof filters. A vertical distance of not less than four (4) feet shall be provided between the top of the appliance and filters or any other combustible material.

Lighting the Pilot: The Char Broiler is equipped with a standing pilot for each burner and each pilot should be lit immediately after the gas is supplied to the appliance.

1. Before attempting to light pilots, turn off the main gas valve to the appliance and wait five (5) minutes to clear the gas.
2. Turn off all gas control knobs (E). See figure 1 on Page 9.
3. Turn on main gas valve and light all pilots.
4. The pilot burner must be lit at the end of the tube. Hold an ignition source through the pilot light hole (D, Fig 1) in the front panel at the pilot tube. When the flame is established remove ignition source.
5. To shut down the appliance, turn off the main gas valve to the appliance.

NOTE: Smoke appearing on initial use of the appliance is normal. This is a result of the rust preventative coating burning off. This will occur for at approximately fifteen (15) minutes during the first use or seasoning process.

Pilot Flame Regulation: The pilot flame on the appliance has been factory adjusted. When adjustment is necessary, adjust the pilot flames as small as possible, but high enough to light the burner immediately when burner valve is turned to the "HIGH" setting. Access to the pilot flame adjustment screw is obtained by removing the front panel. (See "D" Fig 1)

Burner Adjustment: Remove the front panel to gain access. Turn burner valve knob to "HIGH" position. Slowly decrease mixing ring aperture to give a soft blue flame having luminous tips, then slowly increase opening to a point where the yellow tips disappear and a hard-blue flame is obtained.

ALWAYS SAFETY FIRST!

⚠️WARNING Improper installation, adjustment, alteration, service or maintenance can cause property damage, injury or death. Read the installation, operating and maintenance instruction thoroughly before installing or servicing this equipment.

⚠️WARNING FIRE, INJURY or DEATH HAZARD
This equipment must be installed by a qualified installer in accordance with all federal, state and local codes. Failure to install this equipment properly can result in injury or death.

⚠️WARNING FIRE and INJURY or DEATH HAZARD
Injuries or death can occur if this equipment is not used properly. To reduce risk of injury or death:

- Keep the appliance area free and clear from combustibles
- Do not obstruct the flow of combustion and ventilation air
- Do not spray controls or the outside of the appliance with liquids or cleaning agents
- Let hot appliance cool before cleaning or moving
- The appliance should only be used in a flat, level position
- Do not operate unattended

⚠️WARNING FIRE HAZARD
Do not install or use without the 4" legs. Use of this appliance without legs can cause the appliance to overheat and cause fire.

IMPORTANT SAFEGUARDS & SAFETY INSTRUCTIONS

⚠ CAUTION When using gas cooking equipment, basic safety precautions should always be followed, including the following:

The Char Broiler outside surfaces may become HOT after use. Use caution when touching the unit.

- Never directly touch the cooking surface while the Char Broiler is on.
- Always turn off the unit when not in use, servicing or adjusting any parts or attachments, and before cleaning.
- Never leave the Char Broiler on overnight.
- Do not operate any equipment with a damaged or leaking gas line, pilot, or valve or if the unit is dropped or damaged in any manner. Call for Service.
- The use of attachments not recommended or sold by the manufacture may cause fire, injury or even death.
- **DO NOT USE OUTDOORS.**
- Do not use this equipment for any use other than the use intended by the manufacturer.
- Never use the Char Broiler as a heating source.
- The Char Broiler does not contain **any** user-serviceable parts. Dealer or recommended qualified technicians should carry out repairs. Do not remove any components or service panels on this product.
- Never bypass, alter, modify, or attach any unauthorized parts to this equipment. Doing so may create a hazard and will void warranty.
- We take every care to ensure that all products are safe. Steel cutting procedures used to manufacture these items, result in sharp edges. These sharp edges are removed to the best of our ability; however, we insist the operator take care when in contact with this piece of equipment.
- Always keep hands, hair, and clothing away from heating source.
- Allow the Char Broiler to cool down after use and before dismantling for cleaning; the unit will be too hot to handle immediately after use.
- **DO NOT USE ICE TO COOL DOWN THE CHAR BROILER GRATES.** This will cause the Char Broiler Grate to warp/crack and render it unusable.

START UP INSTRUCTIONS

Starting up the Char Broiler – Pilot Lighting Instructions

Before operating the Char Broiler, it should be checked to see that it is sitting level. Adjust the feet to level the Char Broiler. Be sure the catch tray has been properly placed.

The pilot light on the appliance has been set at the factory. Each burner has a pilot light.

1. Make sure all knobs are in the “OFF” position.
2. The main gas valve should be “CLOSED/OFF” for five (5) minutes prior to lighting pilots to clear any existing gas. (Main gas valve is supplied by others.)
3. Turn “ON” or “OPEN” the main gas valve to the unit.
4. Light and hold an ignition source (match) at the pilots. When the flame is established, remove the ignition source. Repeat this step for each burner as each burner has its own individual pilot. The pilot can be reached through the holes in the front of the unit.
5. Turn each burner knob “ON”. If the burners do not ignite promptly, turn the knobs “OFF”. From the opening in the front panel, use a screwdriver and turn the pilot valve screw counterclockwise, which will increase the flame height and repeat step 4.

If the pilot flame appears larger than necessary, turn it down and retest the burner ignition. The pilot flame should be as small as possible but large enough to guarantee reliable ignition of the burners when the knobs are turned to “ON”. In the holes located in the front panel are pilot valve adjustments. Use a screwdriver to turn the valve to adjust the flame height to your desired level.

⚠ CAUTION All burners are lit from constantly burning pilots. Turning the valve to the desired flame height is all that is required to put the unit into service.

OPERATING INSTRUCTIONS (Continued)

Igniting the Burner

To ignite the burner, turn knob to the "ON" position, then back off to the desired flame level. The range of adjustment is virtually infinite between "ON" and "OFF". The space between the legs at the bottom admits combustion air. DO NOT BLOCK THIS SPACE.

Do not permit fans to blow directly at the unit. Whenever possible, avoid open windows next to the unit's sides or back. Avoid wall type fans which create air cross-currents within a room.

It is also necessary that sufficient air should be allowed to enter the room to compensate for the amount of air removed by any ventilation system. Otherwise, a subnormal atmospheric pressure will occur, affecting operation and causing undesirable working conditions.

A properly designed and installed hood will act as the heart for the ventilation system for the room or area in which the unit is installed, and will leave the unit independent of changing draft conditions.

NOTE: It may be necessary to adjust the balance of gas, volume, and air supply to each burner. This must be done by an authorized service technician.

SEASONING THE CHAR BROILER

Be sure to start with a clean Char Broiler surface. Pour a small amount of high quality cooking oil onto a clean cloth about one ounce (30 cc) per square foot of surface. Spread the oil (thin coat) over the entire Char Broiler Grate. NOTE: Do not use excessive oil, just a small amount. Turn on the Char Broiler to the lowest flame height and allow to heat for approximately 30 minutes. The broiler grids are now ready for use.

Note: Each time the Char Broiler is cleaned with **soap and water**, the seasoning is removed and this process must be repeated.

OPERATING THE CHAR BROILER

Turn the burners on about 15-20 minutes before cooking for preheating. Set the knobs to the desired flame height or temperature.

Each valve controls the gas flow to the burner to bring that area of the Char Broiler up to the desired temperature. If different temperature settings are to be used, adjoining areas should be set to a progressively higher temperatures using the lowest temperature on the outside burners. A uniform and systematic approach to the loading of the unit will produce the most consistent product results.

Figure 1.

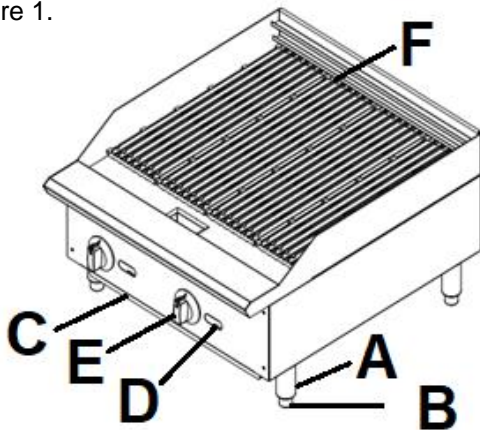

- A. LEG. Supports the Equipment
- B. ADJUSTABLE FEET. Used to adjust the level of the equipment.
- C. DRIP TRAY. A tray that collects grease and oil. This tray can be removed for cleaning
- D. PILOT LIGHT ACCESS HOLE. Allows access to the pilot light.
- E. GAS CONTROL KNOB. Used to set or adjust the temperature of the grilling surface.
- F. CHAR BROILER GRATE. Cooking Surface

CLEANING INSTRUCTIONS

⚠ CAUTION

- **DO NOT** use any abrasive or flammable cleaning fluids.
- **DO NOT** hose down, immerse, or pressure wash any part of the Char Broiler, excluding the catch tray.
- **NEVER** use a scrubber pad (on all exterior surfaces, except the Char Broiler grate), steel wool or abrasive material, or cleaners containing chlorine, iodine and ammonia, or bromine chemicals as these will deteriorate the stainless steel and shorten the life of the unit.

⚠ CAUTION IF CLEANING ALL THE CHAR BROILER'S SURFACES, THE MAIN GAS VALVE MUST BE SWITCHED TO THE CLOSED POSITION. AFTER CLEANING, THE GAS LINE CAN BE SWITCHED BACK TO THE OPEN POSITION. PLEASE FOLLOW THE LIGHTING INSTRUCTION IN THE MANUAL TO RELIGHT THE BROILER'S PILOT LIGHTS AS NEEDED.

Recommended Cleaning

It takes very little time and effort to keep the Char Broiler attractive and performing at top efficiency. Wait until the Char Broiler is cool after the unit had been turned off. Please follow the cleaning steps below:

PART	REQUIRED ACTION	FREQUENCY
Body	Use a clean cloth and a non-abrasive cleaner to clean the stainless steel body of the Char Broiler. Wipe the polished areas with a soft cloth.	Daily
Back and Side Splashes	Thoroughly clean. Wipe with clean, warm mildly soapy water then re-wipe splashes with a damp cloth.	Daily
Controls	Unit should be turned off when not in use. It is recommended that the unit be disconnected from the gas supply by closing the main gas valve. Use a clean cloth to wipe any grease or debris from the control knobs.	Daily
Char Broiler Grids	Clean surface with a grill brush or metal scrapper. <ul style="list-style-type: none"> • Remove cooking grids from the Char Broiler. Place in a sink or cleaning tub. • Clean the Char Broiler surface thoroughly. If necessary, use a wire brush. • Wash with mild soap and warm water. • Remove all soap and debris thoroughly; wipe with a clean, damp cloth. • The cooking grates should then be covered with a thin film of oil to prevent rusting. • Clean stainless surfaces with a damp cloth and polish with a soft dry cloth. To remove discoloration, use a nonabrasive cleaner. • After each "weekly" cleaning, the Char Broiler must be seasoned again. If the Char Broiler usage is very high, the "weekly" cleaning procedures may be done more often than once a week. The use of ice on the Char Broiler Grate to cool may damage the Grate. 	Daily & Weekly
Catch Tray	Once the unit has cooled, remove the catch tray and discard the waste, grease, debris, and crumbs. CAUTION: If the catch tray is permitted to fill too high, grease/debris is likely to accumulate under the unit. This catch tray/drawer is removed by pulling forward. USE CAUTION WHEN REMOVING!	As Needed

TROUBLESHOOTING

Problem	Possible Cause	Solution
Char Broiler not lighting	Main gas line is closed. Quick disconnect not inserted all the way. Pilot light is not lit. Cause unknown	Open Valve Check quick disconnect and make sure it is fully inserted into female coupling. Ignite pilot light. Call for service.
Flame is too high or too low	Adjustment knob is turned up or down	Adjust flame with control knob.
Pilot light not staying lit.	Flame is too low Pilot tube clogged.	Adjust pilot light flame height. Replace pilot tube. Call for service.
Strong smell of gas in cooking area.	Main gas line leak One or more of the pilots may be out and a burner knob turned on.	Turn off main gas valve. DO NOT LIGHT FLAME, ignite anything, or turn/switch on anything electrical. Call Fire department if needed and call for service. Check to see if burners and pilots are lit. If not, turn off all burner valves and main gas valve and wait for excess gas to dissipate. Reattempt to light pilots after allowing excess gas to clear.
Cooking surface is heating up slowly.	Carbon buildup on Char Broiler surface. Cause unknown	Clean Char Broiler surface. Call for service.
Gas type of unit needs to be converted.	Unit ships from the factory Natural gas. Conversion from Natural Gas to L.P. is possible for this unit.	Call for service. This is not considered a warranty issue. Do not attempt conversion on your own.

If problems persist and the assigned solution does not remedy the issue, please call for service.

PARTS

NOTICE

INSTALLATION OF OTHER THAN GENUINE MOTAK PARTS WILL VOID THE WARRANTY AND LIABILITY ON THIS EQUIPMENT.

The serial plate is located on the right side panel toward the rear. Replacement parts may be ordered either through an Authorized Parts Distributor or an Authorized Service Agency

When ordering parts, please supply the Model Number, Serial Number, Part Number, and Description.

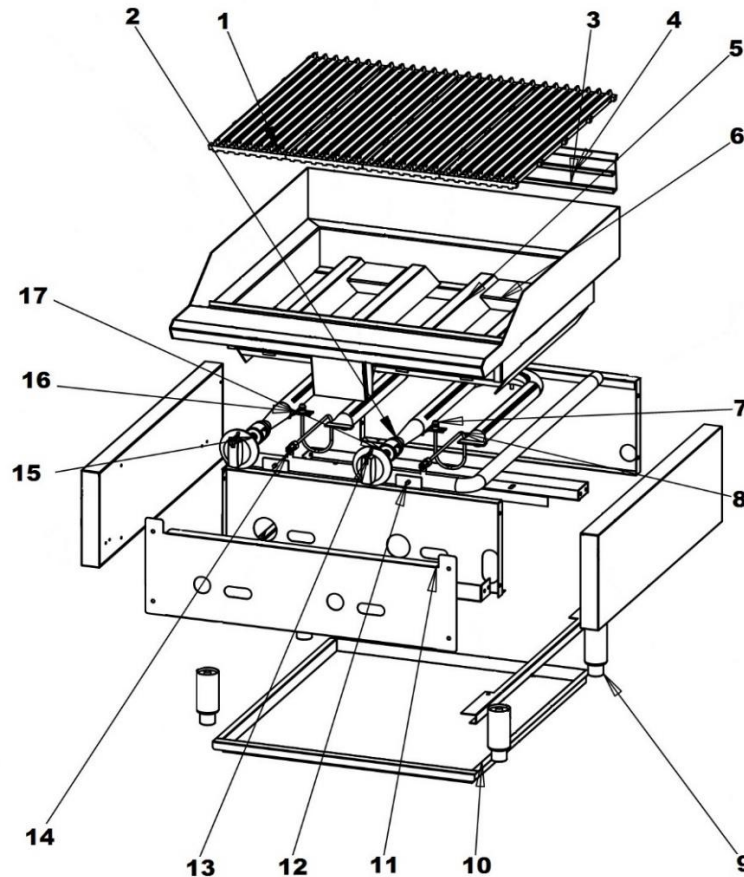

Ref	Part #	Description	Ref #	Part #	Description
1	GC10016	Cooking Grate	10	GC10022-24 GC10022-36 GC10022-48	Drip Pan 24" Drip Pan 36" Drip Pan 48"
2 *	GC10001 GC10019	U-Shaped Burner Burner Radiant (2 per Burner)	11	GC10040 GC10041 GC10042	CB Front Panel 24" CB Front Panel 36" CB Front Panel 48"
3 / 4	GC10018-24	Height Adjustment 24"	12	GC10024	Gas inlet Pipe
3 / 4	GC10018-36	Height Adjustment 36"	13	GC10010	Control Knob
3 / 4	GC10018-48	Height Adjustment 48"	14	GC10005	Pilot Adjustment Valve
6	GC10020	Burner Radiant Support	15	GC10004	Gas Valve
7	GC10003	Pilot	16	GC10002	Pilot Bracket
8	GC10021	Pilot Tubing	17	GC10009 GC10009-LP	Orifice Hood NAT #36 Orifice Hood LPG #48
9	GC10008	4" Adjustable Leg	*	GC10015	Pressure Regulator

*Not Shown

PAGE LEFT BLANK INTENTIONALLY

PAGE LEFT BLANK INTENTIONALLY

PAGE LEFT BLANK INTENTIONALLY



DISTRIBUTED BY KATOM RESTAURANT SUPPLY, INC.

**305 KATOM DRIVE KODAK TN 37764 USA
PHONE: 865-225-1545**

FOR WARRANTY SERVICE CALL 833-474-0367

A product with the MOTAK name incorporates the best in durability and low maintenance. We all recognize, however, that replacement parts and occasional professional service may be necessary to extend the useful life of this unit. When service is needed, contact an MOTAK Authorized Service Agency, or your dealer. To avoid confusion, always refer to the Model Number, Serial Number, and Type of gas that is found on the data tag of your appliance.

