



Architect/Engineering Specifications:

1.15 GPM spray valve (less hold down ring), polished chrome plated forged body with rubber bumper and 3/4-14 UN male inlet. Certified to ASME A112.18.1/CSA B125.1, NSF 61-Section 9 and NSF 372. 2019 DOE PRSV - Class II compliant.

Job Name \_\_\_\_\_

Model Specified \_\_\_\_\_ Quantity \_\_\_\_\_

Variations Specified \_\_\_\_\_

Date \_\_\_\_\_

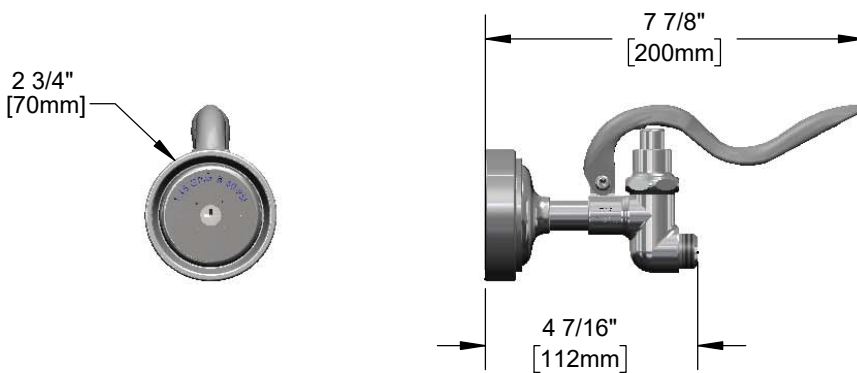

Features & Benefits:

- Designed for heavy-duty use in industrial kitchens
- 1.15 GPM spray valve (less hold down ring)
- Shuts off when handle is released
- 3/4-14 UN male inlet
- Material: Polished chrome plated brass body and rubber bumper

Product Compliance:

- ASME A112.18.1 / CSA B125.1
- NSF 61 - Section 9
- NSF 372 (Low Lead Content)
- 2019 DOE PRSV - Class II

Warranty: One Year (Limited)

Performance Data:

- Pressure: 20 - 125 psi
- Temperature: 40 °F - 140 °F
- Flow Rate: 1.15 GPM @ 60 psi
- Spray Force: 7.5 Ozf (212 Gramf) @ 60 psi

