

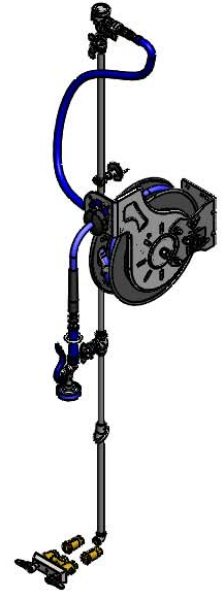

Architect/Engineering Specifications:

3" concealed mixing faucet with brass body, chrome plated escutcheon, compression cartridges with spring checks, lever handles, 3/8" NPT female inlets and outlet, 1/2" NPT in-line check valves with 1/2" NPT female inlets, 26" riser, control valve, 40" riser, wall bracket, angled slip flange, continuous pressure vacuum breaker, 36" flexible water hose connector with stainless steel quick disconnect, open coated hose reel with 3/8" x 35' heavy-duty non-marking hose, ratcheting system, high flow spray valve with swivel, multi-fit bracket and adjustable hose bumper. Certified to ASSE 1056.

Job Name _____
 Model Specified _____ Quantity _____
 Variations Specified _____
 Date _____

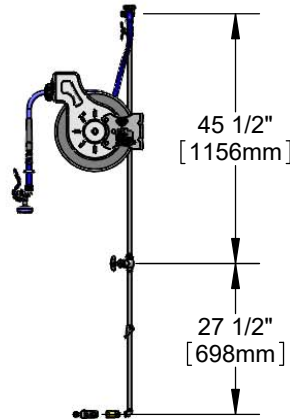
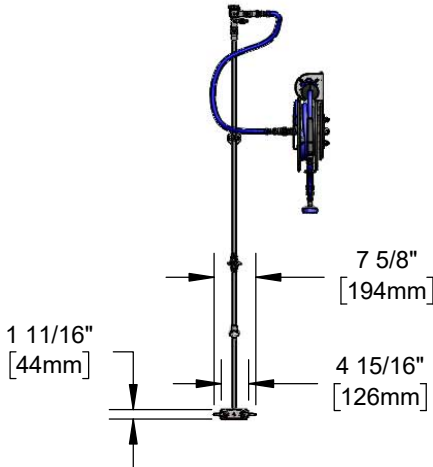

Features & Benefits:

- All-in-one system with exposed piping and accessories
- 3" concealed mixing faucet w/ brass body
- Quarter-turn Eterna compression cartridges w/ spring checks to prevent cross flow of water
- Lever handles w/ color coded indexes
- Mixing faucet, 3/8" NPT female inlets & outlet
- 1/2" NPT in-line check valves (2) w/ 1/2" NPT female inlets
- 26" and 40" risers w/ control valve between risers
- 2 3/8" wall bracket
- Continuous pressure vacuum breaker
- 36" flexible water hose connector with stainless steel quick disconnect
- Open coated hose reel
- High flow spray valve w/ heat resistant blue handle, hold down ring & swivel
- 3/8" x 35' heavy-duty non-marking hose rated to 300 PSI
- Ratcheting system holds the length of hose until a slight tug to retract automatically
- Adjustable hose bumper
- Multi-fit bracket for wall, ceiling or under counter mounting
- Material: Brass body faucet, chrome plated brass spray valve & riser, escutcheon, chrome plated metal handles, control valve, vacuum breaker and epoxy coated reel.

Product Compliance:

- NSF 61 Exempt (Non-Potable)
- 2019 DOE PRSV Non-Compliant
- ASSE 1056 (VB)



Warranty: One Year (Limited)

- Hose Reel: Two Year (Limited)
- Hose: One Year (Limited)

Performance Data:

- Pressure: 20 - 125 psi
- Temperature: 40 °F - 140 °F
- Flow Rate: 2.84 GPM @ 60 psi

Optional Hose Reel Spray Valves

- B-0107 Spray Valve
- B-0108 Ergonomic Medium Flow Spray Valve
- B-0108-H Ergonomic High Flow Spray Valve
- EB-0107 High Flow Spray Valve (Standard)
- EB-2322 Extended Spray Wand
- MV-2516-24 Stainless Steel Rear Trigger Water Gun
- MV-2522-24 Stainless Steel Front Trigger Water Gun
- MV-3516-24 Aluminum Rear Trigger Water Gun

