



# SCR1536BG



33.88" x 14.75" x 22.75" (H x W x D)

15" wide built-in undercounter glass door beverage cooler for home or commercial use, with digital controls, lock, LED light, and black cabinet

## Highlights:

Just under 15" wide for an easy fit, with a flush back design to save space

Flexible design allows built-in or freestanding use under counters

Digital thermostat offers precise and convenient temperature control

Factory-installed lock provides security you can count on

## Product Features:

Right angle plug	Design allows you to plug the unit in flush against the wall socket with no need to add extra depth
Commercially approved	ETL-S listed to NSF-7 Standards for use in commercial establishments
Built-in capable	Make the best use of space by installing your appliance under the counter
Fully finished black cabinet	Allows the unit to be used freestanding
Glass door with stainless steel trim	Provides a full display of stored contents with a heat-safe double tempered design
Factory installed lock	Keyed security on the door
Digital thermostat	Electronic controls for precise temperature management.
Digital display	Temperature readout can be shown in Celsius or Fahrenheit
LED lighting	Gentle illumination with an on/off switch



SUMMIT APPLIANCE DIVISION FELIX STORCH, INC.

770 Garrison Avenue, Bronx, NY 10474 USA TEL 718-893-3900 FAX 844-478-8799 info@summitappliance.com  www.summitappliance.com



## SCR1536BG Specifications:

Overview	
Height	33.88"
Width	14.75"
Depth	22.75"
Depth with Handle	24.63"
Depth with door at 90°	36.25"
Capacity	2.45 cu.ft.
Defrost Type	Automatic
Door	Glass
Cabinet	Black
US Electrical Safety	ETL
Canadian Electrical Safety	ETL-C
Sanitation	ETL-S
Energy Usage/Year	245.0kWh/year
Amps	1.0
Voltage/Frequency	115 V AC/60 Hz
Weight	77.0 lbs.
Shipping Weight	95.0 lbs.
Parts & Labor Warranty	1 Year
Compressor Warranty	5 Years
Refrigerator Features	
Door Swing	RHD
Reversible	Yes
Shelf Type	Chrome
Shelf Qty	3
Thermostat Type	Digital
Refrigerant Type	R134a
Refrigerant Amount	1.4oz.
High Side PSI	270.0
Low Side PSI	103.0
Level Legs Qty	4
Interior Light	Yes
Dimensions	
Interior Height	23.5"
Interior Width	10.25"
Interior Depth	16.5"
Compressor Step Height	3.75"
Compressor Step Width	10.25"

Compressor Step Depth

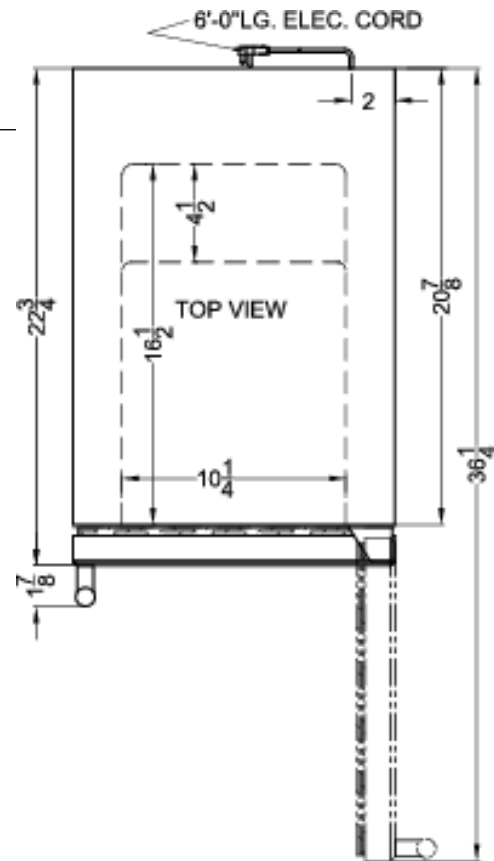

SUMMIT APPLIANCE DIVISION FELIX STORCH, INC.

770 Garrison Avenue, Bronx, NY 10474 USA TEL 718-893-3900 FAX 844-478-8799 info@summitappliance.com www.summitappliance.com

