



**John  
BOOS**  
Since 1887

ITEM #: \_\_\_\_\_ QTY: \_\_\_\_\_  
 MODEL #: \_\_\_\_\_  
 PROJECT NAME: \_\_\_\_\_

041221

3601 S. Banker St. Effingham, IL 62401 • Ph: (888) 431-2667 • Fax: (800) 433-2667

## **"UBIB-21-CP10" UNDERBAR ICE BIN** **21" WIDTH, 10 CIRCUIT COLD PLATE**



### **STANDARD FEATURES:**

- ALL 18 GAUGE STAINLESS STEEL CONSTRUCTION
- TYPE 300 STAINLESS STEEL WITH #4 POLISH, SATIN FINISH
- FOAM INSULATED ICE BIN
- 10 CIRCUIT COLD PLATE
- STANDARD THREADED INSERTS ON SIDES FOR ATTACHING ADJACENT UNITS TOGETHER
- STANDARD FRONT INSERTS FOR SPEED RAIL ATTACHMENT
- ACCESS PLATES ON TOP OF BACKSPLASH FOR SODA GUN LINES
- STAINLESS STEEL FRONT TO BACK BRACING



### **SPECIFICATIONS:**

- MATERIALS
  - TOP: 18 GAUGE TYPE 300 STAINLESS STEEL
  - FRONT APRON: 18 GAUGE TYPE 300 STAINLESS STEEL
  - BACKSPLASH: 18 GAUGE TYPE 300 STAINLESS STEEL
  - SIDES: 18 GAUGE TYPE 300 STAINLESS STEEL
- LEGS AND BRACING
  - BOLT ON 1-5/8" STAINLESS STEEL LEGS FOR FAST INSTALLATION
  - 1-1/4" FRONT TO BACK BRACING
  - 1" ADJUSTABLE STAINLESS STEEL BULLET FEET
- MOUNTING OPTIONS
  - Z-CLIP TO MOUNT TO WALL
  - BOLT TO ADJACENT UNDERBAR PIECE
  - LEGS NOT TO BE REMOVED ON ICE BINS
- PLUMBING
  - 1-7/8" DRAIN PLUG
  - 1" MPT 3-1/4" LONG DRAIN CONNECTION
- NSF CERTIFIED

ACCESSORIES	DESCRIPTION
UBSS-21-L	LEFT HAND SIDE SPLASH
UBSS-21-R	RIGHT HAND SIDE SPLASH
EUBSR-24	24" SINGLE SPEED RAIL
EUBSR-30	30" SINGLE SPEED RAIL
EUBSR-36	36" SINGLE SPEED RAIL
EUBSR-2-24	24" DOUBLE SPEED RAIL
EUBSR-2-30	30" DOUBLE SPEED RAIL
EUBSR-2-36	36" DOUBLE SPEED RAIL
UBIBL-2130-BWH	BOTTLE WELL HOLDER WITH LID FOR 30"X21" ICE BIN

### **ICE BIN - 21" WIDTH, 10 CIRCUIT COLD PLATE**

MODEL #	SIZE (LXWXH)	LENGTH (L)	WT. (LBS)
UBIB-2130-CP10	30"X21"X32-1/2"	30"	205
UBIB-2136-CP10	36"X21"X32-1/2"	36"	215

# DETAILED SPECIFICATIONS

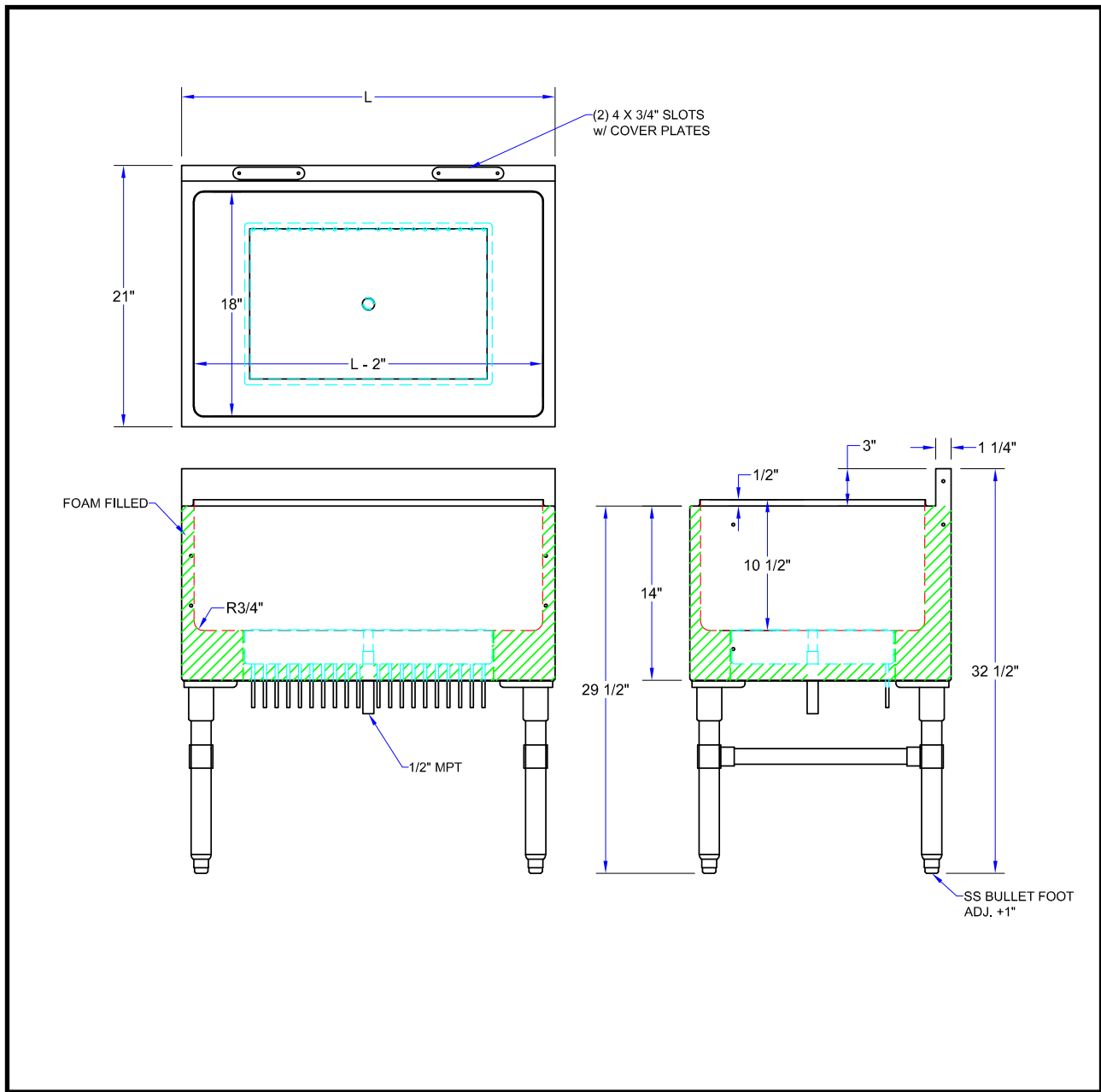

## ICE BIN - 21" WIDTH, 10 CIRCUIT COLD PLATE

MODEL #	SIZE (LXWXH)	LENGTH (L)	WT. (LBS)
UBIB-2130-CP10	30"X21"X32-1/2"	30"	205
UBIB-2136-CP10	36"X21"X32-1/2"	36"	215

SOME UNITS SHIP UNASSEMBLED FOR REDUCED SHIPPING COST. ALL DIMENSIONS ARE TYPICAL. TOLERANCE +/- .500"  
 John Boos & Co. is constantly engaged in a program of improving products and therefore reserves the right to change specifications without prior notice.



3601 S. Banker St. • Effingham, IL 62401 • quotes@johnboos.com

041221

37



[www.johnboos.com](http://www.johnboos.com)