

APPLICATION:

PRODUCT NAME:
SWIVEL SPOUTS 2.2 GPM

JOB NAME:

MODEL:

QUANTITY:

ITEM NO.:

- 3960 6" SWIVEL SPOUT
- 3961 8" SWIVEL SPOUT
- 3962 10" SWIVEL SPOUT
- 3963 12" SWIVEL SPOUT
- 3964 14" SWIVEL SPOUT
- 3967 16" SWIVEL SPOUT

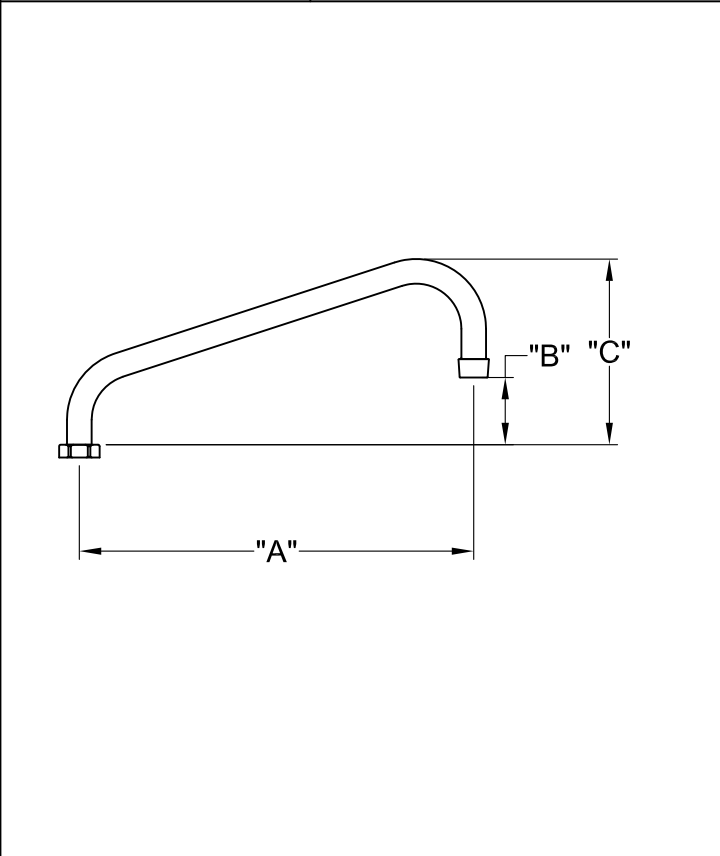

OPTIONS OR MODIFICATIONS:
 OTHER _____

FEATURES

- * 2.2 GPM AERATOR

RECOMMENDED SETTINGS

- * 110°F AT 80 PSI

SYSTEM LIMITS

- * TEMP: 40°F MIN. TO 160°F MAX.
- * PRESSURE: 200 PSI MAX. STATIC

SHIPPING WEIGHT

- * 0.75 LBS

PRODUCT COMPLIANCE:

- * ASME A112.18.1 / CSA B125.1
- * NSF 61 - Section 9
- * NSF 372 (Low Lead Content)

MODEL	DIM "A"	DIM "B"	DIM "C"
3960	6" [152mm]	3/8" [10mm]	4" [102mm]
3961	8" [204mm]	1-1/4" [33mm]	5" [127mm]
3962	10" [254mm]	1-1/4" [33mm]	5" [127mm]
3963	12" [305mm]	2" [51mm]	5-3/4" [145mm]
3964	14" [356mm]	2-5/8" [67mm]	6-1/4" [160mm]
3967	16" [406mm]	3-1/4" [83mm]	7" [178mm]



FISHER MANUFACTURING COMPANY
TOLL FREE: 800-421-6162 - FAX: 800-832-8238
information@fisher-mfg.com - www.fisher-mfg.com