

PRODUCT SPECIFICATIONS

Elkay Stainless Steel 22" x 19" x 5-1/2", Wall Hung Lavatory Sink Kit. Sink is manufactured from 304 Stainless Steel with a Buffed Satin finish, Rear Center drain placement, and Bottom only pads.

Material:	304 Stainless Steel
Finish:	Buffed Satin
Sound Deadening:	Bottom only pads
Number of Bowls:	1
Sink Dimensions:	22" x 19" x 19-1/8"
Bowl 1 Dimensions:	16" x 11-1/2" x 5-1/2"
Drain Size:	1-1/2" (38mm)
Drain Location:	Rear Center



Included with Product: ELV2219 sink, one LKB721C sensor faucet with AC plug-in / 4 AA batteries

▼ **Ships in multiple boxes.**

AMERICAN PRIDE. A LIFETIME TRADITION.

Like your family, the Elkay family has values and traditions that endure. For almost a century, Elkay has been a family-owned and operated company, providing thousands of jobs that support our families and communities.



Product Compliance: ADA & ICC A117.1

Buy American Act
NSF 2

Faucet: ASME A112.18.1/CSA B125.1
NSF 61
NSF 372 (lead free)



Complies with ADA & ICC A117.1 accessibility requirements when installed according to the requirements outlined in these standards.

[Clean and Care Manual \(PDF\)](#)

[Installation Instructions \(PDF\)](#)

[Warranty \(PDF\)](#)

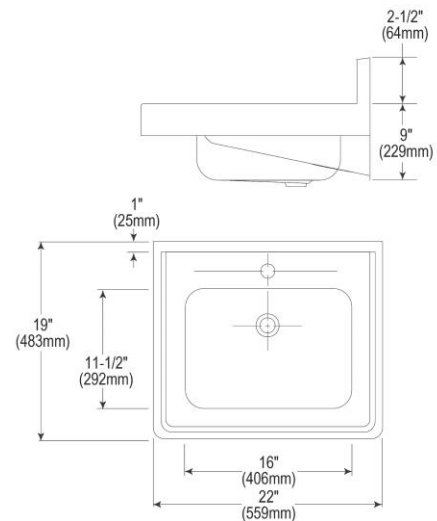

PART: _____ QTY: _____

PROJECT: _____

CONTACT: _____

DATE: _____

NOTES: _____

APPROVAL: _____

In keeping with our policy of continuing product improvement, Elkay reserves the right to change product specifications without notice. Please visit elkay.com for the most current version of Elkay product specification sheets. This specification describes an Elkay product with design, quality, and functional benefits to the user. When making a comparison of other producers' offerings, be certain these features are not overlooked.

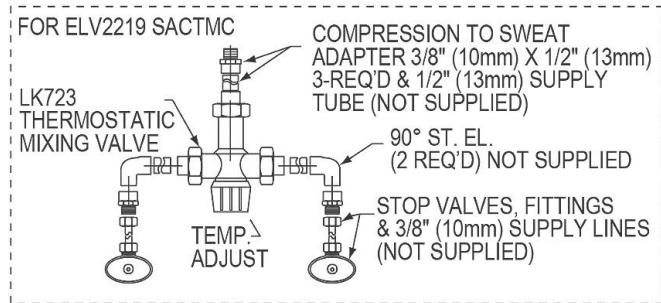
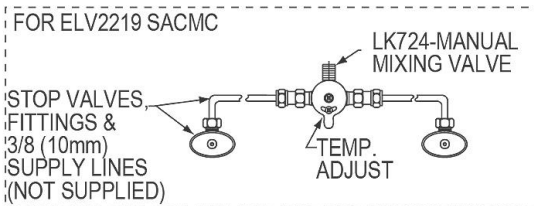
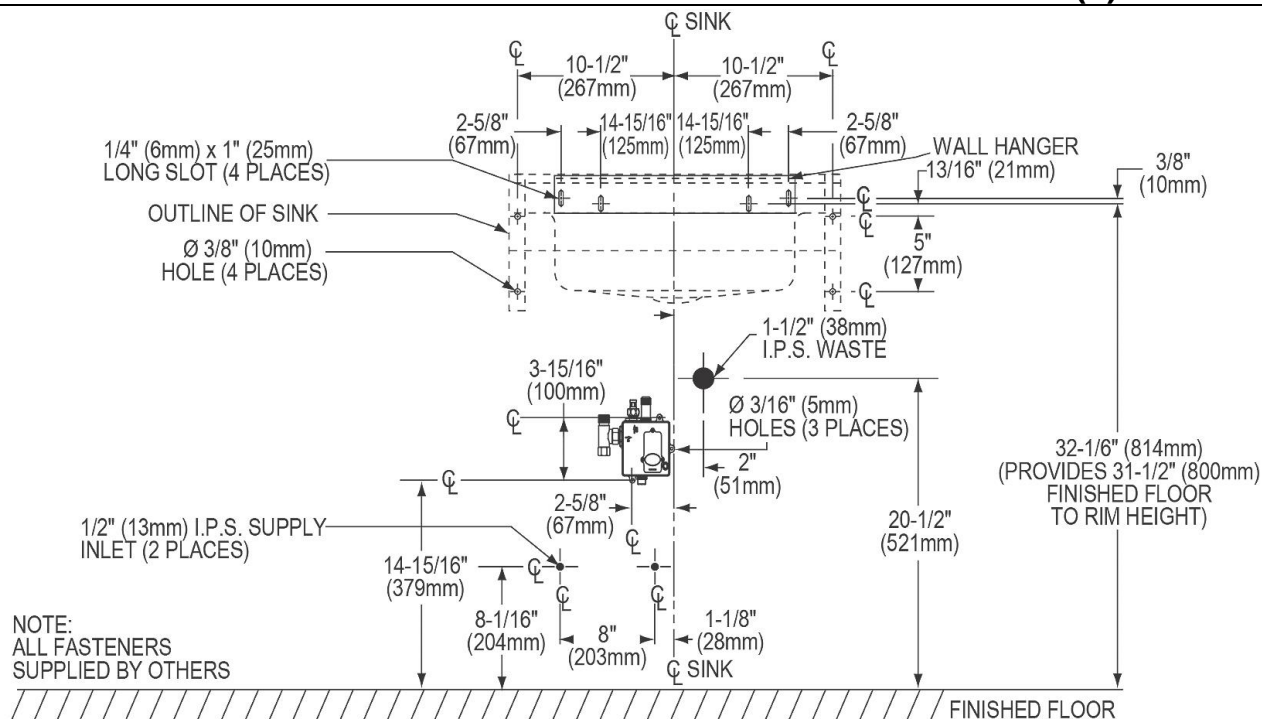

NOTE:
USE TEFLON TAPE FOR ALL WATER CONNECTIONS.
DO NOT USE PIPE DOPE.

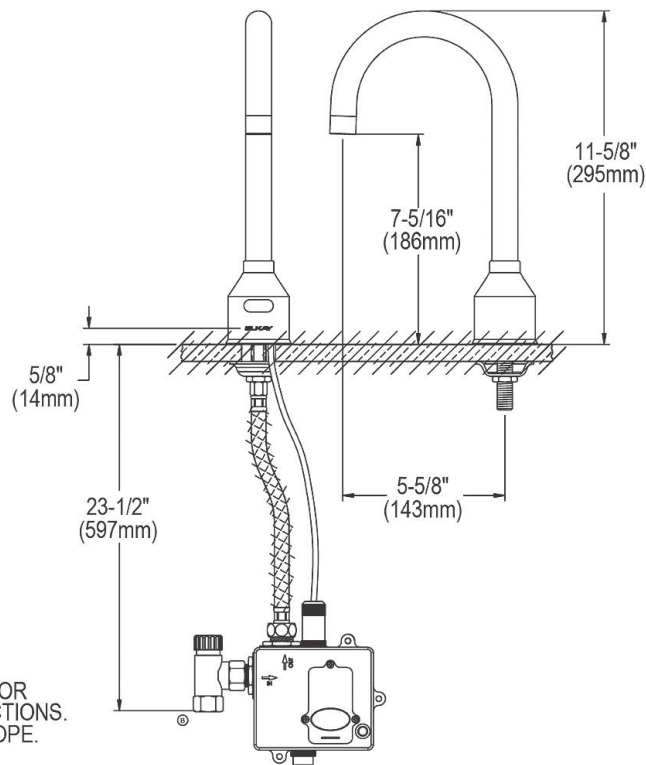

In keeping with our policy of continuing product improvement, Elkay reserves the right to change product specifications without notice. Please visit elkay.com for the most current version of Elkay product specification sheets. This specification describes an Elkay product with design, quality, and functional benefits to the user. When making a comparison of other producers' offerings, be certain these features are not overlooked.