



Warewashing Systems

INSTALLATION, OPERATION, AND SERVICE MANUAL



AJX S E R I E S

AJX SERIES CONVEYOR DISHMACHINES

AJX Series Manual • 07610-003-60-98-L

**MANUFACTURER'S LIMITED WARRANTY
(APPLICABLE ONLY IN THE UNITED STATES AND CANADA)**

WARRANTY REGISTRATION:

To register your Jackson Dishmachine's warranty go to www.jacksonwws-warranty.com or call 1-888-800-5672. Failure to register the Dishmachine will void the warranty.

ONE YEAR LIMITED PARTS AND LABOR WARRANTY

For a period of one (1) year from date of original installation of a new Jackson Dishmachine (but in no event to exceed eighteen (18) months from date of shipment from Jackson's factory), Jackson WWS, Inc. (Jackson) will repair or replace, at its discretion, any original part that proves defective in materials or workmanship at the time the Dishmachine was purchased; provided that (i) the Dishmachine has not been altered, (ii) the Dishmachine has been properly installed, maintained, and operated under normal use conditions and in accordance with the applicable installation, operation and service manual available on the Jackson website, and (iii) a warranty claim is reported to a Jackson Authorized Service Agency within the warranty period. This warranty includes replacement with Jackson specified genuine replacement parts, purchased directly from a Jackson Authorized Parts Distributor or Service Agency. Use of generic replacement parts may create a hazard and shall void this warranty.

THIS WARRANTY DOES NOT APPLY OUTSIDE THE UNITED STATES AND CANADA.

Jackson will pay the labor to repair or replace a defective original part as a part of the warranty, provided that a Jackson Authorized Service Agency performs the labor. Any repair or replacement work by anyone other than a Jackson Authorized Service Agency is the sole responsibility of the purchaser. Labor coverage is limited to regular hourly rates; Jackson will not pay overtime premiums or emergency service charges.

Accessory components (such as table limit switches, pressure regulators, and drain water tempering kits) that are not installed by Jackson at the factory and are shipped with the Dishmachine carry only a (1) one year parts warranty. Labor to repair or replace these components is not included in the warranty or covered by Jackson. Booster heaters not manufactured by Jackson are not covered by this warranty, but are warranted by their respective manufacturers.

This warranty is void if any defect or failure is a direct result from shipping, handling, fire, water, accident, alteration, modification, misuse, abuse, flood, acts of God, burglary, casualty, attempted repair by unauthorized persons, use of replacement parts not authorized by Jackson, improper installation, installation not in accordance with local electrical and plumbing codes, if the serial number has been removed or altered, if the Dishmachine is used for any purpose other than originally intended, or if the equipment is installed for residential use.

Jackson does not authorize any other entity or person, including, without limitation, any entity or person who deals in Jackson's Dishmachines, to change this warranty or create any other obligation in connection with Jackson's Dishmachines.

TRAVEL LIMITATIONS:

Jackson limits warranty travel time to the customer site within 50 miles of the Jackson authorized service agents office and during regular business hours. Jackson will not pay for travel time and mileage that exceeds these limits, or any fees such as those for air or boat travel without prior authorization.

REPLACEMENT PARTS WARRANTY:

For a period of (90) ninety days from the date of installation by a Jackson Authorized Service Agency (but in no event to exceed (180) one-hundred-eighty days from the date of purchase from a Jackson Authorized Parts Distributor or Service Agency), Jackson will repair or replace, at its discretion, any Jackson genuine replacement parts that prove defective in materials or workmanship at the time the replacement parts were installed. This warranty does not include paying the labor to repair or replace the replacement part. This warranty is subject to all conditions, exclusions and limitations applicable to the Dishmachine.

**MANUFACTURER'S LIMITED WARRANTY (CONT.)
(APPLICABLE ONLY IN THE UNITED STATES AND CANADA)**

PRODUCT CHANGES:

Jackson reserves the right to make changes in design and specification of any component of the Dishmachine as engineering or necessity requires.

DISCLAIMER OF WARRANTIES:

THERE ARE NO WARRANTIES, EXPRESSED OR IMPLIED, INCLUDING, WITHOUT LIMITATION, ANY IMPLIED WARRANTY OF FITNESS FOR A PARTICULAR PURPOSE OR MERCHANTABILITY, THAT ARE NOT SET FORTH HEREIN, OR THAT EXTEND BEYOND THE DURATION HEREOF.

LIMITATION OF REMEDIES AND LIABILITIES:

YOUR SOLE AND EXCLUSIVE REMEDY UNDER THIS LIMITED WARRANTY SHALL BE PRODUCT REPAIR OR REPLACEMENT AS PROVIDED HEREIN.

UNDER NO CIRCUMSTANCES WILL JACKSON BE LIABLE FOR ANY INCIDENTAL OR CONSEQUENTIAL DAMAGES, OR FOR DAMAGES IN THE NATURE OF PENALTIES. JACKSON'S LIABILITY ON ANY CLAIM OF ANY KIND WITH RESPECT TO THE GOODS OR SERVICES COVERED HEREUNDER SHALL IN NO CASE EXCEED THE PRICE OF THE GOODS OR SERVICES OR PART THEREOF WHICH GIVES RISE TO THE CLAIM.

ITEMS NOT COVERED:

THIS WARRANTY DOES NOT COVER (1) ADJUSTMENTS INCLUDING, BUT NOT LIMITED TO, TIMER CAMS, THERMOSTATS, DOORS, TANK HEATER ADJUSTMENTS OR CLUTCHES; (2) AIR FREIGHT OR OVERNIGHT FREIGHT; (3) ANY AMOUNT EXCEEDING ORIGINAL PURCHASE PRICE; (4) CLEANING OF DRAIN VALVES, GAS LINES, RINSE/WASH NOZZLES, STRAINERS, SCREENS, OR SPRAY PIPES; (5) CLEANING OR DELIMING OF THE DISHMACHINE OR ANY COMPONENT INCLUDING, BUT NOT LIMITED TO, WASH ARMS, RINSE ARMS AND STRAINERS; (6) CONDITIONS CAUSED BY THE USE OF INCORRECT (NON-COMMERCIAL) GRADE DETERGENTS; (7) CORROSION FROM CHEMICALS DISPENSED IN EXCESS OF RECOMMENDED CONCENTRATIONS; (8) COSMETIC DAMAGE, INCLUDING BUT NOT LIMITED TO, SCRATCHES, DENTS, CHIPS, AND OTHER DAMAGE TO THE DISHMACHINE FINISHES, UNLESS SUCH DAMAGE RESULTS FROM DEFECTS IN MATERIALS AND WORKMANSHIP AND IS REPORTED TO JACKSON WITHIN (30) THIRTY DAYS FROM THE DATE OF INSTALLATION; (9) DAMAGE CAUSED BY LABOR DISPUTE; (10) DAMAGES RESULTING FROM IMPROPER CONNECTION TO UTILITY SERVICE; (11) DAMAGES RESULTING FROM WATER CONDITIONS, INADEQUATE OR EXCESSIVE WATER PRESSURE, ACCIDENTS, ALTERATIONS, IMPROPER USE, ABUSE, HANDLING, OVERLOADS, TAMPERING, IMPROPER INSTALLATION OR FAILURE TO FOLLOW MAINTENANCE AND OPERATING PROCEDURES; (12) DISCOLORATION, RUST OR OXIDATION OF SURFACES RESULTING FROM CAUSTIC OR CORROSIVE ENVIRONMENTS, INCLUDING, BUT NOT LIMITED TO, HIGH SALT CONCENTRATIONS, HIGH MOISTURE OR HUMIDITY, OR EXPOSURE TO CHEMICALS; (13) ELECTRIC BOOSTERS, FEED LINES, FLEX HOSE, FUSES, GARBAGE DISPOSALS, OR GAS PILOTS; (14) EXCESSIVE LIME, MINERAL, OR ALKALINE BUILDUP; (15) EXPENSES DUE TO DISCONNECTION, DELIVERY, RETURN AND REINSTALLATION; (16) FAILURE OF ELECTRICAL COMPONENTS DUE TO CONNECTION OF CHEMICAL DISPENSING EQUIPMENT INSTALLED BY OTHERS; (17) FAILURE OF FACILITY WATER HEATER TO MAKE TEMPERATURE; (18) FAILURE TO MAINTAIN WATER HARDNESS LOWER THAN 3.0 GRAINS, PH BETWEEN 7.0 AND 8.5 AND TOTAL DISSOLVED SOLIDS BELOW 250 PPM; (19) FAILURE TO COMPLY WITH LOCAL ELECTRICAL BUILDING CODES; (20) LEAKS OR DAMAGE RESULTING FROM SUCH LEAKS CAUSED BY THE INSTALLER, INCLUDING THOSE AT MACHINE TABLE CONNECTIONS, OR BY CONNECTION OF CHEMICAL DISPENSING EQUIPMENT INSTALLED BY OTHERS; (21) OPENING OR CLOSING OF UTILITY SUPPLY VALVES OR SWITCHING OF ELECTRICAL SUPPLY CURRENT; (22) PERFORMANCE OF REGULAR MAINTENANCE AND CLEANING AS OUTLINED IN THE OPERATOR'S GUIDE; (23) REMOVAL OR REINSTALLATION OF INACCESSIBLE DISHMACHINES OR BUILT-IN FIXTURES THAT INTERFERE WITH SERVICING, REMOVAL OR REPLACEMENT OF THE DISHMACHINE; (24) REPLACEMENT WEAR ITEMS INCLUDING, BUT NOT LIMITED TO, CURTAINS, DRAIN BALLS, DOOR GUIDES, GASKETS, O-RINGS, SEALS, SQUEEZE TUBES, AND BEARINGS; (25) RESIDENTIAL USE; (26) USE WITH UTILITY SERVICE OTHER THAN THAT DESIGNATED ON THE RATING PLATE.

REVISION HISTORY

Revision Letter	Revision Date	Made by	Applicable ECNs	Details
A	1-19-09	JC	Process	Initial release of manual.
B	1-30-09	JC	Process	Added 15 kW heater option and adjusted amperage ratings.
C	10-6-09	RC	N/A	Added curtain installation diagram.
D	10-9-09	ARL	8044	Changed the part from a weldment (05700-021-67-50) to a casting (09515-003-58-12).
E	12-1-09	ARL	091125-1404-CW	Changed a dimension on pg. 30, the dimension between the mounting holes was indicated as 2.00", but should have been 2.88".
F	10-29-10	RLC	101029-1336-CW	Updated Print for mounting Table Limit Switch.
G	5-9-12	RLC	QOF 386	Added chart for cut lengths on 66,76,80, and 90 L-R drain plumbing.
H	3-19-13	RLC	QOF NDB-219	Updated manufacturer information.
J	10-13-14	KAP	N/A	Updated manufacturer logo and information.
K	8-17-17	JH	8509	Updated manual to new format. Audited manual and made corrections throughout. Changed AJX-44/54 Drain Plumbing Assembly.
L	10-25-19	JH	QOF 18-022	Complete revision of manual. Added electrical requirements for available 380 V machines. Changed steam pressure to 10–30 PSI. Updated Item #7 on Motor page. Added 15 kW heater gasket on Heater page. Updated Item #11 on Curtains/Conveyor Switch page. Changed curtain rod P/N on pg. 79.

Jackson[®]

Warewashing Systems

**AJX-44CE, AJX-54CE, AJX-66CE,
AJX-76CE, AJX-80CE, AJX-90CE**

**Electrically-heated rack conveyor machines,
available in chemical-sanitizing and
hot-water-sanitizing models.**

**AJX-44CS, AJX-54CS, AJX-66CS,
AJX-76CS, AJX-80CS, AJX-90CS**

**Steam-heated, hot-water-sanitizing
rack conveyor machines.**

The manufacturer provides technical support for all of the machines detailed in this manual. We strongly recommend that you refer to this manual before making a call to our technical support staff. Please have this manual open when you call so that our staff can refer you, if necessary, to the proper page. Technical support is not available on holidays.

Contact technical support toll free at 1-888-800-5672.

Technical support is available for service personnel only.

TABLE OF CONTENTS

GUIDES

Symbols	1
Abbreviations & Acronyms	1

SPECIFICATIONS

Machine Dimensions	2
Side-loader Dimensions	14
Side-loader & Table Install	16
Operating Parameters	17
Electrical Requirements	18

INSTALLATION

Installation Instructions	21
<i>Inspection</i>	21
<i>Unpacking</i>	21
<i>Leveling</i>	21
<i>Facility Hot Water Heater</i>	21
<i>Plumbing</i>	22
<i>Drain Line</i>	22
<i>Steam Line Connections</i>	23
<i>Electrical Power Connections</i>	23
<i>Motor Rotation</i>	24
<i>Ventilation</i>	24
<i>Thermostats</i>	24
<i>Table Limit Switch Option</i>	24
<i>Chemical Feeder Equipment</i>	25
<i>Connection Points</i>	26
<i>Exhaust Fan Timer</i>	26
<i>Curtains</i>	27

OPERATION

Operating Instructions	28
<i>Preparation</i>	28
<i>Power Up</i>	28
<i>First Rack</i>	29
<i>Ware Preparation</i>	29
<i>Washing a Rack of Ware</i>	29
<i>Operational Inspection</i>	29
<i>Shutdown</i>	30
<i>Cleaning</i>	30
<i>Deliming</i>	32

TABLE OF CONTENTS

MAINTENANCE

Preventative Maintenance	33
Torque Settings	33
Drive Gear Reducer Lubrication	34

TROUBLESHOOTING

Common Problems	36
-----------------------	----

PARTS

AJX-44/54 Control Box	38
AJX-66/76/80/90 Control Box	40
Motor Overloads	42
Heater Box	44
Plumbing Options	48
Pre-wash Inlet Plumbing	49
Solenoid Valve & Vacuum Breaker	50
Rinse Inlet Plumbing	51
Steam Coil	53
Steam Plumbing, L-R	54
Steam Plumbing, R-L	55
AJX-44/54 Drain Plumbing	56
AJX-66/76/80/90 Drain Plumbing, L-R	57
AJX-66/76/80/90 Drain Plumbing, R-L	58
Drain Water Tempering System	59
Motor	60
Pre-wash & Wash Pumps	62
Lower Wash Arm	63
Pre-wash Arm & Upper Wash Arm	64
Final Rinse	65
Doors	66
Drive Assembly	67
Pawl Bar Roller Bracket	69
AJX-44/66 Pawl Bars	70
AJX-80 Pawl Bar	71
AJX-44 Rack Rails	72
AJX-66 Rack Rails	73
AJX-80 Rack Rails	74

PARTS

Strainers	75
Rinse Fill Option	76
Float Switch/Scrap Basket.....	77
Curtain/Conveyor Switch	78
Side-loader Parts.....	79
Miscellaneous Parts	81

SCHEMATICS

AJX-44/54CE 208-230 V/50-60 Hz/1-Phase	83
AJX-44/54CE 460 V/50-60 Hz/3-Phase.....	84
AJX-44/54CS 208-230 V/50-60 Hz/1-Phase	85
AJX-44/54CS 460 V/50-60 Hz/3-Phase.....	86
AJX-66/76/80/90CE 208-230 V/50-60 Hz/1-Phase	87
AJX-66/76/80/90CE 460 V/50-60 Hz/3-Phase.....	88
AJX-66/76/80/90CS 208-230 V/50-60 Hz/1-Phase	89
AJX-66/76/80/90CS 460 V/50-60 Hz/3-Phase.....	90
Side-loader	91
Exhaust Fan.....	92

SYMBOLS



- Risk of injury to personnel



- Risk of damage to equipment



- Risk of electrical shock



- Caustic chemicals



- Reference data plate



- Lockout electrical power

NOTICE - Important note



- Instructions Hyperlink

ABBREVIATIONS & ACRONYMS

ANSI - American National Standards Institute

CFM - Cubic Feet per Minute

FPM - Feet per Minute

GHT - Garden Hose Thread

GPM - Gallons per Minute

GPG - Grains per Gallon

HP - Horse Power

Hz - Hertz

ID - Inside Diameter

in/lbs - Inch Pounds

kW - Kilowatts

NFPA - National Fire Protection Association

NPT - National Pipe Thread

PSI - Pounds per Square Inch

V - Volts

AJX-44 LEFT-TO-RIGHT

LEGEND

- A - Main Water Inlet
(3/4" NPT, 180 °F MIN)
- B - Electrical Connection
- C - Drain Connection (1 1/2" NPT)
- D - Vent Collar - Optional
- E - Vent Cowl - Standard
- F - Machine Steam Inlet (3/4" NPT)
- G - Condensate Return (3/4" NPT)
- H - Steam Booster Electrical Connection (7/8" Hole)
- J - Booster Steam Inlet (1" NPT)
- K - Condensate Connection (3/4" NPT)
- L - Water Inlet for Booster (from Facility)
(3/4" NPT, 110 °F)
- M - Water Outlet to Machine
(3/4" NPT, 180 °F)

All dimensions from the floor can be increased 1" using the machine's adjustable feet.

Items in red are not supplied with the machine.

Items in blue are for the Steam option.

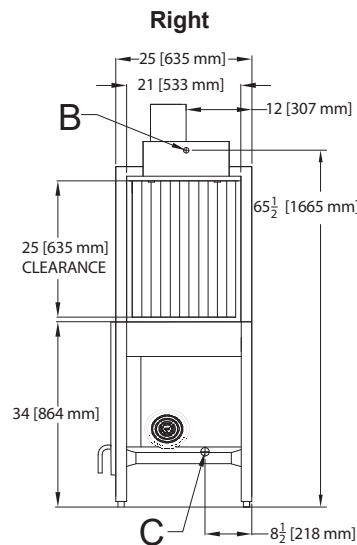
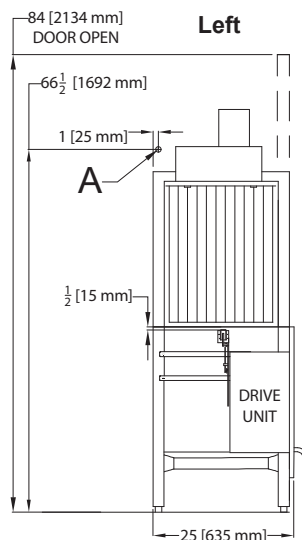
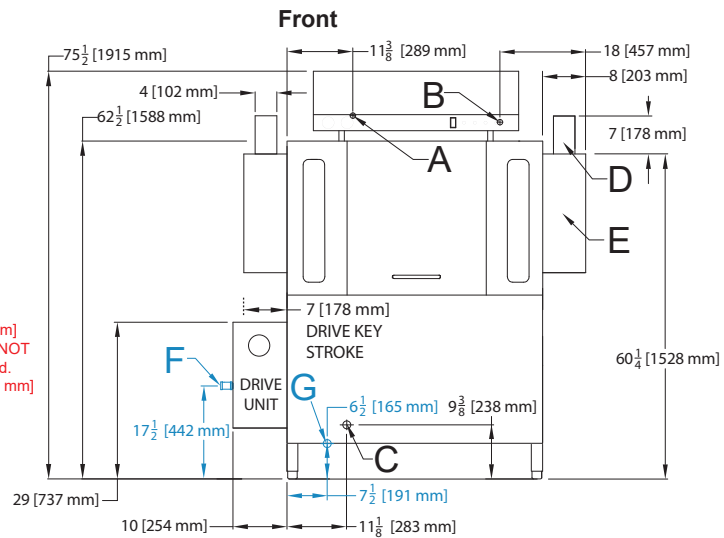
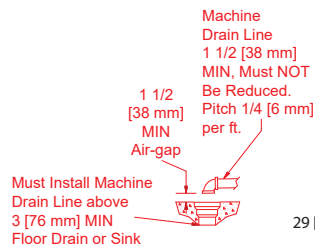
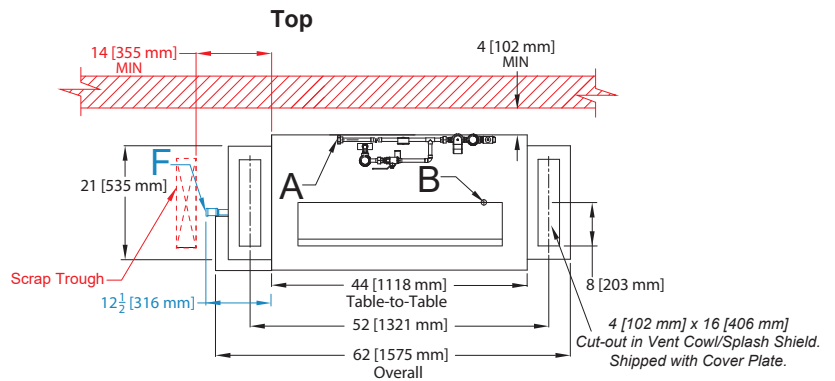

Steam Booster

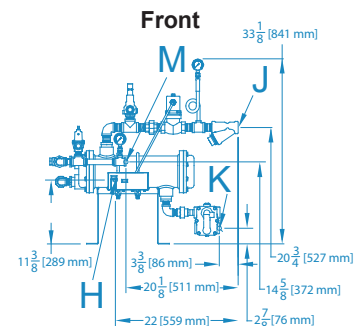
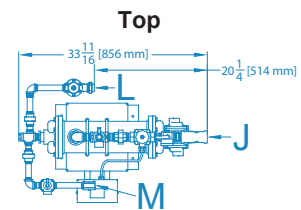

AJX-44 RIGHT-TO-LEFT

LEGEND

- A - Main Water Inlet (3/4" NPT, 180 °F MIN)
- B - Electrical Connection
- C - Drain Connection (1 1/2" NPT)
- D - Vent Collar - Optional
- E - Vent Cowl - Standard
- F - Machine Steam Inlet (3/4" NPT)
- G - Condensate Return (3/4" NPT)
- H - Steam Booster Electrical Connection (7/8" Hole)
- J - Booster Steam Inlet (1" NPT)
- K - Condensate Connection (3/4" NPT)
- L - Water Inlet for Booster (from Facility) (3/4" NPT, 110 °F)
- M - Water Outlet to Machine (3/4" NPT, 180 °F)

All dimensions from the floor can be increased 1" using the machine's adjustable feet.

Items in red are not supplied with the machine.

Items in blue are for the Steam option.

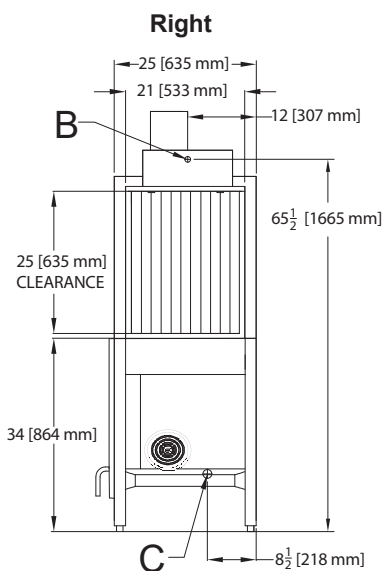
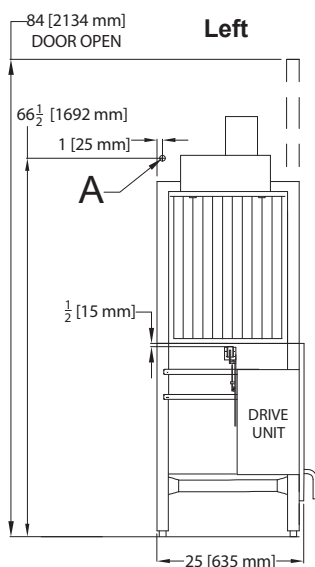
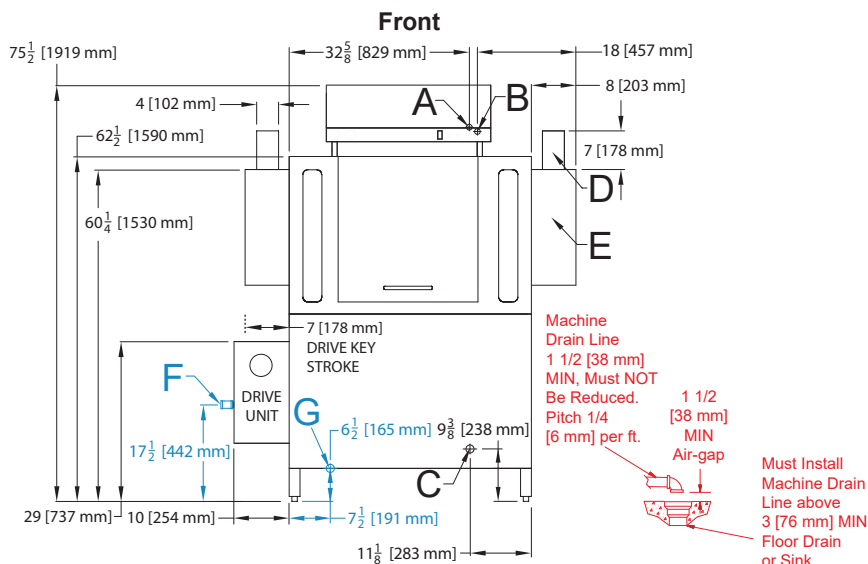
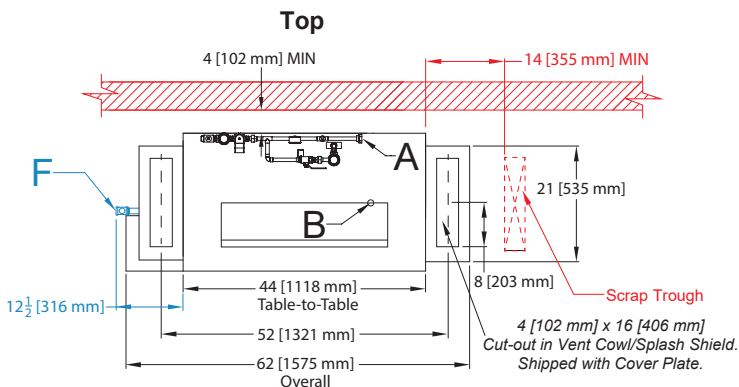

Steam Booster

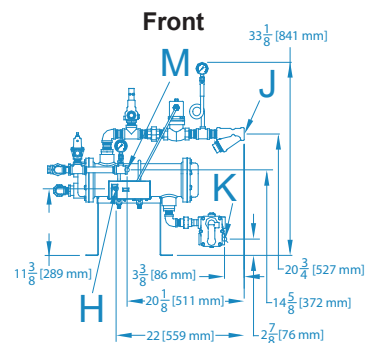
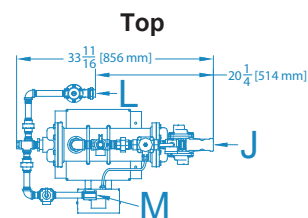

AJX-54 LEFT-TO-RIGHT

LEGEND

- A - Main Water Inlet
(3/4" NPT, 180 °F MIN)
- B - Electrical Connection
- C - Drain Connection (1 1/2" NPT)
- D - Vent Collar - Optional
- E - Vent Cowl - Standard
- F - Machine Steam Inlet (3/4" NPT)
- G - Condensate Return (3/4" NPT)
- H - Steam Booster Electrical Connection (7/8" Hole)
- J - Booster Steam Inlet (1" NPT)
- K - Condensate Connection (3/4" NPT)
- L - Water Inlet for Booster (from Facility)
(3/4" NPT, 110 °F)
- M - Water Outlet to Machine
(3/4" NPT, 180 °F)

All dimensions from the floor can be increased 1" using the machine's adjustable feet.

Items in red are not supplied with the machine.

Items in blue are for the Steam option.

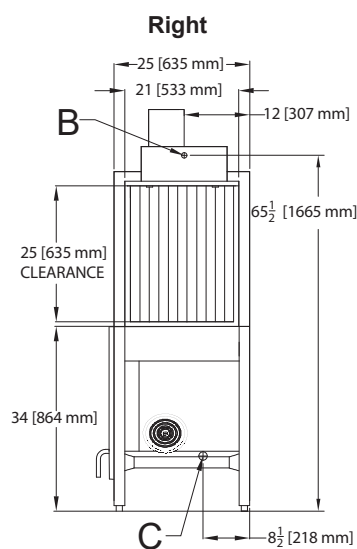
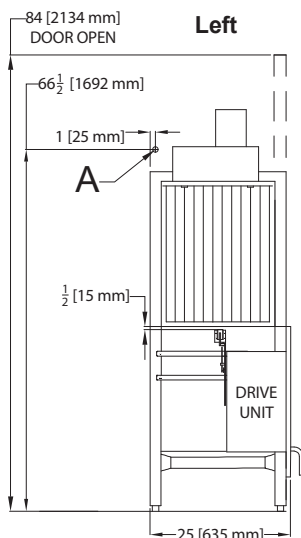
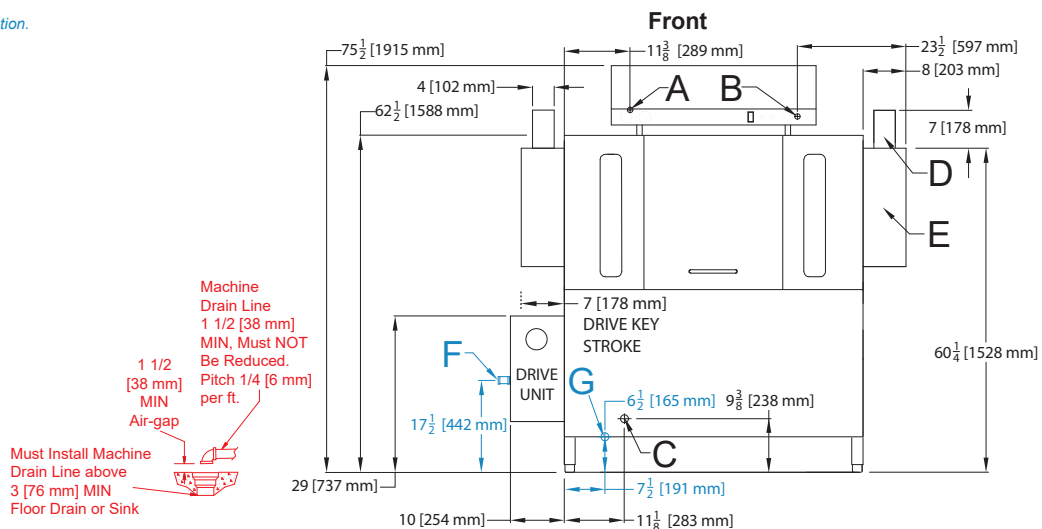
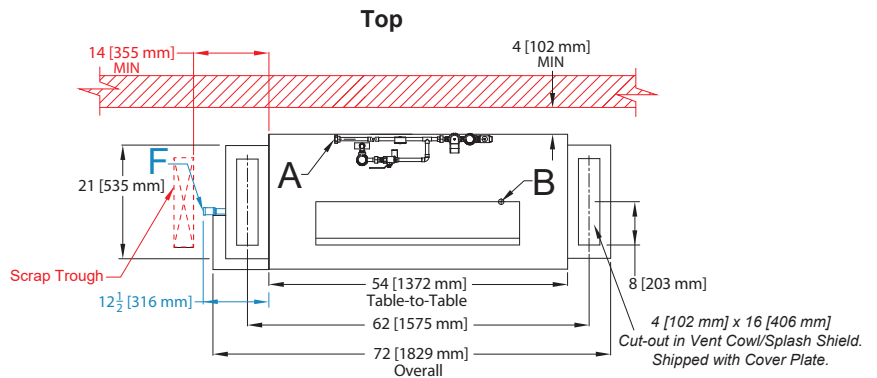

Steam Booster

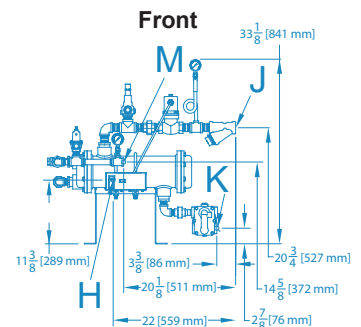
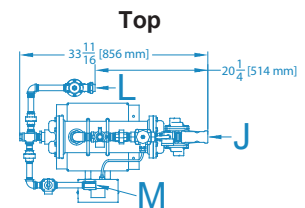

AJX-54 RIGHT-TO-LEFT

LEGEND

- A - Main Water Inlet (3/4" NPT, 180 °F MIN)
- B - Electrical Connection
- C - Drain Connection (1 1/2" NPT)
- D - Vent Collar - Optional
- E - Vent Cowl - Standard
- F - Machine Steam Inlet (3/4" NPT)
- G - Condensate Return (3/4" NPT)
- H - Steam Booster Electrical Connection (7/8" Hole)
- J - Booster Steam Inlet (1" NPT)
- K - Condensate Connection (3/4" NPT)
- L - Water Inlet for Booster (from Facility) (3/4" NPT, 110 °F)
- M - Water Outlet to Machine (3/4" NPT, 180 °F)

All dimensions from the floor can be increased 1" using the machine's adjustable feet.

Items in red are not supplied with the machine.

Items in blue are for the Steam option.

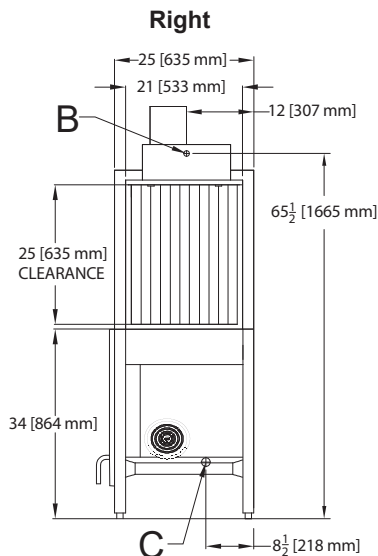
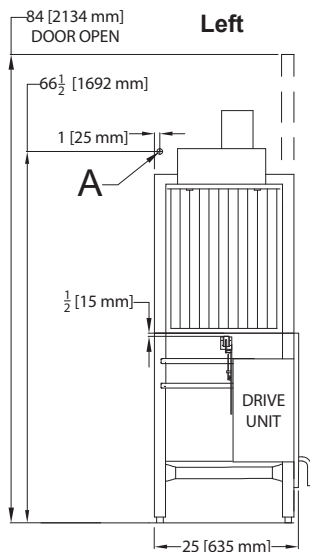
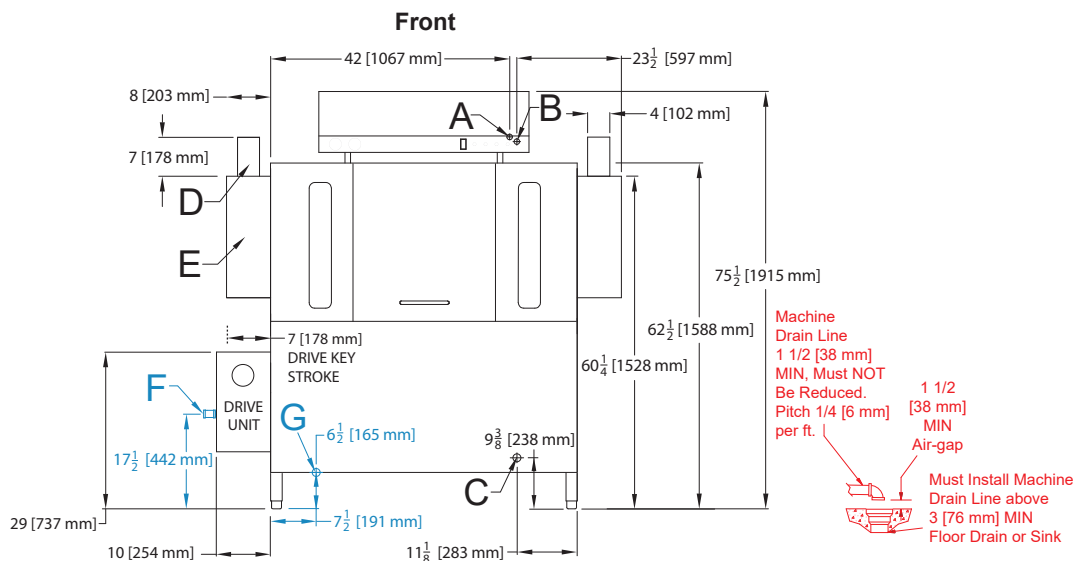
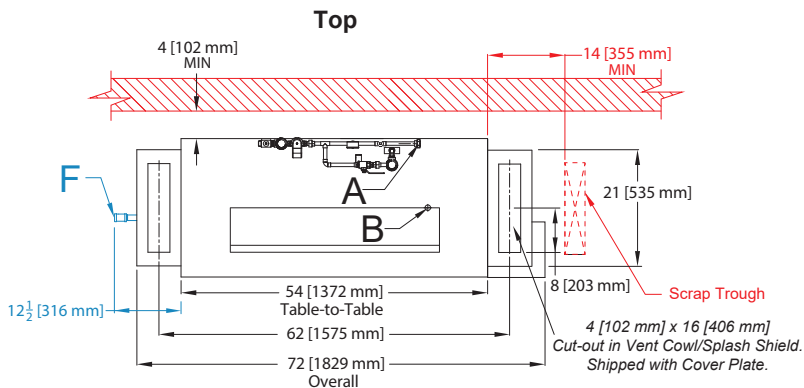

Steam Booster

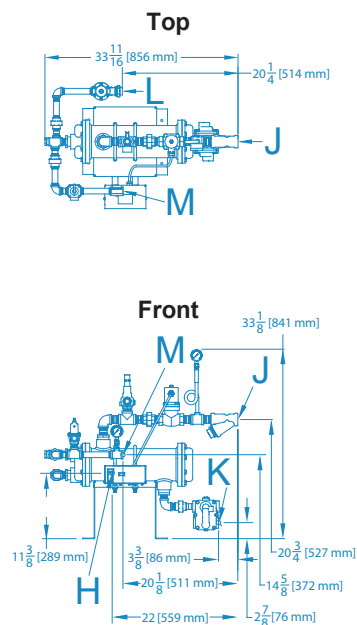

AJX-66 LEFT-TO-RIGHT

LEGEND

- A - Water Inlet
(3/4" NPT, 110-140 °F MIN)
- B - Electrical Connection
- C - Drain Connection (1 1/2" NPT)
- D - Vent Collar - Optional
- E - Vent Cowl - Standard
- F - Machine Steam Inlet (3/4" NPT)
- G - Condensate Return (3/4" NPT)
- H - Steam Booster Electrical Connection
(7/8" Hole)
- J - Booster Steam Inlet (1" NPT)
- K - Condensate Connection (3/4" NPT)
- L - Water Inlet for Booster (from Facility)
(3/4" NPT, 110 °F)
- M - Water Outlet to Machine
(3/4" NPT, 180 °F)
- N - Pre-wash Water Inlet
(3/4" NPT, 110-140 °F)
- P - Cold Water Thermostat - Optional
(3/4" NPT)

All dimensions from the floor can be increased 1" using the machine's adjustable feet.

Items in red are not supplied with the machine.

Items in blue are for the Steam option.

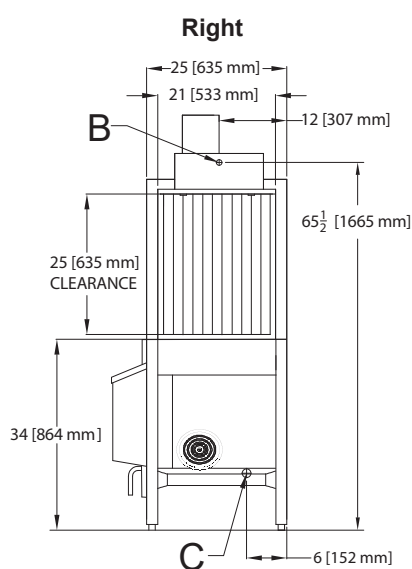
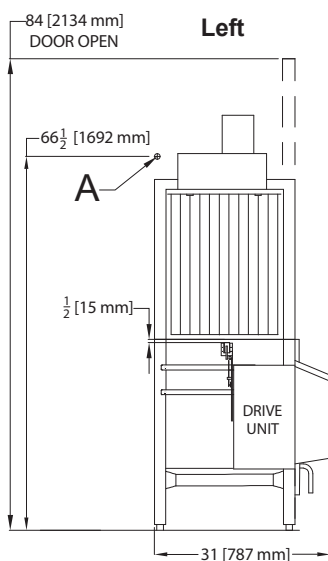
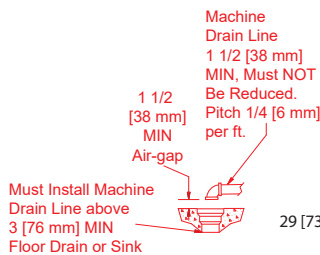
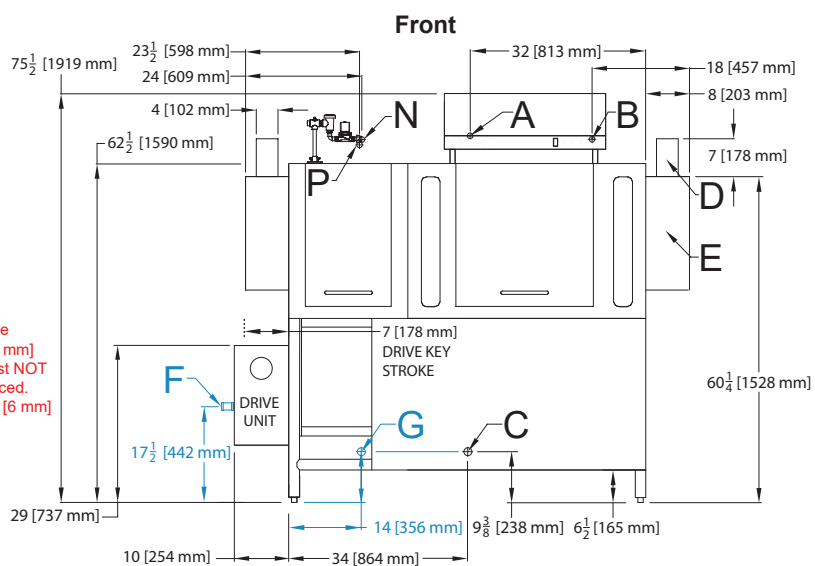
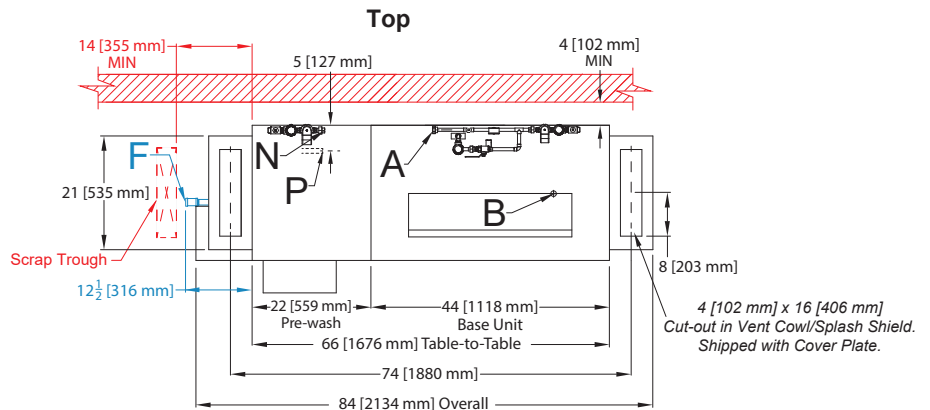

Steam Booster

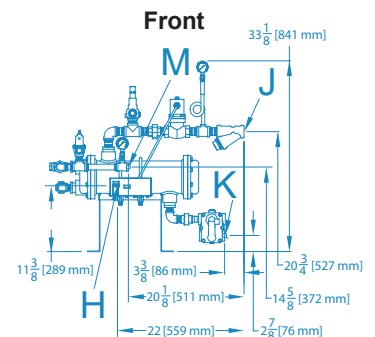
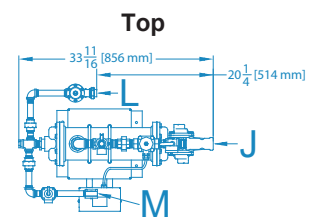

AJX-66 RIGHT-TO-LEFT

LEGEND

- A - Water Inlet (3/4" NPT, 110–140 °F MIN)
- B - Electrical Connection
- C - Drain Connection (1 1/2" NPT)
- D - Vent Collar - Optional
- E - Vent Cowl - Standard
- F - Machine Steam Inlet (3/4" NPT)
- G - Condensate Return (3/4" NPT)
- H - Steam Booster Electrical Connection (7/8" Hole)
- J - Booster Steam Inlet (1" NPT)
- K - Condensate Connection (3/4" NPT)
- L - Water Inlet for Booster (from Facility) (3/4" NPT, 110 °F)
- M - Water Outlet to Machine (3/4" NPT, 180 °F)
- N - Pre-wash Water Inlet (3/4" NPT, 110–140 °F)
- P - Cold Water Thermostat - Optional (3/4" NPT)

All dimensions from the floor can be increased 1" using the machine's adjustable feet.

Items in red are not supplied with the machine.

Items in blue are for the Steam option.

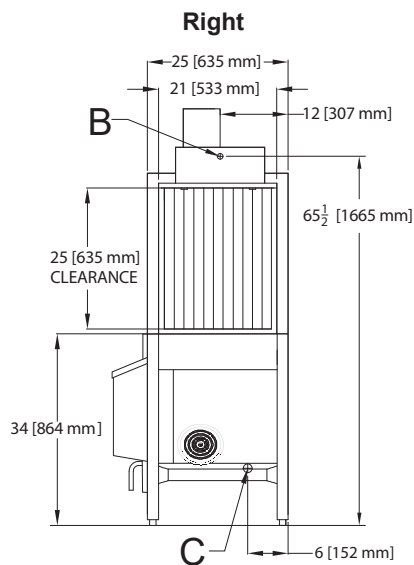
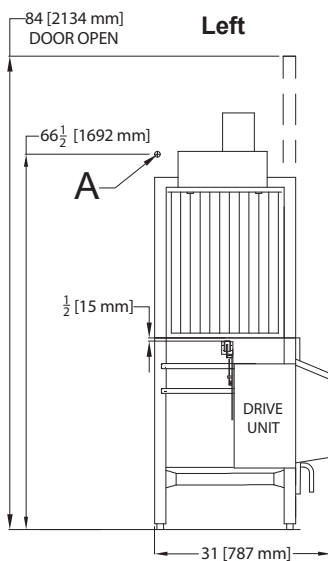
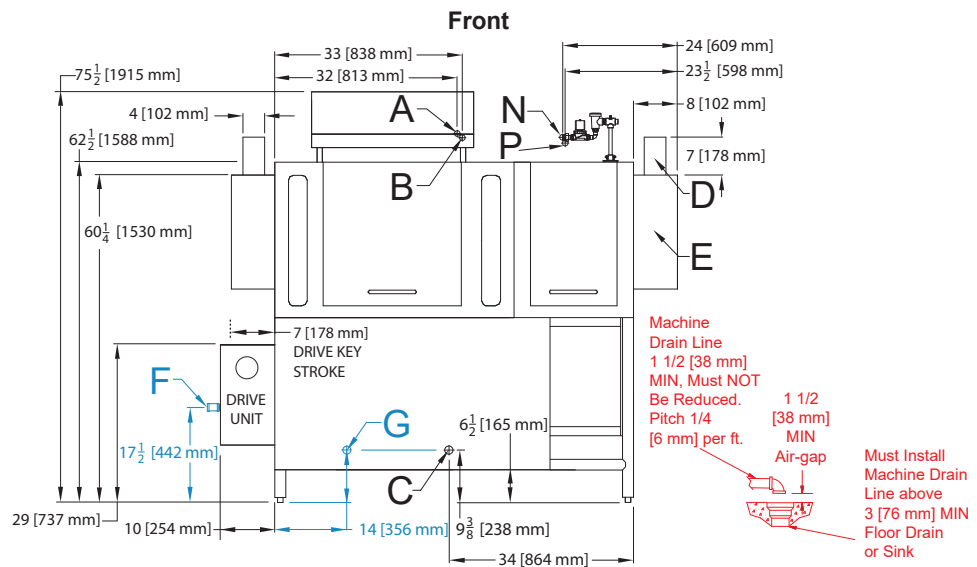
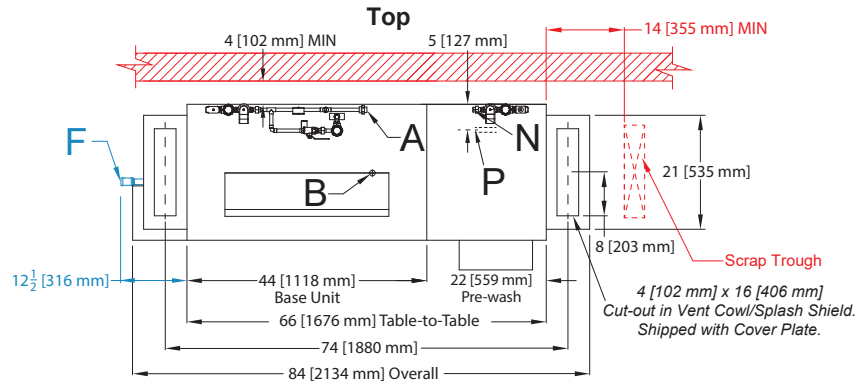

Steam Booster

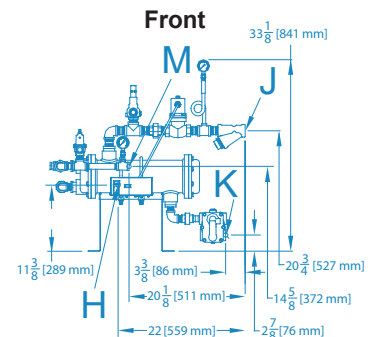
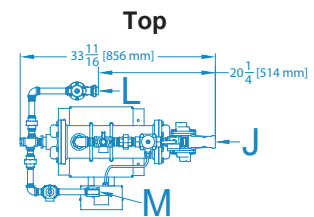

AJX-76 LEFT-TO-RIGHT

LEGEND

- A - Water Inlet
(3/4" NPT, 110-140 °F MIN)
- B - Electrical Connection
- C - Drain Connection (1 1/2" NPT)
- D - Vent Collar - Optional
- E - Vent Cowl - Standard
- F - Machine Steam Inlet (3/4" NPT)
- G - Condensate Return (3/4" NPT)
- H - Steam Booster Electrical Connection
(7/8" Hole)
- J - Booster Steam Inlet (1" NPT)
- K - Condensate Connection (3/4" NPT)
- L - Water Inlet for Booster (from Facility)
(3/4" NPT, 110 °F)
- M - Water Outlet to Machine
(3/4" NPT, 180 °F)
- N - Pre-wash Water Inlet
(3/4" NPT, 110-140 °F)
- P - Cold Water Thermostat - Optional
(3/4" NPT)

All dimensions from the floor can be increased 1" using the machine's adjustable feet.

Items in red are not supplied with the machine.

Items in blue are for the Steam option.

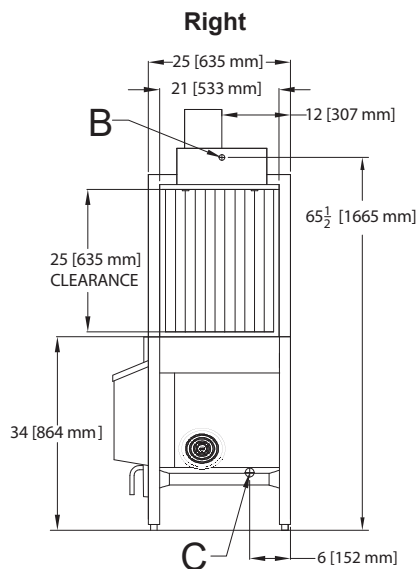
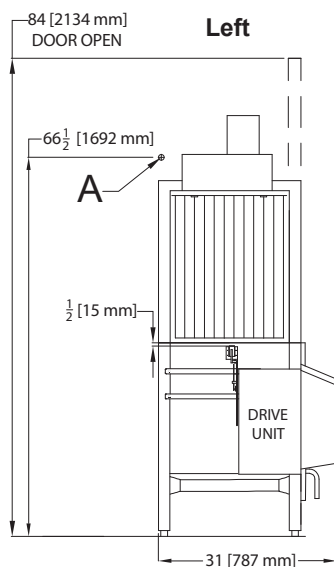
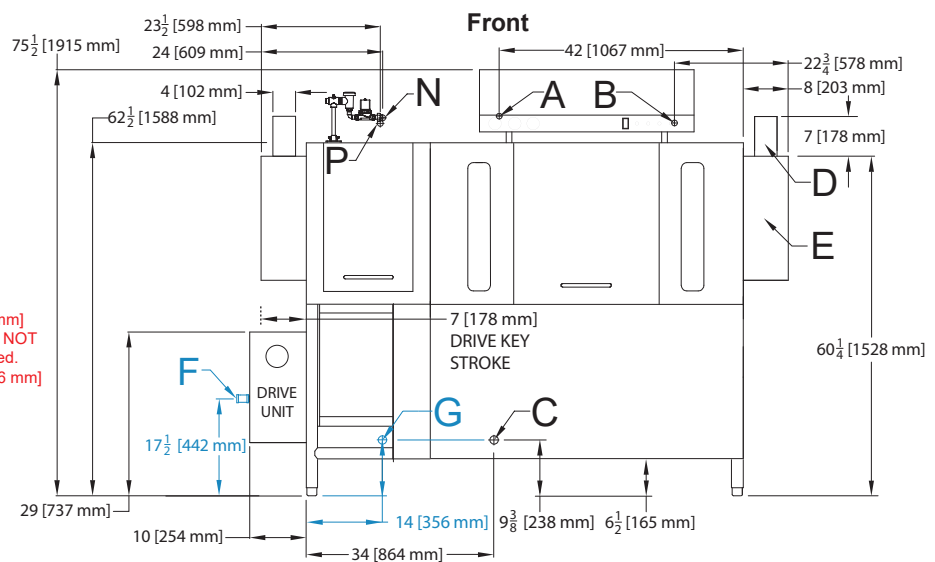
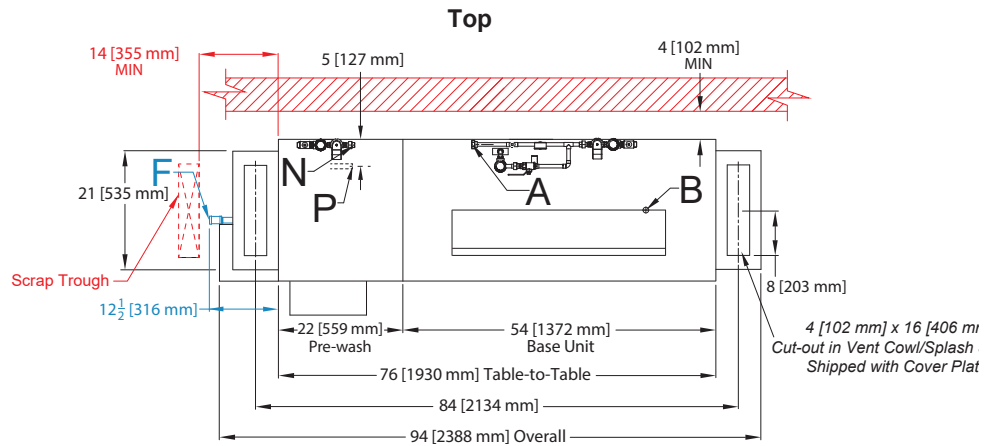
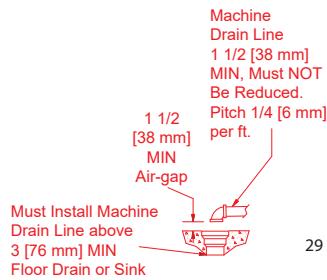

Steam Booster

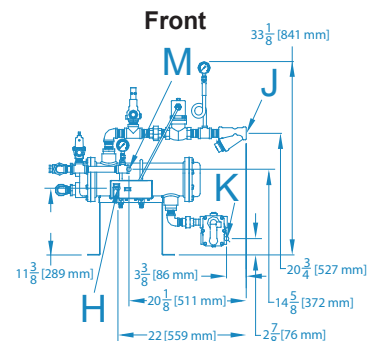
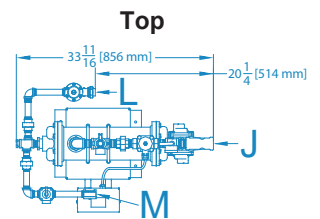

AJX-76 RIGHT-TO-LEFT

LEGEND

- A - Water Inlet (3/4" NPT, 110-140 °F MIN)
- B - Electrical Connection
- C - Drain Connection (1 1/2" NPT)
- D - Vent Collar - Optional
- E - Vent Cowl - Standard
- F - Machine Steam Inlet (3/4" NPT)
- G - Condensate Return (3/4" NPT)
- H - Steam Booster Electrical Connection (7/8" Hole)
- J - Booster Steam Inlet (1" NPT)
- K - Condensate Connection (3/4" NPT)
- L - Water Inlet for Booster (from Facility) (3/4" NPT, 110 °F)
- M - Water Outlet to Machine (3/4" NPT, 180 °F)
- N - Pre-wash Water Inlet (3/4" NPT, 110-140 °F)
- P - Cold Water Thermostat - Optional (3/4" NPT)

All dimensions from the floor can be increased 1" using the machine's adjustable feet.

Items in red are not supplied with the machine.

Items in blue are for the Steam option.

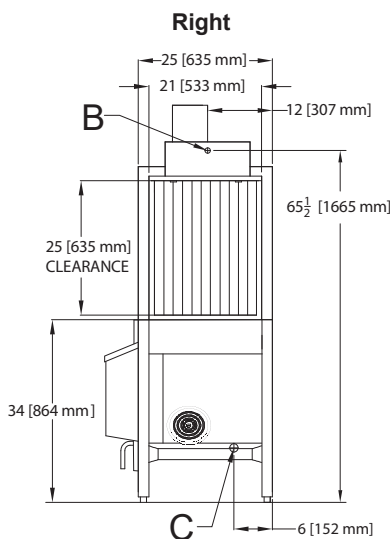
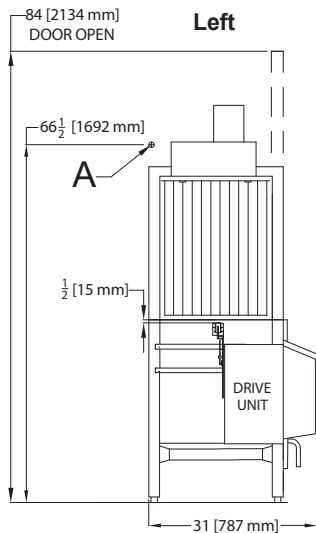
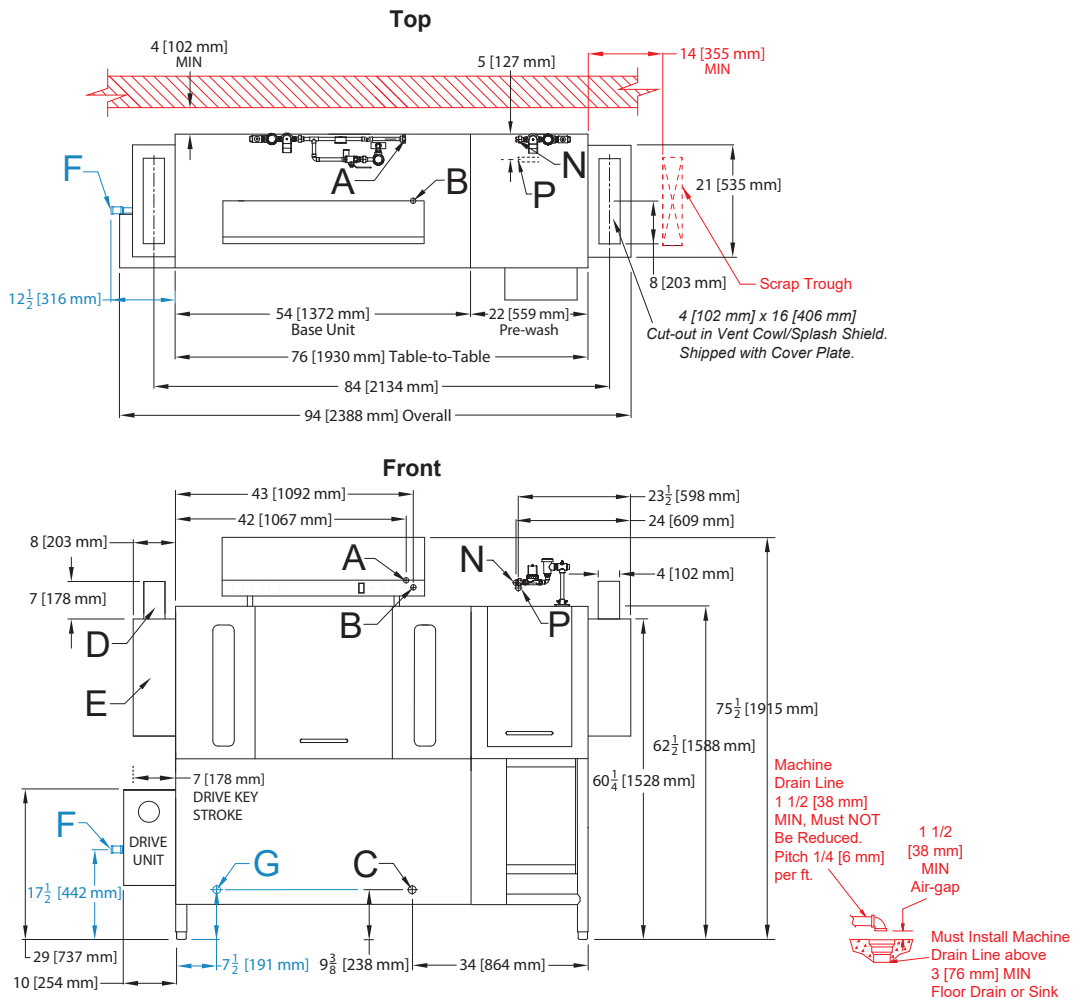

Steam Booster

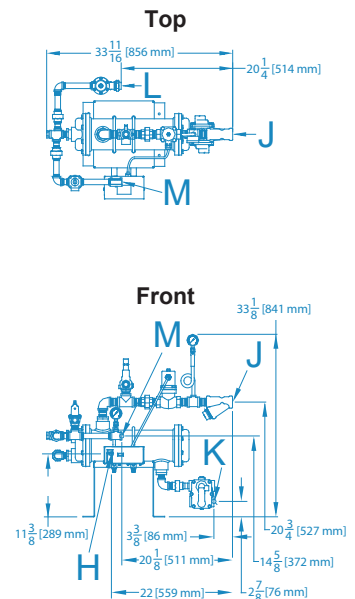

AJX-80 LEFT-TO-RIGHT

LEGEND

- A - Water Inlet
(3/4" NPT, 110-140 °F MIN)
- B - Electrical Connection
- C - Drain Connection (1 1/2" NPT)
- D - Vent Collar - Optional
- E - Vent Cowl - Standard
- F - Machine Steam Inlet (3/4" NPT)
- G - Condensate Return (3/4" NPT)
- H - Steam Booster Electrical Connection
(7/8" Hole)
- J - Booster Steam Inlet (1" NPT)
- K - Condensate Connection (3/4" NPT)
- L - Water Inlet for Booster (from Facility)
(3/4" NPT, 110 °F)
- M - Water Outlet to Machine
(3/4" NPT, 180 °F)
- N - Pre-wash Water Inlet
(3/4" NPT, 110-140 °F)
- P - Cold Water Thermostat - Optional
(3/4" NPT)

All dimensions from the floor can be increased 1" using the machine's adjustable feet.

Items in red are not supplied with the machine.

Items in blue are for the Steam option.

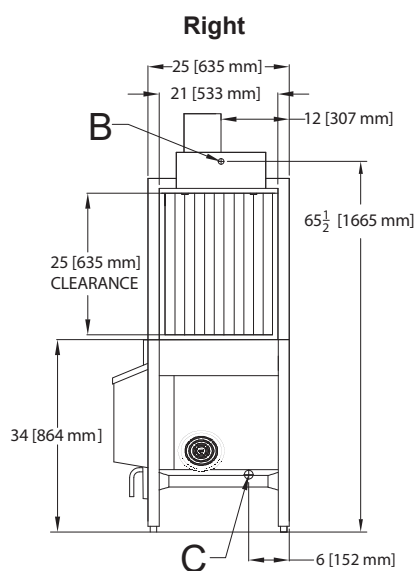
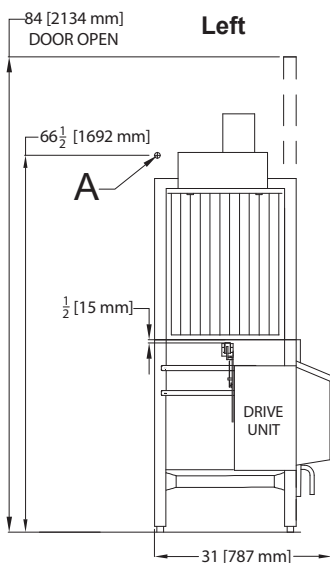
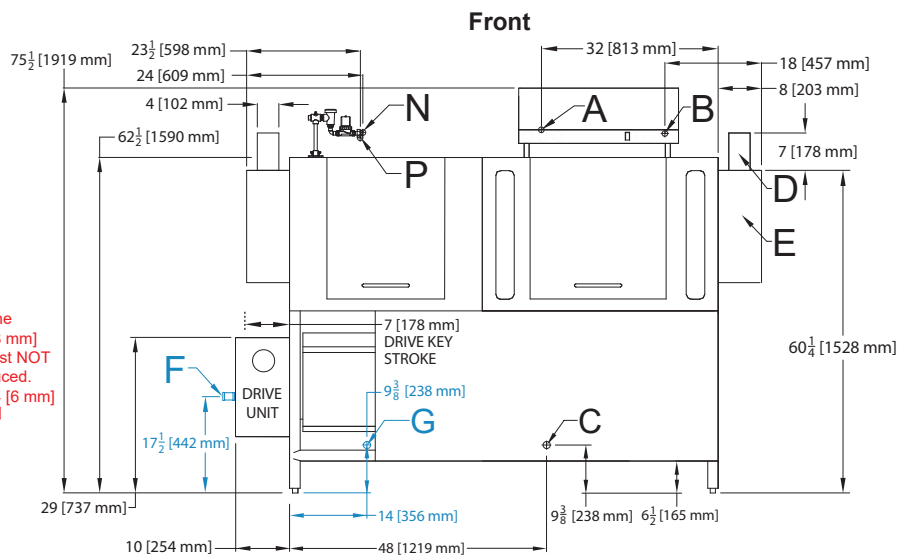
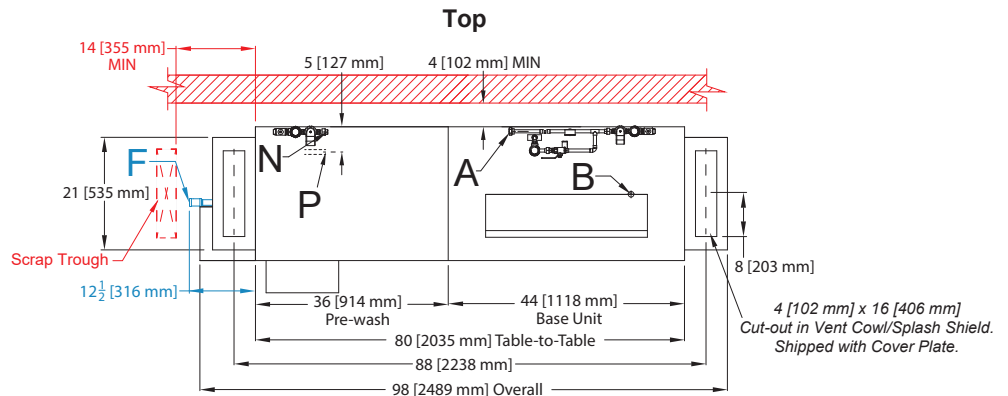

Steam Booster

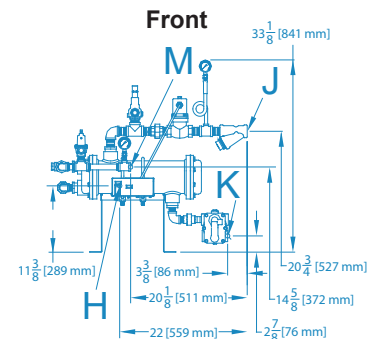
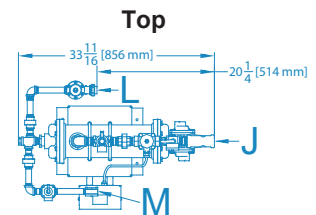

AJX-80 RIGHT-TO-LEFT

LEGEND

- A - Water Inlet (3/4" NPT, 110–140 °F MIN)
- B - Electrical Connection
- C - Drain Connection (1 1/2" NPT)
- D - Vent Collar - Optional
- E - Vent Cowl - Standard
- F - Machine Steam Inlet (3/4" NPT)
- G - Condensate Return (3/4" NPT)
- H - Steam Booster Electrical Connection (7/8" Hole)
- J - Booster Steam Inlet (1" NPT)
- K - Condensate Connection (3/4" NPT)
- L - Water Inlet for Booster (from Facility) (3/4" NPT, 110 °F)
- M - Water Outlet to Machine (3/4" NPT, 180 °F)
- N - Pre-wash Water Inlet (3/4" NPT, 110–140 °F)
- P - Cold Water Thermostat - Optional (3/4" NPT)

All dimensions from the floor can be increased 1" using the machine's adjustable feet.

Items in red are not supplied with the machine.

Items in blue are for the Steam option.

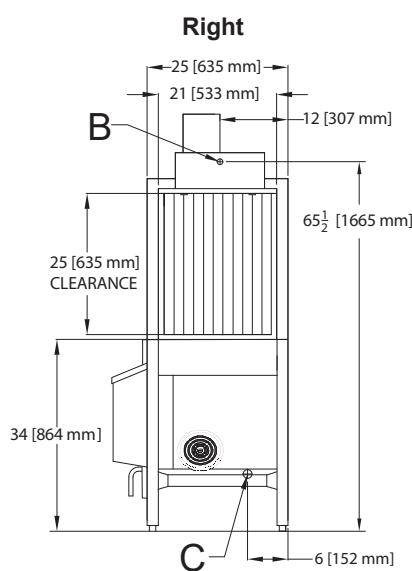
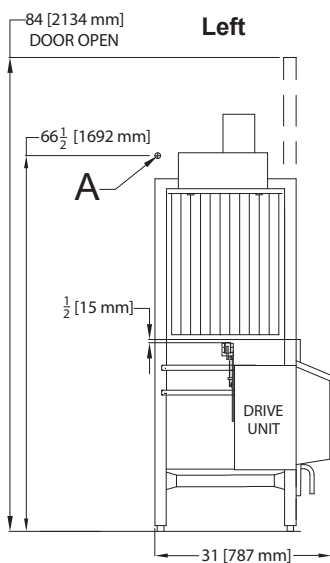
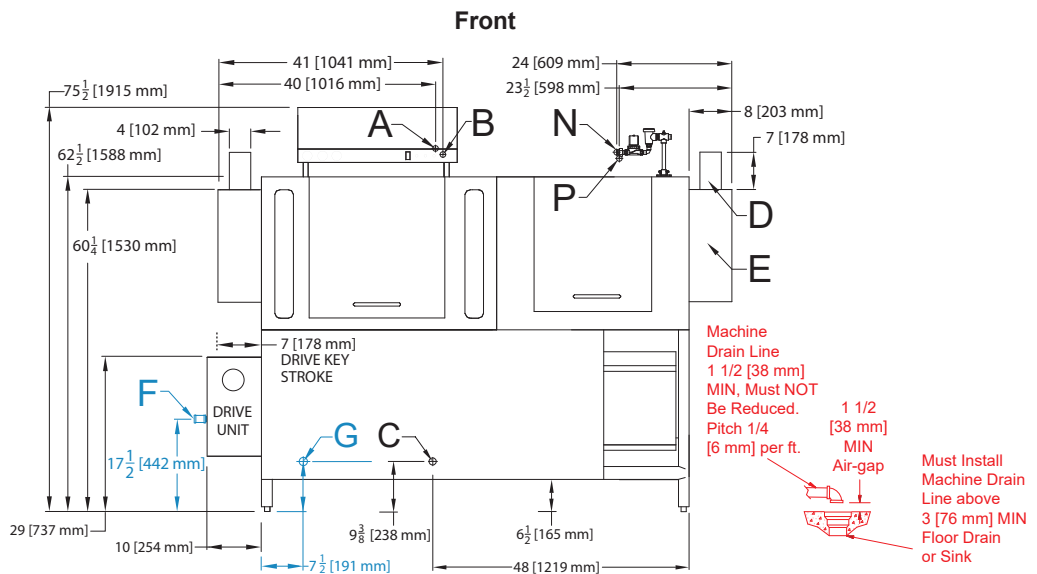
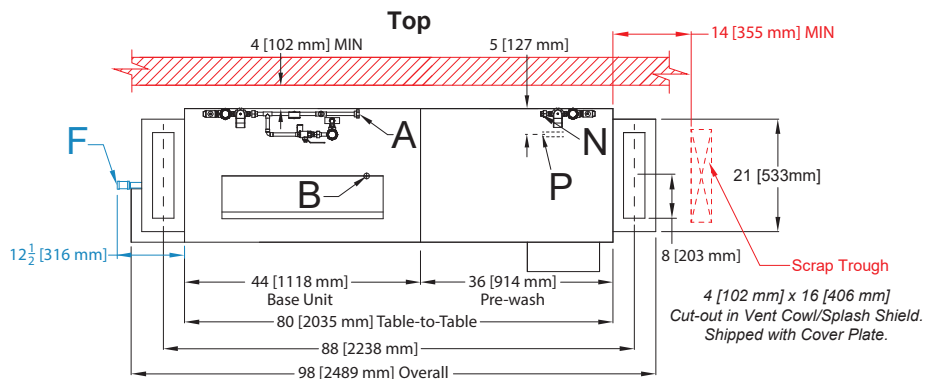

Steam Booster

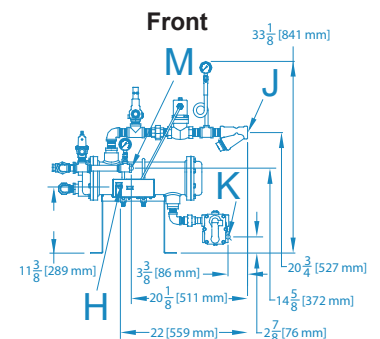
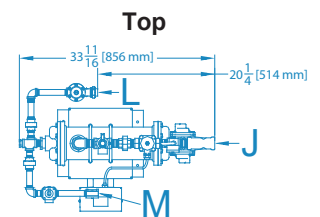

AJX-90 LEFT-TO-RIGHT

LEGEND

- A - Water Inlet (3/4" NPT, 110-140 °F MIN)
- B - Electrical Connection
- C - Drain Connection (1 1/2" NPT)
- D - Vent Collar - Optional
- E - Vent Cowl - Standard
- F - Machine Steam Inlet (3/4" NPT)
- G - Condensate Return (3/4" NPT)
- H - Steam Booster Electrical Connection (7/8" Hole)
- J - Booster Steam Inlet (1" NPT)
- K - Condensate Connection (3/4" NPT)
- L - Water Inlet for Booster (from Facility) (3/4" NPT, 110 °F)
- M - Water Outlet to Machine (3/4" NPT, 180 °F)
- N - Pre-wash Water Inlet (3/4" NPT, 110-140 °F)
- P - Cold Water Thermostat - Optional (3/4" NPT)

All dimensions from the floor can be increased 1" using the machine's adjustable feet.

Items in red are not supplied with the machine.

Items in blue are for the Steam option.

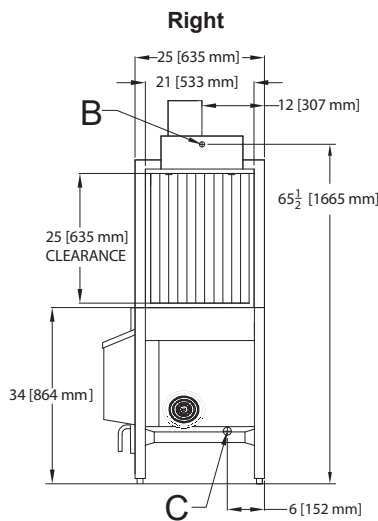
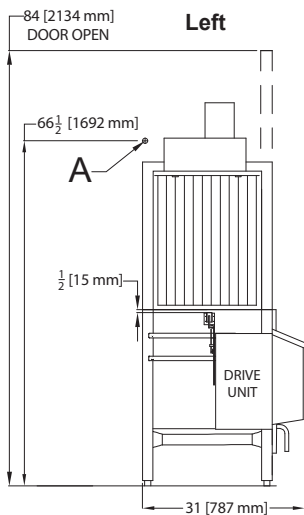
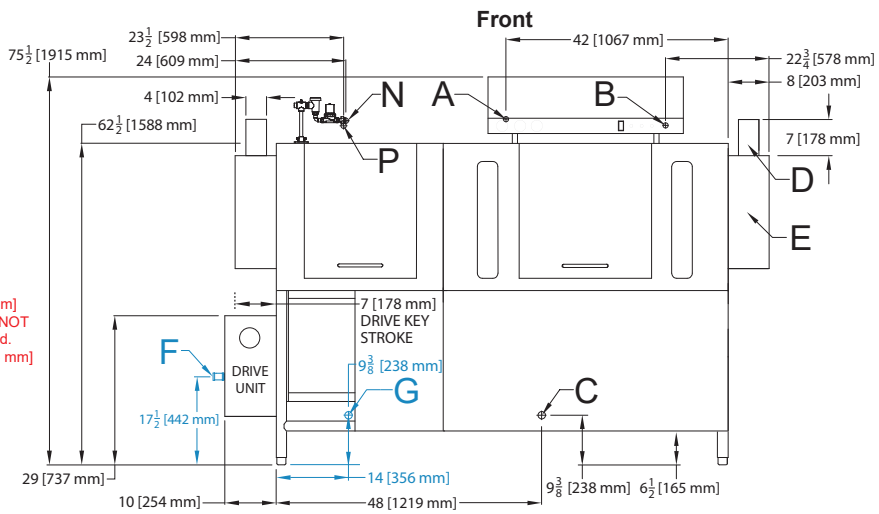
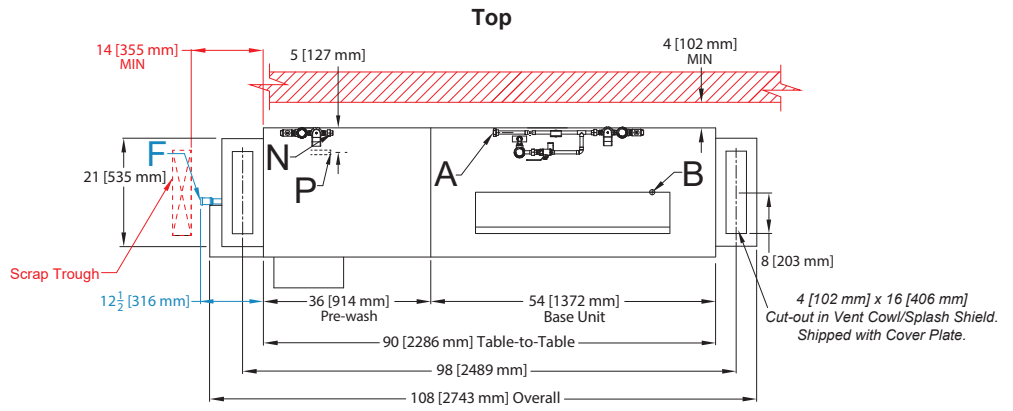
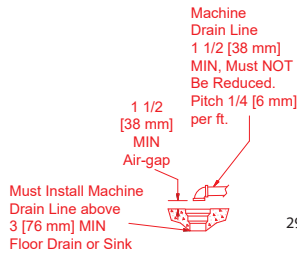

Steam Booster

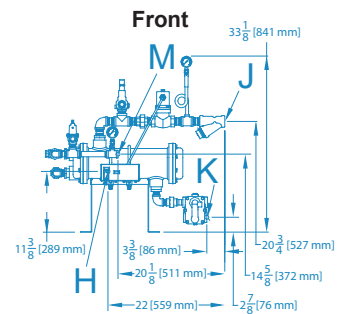
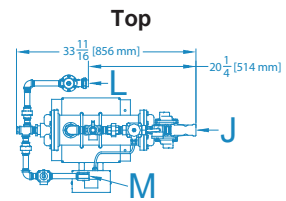

AJX-90 RIGHT-TO-LEFT

LEGEND

- A - Water Inlet (3/4" NPT, 110-140 °F MIN)
- B - Electrical Connection
- C - Drain Connection (1 1/2" NPT)
- D - Vent Collar - Optional
- E - Vent Cowl - Standard
- F - Machine Steam Inlet (3/4" NPT)
- G - Condensate Return (3/4" NPT)
- H - Steam Booster Electrical Connection (7/8" Hole)
- J - Booster Steam Inlet (1" NPT)
- K - Condensate Connection (3/4" NPT)
- L - Water Inlet for Booster (from Facility) (3/4" NPT, 110 °F)
- M - Water Outlet to Machine (3/4" NPT, 180 °F)
- N - Pre-wash Water Inlet (3/4" NPT, 110-140 °F)
- P - Cold Water Thermostat - Optional (3/4" NPT)

All dimensions from the floor can be increased 1" using the machine's adjustable feet.

Items in red are not supplied with the machine.

Items in blue are for the Steam option.

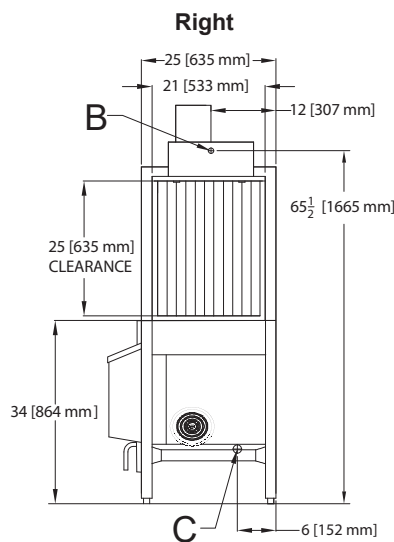
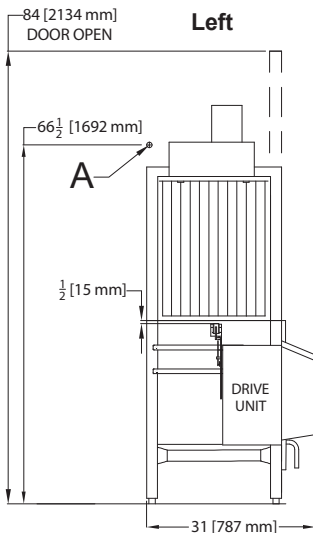
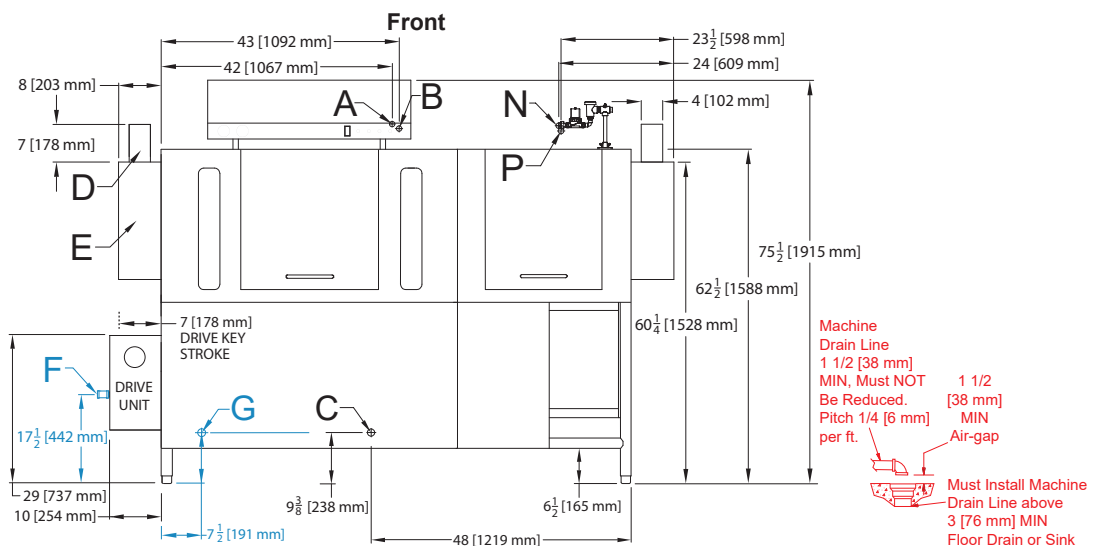
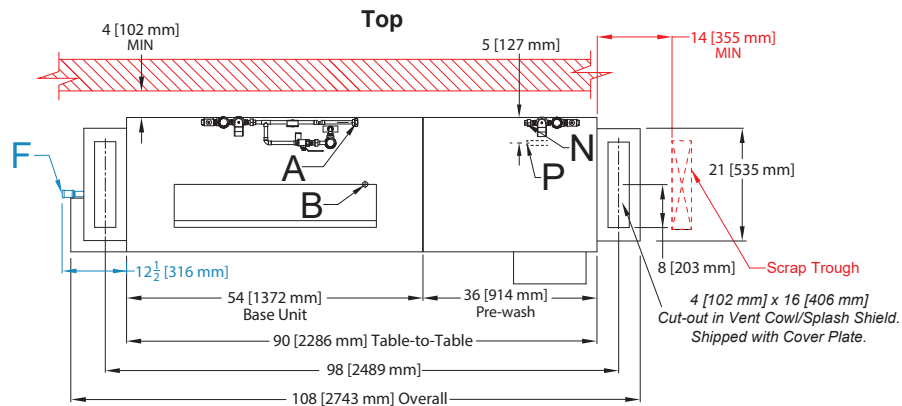

Steam Booster

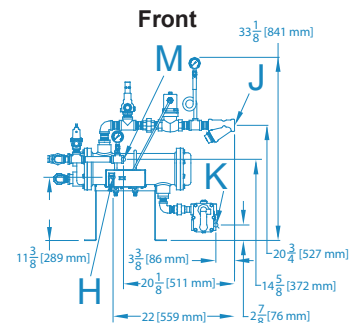
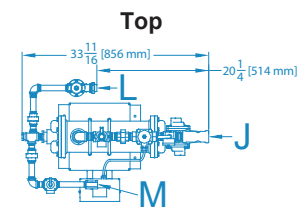

SIDE-LOADER LEFT-TO-RIGHT

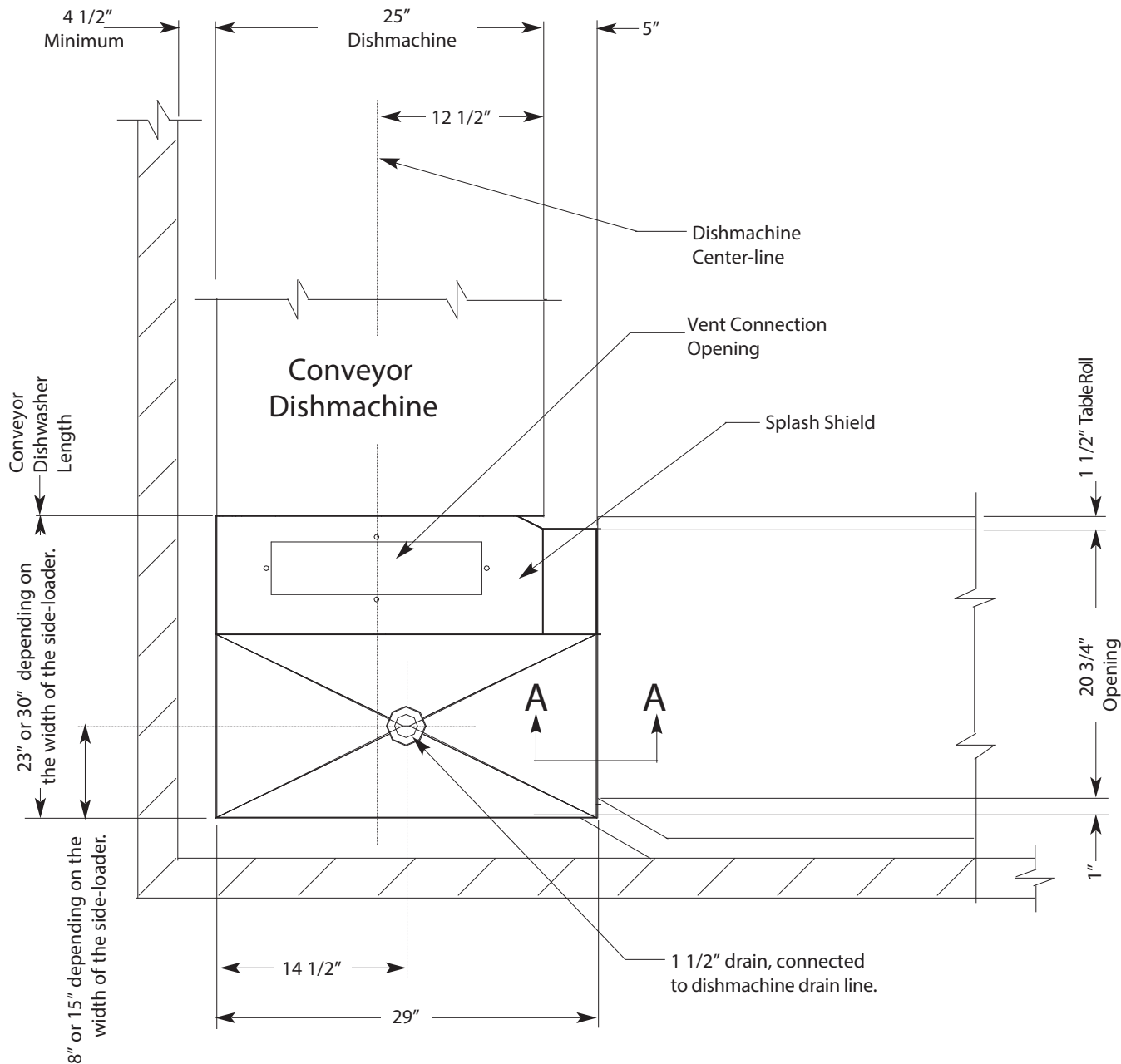

Section A-A

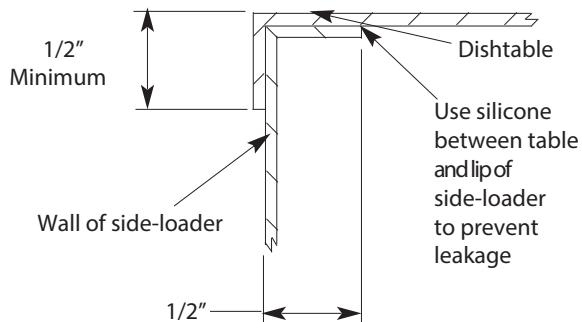

SIDE-LOADER RIGHT-TO-LEFT

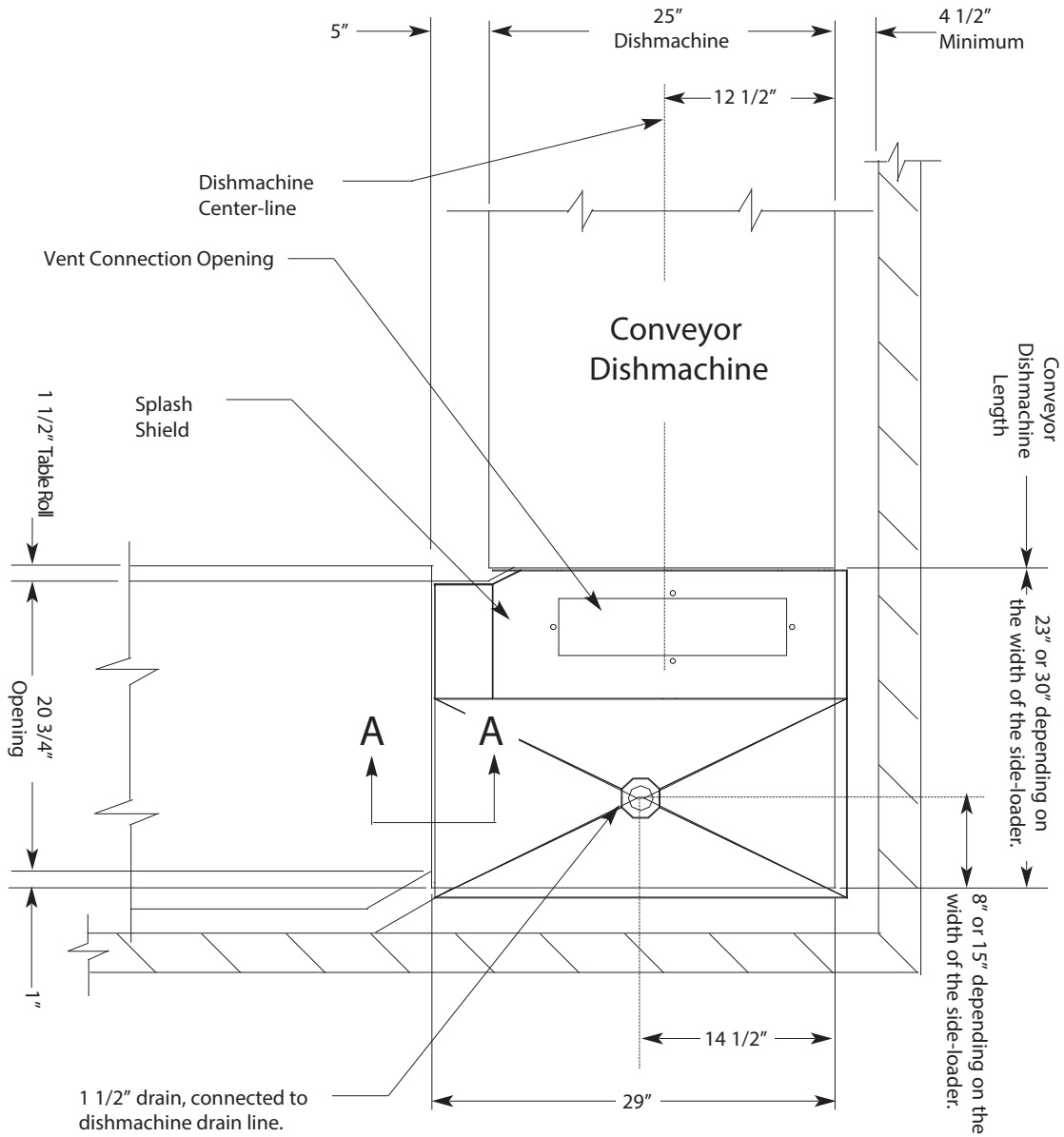

Section A-A

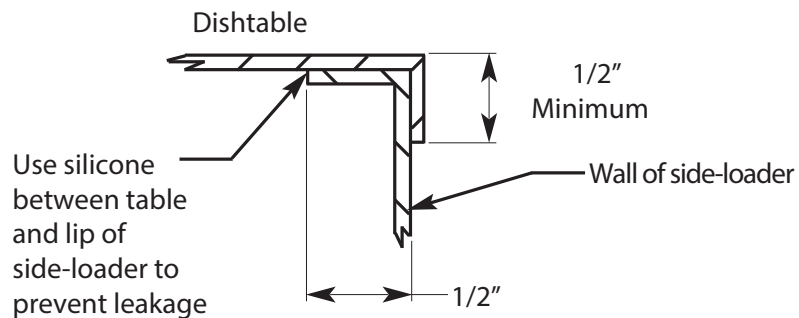

SPECIFICATIONS

SIDE-LOADER & TABLE INSTALL

23" SIDE-LOADER DIMENSIONS		30" SIDE-LOADER DIMENSIONS	
MODEL	DIMENSIONS	MODEL	DIMENSIONS
AJX-44	75"	AJX-44	82"
AJX-66	97"	AJX-66	104"
AJX-80	111"	AJX-80	118"

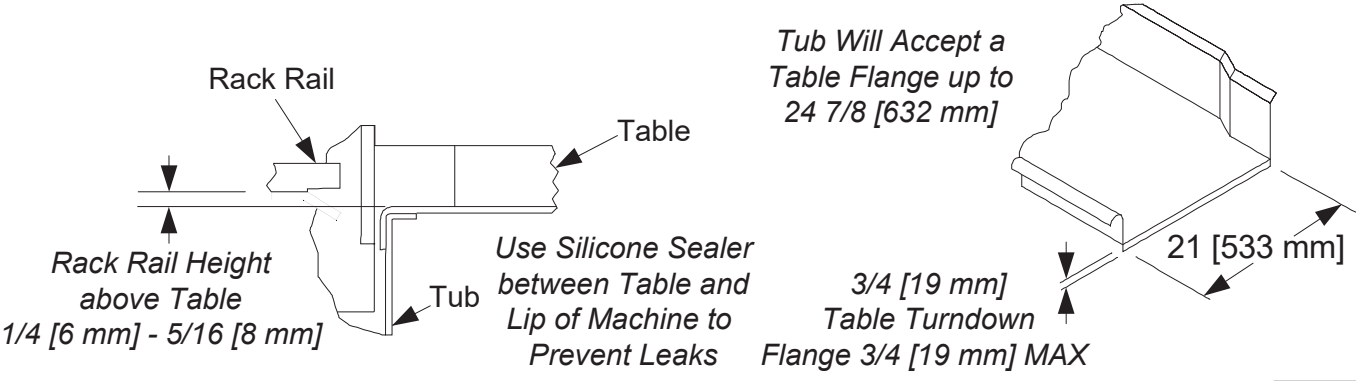
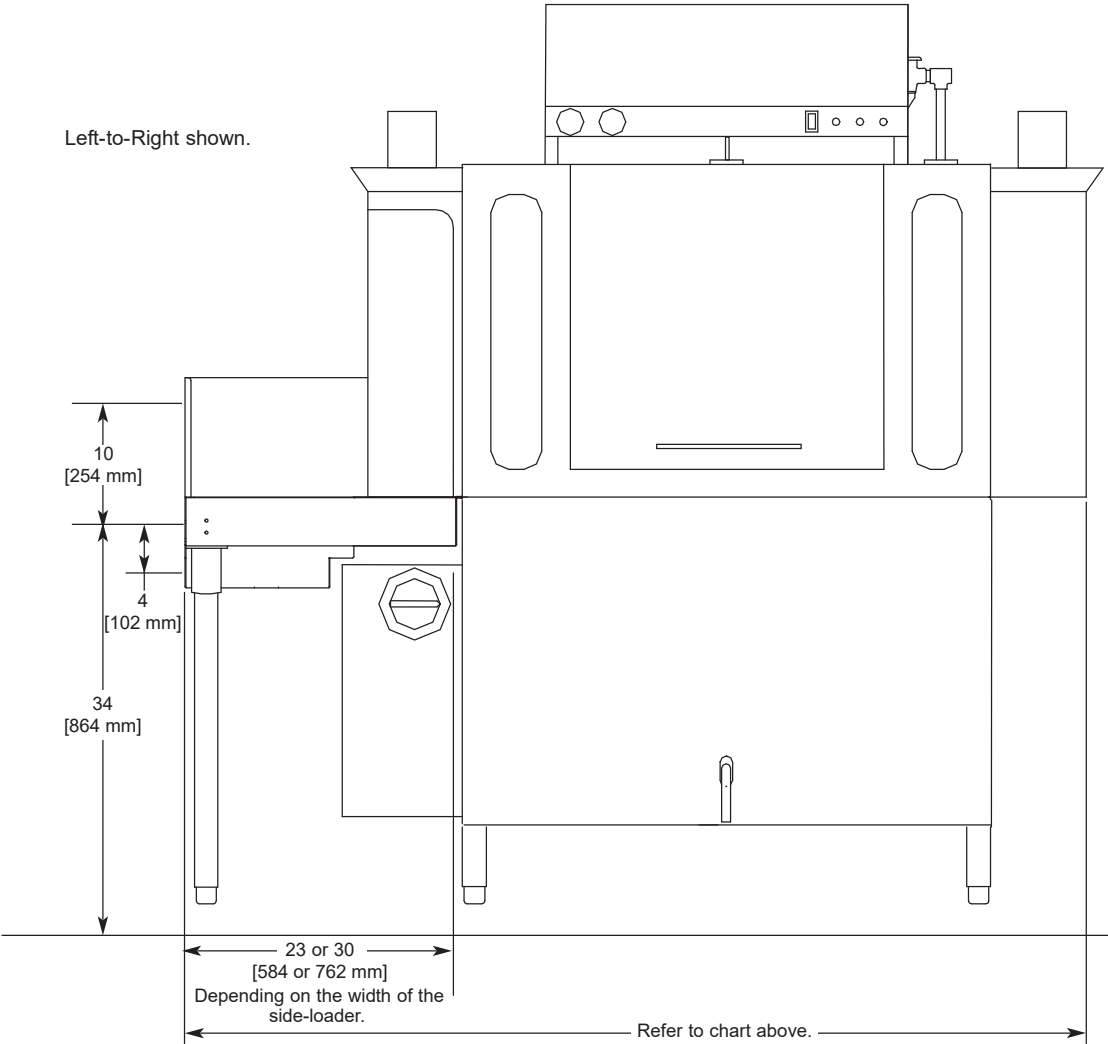

OPERATING SPECIFICATIONS

High-temp

Racks per Hour	225
Dishes per Hour	5625
Glasses per Hour	8100

Low-temp

Racks per Hour	209
Dishes per Hour	5225
Glasses per Hour	7524

Pre-wash

Tank Capacity (Gallons)	17.25
Pump Capacity, AJX-66/76 (GPM)	120
Pump Capacity, AJX-80/90 (GPM)	270

Wash

Tank Capacity (Gallons)	20.4
Pump Capacity, All Models (GPM)	270

Ventilation Requirements (CFM)

Input End	200
Output End	400
Total	600

Steam Requirements

Steam Connection (NPT)	3/4"
Steam Flow Pressure (PSI)	10-30
Consumption at 15 PSI (lbs/hr)	60

Conveyor Speed (FPM)

High-temp	6.2
Low-temp	5.75

Gallons per Rack

High-temp	0.68
Low-temp	0.78

Motor Characteristics

Drive Motor (HP)	1/4
Wash Motor (HP)	2
Pre-wash Motor, AJX-66/76 (HP)	1
Pre-wash Motor, AJX-80/90 (HP)	2

WATER REQUIREMENTS

High-temp

Minimum Wash Temperature (°F/°C)	160/71
Minimum Rinse Temperature (°F/°C)	180/82
Pre-wash Temperature (°F/°C)	110-140/43-60
Flow Pressure (PSI)	15
Flow Rate (GPM)	2.57
Water Line Size (NPT)	1/2"
Drain Line Size (NPT)	1 1/2"

Low-temp

Minimum Wash Temperature (°F/°C)	140/60
Minimum Rinse Temperature (°F/°C)	140/60
Pre-wash Temperature (°F/°C)	110-140/43-60
Flow Pressure (PSI)	15
Flow Rate (GPM)	2.74
Water Line Size (NPT)	1/2"
Drain Line Size (NPT)	1 1/2"
Minimum Chlorine Required (PPM)	50

NOTICE



Always refer to the machine data plate for specific electrical and water requirements. The material provided on this page is for reference only and is subject to change without notice.



All electrical ratings provided in this manual are for reference only. Always refer to the machine data plate to get the exact electrical information for this machine. **All electrical work performed on machines should be done in accordance with applicable local, state, territorial, and national codes.** Work should only be performed by qualified electricians and authorized service agents. A list of authorized Service Agencies is located in the back of this manual.

Note that all electrical wiring used in the dishmachine must be rated, at a minimum, for 212 °F (100 °C), and that only copper conductors must be used.

Where applicable, heating element amperage draws have been adjusted for the assumed input voltage. The manufacturer assumes incoming voltages will be either 208, 230, or 460 Volts. Some of the heating elements used in our machines are actually rated for other voltages, such as 240 or 480 Volts. Always verify the amperage draw of the machine in operation when sizing circuit protection.

Amperage loads for machine motors and heaters are listed on the data plate. If the machine is equipped with a third-party booster heater, note the booster heater has its own electrical connection and requires a separate service (consult booster manufacturer).

The electrical configurations of the machines are as follows:

Available Electrical Characteristics:

- 208 V, 60 Hz, Single-phase
- 230 V, 60 Hz, Single-phase
- 208 V, 60 Hz, Three-phase
- 230 V, 60 Hz, Three-phase
- 380 V, 50 Hz, Three-phase
- 460 V, 60 Hz, Three-phase

Available Wash Tank Heaters:

- 18 kW

Available Booster Heaters:

- Third-party External Boosters

NOTICE Local codes may require more stringent protection than what is displayed here and on the data plate. Always verify with your electrical service contractor that your circuit protection is adequate and meets all applicable national and local codes. Numbers in this manual are for reference and may change without notice.

NOTICE On three-phase machines, imbalanced wild leg goes to L3. Also see the Motor Rotation section.

NOTICE Information below is for machine components only. If using a third-party external booster, consult booster manufacturer for booster information. For steam booster information, see Steam Line Connections section.



AJX-44/54CE

Volts	Phase	Freq	Wash Motor	Drive Motor	Wash Heater	Total Load	MCA	MOP
208	1	60 Hz	8.7 A	1.8 A	86.5 A	97.0 A	99.2 A	105 A
230	1	60 Hz	9.6 A	1.8 A	71.9 A	83.3 A	85.7 A	95 A
208	3	60 Hz	5.8 A	1.2 A	50.0 A	57.0 A	58.4 A	60 A
230	3	60 Hz	5.7 A	1.1 A	41.5 A	48.3 A	49.7 A	55 A
380	3	50 Hz	5.1 A	0.9 A	27.3 A	33.3 A	34.6 A	40 A
460	3	60 Hz	2.9 A	0.6 A	20.7 A	24.1 A	24.9 A	30 A
600	3	60 Hz	2.1 A	0.4 A	17.3 A	19.8 A	20.4 A	25 A

AJX-44/54CS

Volts	Phase	Freq	Wash Motor	Drive Motor	Wash Heater	Total Load	MCA	MOP
208	1	60 Hz	8.7 A	1.8 A	N/A	10.5 A	12.7 A	20 A
230	1	60 Hz	9.6 A	1.8 A	N/A	11.4 A	13.8 A	20 A
208	3	60 Hz	5.8 A	1.2 A	N/A	7.0 A	8.5 A	15 A
230	3	60 Hz	5.7 A	1.1 A	N/A	6.8 A	8.2 A	15 A

AJX-66/76CE

Volts	Phase	Freq	Pre-wash Motor	Wash Motor	Drive Motor	Wash Heater	Total Load	MCA	MOP
208	1	60 Hz	6.2 A	8.7 A	1.3 A	86.5 A	102.7 A	104.9 A	110 A
230	1	60 Hz	6.0 A	9.6 A	1.8 A	71.9 A	89.3 A	91.7 A	100 A
208	3	60 Hz	3.3 A	5.8 A	1.2 A	50.0 A	60.3 A	61.7 A	65 A
230	3	60 Hz	3.2 A	5.7 A	1.1 A	41.5 A	51.5 A	52.9 A	55 A
380	3	50 Hz	5.1 A	5.1 A	0.9 A	27.3 A	38.4 A	39.7 A	45 A
460	3	60 Hz	1.6 A	2.9 A	0.6 A	20.7 A	25.7 A	26.5 A	30 A
600	3	60 Hz	2.1 A	2.1 A	0.4 A	17.3 A	21.9 A	22.5 A	25 A

AJX-66/76CS

Volts	Phase	Freq	Pre-wash Motor	Wash Motor	Drive Motor	Wash Heater	Total Load	MCA	MOP
208	1	60 Hz	6.2 A	8.7 A	1.3 A	N/A	16.2 A	18.4 A	25 A
208	3	60 Hz	3.3 A	5.8 A	1.2 A	N/A	10.3 A	11.8 A	15 A
460	3	60 Hz	1.6 A	2.9 A	0.6 A	N/A	5.0 A	5.7 A	15 A

NOTICE Local codes may require more stringent protection than what is displayed here and on the data plate. Always verify with your electrical service contractor that your circuit protection is adequate and meets all applicable national and local codes. Numbers in this manual are for reference and may change without notice.

NOTICE On three-phase machines, imbalanced wild leg goes to L3. Also see the Motor Rotation section.

NOTICE Information below is for machine components only. If using a third-party external booster, consult booster manufacturer for booster information. For steam booster information, see Steam Line Connections section.



AJX-80/90CE

Volts	Phase	Freq	Pre-wash Motor	Wash Motor	Drive Motor	Wash Heater	Total Load	MCA	MOP
208	1	60 Hz	8.7 A	8.7 A	1.8 A	86.5 A	105.7 A	107.9 A	115 A
208	3	60 Hz	5.8 A	5.8 A	1.2 A	50.0 A	62.8 A	64.2 A	70 A
230	3	60 Hz	5.7 A	5.7 A	1.1 A	41.5 A	54.0 A	55.4 A	60 A
460	3	60 Hz	2.9 A	2.9 A	0.6 A	20.7 A	27.0 A	27.7 A	30 A

AJX-80/90CS

Volts	Phase	Freq	Pre-wash Motor	Wash Motor	Drive Motor	Wash Heater	Total Load	MCA	MOP
208	3	60 Hz	3.3 A	5.8 A	1.2 A	N/A	10.3 A	11.8 A	15 A
460	3	60 Hz	2.9 A	2.9 A	0.6 A	N/A	6.3 A	7.0 A	15 A

INSPECTION

Do not throw away the packaging if damage is evident!

Before installing the machine, check the packaging and machine for damage. Damaged packaging indicates possible damage to the product. If there is any type of damage to both the packaging and machine, **DO NOT THROW AWAY THE PACKAGING**. The machine has been inspected at the factory and is expected to arrive in new, undamaged condition. However, rough handling by carriers or others might result in damage to the machine while in transit. If this occurs, **DO NOT RETURN THE MACHINE TO THE MANUFACTURER**. Instead, contact the carrier and ask them to send a representative to the site to inspect the damage and complete an inspection report. You must contact the carrier and the dealer that sold you the machine within 48 hours of receiving the machine.

UNPACKING

The machine should be unpacked and removed from the pallet before installing. Remove the wooden lift beams and their associated brackets after the machine has been positioned. Open the front door and remove all materials from inside. Once unpacked, verify there are no missing parts. If a part is missing, contact the manufacturer immediately.

LEVELING

The machine is designed to operate while level. This is important to prevent any damage to the machine during operation and to ensure the best results. The machine comes equipped with adjustable bullet feet, which can be turned using a pair of pliers. Verify the machine is level from front-to-back and side-to-side before making any electrical or plumbing connections.

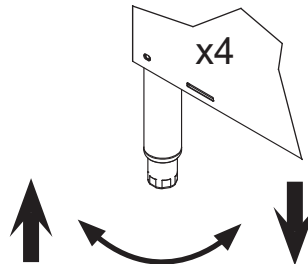

FACILITY HOT WATER HEATER

The manufacturer does **NOT** endorse "Tankless On-demand" water heaters for use with their machines. The manufacturer **DOES** endorse, and highly recommends, the standard "Tank" style water heaters, sized to properly handle the water heating requirements of the facility.

PLUMBING

*The plumber **MUST** flush the incoming water line!*

*A water hardness test **MUST** be performed.*

All plumbing connections must adhere to local, state, territorial, and national codes. The installing plumber is responsible for ensuring the incoming water lines are flushed of debris before connecting the machine. Chips and materials from cutting processes can become lodged in the solenoid valves and prevent them from opening or closing. Any valves that are found to be fouled or defective because of foreign matter left in the water line—and any subsequent water damage—are not the responsibility of the manufacturer.

If water hardness tests at greater than 3 GPG, install the Scaltrol Water Treatment system (see the Plumbing Options page) into the water line before the machine's incoming water connection point. If water hardness tests at 3 GPG or lower, install the water supply line directly to the machine's incoming water connection point. Iron in the water line can cause staining. A filter designed to remove iron from the water supply is highly recommended for supplies in excess of 0.1 ppm.



The manufacturer has an optional water pressure regulator to accommodate areas where water pressure fluctuates or is higher than the recommended pressure (see the Plumbing Options page). The machine uses a flow pressure of 15 PSI for the incoming water line. Do not confuse static pressure with flow pressure. Static pressure occurs when there is no flow and the valves are closed. Flow pressure occurs when water is running into the machine.

The water supply line must be 3/4" NPT minimum and must be able to provide water at the minimum temperature indicated on the machine data plate.

A shut-off valve (**not supplied**) should be installed to isolate the machine from the water system in the event service is required. An optional shock absorber (**not supplied**) should also be installed on the incoming water line (see the Plumbing Options page). This prevents water hammer (hydraulic shock) from causing damage to the equipment.

DRAIN LINE

The drain for the machine is a gravity-discharge drain. All piping to the machine drain must be a minimum 1 1/2" NPT and must not be reduced. There must be a minimum 1 1/2" air-gap between the machine drain line and the floor drain or sink. The floor drain or sink must be a minimum 3" NPT. If a grease trap is required by code, it should have a flow capacity of 30 GPM. AJX-44/54 machines have one drain connection point and AJX-66/76/80/90 machines have two (connected and drained into one facility floor drain or sink).



CAUTION! An air-gap is required between the drain line and floor drain or sink.

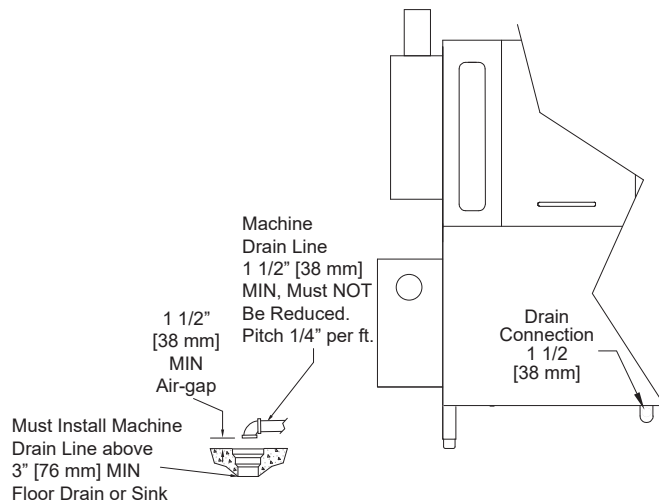

STEAM LINE CONNECTIONS



The steam machines come with lines to connect the source steam. Connect all steam lines to the machine as all applicable codes provide. See machine data plate for information concerning steam flow pressure.

Click [here](#) for the Steam Booster manual.

ELECTRICAL POWER CONNECTIONS



Disconnect electrical power at the breaker or disconnect switch and tagout in accordance with procedures and codes.

All electrical connections must be made in accordance with applicable portions of local, state, territorial, and national codes.

Refer to the data plate for machine operating requirements, machine voltage, total amperage, and serial number.

1. Locate main power terminal blocks (for the machine and for external booster option, if applicable) at the top of the machine.
2. Remove the top cover to access terminal blocks.
3. Route incoming power lines within conduit that will connect via fittings to the pre-punched holes in the back of the control box.
4. Install power and ground wires to lugs as indicated by the appropriate decals in the control box. Use copper conductors only. Use of an anti-oxidation agent is recommended on the power connections.

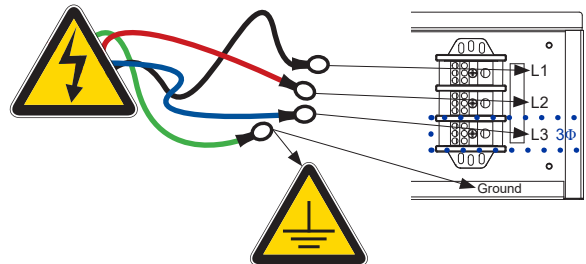

NOTICE
Imbalanced wild leg goes to L3.

5. Tighten all connections.
6. Verify the incoming voltage matches the voltage indicated on the decal next to the incoming power pre-punched hole.



NOTICE *The machine has a separate power connection for external boosters and the circuit protection requirements are different for each. Consult booster manufacturer for information.*

MOTOR ROTATION

On 3-Phase machines only, correct pump motor rotation must be verified before the machine is operated. Failure to do so can result in damage to the machine and components.

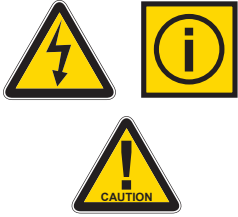

CAUTION! On 3-Phase machines only, correct pump motor rotation must be verified before operation!

1. Follow the Power Up section.

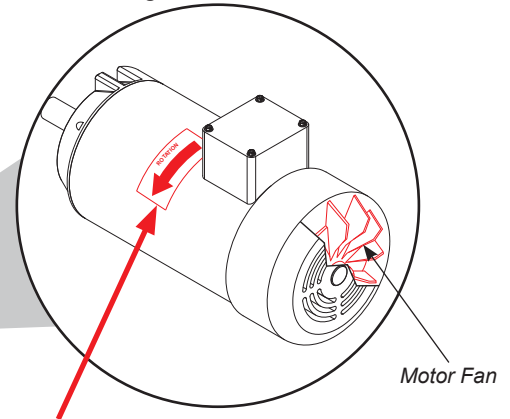
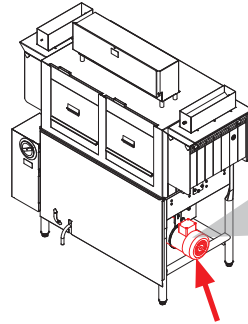

2. Locate the wash pump motor and identify the arrow decal which shows the correct motor rotation (if no decal is present, correct rotation is toward front of machine).
3. Flip AUTOMATIC/DELIME button to DELIME.
4. Flip ON/OFF button to ON.
5. Observe rotation of motor fan and quickly flip ON/OFF button to OFF.
6. If rotation is incorrect, disconnect electrical power and reverse the L1 and L2 connections at terminal block shown in the previous section.

VENTILATION

The machine should be located with an adequate exhaust hood or ventilation system with provisions for venting. This is essential to permit efficient removal of the condensation exhaust. Ensure the exhaust system is acceptable in accordance with applicable codes and standards.

NOTICE Any damage caused by steam and/or moisture due to improper ventilation is NOT covered under the warranty.

Machine ventilation requirements:

- **Load End: 200 CFM**
- **Unload End: 400 CFM**

The exhaust system must be sized to handle this volume for the machine to operate properly.

THERMOSTATS

The thermostats on this machine have been set at the factory and should only be adjusted by an authorized service agent.

TABLE LIMIT SWITCH OPTION

There are two Table Limit Switch options available. Click on the instruction icons below for install guides.

Striker Switch



Whisker Switch



CHEMICAL FEEDER EQUIPMENT



WARNING! Some chemicals used in dishwashing can cause chemical burns if they come in contact with skin. Wear protective gear when handling these chemicals. If any skin comes in contact with these chemicals, immediately follow the instructions provided with the chemicals for treatment.

This machine does not come with an integrated chemical supply/feeder system. For the machine to operate correctly, connect it to a third-party chemical dispenser (see Connection Points section) that meets the requirements of NSF Standard 29. Contact a chemical supplier about connecting a dispenser to the machine. Chemical dispensers must be set for the type and concentration of chemicals being used.

Detergent usage and water hardness are two factors that contribute greatly to how efficiently the machine will operate. Using the proper amount of detergent can be a source of substantial savings. A qualified water treatment specialist can explain what is needed to gain the maximum efficiency from detergent.

CONNECTION POINTS

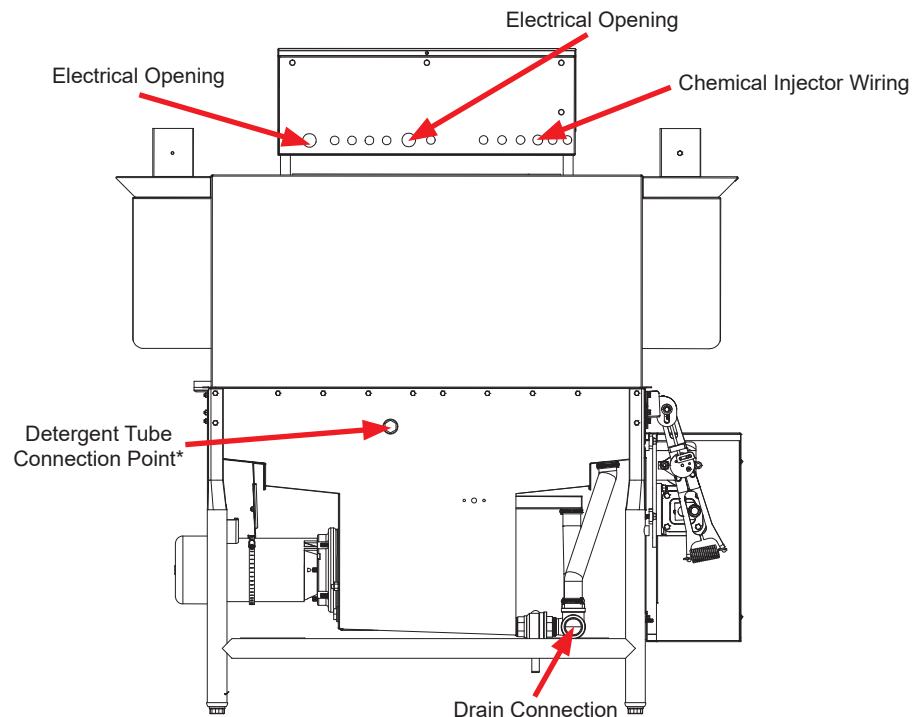
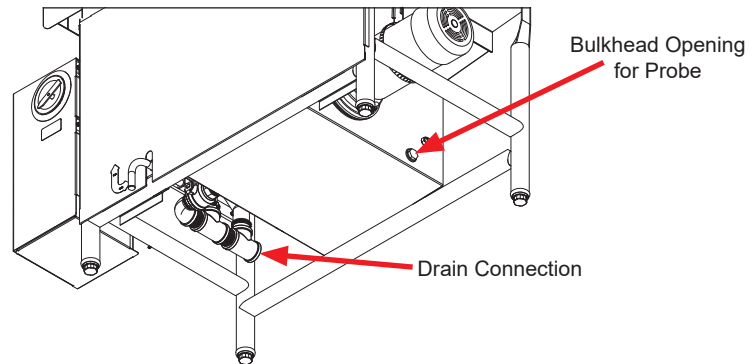

View of machine to the right is shown with plumbing removed for clarity.

*See next page for rinse-aid tube connection.

CONNECTION POINTS

Rinse-aid tube connection shown to the right.

Terminals marked "CVS" provide a voltage signal whenever the drive motor is operating.

Terminals marked "DET" provide a voltage signal whenever the wash motor is operating.

There is no dedicated connection for a rinse-aid dispenser on the machine.

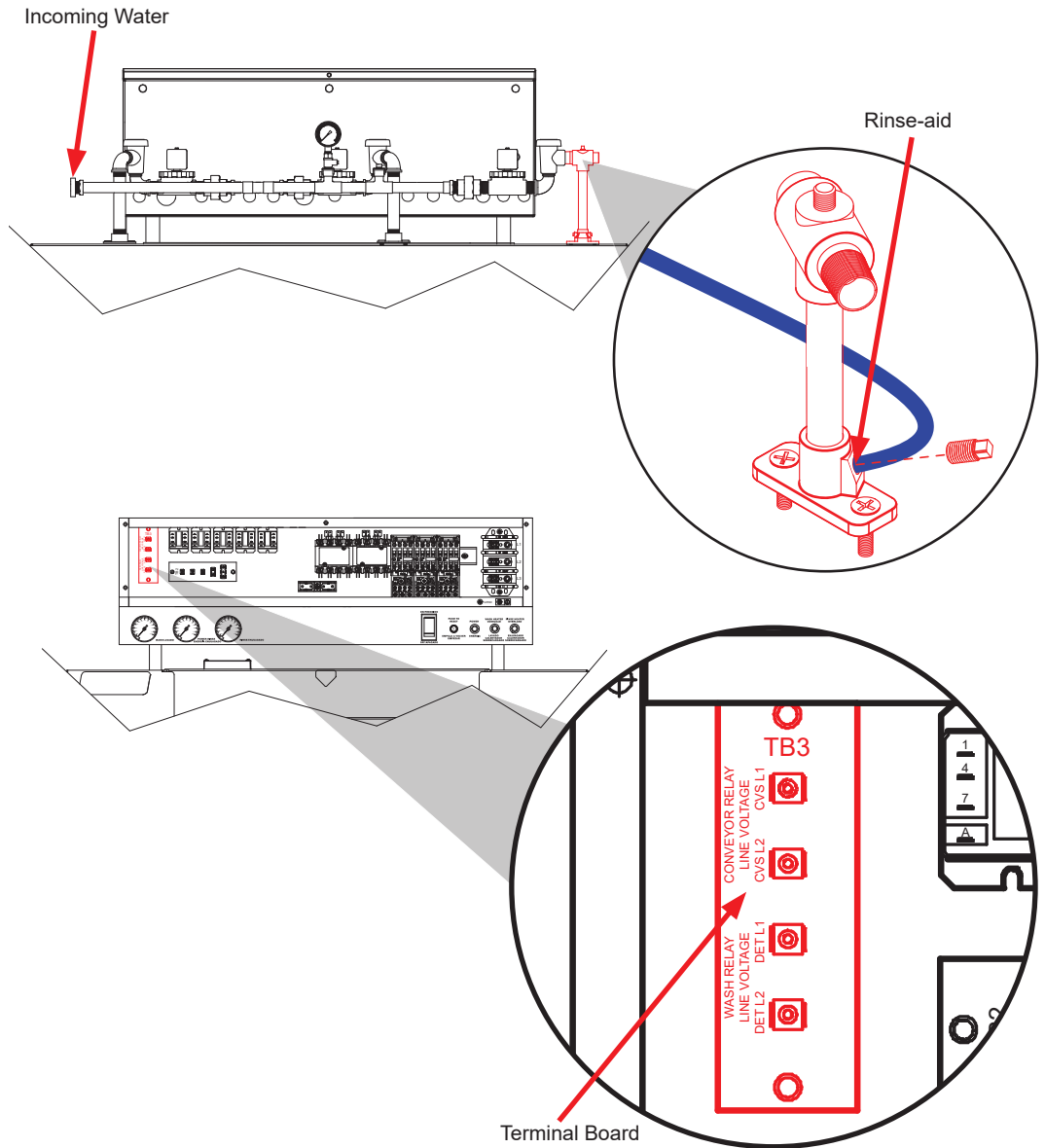

EXHAUST FAN TIMER



Click [here](#) for instructions on programming the exhaust fan timer. The instructions can also be accessed by navigating to them on our website.

Decals mark the curtain locations inside the machine, starting at the load end and ending at the unload end. The illustrations below (Left-to-Right machines shown, Right-to-Left are mirrored) indicate the curtain size to be placed on the curtain hooks provided. If any curtain components are missing, they **MUST** be obtained and installed before operation.

CE & CS

44/54

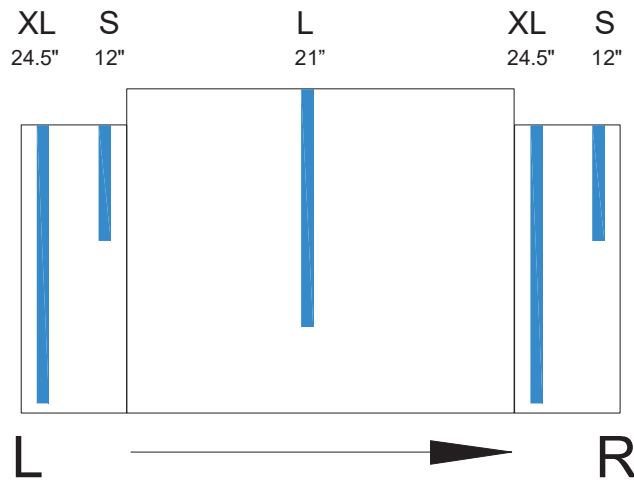

66/76/80/90

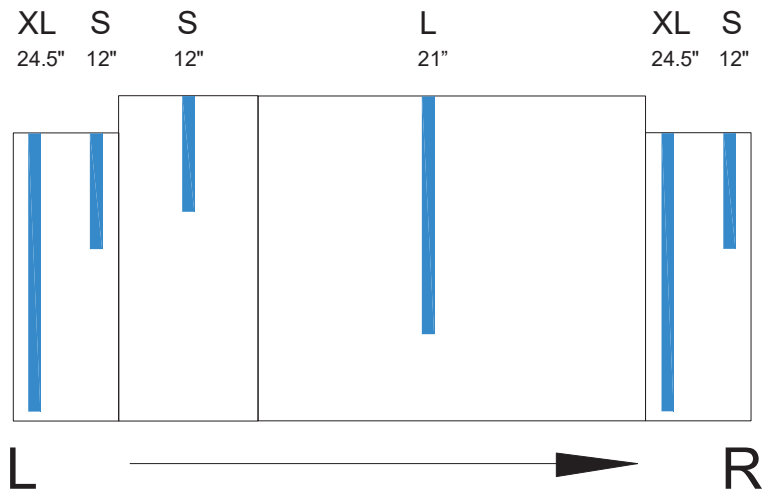

NOTICE See Curtains/Conveyor Switch page for part numbers.

PREPARATION Before operating the machine, verify the following:

1. Drain handle is turned to "CLOSE" position.

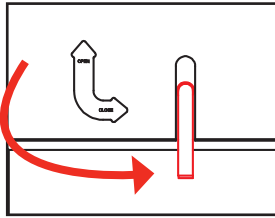

2. Strainers and pawl bar are installed and secure.

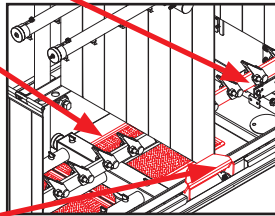

3. Actuator switches move with relative freedom and do not bind.

4. Curtains are installed correctly.

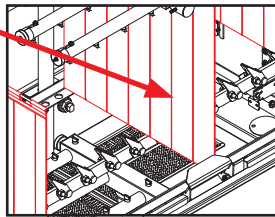

POWER UP 1. Turn power on at the service breaker.

2. Press ON button on front of the machine to fill the machine and heat the water.

For machines with pre-wash sections, ensure water is present in pre-wash section before operating.

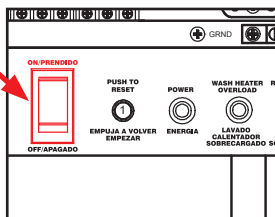

3. Allow wash tub to fill completely and wash water to reach operating temperature before continuing (an accurate rinse temperature will not display until machine is rinsing).

For steam models, ensure steam is connected and flowing to the machine.

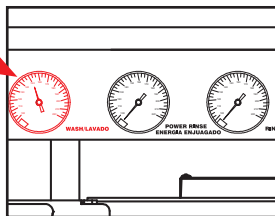

4. For Steam machines, ensure the steam service is connected and steam is flowing to the machine.

FIRST RACK

The first rack of ware placed in the machine will typically reduce the temperature of the wash tank, and might need to run through the machine again. This process might be necessary any time the machine has not been operated for an extended period of time, although this is dependent on the type of ware being used, its temperature, and the ambient temperature of the kitchen area. To ensure proper operation, always observe the temperatures of the wash and rinse when first starting the machine.

WARE PREPARATION

Proper preparation of ware is essential for the smooth, efficient operation of this machine.

Any ware placed in the machine should have all solid food waste and scraps removed. Ware should also be sprayed-down before entering the machine.

Place cups and glasses upside-down in racks so they do not hold water during the cycle. Presoak flatware in warm water to assist in removing food. Load plates and saucers in the same direction, with the food surface facing the unload end of the machine.

WASHING A RACK OF WARE

This machine is designed to wash ware that is placed in a rack. Materials should not be placed in the machine unless they are properly secured in a dish rack.

To start the cycle, gently push the rack into the machine on the load end. Once the wash actuator has moved sufficiently, the machine will automatically begin to convey the dish rack through the machine. The entire cycle is automatic.

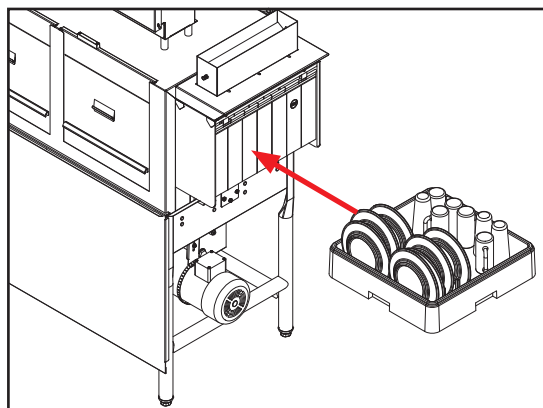

R-L machine shown.

OPERATIONAL INSPECTION

For machines with pre-wash sections, also inspect pre-wash strainer and wash arm nozzles.

Operators should periodically review the following items while the machine is operating. These items are important for operating the machine efficiently.

- Review wash and rinse temperatures and compare to the minimums on the data plate.
- Verify strainers are not becoming clogged. Keep these free of soil and debris for much better flow of water through the machine and to prevent re-deposit issues.
- Water pressure: The machine is designed to run at 15 PSI; if it is any lower there will not be enough rinse water to properly remove detergent from the ware.
- Wash and rinse arm nozzles should be free of debris. Open nozzles are essential to the operation of the machine.

SHUTDOWN To shut the machine down, press the OFF button on the front of the machine. To drain the machine, move the drain handle to the OPEN position. If the machine is equipped with a booster, shut it down according to its manufacturer's instructions.

CLEANING Clean the machine at least once every 24 hours or at the end of the day. Cleaning removes soil and debris that might become trapped in nozzles or deposited onto ware.

1. Remove all strainers and use a hand-scraper to scrape foodsoil into trash.

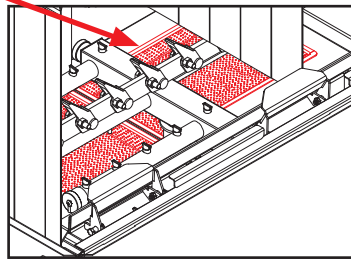

For machines with pre-wash sections, also remove and clean the pre-wash strainer.

2. Remove float switch cover and clean it and strainers with the pre-rinse hose.

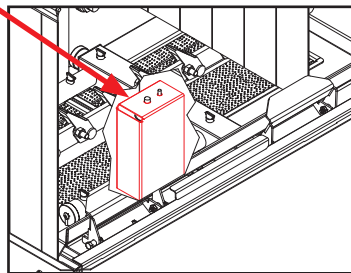

3. Rinse float switch off and rinse the tank out. Inspect tank for debris.

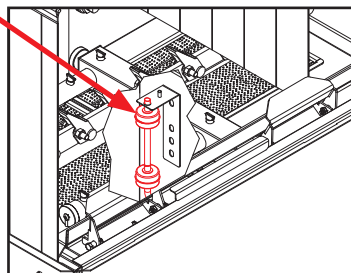

4. Remove curtains, scrub with mild detergent and brush, and allow to air-dry.

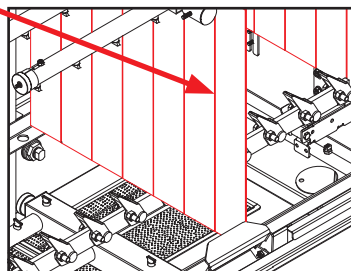

For machines with pre-wash sections, also remove and clean the pre-wash curtains.

CLEANING

5. As needed, clean the wash and rinse arms:
 - a. Remove wash arm manifolds.

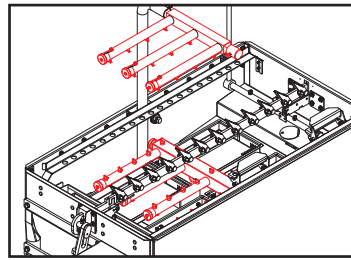

For machines with pre-wash sections, also remove and clean the pre-wash arm.

- b. Remove end-caps from arms and manifolds.

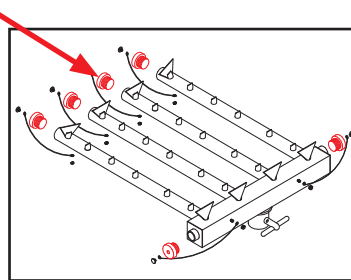

- c. Clean nozzles with a brush. Also clean rinse assembly nozzles.

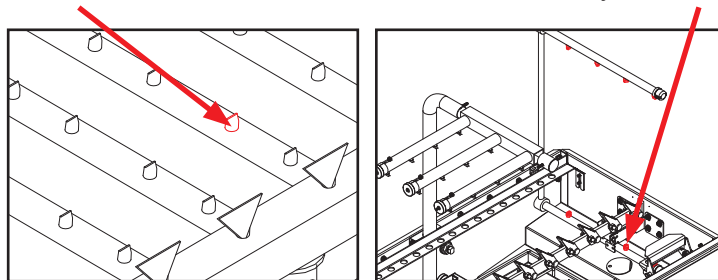

- d. Use a small wire or toothpick to remove remaining debris or lime deposits from nozzles.
 - e. Flush arms with water.

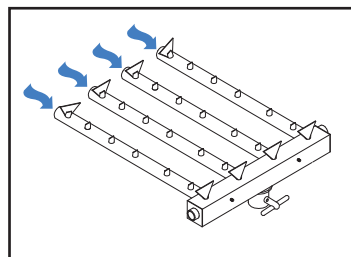

- f. Replace end-caps and ensure they have been tightened.
 - g. Replace wash arm manifolds.

Do NOT clean the machine with any type of metallic scrubbing sponge!

The outside of the machine should be cleaned with a standard countertop or general cleaner. Do not attempt to clean inside any compartments, boxes, or chambers that are secured with a cover. These normally contain live electrical components.

DELIMING

1. Disconnect/turn off chemical feeder equipment.
2. Turn the machine on.

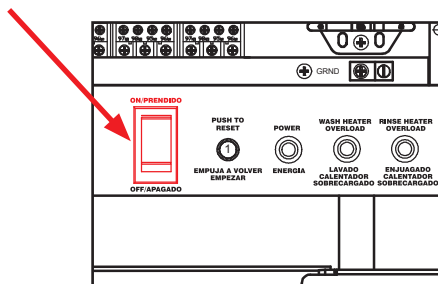

3. Add deliming solution according to chemical supplier's instructions.
4. Close door.
5. Flip AUTOMATIC/DELIME switch to DELIME.
6. Run the machine period of time recommended by chemical supplier.
7. Wait five minutes, then inspect inside of the machine. If the machine is not delimed, run again.
8. Flip AUTOMATIC/DELIME switch to AUTOMATIC.

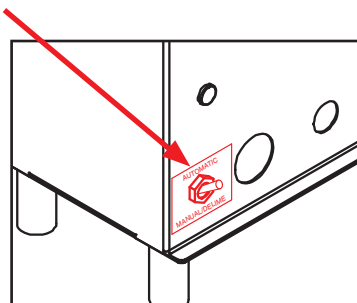

9. Run an empty rack through the machine twice.
10. Drain and re-fill the machine.
11. Reconnect/turn on chemical feeder equipment.



CAUTION! *This equipment is not recommended for use with deionized water or other aggressive fluids. Use of deionized water or other aggressive fluids will result in corrosion and failure of materials and components. Use of deionized water or other aggressive fluids will void the manufacturer's warranty.*

PREVENTATIVE MAINTENANCE

The manufacturer highly recommends that any maintenance and repairs not specifically discussed in this manual be performed only by QUALIFIED SERVICE PERSONNEL. Performing maintenance on your machine may void your warranty, lead to larger problems, or even cause harm to the operator. So if you have a question or concern, do not hesitate to contact a QUALIFIED SERVICE AGENCY.

By following the operating and cleaning instructions in this manual, you should get the most efficient results from your machine. As a reminder, here are some steps to ensure the machine is being used the way it was designed to work:



1. Ensure water temperatures match those listed on the machine data plate. There can be a variety of reasons why the water temperature could be too low.
2. Ensure all strainers are clean and in place laying flat before operating the machine. When cleaning out strainers, do NOT beat them on waste cans. Wipe-out strainers with a rag and rinse under a faucet if necessary. Use a toothpick to dislodge any stubborn debris.
3. Ensure all wash and rinse arms are secure in the machine before operating.
4. Ensure drains are closed before operating.
5. Remove as much soil from dishes by hand as possible before loading into racks.
6. Do not overfill racks.
7. Ensure glasses are placed upside-down in the rack.
8. Ensure all chemicals being injected into machine have been verified at the correct concentrations.
9. Clean the machine every 24 hours or at the end of every workday per the instructions in this manual.
10. Follow all safety procedures, whether listed in this manual or put forth by local, state, or national codes/regulations.

TORQUE SETTINGS

When replacing components in the control box or heater box, refer to the table below for the torque specs:

ITEM	TORQUE SPEC
Relays	16 in/lbs
Heater Contactor	35 in/lbs
Heater Nuts	16 in/lbs
Terminal Block	50 in/lbs

**DRIVE GEAR
REDUCER
LUBRICATION**

The maintenance procedures detailed here are manufacturer’s instructions for the brand of gear reducer that is installed on the machines covered in this manual.

Ambient Temperature	-30 to 15°F	16 to 50°F	51 to 95°F	51 to 95°F	96 to 131°F	96 to 131°F
Final Stage Worm Speed*	up to 2000 FPM	up to 2000 FPM	up to 450 FPM	above 450 FPM	up to 450 FPM	above 450 FPM
ISO Viscosity Grade	220	460	680	460	680	460*
AGMA Lubricant No.	5S**	#7 Compounded***	#8 Compounded***	#7 Compounded***	8 S**	7S**

Mobil	SHC 630	600W Super Cylinder	Extra Hecla Super	600W Super Cylinder	SHC 636	SHC 634
American Lubricants	SHC-90W	AGMA #7 Gear Oil	AGMA #8 Gear Oil	AGMA #7 Gear Oil	N/A	N/A
Castrol	Tribol 800/220	Tribol 1105-7C	Tribol 1105-8C	Tribol 1105-7C	Tribol 800/680	Tribol 800/460
Chevron	Tegra 220	Cylinder Oil W460	Cylinder Oil W680	Cylinder Oil W460	Tegra 680	Tegra 460
Conoco	Syncon R & O 220	Inca Oil 460	Inca Oil 680	Inca Oil 460	N/A	Syncon R & O 460
Exxon (Esso)	Teresstic SHP 220	Spartan EP 460	Spartan EP 680	Spartan EP 460	Teresstic SHP 680	Teresstic SHP 460
Fiske Brothers	SPO-MG	SPO-277	SPO-288	SPO-277	N/A	N/A
Shell	Omala RL 220	Valvata J 460	Valvata J 680	Valvata J 460	Omala RL 680	Omala RL 460
Texaco	Pinnacle 220	Vanguard 460	Vanguard 680	Vanguard 460	Pinnacle 680	Pinnacle 460

*The sliding velocity in feet per minute (FPM) for standard ratios is determined by multiplying the speed of the worm in RPM by the factor from the following table. For selecting the proper lubricant, use the speed of the worm in the final stage (input RPM divided by the first stage ratio).

**Synthetic oil.

***3% to 10% fatty or synthetic oils or mild EP additives.

Lubricant selections are provided by the lubricant manufacturer based on AGMA recommended viscosity grades.

Viscosity grades are based on Lubrication Standard ANSI/AGMA 9005-D94.

Nominal Ratio

Size	5	7.5	10	15	20	25	30	40	50	60	80	100
920	0.347	0.263	0.225	0.216	0.202	0.191	0.215	0.200	0.188	0.182	0.164	0.161

Factory filling - Speed reducers are filled with oil at the factory to the proper level for the standard mounting position it will be found on the machine. The oil level should be checked and adjusted (if necessary) before operation, using the oil level plug provided and while the machine is oriented in its operating position.

Ambient temperature - If the operating ambient temperature is other than 51–95 °F, refer to the lubrication chart and refill the machine with the correct grade based on actual ambient temperature and operating speed. See “Oil changing” below for additional information.

Oil changing - When changing the oil for any reason, it should be remembered that oils of various types might not be compatible. Therefore, when changing to a different oil, it is recommended that the housing be completely drained and thoroughly flushed with a light flushing oil before refilling with the appropriate lubricant. The oil level should be rechecked

DRIVE GEAR REDUCER LUBRICATION

after a short period of operation and adjusted, if necessary. When changing double-reduction models, each housing should be drained and filled independently, even though there could be a common level.

Initial oil change - The new oil in a speed reducer should be changed at the end of 250 hours of operation. This is equivalent to 30 days of operation for eight hours per day; 15 days of operation for 16 hours per day, or 10 days of operation for 24 hours per day.

Subsequent oil changes - Under normal conditions, after the initial oil change, the oil should be changed after every 2500 hours of operation, or every six months, whichever comes first. Under severe conditions (rapid temperature changes, moist, dirty, or corrosive environment) it could be necessary to change the oil at intervals of one to three months. Periodic examination of oil samples taken from the machine will help establish the appropriate interval.

Synthetic oils - Synthetic lubricants can be advantageous over mineral oils in that they generally are more stable, have a much longer life, and operate over a wider temperature range. These oils are appropriate for any application but are especially useful when machines are subjected to low start-up temperatures or high operating temperatures. However, continuous operation above 225 °F may cause damage to seals or other components. It is recommended that the initial oil be changed or filtered after the first 1500 hours of operation to remove metal particles that accumulate during break-in. Subsequent oil changes should be made after 5000 hours operation if machines are operating in a clean environment. This can be extended to 10,000 hours if using new reformulated Mobil SHC lubricants (orange in color) and the lubricant remains free of contamination over this period. See comments under "Subsequent oil changes" for discussion of severe ambient conditions.

Long-term storage or infrequent operation - If a speed reducer is to stand idle for an extended period of time, either before installation or during use, it is recommended that the machine be filled completely with oil to protect interior parts from rust and corrosion due to internal condensation. Be sure to drain the oil to the proper level before placing the speed reducer in service.

Grease fittings - Some machines are equipped with grease fittings to lubricate bearings not adequately lubricated by the oil splash. These fittings must be lubricated every three to six months depending on operating conditions. Bearing greases must be compatible with the type of gear lubricant being used (e.g. mineral, synthetic, food grade, etc.). For mineral oils, use a high-quality lithium base NLGOI #2 bearing grease. For synthetic oils, use a synthetic bearing grease such as Mobil Synthetic Universal grease, Mobilith SHC 100 or a suitable equivalent. For food-grade lubricants, use Chevron FM grease, NGLI 2, or equivalent.

Low input speeds (under 1600 RPM) - When input speeds are less than 1600 RPM, grease fittings will be required to lubricate any bearings not partially covered by the normal oil level.

Oil temperature - Speed reducers in normal operation can generate temperatures up to 200 °F depending on the type of reducer and the severity of the application (loading, duration of service, ambient temperatures). Excessive oil temperatures could be the result of several factors including overloading, overfilling, underfilling, or inadequate cooling.



WARNING: Inspection, testing, and repair of electrical equipment should only be performed by a qualified service technician. Many of the tests require that the machine have power to it and live electrical components be exposed. **USE EXTREME CAUTION WHEN TESTING THE MACHINE.**

OBSERVATION	POSSIBLE CAUSE	REMEDY
Nothing on machine operates. The power switch is ON and the power indicator light is OFF.	<ol style="list-style-type: none"> 1. Machine is not wired correctly to incoming power source. 2. Machine circuit breaker is tripped. 3. Service breaker is tripped. 	<ol style="list-style-type: none"> 1. Have an electrician verify wiring. 2. Reset the circuit breaker. If it trips again, contact an electrician to verify the machine amp draw. 3. Reset the service breaker. If it trips again, contact an electrician to verify the machine amp draw.
Machine will not fill. The power switch is ON and the power indicator light is ON.	<ol style="list-style-type: none"> 1. No water supplied to machine. 2. Machine doors are not closed. 3. Incoming water solenoid valve damaged/faulty. 4. Tank floats faulty. 	<ol style="list-style-type: none"> 1. Verify water lines have been connected to the machine. 2. Close doors completely. 3. Verify the valve is operating. If not, replace. 4. Verify the wiring of the floats. Verify that no debris is jamming the floats. Replace if necessary.
Machine fills, but fill is weak.	<ol style="list-style-type: none"> 1. Low incoming water pressure. 2. Incoming water solenoid is clogged. 	<ol style="list-style-type: none"> 1. Verify incoming water pressure during fill is 15 PSI. 2. Verify debris is not trapped in valve. If so, remove debris.
Low wash tank temperature.	<ol style="list-style-type: none"> 1. Low incoming water temperature. 2. Heater not energizing. 3. Low incoming voltage. 	<ol style="list-style-type: none"> 1. Verify the incoming water temperature matches the data plate. 2. Verify the wash tank heater is operating. If not, replace. 3. Have an electrician verify incoming power is the same as indicated on the data plate.
Low wash arm pressure, poor spray pattern.	<ol style="list-style-type: none"> 1. Clogged wash arm nozzles. 2. Clogged wash tank or wash pump strainers. 3. Worn wash pump impeller. 	<ol style="list-style-type: none"> 1. Verify nozzles are not clogged with debris. If so, remove debris. 2. Clean out strainers if necessary. 3. Verify status of impeller and replace if necessary.
Inadequate rinse.	<ol style="list-style-type: none"> 1. Low incoming water pressure. 2. Incoming water solenoid is clogged. 	<ol style="list-style-type: none"> 1. Verify incoming water pressure during fill is 15 PSI. 2. Verify debris is not trapped in valve. If so, remove debris.



WARNING: Inspection, testing, and repair of electrical equipment should only be performed by a qualified service technician. Many of the tests require that the machine have power to it and live electrical components be exposed. **USE EXTREME CAUTION WHEN TESTING THE MACHINE.**

OBSERVATION	POSSIBLE CAUSE	REMEDY
Pawl bar does not move.	<ol style="list-style-type: none"> Failed or broken overload spring. No power to the drive motor or failed drive motor. Pawl bar not properly installed. 	<ol style="list-style-type: none"> Replace spring if necessary. Verify power and wiring connections to the motor. If necessary, replace the motor. Verify the pawl bar is installed correctly.
Racks go through the machine, but results are poor.	<ol style="list-style-type: none"> Incorrect quantity of detergent for the water volume. Clogged strainers/scrap basket. Ware not being properly pre-scraped. Wash or rinse arms missing end-caps. Low tank heat. Inadequate rinse. Incorrect voltage coming to the machine. Wash pump cavitation due to low water level. 	<ol style="list-style-type: none"> Adjust detergent to appropriate level. Clean out strainers and scrap basket. Review Ware Preparation section. Verify and replace as required. See previous page. See previous page. Verify the voltage matches that on the machine data plate. Verify the drains are shut and the water level is correct.
Spotting of silverware, glasses, and dishes.	<ol style="list-style-type: none"> Incorrect final rinse temperature. Clogged wash and/or rinse nozzles and arms. Excessively hard water. Loss of water pressure due to clogged/obstructed wash pump. Ware not being properly pre-scraped. Incorrect detergent/chemical concentrations. 	<ol style="list-style-type: none"> Verify the rinse water temperature matches the data plate. Remove the arms and verify they and their nozzles are free of debris. Install a water softener. Turn the power off to the machine at the source. Drain the wash tank of water and verify the pump intake is free of debris. Review the Ware Preparation section. Verify the detergent/chemical concentrations are correct for the associated water volume.

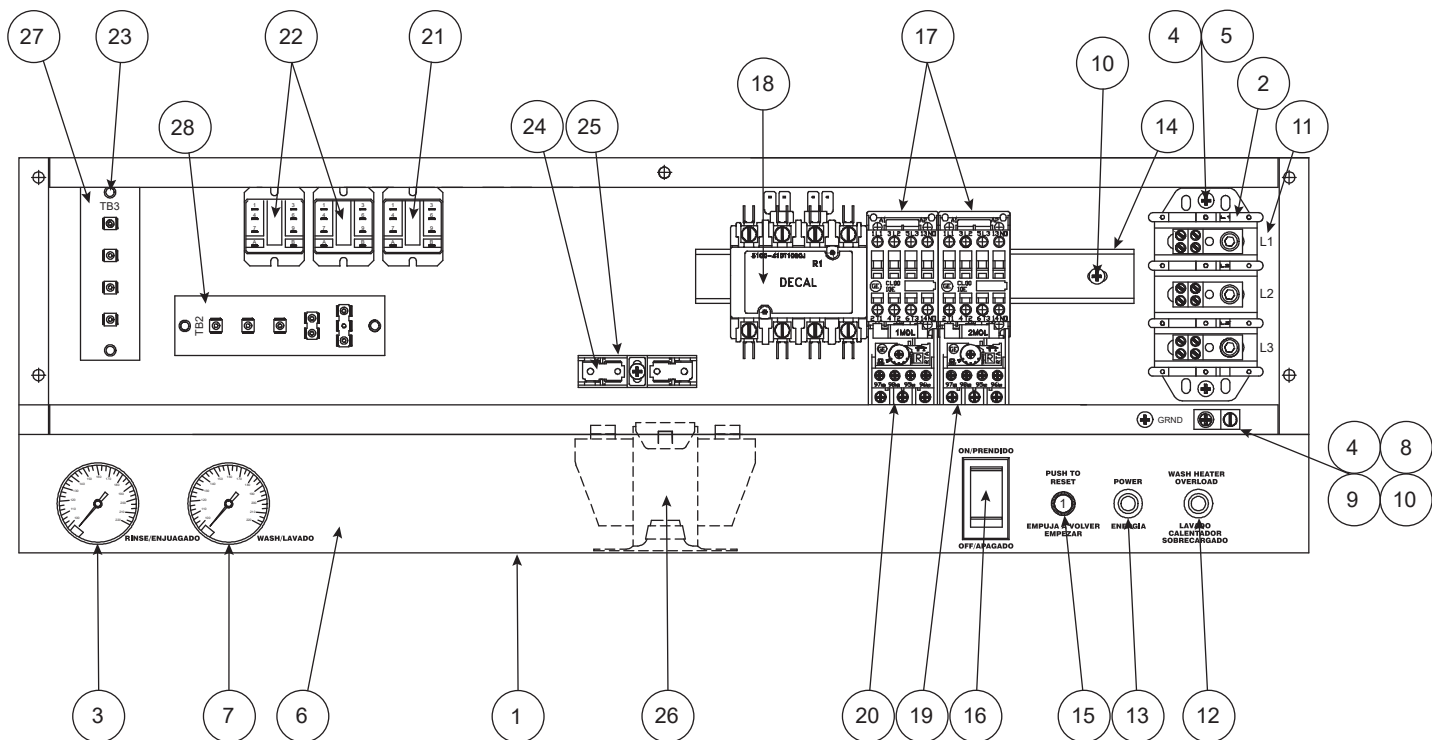

ITEM	QTY	DESCRIPTION	PART NUMBER
1	1	Electrical Box	05700-041-88-43
2	1	Terminal Block	05940-011-48-27
3	1	Rinse Thermometer, 96" Lead	06685-111-68-48
	1	Rinse Decal, 180 °F	09905-002-97-62
4	6	Star Washer, External Tooth, 10-24	05311-273-02-00
5	6	Screw, 10-32 x 3/4" Long Phillips Trusshead	05305-011-62-17
6	1	Decal, Gauge	09905-021-72-29
7	1	Wash, Thermometer, 48" Lead	06685-111-68-49
	1	Wash Decal, 160 °F	09905-003-00-69
8	1	Wire Lug, 2 AWG to 14 AWG	05940-200-76-00
9	1	Decal, Ground	09905-011-86-86
10	2	Screw, 10-32 x 1/2" Long Phillips Trusshead	05305-011-39-36
11	1	Decal, L1, L2, L3	09905-101-12-66
12	1	Light, Amber (CE Only)	05945-111-44-44
13	1	Light, Red	05945-111-44-45
14	1	Din Rail	05700-021-72-75

ITEM	QTY	DESCRIPTION	PART NUMBER
16	1	Switch, ON/FILL - OFF/DRAIN	05930-301-46-00
17	2	Motor Contactor	05945-111-68-38
18	1	Heater Contactor (CE Only)	05945-002-24-70
19	1	Overload	See Motor Overloads page.
20	1	Overload	See Motor Overloads page.
21	1	Control Relay	05945-111-35-19
22	2	Control Relay	05945-111-72-51
23	10	Screw, 6-32 x 3/8" Long Round Phillipshead	05305-002-25-91
24	1	Fuse (460 V Only)	05920-011-72-88
25	1	Fuse Holder (460 V Only)	05920-011-72-89
26	1	Transformer	05950-011-68-35
27	4	Locknut, 10-24 with Nylon Insert	05310-373-01-00
28	1	Terminal Board	05940-002-78-97
29	1	Terminal Board	05940-021-89-41

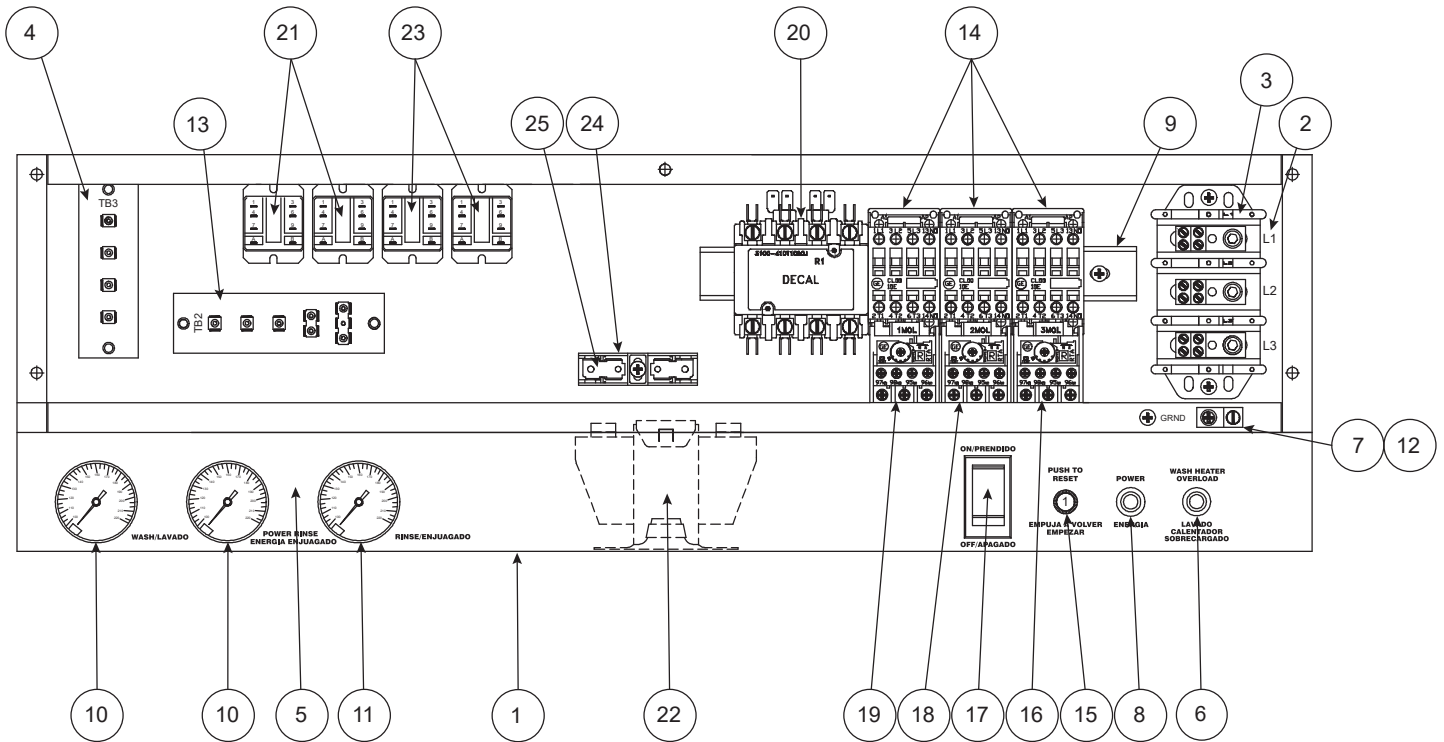

ITEM	QTY	DESCRIPTION	PART NUMBER
1	1	Electrical Box	05700-041-88-50
2	1	Decal, L1, L2, L3	09905-101-12-66
3	1	Terminal Block	05940-011-48-27
4	1	Terminal Board	05940-021-89-41
5	1	Decal, Gauge	09905-021-72-30
6	1	Light, Amber (CE Only)	05945-111-44-44
7	1	Wire Lug, 2 AWG to 14 AWG	05940-200-76-00
8	1	Light, Red	05945-111-44-45
9	1	Din Rail	05700-021-72-75
10	2	Rinse Thermometer, 96" Lead Rinse Decal, 180 °F	06685-111-68-48 09905-002-97-62
11	1	Wash, Thermometer, 48" Lead Wash Decal, 160 °F	06685-111-68-49 09905-003-00-69
12	1	Decal, Ground	09905-011-86-86

ITEM	QTY	DESCRIPTION	PART NUMBER
13	1	Terminal Board	05940-002-78-97
14	3	Motor Contactor	05945-111-68-38
15	1	Circuit Breaker (208-230 Volt, 60 Hz Models Only)	05925-011-68-34
16	1	Overload	See Motor Overloads page.
17	1	Switch, ON/FILL - OFF/DRAIN	05930-301-46-00
18	1	Overload	See Motor Overloads page.
19	1	Overload	See Motor Overloads page.
20	1	Heater Contactor (CE Only)	05700-002-24-70
21	2	Control Relay	05945-111-72-51
22	1	Transformer	05950-011-68-35
23	2	Control Relay	05945-111-35-19
24	1	Fuse Holder (460 V Only)	05920-011-72-89
25	1	Fuse (460 V Only)	05920-011-72-88

AJX-44/54

VOLTS	Hz	PHASE	DRIVE MOTOR	PRE-WASH MOTOR	WASH MOTOR
208	50	3	05945-011-84-59	N/A	05945-111-68-40
220	50	3	05945-011-84-59	N/A	05945-111-68-40
230	50	3	05945-011-84-59	N/A	05945-111-68-40
380	50	3	05945-002-71-09	N/A	05945-111-68-40
415	50	3	05945-111-69-12	N/A	05945-111-81-33
440	50	3	05945-111-69-12	N/A	05945-111-81-33
208	60	1	N/A	N/A	N/A
230	60	1	N/A	N/A	N/A
200	60	3	05945-002-66-00	N/A	05945-002-65-99
208	60	3	05945-111-68-39	N/A	05945-111-68-40
230	60	3	05945-111-68-39	N/A	05945-111-68-40
380	60	3	05945-111-69-12	N/A	05945-111-81-33
460	60	3	05945-111-68-39	N/A	05945-111-68-40
600	60	3	05945-111-69-12	N/A	05945-111-81-33

AJX-66/76

VOLTS	Hz	PHASE	DRIVE MOTOR	PRE-WASH MOTOR	WASH MOTOR
208	50	3	05945-011-84-59	N/A	05945-111-68-40
220	50	3	05945-011-84-59	N/A	05945-111-68-40
230	50	3	05945-011-84-59	N/A	05945-111-68-40
380	50	3	05945-002-71-09	N/A	05945-111-68-40
415	50	3	05945-111-69-12	N/A	05945-111-81-33
440	50	3	05945-111-69-12	N/A	05945-111-81-33
208	60	1	N/A	N/A	N/A
230	60	1	N/A	N/A	N/A
200	60	3	05945-002-66-00	N/A	05945-002-65-99
208	60	3	05945-111-68-39	N/A	05945-111-68-40
230	60	3	05945-111-68-39	N/A	05945-111-68-40
380	60	3	05945-111-69-12	N/A	05945-111-81-33
460	60	3	05945-111-68-39	N/A	05945-111-68-40
600	60	3	05945-111-69-12	N/A	05945-111-81-33

AJX-80/90

VOLTS	Hz	PHASE	DRIVE MOTOR	PRE-WASH MOTOR	WASH MOTOR
208	50	3	05945-011-84-59	N/A	05945-111-68-40
220	50	3	05945-011-84-59	N/A	05945-111-68-40
230	50	3	05945-011-84-59	N/A	05945-111-68-40
380	50	3	05945-002-71-09	N/A	05945-111-68-40
415	50	3	05945-111-69-12	N/A	05945-111-81-33
440	50	3	05945-111-69-12	N/A	05945-111-81-33
208	60	1	N/A	N/A	N/A
230	60	1	N/A	N/A	N/A
200	60	3	05945-002-66-00	N/A	05945-002-65-99
208	60	3	05945-111-68-39	N/A	05945-111-68-40
230	60	3	05945-111-68-39	N/A	05945-111-68-40
380	60	3	05945-111-69-12	N/A	05945-111-81-33
460	60	3	05945-111-68-39	N/A	05945-111-68-40
600	60	3	05945-111-69-12	N/A	05945-111-81-33

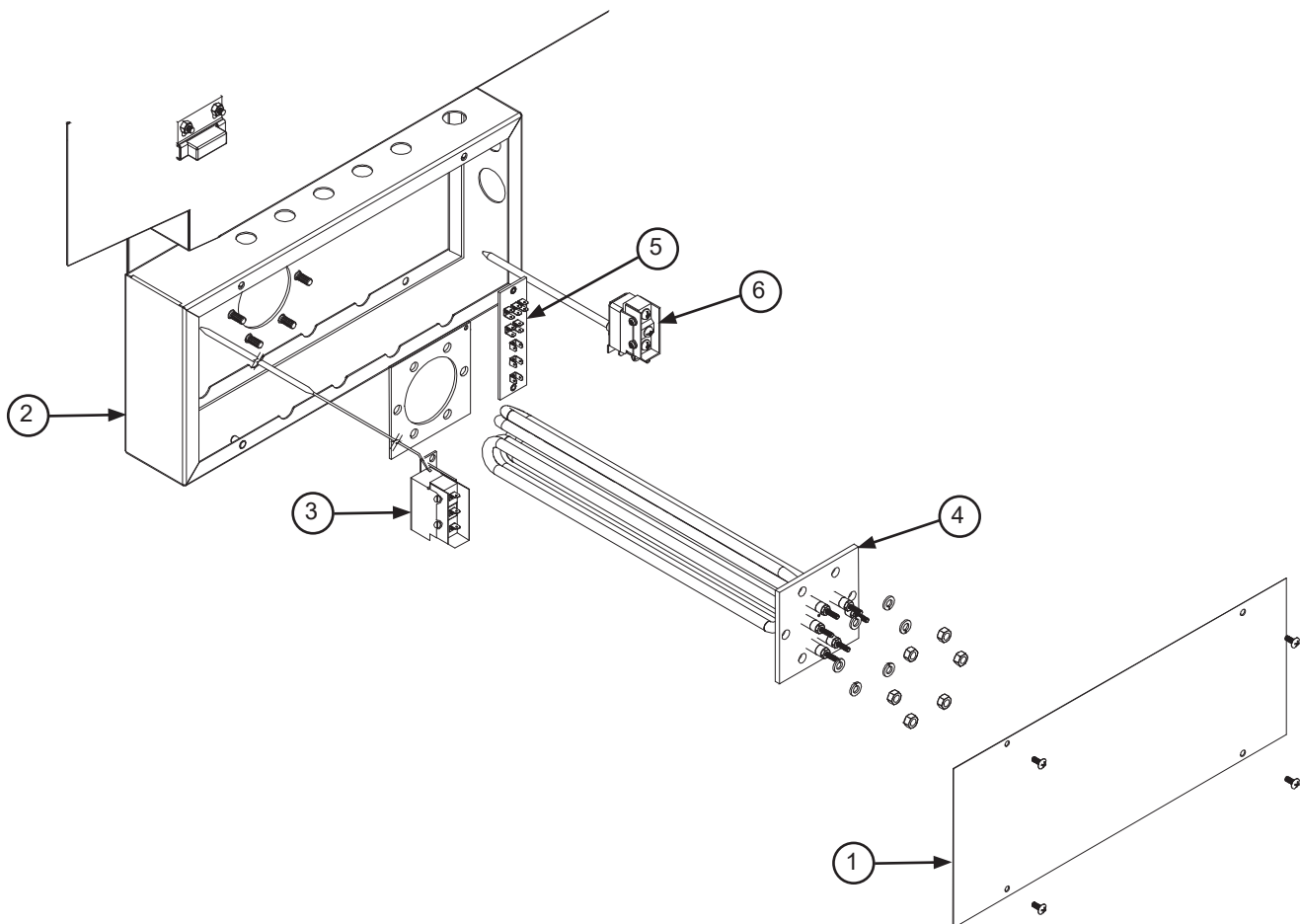

ITEM	QTY	DESCRIPTION	PART NUMBER
1	1	Heater Box Cover	05700-002-02-04
2	1	Heater Box	05700-002-98-38
3	1 1	Thermostat, High Limit Fitting, 1/4", Imperial Brass	05930-011-49-43 05310-924-02-05
4	1	Heater	See next page.
5	1	Terminal Board	05940-002-78-97
6	1 1	Kit, Wash Regulating Thermostat (CE Series) Kit, Wash Regulating Thermostat (CS Series)	06401-003-18-20 06401-003-18-21

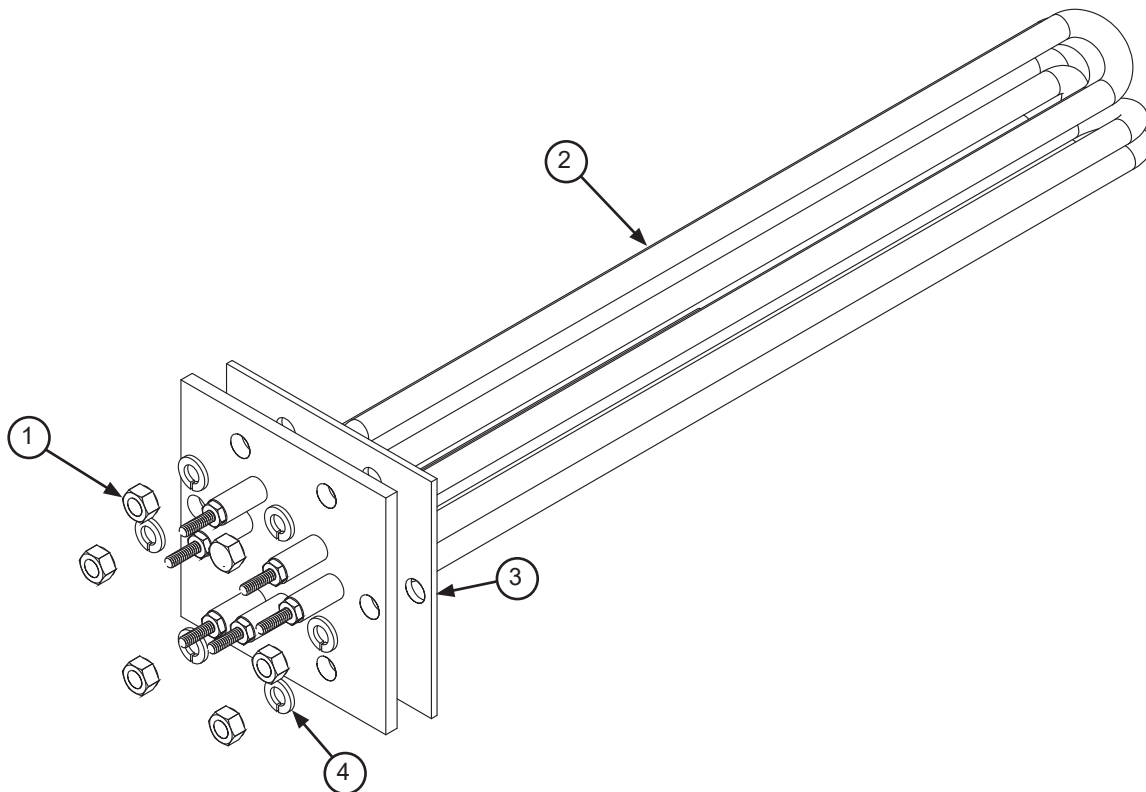

ITEM	QTY	DESCRIPTION	PART NUMBER
1	5	5/16-18 Hex Nut	05310-275-01-00
2	1	Heater	See table below.
3	1	Heater Gasket	05330-200-02-70
4	2	5/16" Lockwasher	05311-275-01-00

HEATERS

VOLTS	kW	PHASE	PART NUMBER
208	18	1	04540-121-79-30
230	18	1	04540-121-79-31
208	18	3	04540-121-79-30
230	18	3	04540-121-79-31
460	18	3	04540-121-79-32

*Steam models do not use electric heaters.

NOTICE When replacing a heater, it is **HIGHLY** recommended that the heater gasket be changed as well. Once installed, gaskets become compressed and are subjected to extreme temperature changes. Replacing the gasket when replacing the heater can prevent future leaks.

NOTICE The nuts used to secure the heater to the tub should be torqued to 16 in-lbs. After tightening, the unit should be allowed to heat-up and operate normally for approximately 30 minutes. Secure power to the machine and check the nuts once more to ensure that they are torqued to 16 in-lbs.

HEATER SYSTEM TROUBLESHOOTING

The wash tank heater system is electrically-connected in the circuit and is dependent upon the machine being properly filled with water and maintaining a safe water level. The system consists of two thermostats (mounted in the heater box behind the dress panel), a float switch (mounted in the wash tank), the heater relay (mounted in control box), and the heater which is activated by the thermostats.

Once the dishmachine has filled to the correct level, the heater should operate automatically. Should the tank heat be too high or too low or if there is no indication of temperatures at all, the following checks should be made by an authorized service agent or electrician:

Heater System Check

1. If the temperature is too high, adjust thermostat using instructions on the next page.
2. If temperature is too low, adjust thermostat as above, then:
3. Turn off power to machine by placing customer's circuit breaker in the "OFF" position. Turn off machine circuit breaker located on right side of control box.
4. Remove cover from control box on top of machine.
5. Make sure water temperature is below 140 °F (preferably about 130 °F).
6. Turn on both circuit breakers. Observe heater relay (R1) while the power switch is turned "ON" and "OFF." If relay contacts move in and out, the heater relay is operating correctly. Based on results, follow the appropriate section below (Relay Closes if contacts move in and out, Relay Does Not Close if contacts do not move in and out).

Relay Closes

1. Check power supply at incoming terminal board (L1, L2, L3). It should be the same voltage as indicated on the machine data plate.
2. Check power at connections on heater relay (R1). The voltage should agree with the voltage on the machine data plate. If not, check wires for breaks or bad connections.
3. Check power at terminals of heater, which should agree with the data plate. If not, check wires for breaks or bad connections.
4. Temperatures should rise as explained in Step 1 of the Relay Does Not Close section below, and amperage can be checked according to those instructions. Replace any defective elements.

Relay Does Not Close

1. There is an insulated movable bar on the relay across the top. With an insulated probe, depress this bar and observe the thermometer: the temperature should rise noticeably in a minute or two. If it moves slowly, the element is probably faulty. If it moves constantly higher at a good rate, the element should be good.

NOTICE *A check with an amp-probe at heater relay (R1) terminals should be made to verify the amp draw on each leg. This should be appropriate for the voltage and phase indicated on the data plate.*

HEATER PROTECTION AND AUTOMATIC FILL (FOR UNITS EQUIPPED WITH AUTOMATIC FILL)

This control is activated when the power switch is turned "ON." The primary function is to automatically energize the wash tank heating circuit. It will also cut-off the wash tank heating circuit should the water be accidentally drained from the machine with the power switch still "ON." The power switch should always be turned-off before draining the unit.

This water level control consists of two floats that operate when the power switch is turned "ON" and works in conjunction with the thermostats and heater relays.

When the power switch is turned "ON," water starts to enter the dishmachine. When it reaches the proper level, the normally-open contacts in the water level float switch close, activating the heating circuit for tank heat.

If the water level falls below the correct level while power is still on, the float switch will sense the lack of water and deactivate the heater.

THERMOSTATS

The thermostat range is from 140 °F to 240 °F with a maximum bulb-exposure temperature of 300 °F.

Calibration:

Wash Thermostat: Setpoint: 165 °F (Adjustable range)

High-Limit Thermostat: Fixed setpoint: 210 °F (Non-adjustable)

The high-limit thermostat is used to protect the heater element in the event of a run-away regulating thermostat or a dry-fire situation. It is set for 210 °F +0 °F or -10 °F with a fixed setpoint. This part is not adjustable.

The wash tank regulating thermostat will maintain the correct wash water temperature to meet regulatory requirements. These specify that the wash be no lower than 140 °F on chemical-sanitizing machines and no lower than 160° F on hot-water-sanitizing machines.

SHOCK ABSORBER (WATER ARRESTOR) OPTION

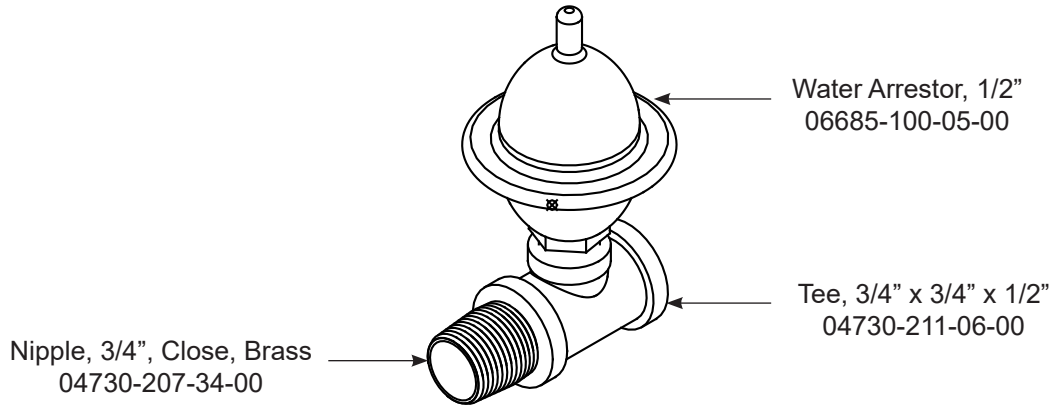

WATER TREATMENT OPTION

Scaltrol System
04730-003-05-76

Replacement Cartridge
(inspect at least every 6 months)
RSC-100

PRESSURE REGULATING VALVE OPTION (WITH SHOCK ABSORBER)

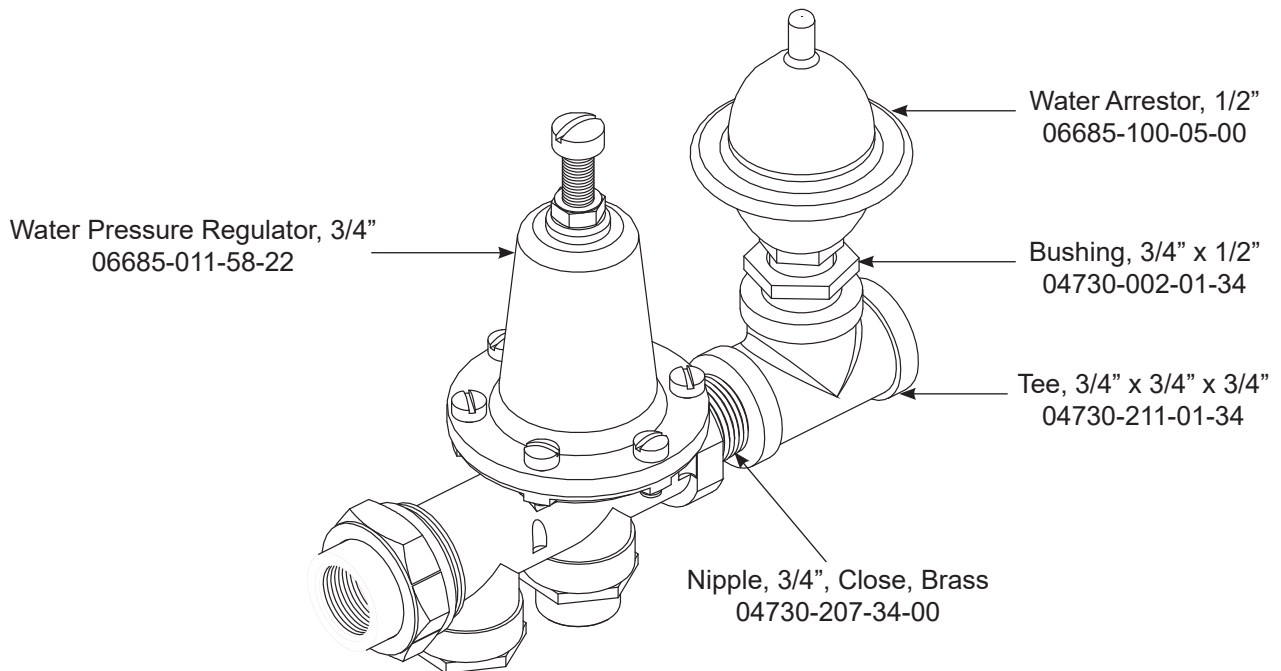

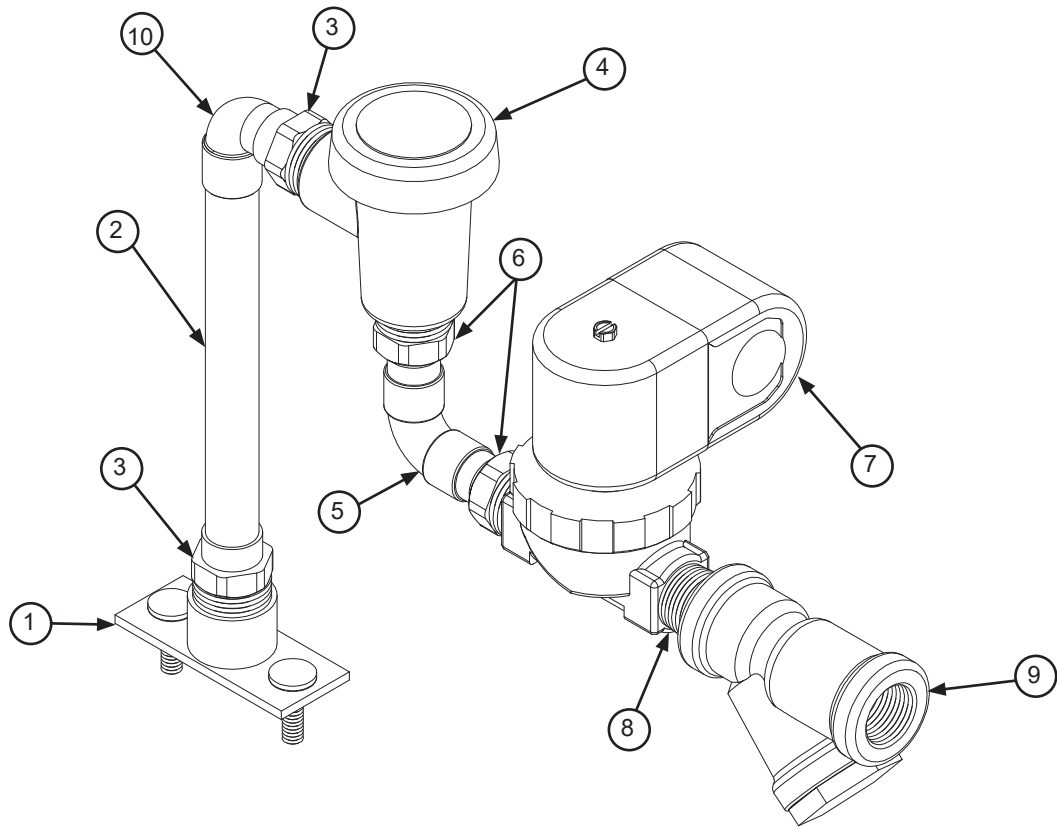

ITEM	QTY	DESCRIPTION	PART NUMBER
1	1	Fill Line Injector	05700-002-04-71
	1	Gasket, Fill Line Injector	05330-111-42-81
2	1	Tube, Copper, 1/2"	05700-002-04-93
3	2	Adapter, Male	04730-401-03-01
4	1	Vacuum Breaker	04820-003-06-13
5	1	Elbow, 1/2"	04730-406-01-01
6	2	Adapter, 1/2"	04730-011-59-53
7	1	Valve, Solenoid, 1/2", 110 V	04810-100-12-18
8	1	Nipple, 1/2", Close, Brass	04730-207-15-00
9	1	Y-strainer, 1/2"	04730-217-01-10
10	1	Elbow, 1/2"	04730-406-31-01

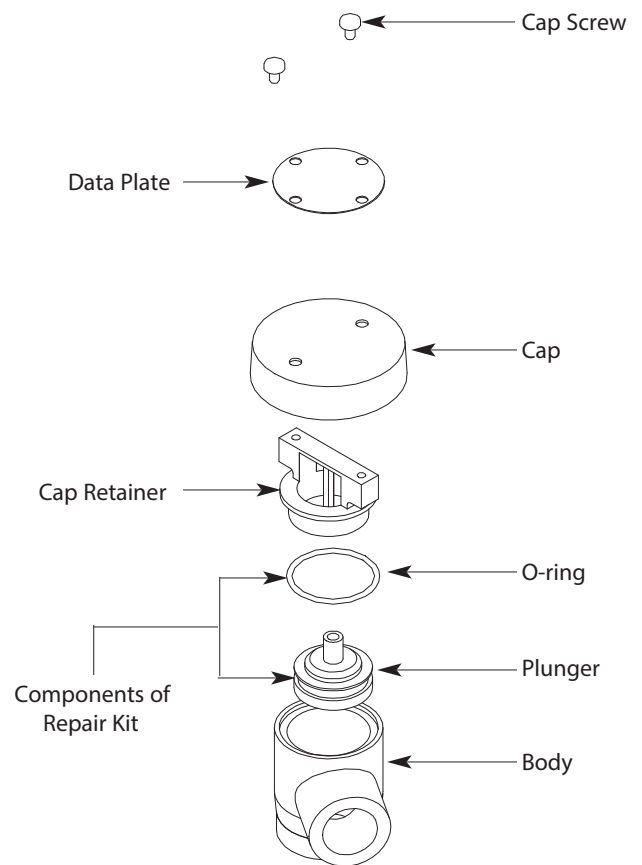
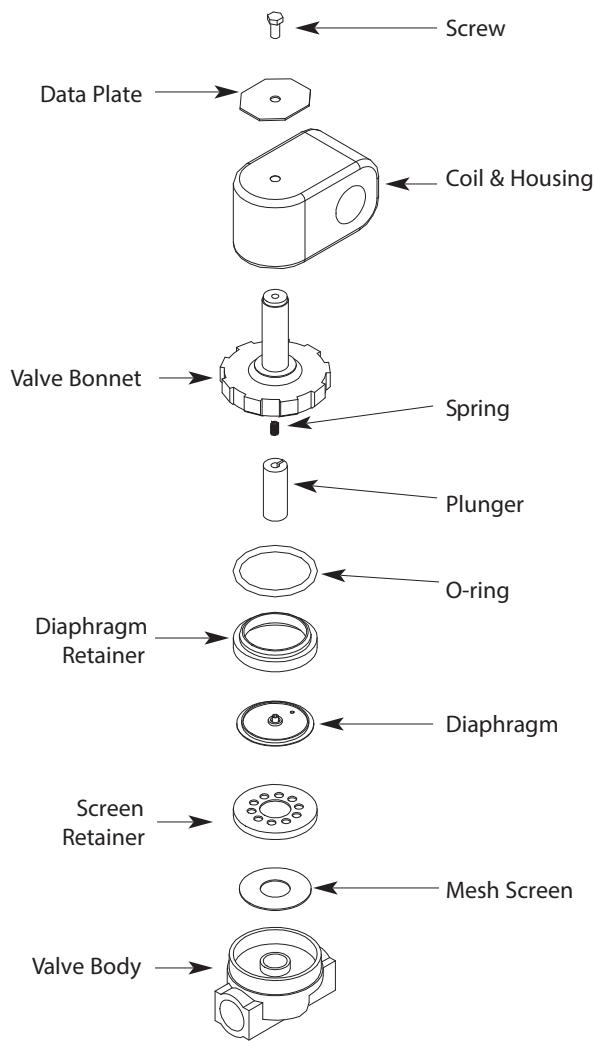

- Solenoid Valve Plunger Kit
Includes plunger and spring
06401-003-07-40
- Solenoid Valve Diaphragm Kit
Includes diaphragm and o-ring
06401-003-07-41
- Solenoid Valve 110 V Coil and Housing Kit
06401-003-07-43
- Complete Solenoid Valve
04810-100-12-18

- Vacuum Breaker Repair Kit
06401-003-06-23
- Complete Vacuum Breaker Assembly
04820-003-06-13

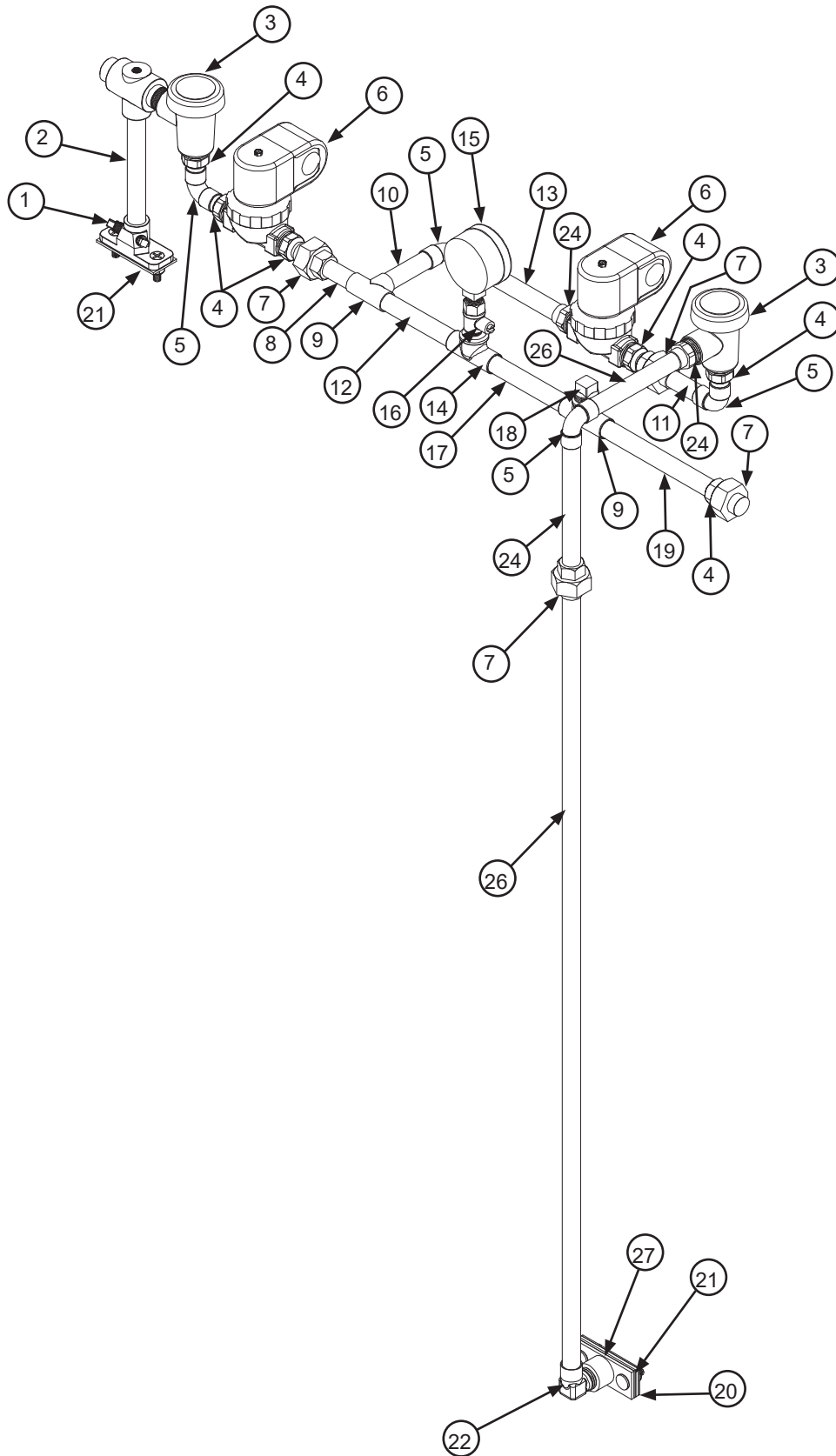

ITEM	QTY	DESCRIPTION	PART NUMBER
1	2	Plug, 1/8", Brass	04730-209-07-37
2	1 1	Rinse Injector Gasket, Rinse Injector	05700-002-03-42 05330-111-42-81
3	2	Vacuum Breaker, 1/2"	04820-003-06-13
4	6	Adapter, 1/2"	04730-011-59-53
5	3	Elbow, 1/2"	04730-406-01-01
6	2	Valve, Solenoid, 1/2"	04810-100-12-18
7	4	Union, 1/2"	04730-412-05-01
8	1	Tube, Copper, 1/2" x 2"	See note below.
9	1	Tee, Copper, 1/2"	04730-411-01-01
10	1	Tube, Copper, 1/2" x 3.06"	See note below.
11	1	Tube, Copper, 1/2" x 2.08"	See note below.
12	1	Tube, Copper, 1/2" x 4"	See note below.
13	1	Tube, Copper, 1/2" x 5.27"	See note below.
14	2	Tee, 1/2" x 1/2" x 1/4"	04730-411-25-01
15	1 1	Gauge, Pressure, 0-100 PSI Decal, 15-25 PSI	06685-111-88-34 09905-002-97-74
16	1	Valve, Ball, 1/4"	04810-011-72-67
17	1	Tube, Copper, 1/2" x 4.185"	See note below.
18	1	Plug, 1/4", Brass	04730-209-01-00
19	1	Tube, Copper, 1/2" x 5.92"	See note below.
20	1	Plate, Rinse Plumbing	05700-011-82-86
21	2	Gasket	05330-111-42-81
22	1	Elbow, 90-degree, 1/2"	04730-406-32-01
23	2	Adapter, Male	04730-401-03-01
24	1	Tube, Copper, 1/2" x 5.75"	See note below.
25	1	Tube, Copper, 1/2" x 4.75"	See note below.
26	1	Tube, Copper, 1/2" x 40"	See note below.
27	1	Plate, Deflector	05700-002-62-49

NOTICE Copper tubing should be purchased locally and cut to the length shown in the part description.

Complete Steam Coil Assembly
05700-002-11-78

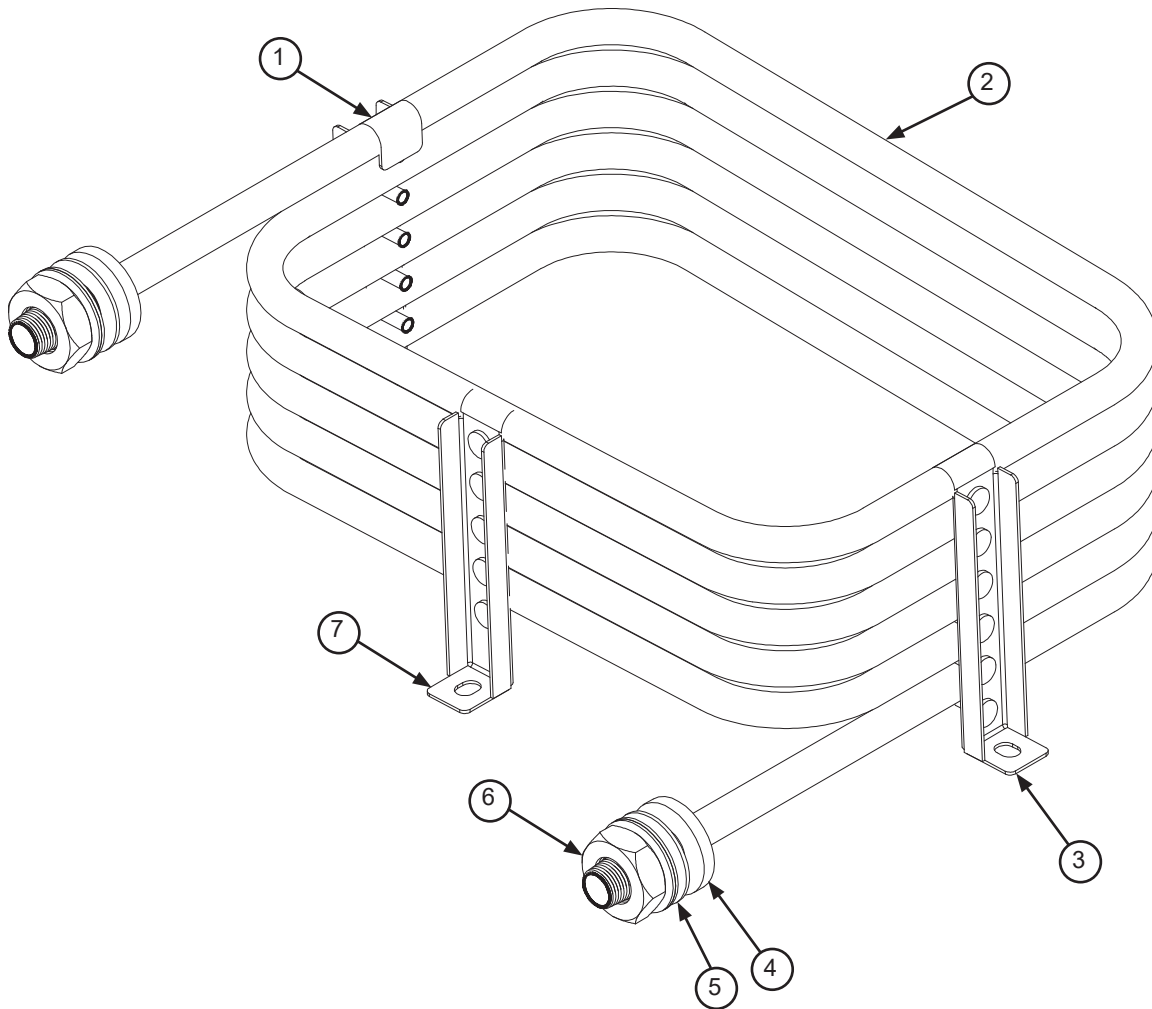

ITEM	QTY	DESCRIPTION	PART NUMBER
1	1	Stand "D"	05700-002-74-85
2	1	Steam Coil	05700-002-84-03
3	1	Stand "C"	05700-002-74-84
4	1	Coil Gasket	05700-001-17-86
5	1	Flat Washer	05700-001-17-87
6	1	Coil Nut	05310-011-17-85
7	1	Stand "B"	05700-002-74-83

NOTICE The Coil Gasket should be replaced any time the Steam Coil is replaced or removed for an extended period of time.

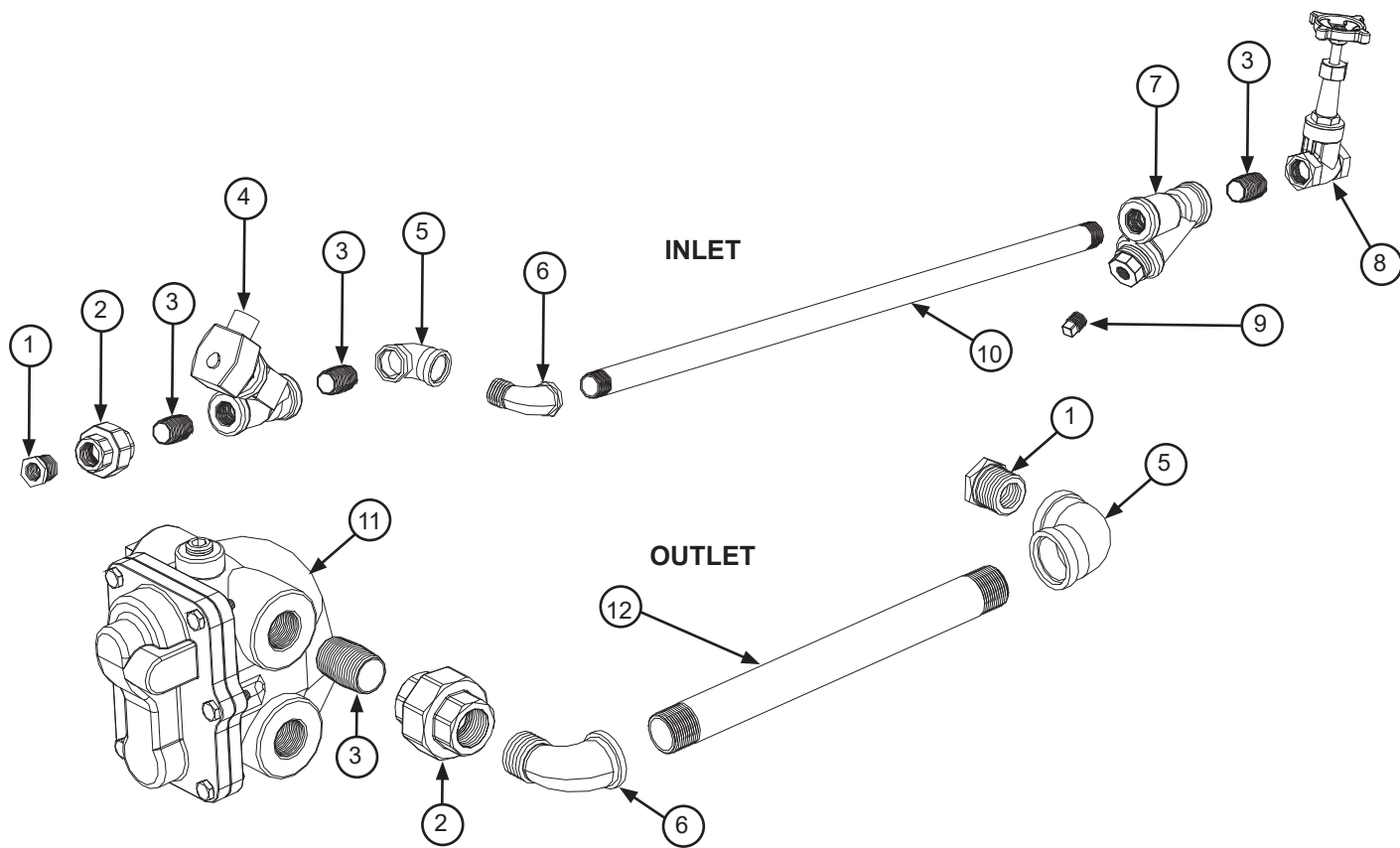

ITEM	QTY	DESCRIPTION	PART NUMBER
1	2	Reducer, 3/4" to 1/2", Black Iron	04730-911-02-34
2	2	Union, 3/4", Black Iron	04730-912-01-00
3	4	Nipple, Close, 3/4", Black Iron	04730-907-01-00
4	1	Valve, Steam Solenoid, 3/4", 120 V	04820-011-87-39
5	2	Elbow, 90-degree, 3/4", Black Iron	04730-906-10-34
6	2	Elbow, Street, 90-degree, 3/4", Black Iron	04730-011-87-37
7	1	Y-strainer, 3/4", Black Iron	04730-217-01-32
8	1	Valve, Gate, Steam, 3/4"	04820-100-19-00
9	1	Plug, 3/8", Black Iron	04730-909-02-34
10	1	Pipe, 3/4" x 32" Long, Black Iron	04730-002-21-27
11	1	Steam Trap, 3/4"	06680-500-02-77
12	1	Pipe, 3/4" x 10" Long, Black Iron	04730-907-06-34

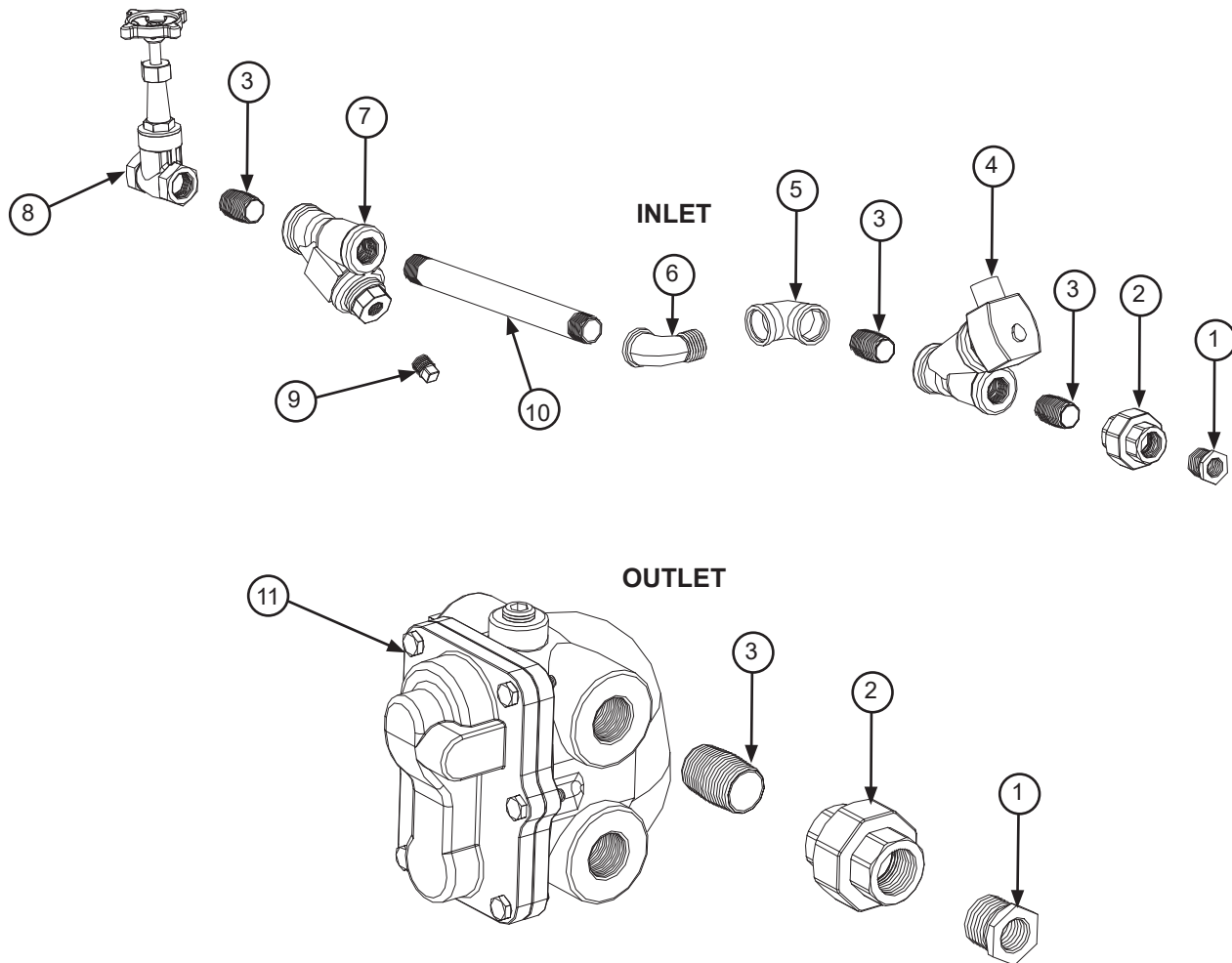

ITEM	QTY	DESCRIPTION	PART NUMBER
1	2	Reducer, 3/4" to 1/2", Black Iron	04730-911-02-34
2	2	Union, 3/4", Black Iron	04730-912-01-00
3	4	Nipple, Close, 3/4", Black Iron	04730-907-01-00
4	1	Valve, Steam Solenoid, 3/4", 120 V	04820-011-87-39
5	1	Elbow, 90-degree, 3/4", Black Iron	04730-906-10-34
6	1	Elbow, Street, 90-degree, 3/4", Black Iron	04730-011-87-37
7	1	Y-strainer, 3/4", Black Iron	04730-217-01-32
8	1	Valve, Gate, Steam, 3/4"	04820-100-19-00
9	1	Plug, 3/8", Black Iron	04730-909-02-34
10	1	Pipe, 3/4" x 32" Long, Black Iron	04730-002-21-27
11	1	Steam Trap, 3/4"	06680-500-02-77

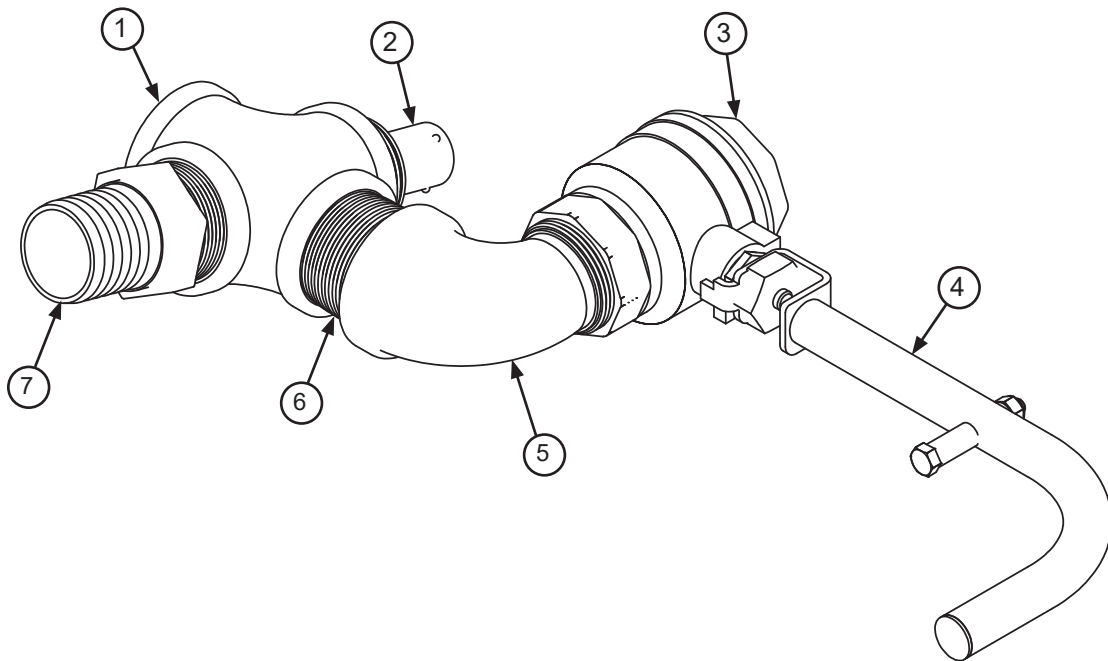

ITEM	QTY	DESCRIPTION	PART NUMBER
1	1	Cross Connector, 1 1/2"	04710-004-43-65
2	1	Nipple, Rinse	05700-021-84-61
3	1	Ball Valve, 1 1/2"	04820-111-71-46
4	1	AJX-44 Ball Valve Handle Assembly	05700-021-84-74
5	1	Elbow, 1 1/2", 90-degree, Street Brass	04730-206-32-00
6	1	Nipple, 1 1/2", Close Brass	04730-207-40-00
7	1	Fitting, Barbed, 1 1/2" x 1 1/2"	04730-011-69-92

PARTS

AJX-66/76/80/90 DRAIN PLUMBING, L-R

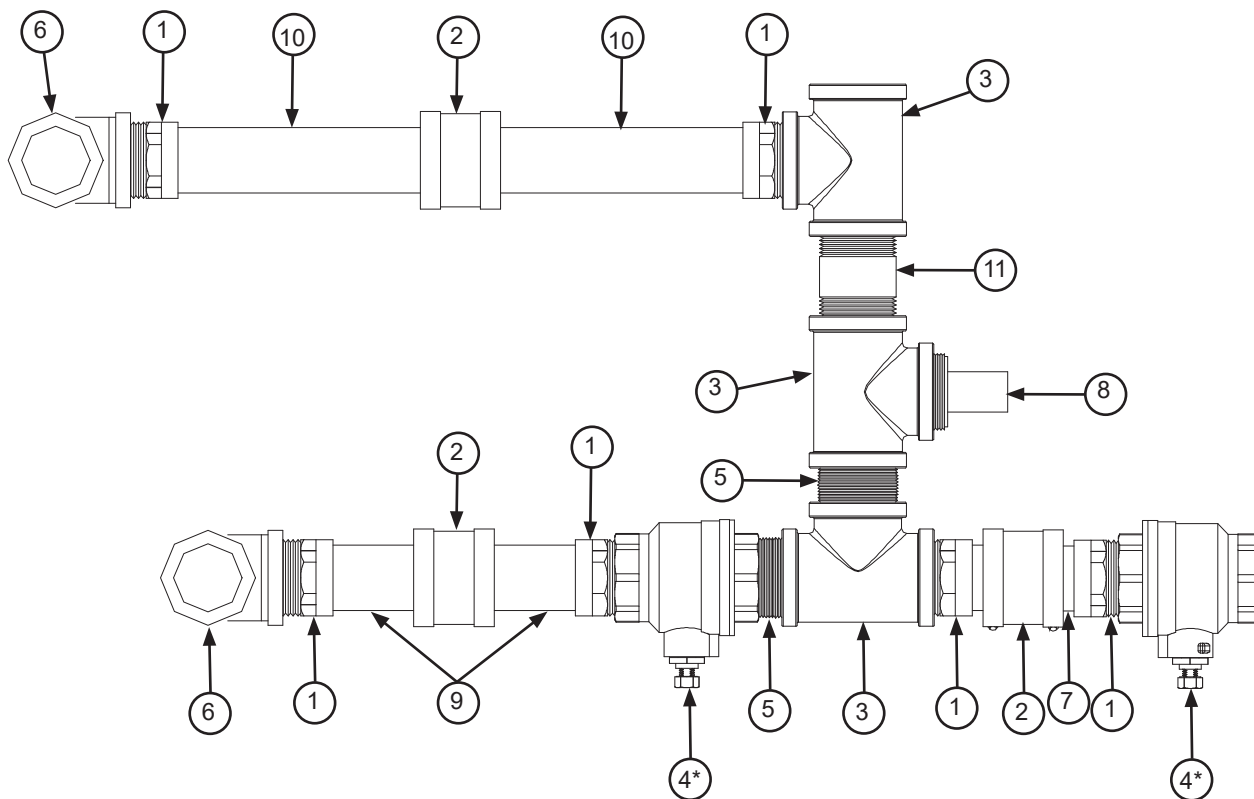

ITEM	QTY	DESCRIPTION	PART NUMBER
1	6	Adapter, Male to Female, 1 1/2"	04730-401-25-01
2	3	Connector, No-hub, 1 1/2"	04720-003-73-73
3	3	Tee, Brass, 1 1/2"	04730-011-69-93
4	2	Ball Valve, 1 1/2"	04820-011-71-46
	2	Valve Handle Assembly (Not Shown)	06401-021-84-74
5	2	Nipple, Close Brass, 1 1/2"	04730-207-40-00
6	2	Elbow, Brass, 90-degree, 1 1/2"	04730-011-73-77
7	2	Tube, Copper, 1 1/2" x 1 3/4" (All Models)	See note below.
8	1	Nipple, Rinse	05700-021-84-61
9	2	Tube, Copper, 1 1/2" x 3 1/2" (AJX-66), 1 1/2" x 6 1/2" (AJX-76) 1 1/2" x 10 1/4" (AJX-80), 1 1/2" x 11 1/2" (AJX-90)	See note below.
10	2	Tube, Copper, 1 1/2" x 7 1/2" (AJX-66), 1 1/2" x 10 1/4" (AJX-76) 1 1/2" x 14" (AJX-80), 1 1/2" x 15 1/4" (AJX-90)	See note below.
11	1	Nipple, Brass, 1 1/2" x 3"	04730-011-87-04

NOTICE Copper tubing should be purchased locally and cut to the length shown in the part description.

PARTS

AJX-66/76/80/90 DRAIN PLUMBING, R-L

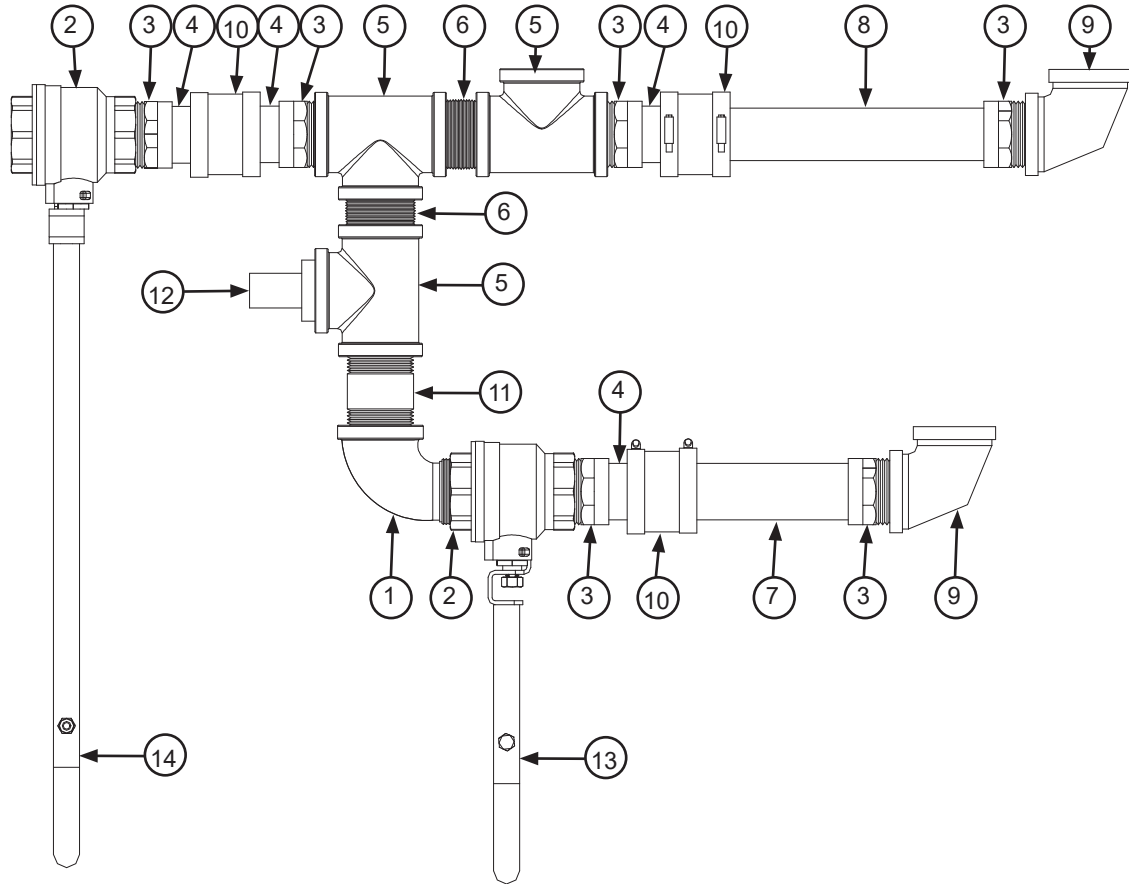

ITEM	QTY	DESCRIPTION	PART NUMBER
1	1	Elbow, 1 1/2", Street Brass	04730-206-32-00
2	2	Ball Valve, 1 1/2"	04820-011-71-46
3	6	Adapter, Male to Female, 1 1/2"	04730-401-25-01
4	4	Tube, Copper, 1 1/2" x 1 7/8" (All Models)	See note below.
5	3	Tee, Brass, 1 1/2"	04730-011-69-93
6	2	Nipple, Close Brass, 1 1/2"	04730-207-40-00
7	2	Tube, Copper, 1 1/2" x 5 3/16" (AJX-66), 1 1/2" x 10 3/16" (AJX-76) 1 1/2" x 14 3/16" (AJX-80), 1 1/2" x 19 3/16" (AJX-90)	See note below.
8	2	Tube, Copper, 1 1/2" x 8 1/8" (AJX-66), 1 1/2" x 13 1/8" (AJX-76) 1 1/2" x 17 1/8" (AJX-80), 1 1/2" x 22 1/8" (AJX-90)	See note below.
9	2	Elbow, Brass, 90-degree, 1 1/2"	04730-011-73-77
10	3	Connector, No-hub, 1 1/2"	04720-003-73-73
11	1	Nipple, Brass, 1 1/2" x 3"	04730-011-87-04
12	1	Nipple, Rinse	05700-021-84-61
13	1	Valve Handle Assembly	05700-021-84-74
14	1	Valve Handle Assembly	05700-002-57-82

NOTICE Copper tubing should be purchased locally and cut to the length shown in the part description.

Complete Drain Water Tempering System
05700-002-44-07

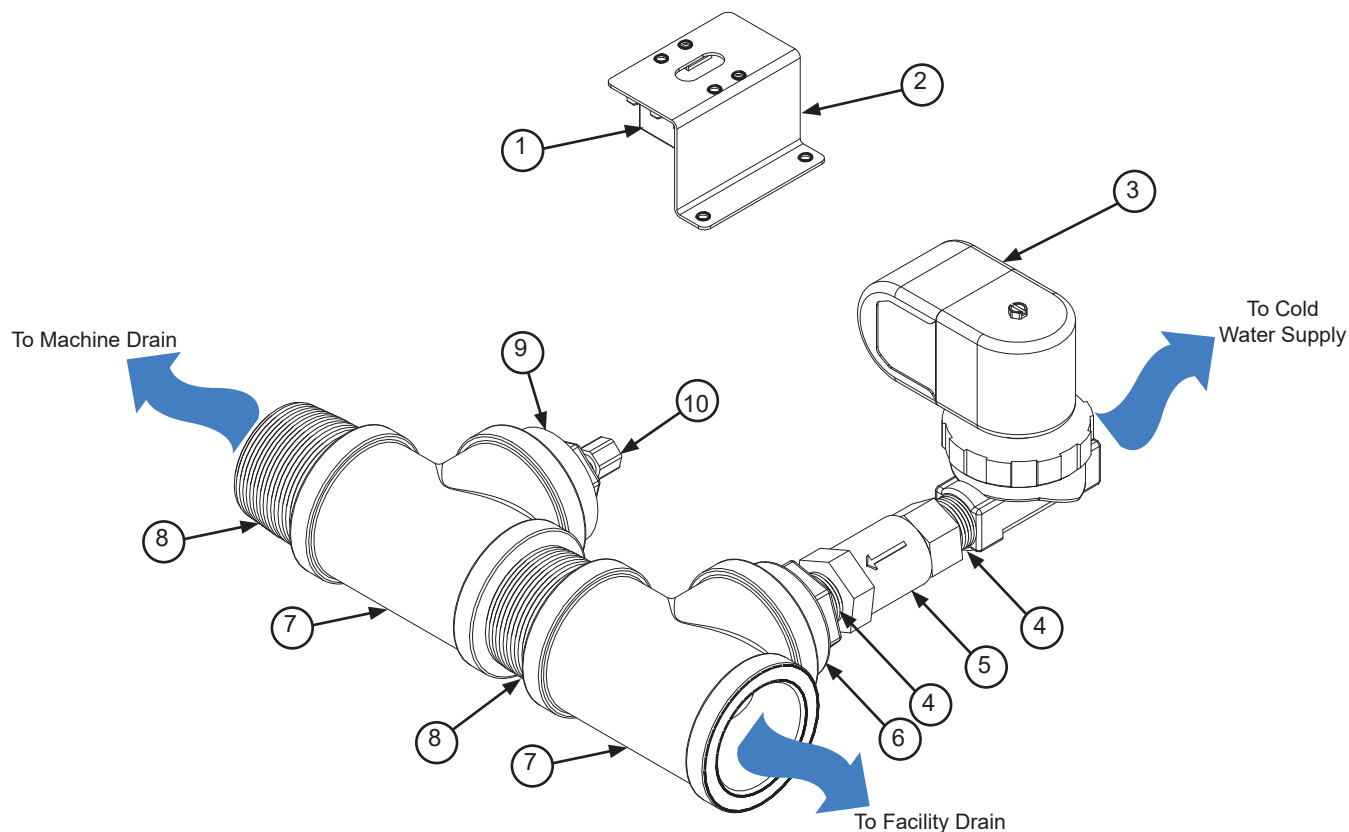

From the existing drain, attach the two additional Tees (Item 7) using the 1 1/2" Close Brass Nipples (Item 8). Tighten the Reducers (Items 6 and 9) into the Tees as shown above. Attach the Modified Compression Fitting (Item 10) into the 1 1/2" to 1/4" Reducer (Item 9). Position the bulb of the thermostat (Item 1) so that it rests approximately 1/4" from the bottom of the Tee (Item 7). Tighten the Modified Compression Fitting (Item 10) as required.

Mount the Thermostat (Item 1) to the tub using the Thermostat Bracket (Item 2) and set it for 120–140 °F. Install the Solenoid Valve (Item 3) to the second Tee (Item 7) and then attach to the incoming cold water line. Use thread tape as required to prevent any leaks.

ITEM	QTY	DESCRIPTION	PART NUMBER
1	1	Thermostat	05930-003-13-65
2	1	Thermostat Bracket	05700-011-81-64
3	1	Solenoid Valve	04810-100-12-18
4	2	Nipple, Close Brass, 1/2"	04730-207-15-00
5	1	Valve, Check, 1/2"	04820-002-55-77
6	1	Reducer, 1 1/2" to 1/2"	04730-002-55-75
7	2	Tee, 1 1/2" x 1 1/2" x 1 1/2"	04730-011-69-93
8	2	Nipple, Close Brass, 1 1/2"	04730-207-40-00
9	1	Reducer, 1 1/2" to 1/4"	04730-002-55-76
10	1	Modified Compression Fitting	05700-001-16-52

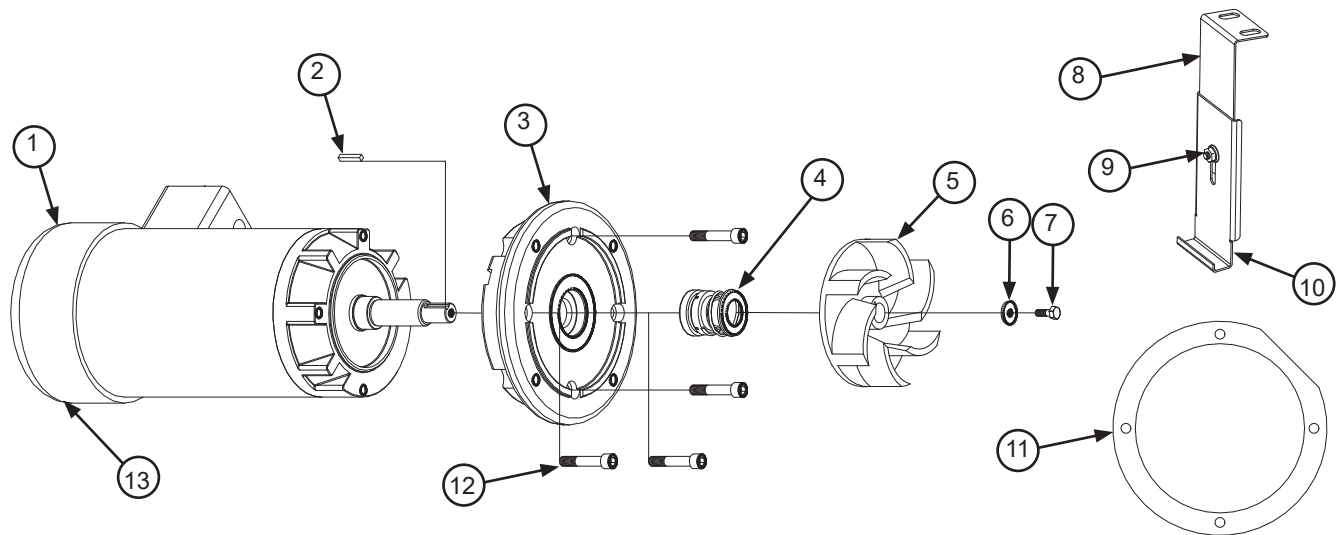

ITEM	QTY	DESCRIPTION	PART NUMBER
1	1	Motor	See table on the next page.
2	1	Key, 3/16" x 1"	05700-011-89-17
3	1	Pump Plate	05700-021-71-83
4	1	Pump Seal	05330-011-71-98
5	1	Impeller (AJX-44/54)	05700-031-67-45
	1	Impeller (AJX-66/76/80/90)	05700-031-71-78
6	1	Impeller Washer	05700-011-71-95
7	1	Bolt, Hex Head 1/4-20 x 3/4"	05305-004-42-64
8	1	Upper Support Bracket	05700-021-73-68
9	1	Nut, 1/4-20 Serrated	05310-011-66-49
10	1	Lower Support Bracket	05700-021-73-71
11	1	Motor Mounting Gasket	05330-011-71-62
12	1	Cap Screw, 3/8-16 x 2"	05305-011-74-98
13	1	Motor Mounting Clamp, 4 1/8" - 7" (Not Shown)	04730-002-32-15

Complete Motor Bracket Assembly
 Items 8,9, and 10
 05700-021-73-42

WASH MOTORS

Volts	Phase	Hz	Motor Part Number	Complete Kit Part Number
200-440	3	50	06105-121-81-34	06401-003-09-96
208-230	1	60	06105-021-70-57	06401-003-09-97
200-230	3	60	06105-121-70-58	06401-003-09-98
380	3	60	06105-121-81-34	06401-003-09-96
460	3	60	06105-121-70-58	06401-003-09-98
600	3	60	06105-002-48-31	06401-003-09-98

PRE-WASH MOTORS

AJX-66/76

Volts	Phase	Hz	Motor Part Number	Complete Kit Part Number
208-230	3	50	06105-121-70-56	06401-003-10-38
380	3	50	06105-121-81-34	06401-003-10-39
415	3	50	06105-121-81-34	06401-003-10-39
440	3	50	06105-121-70-56	06401-003-10-38
208-230	1	60	06105-121-70-55	06401-003-10-40
200-230	3	60	06105-121-70-56	06401-003-10-38
380	3	60	06105-121-70-56	06401-003-10-38
460	3	60	06105-121-70-56	06401-003-10-38
600	3	60	06105-002-48-31	06401-003-10-41

AJX-80/90

Volts	Phase	Hz	Motor Part Number	Complete Kit Part Number
208-230	3	50	06105-121-81-34	06401-003-10-39
380	3	50	06105-121-81-34	06401-003-10-39
415	3	50	06105-121-81-34	06401-003-10-39
440	3	50	06105-121-81-34	06401-003-10-39
208-230	1	60	06105-021-70-57	06401-003-10-42
200-230	3	60	06105-121-70-58	06401-003-10-43
380	3	60	06105-121-81-34	06401-003-10-39
460	3	60	06105-121-70-58	06401-003-10-43
600	3	60	06105-002-48-31	06401-003-10-41

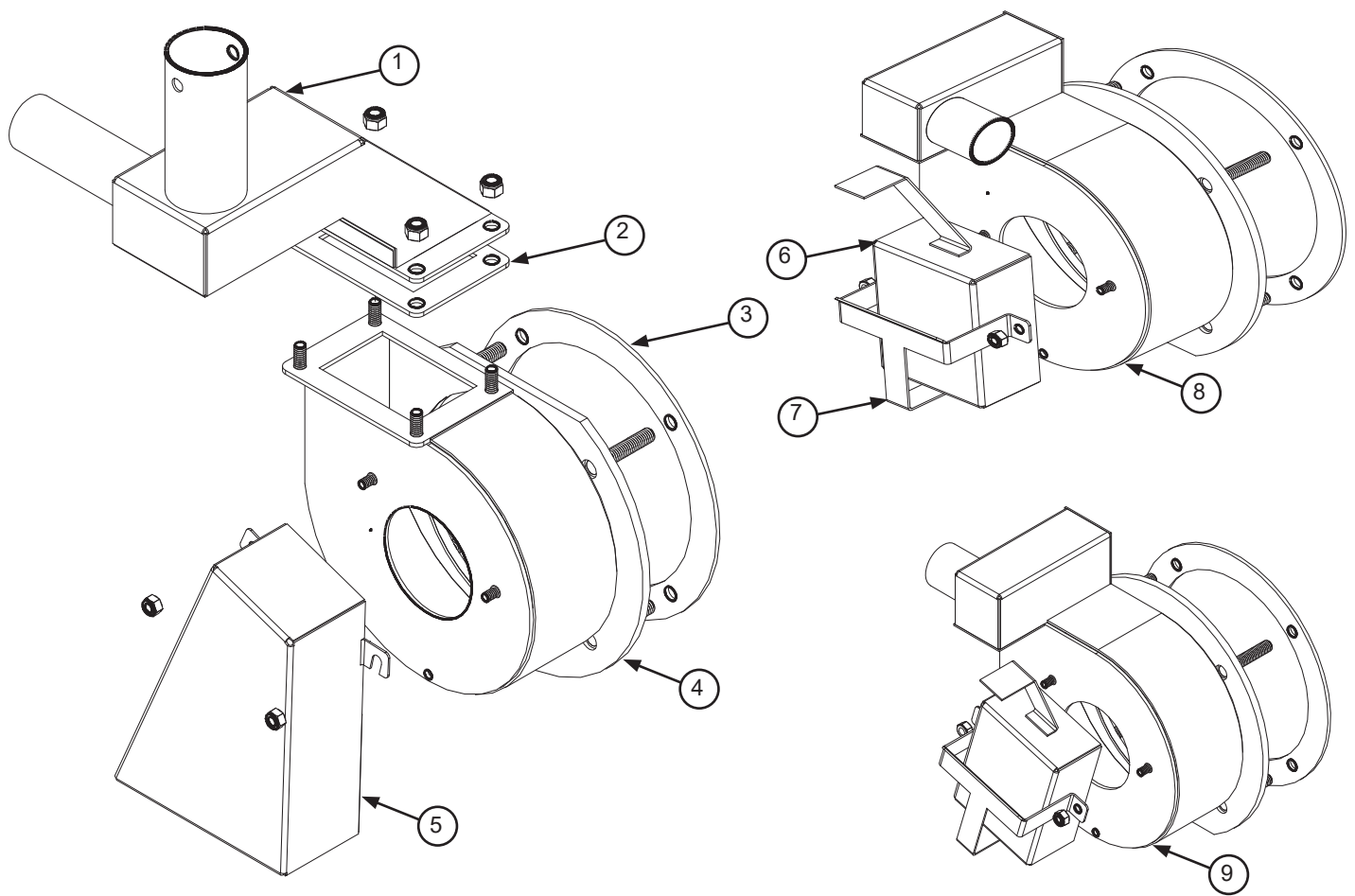

ITEM	QTY	DESCRIPTION	PART NUMBER
1	1	Pump Discharge	05700-002-50-90
2	1	Gasket	05330-002-54-55
3	1	Motor Mounting Gasket	05330-011-71-62
4	1	Wash Pump	05700-002-50-92
5	1	Intake Suction Scoop	05700-002-51-20
6	1	Pre-wash Intake Strainer	05700-021-74-96
7	1	Pre-wash Strainer Bracket	05700-021-74-94
8	1	Pre-wash Pump, AJX-66/76/80/90, L-R	05700-002-43-56
9	1	Pre-wash Pump, AJX-66/76/80/90, R-L	05700-002-42-69

Complete Lower Wash Arm Assembly, 50 Hz Machines
05700-002-24-86

Complete Lower Wash Arm Assembly, 60 Hz Machines
05700-031-74-66

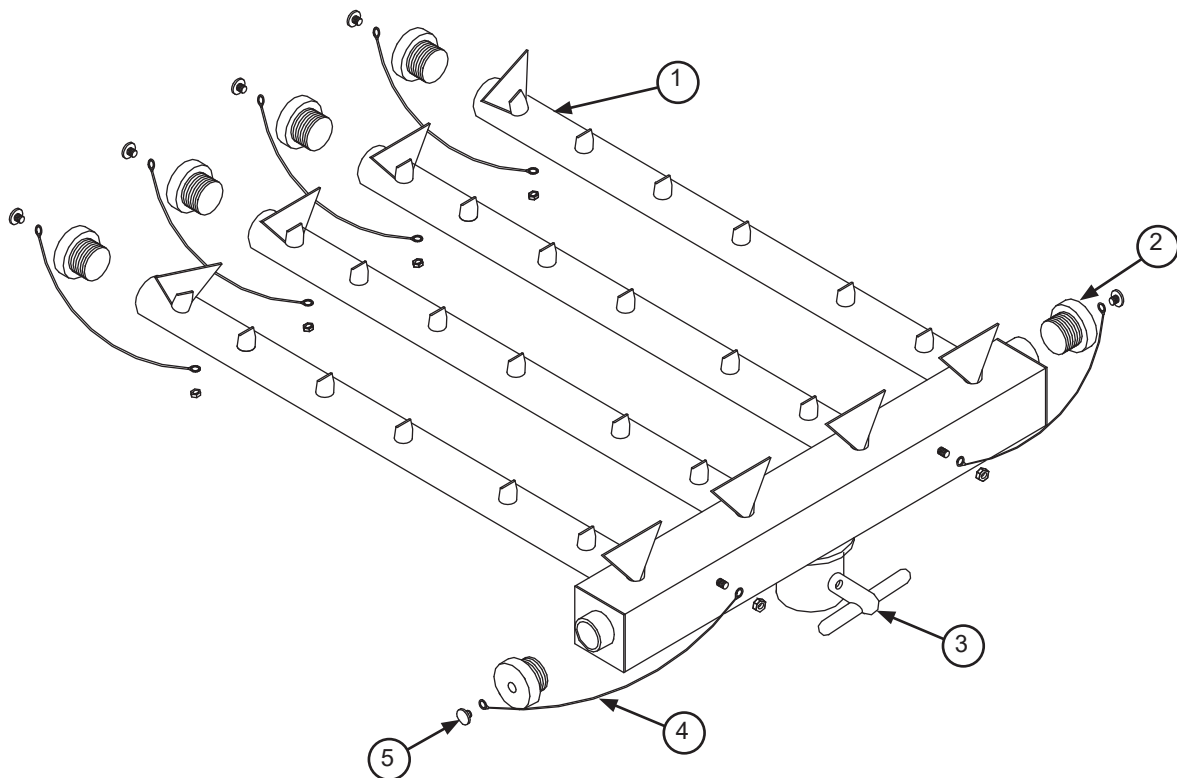

ITEM	QTY	DESCRIPTION	PART NUMBER
1	1	Lower Wash Arm Manifold, 50 Hz Machines	05700-002-24-87
	1	Lower Wash Arm Manifold, 60 Hz Machines	05700-031-67-29
2	6	End-cap	05700-011-67-11
	6	End-cap Replacement Kit*	06401-003-10-19*
3	1	Manifold Quick-Release Key	05700-011-94-45
4	6	Lanyard	05340-011-72-46
5	6	Mounting Screw, End-cap, 10-32 x 3/8"	05305-173-12-00

*Kit includes the end-cap, lanyard, and mounting screw.

NOTICE When replacing the screws in the end-caps, use a thread-locking product to ensure the mounting screws do not come loose during operation.

PRE-WASH ARM & UPPER WASH ARM

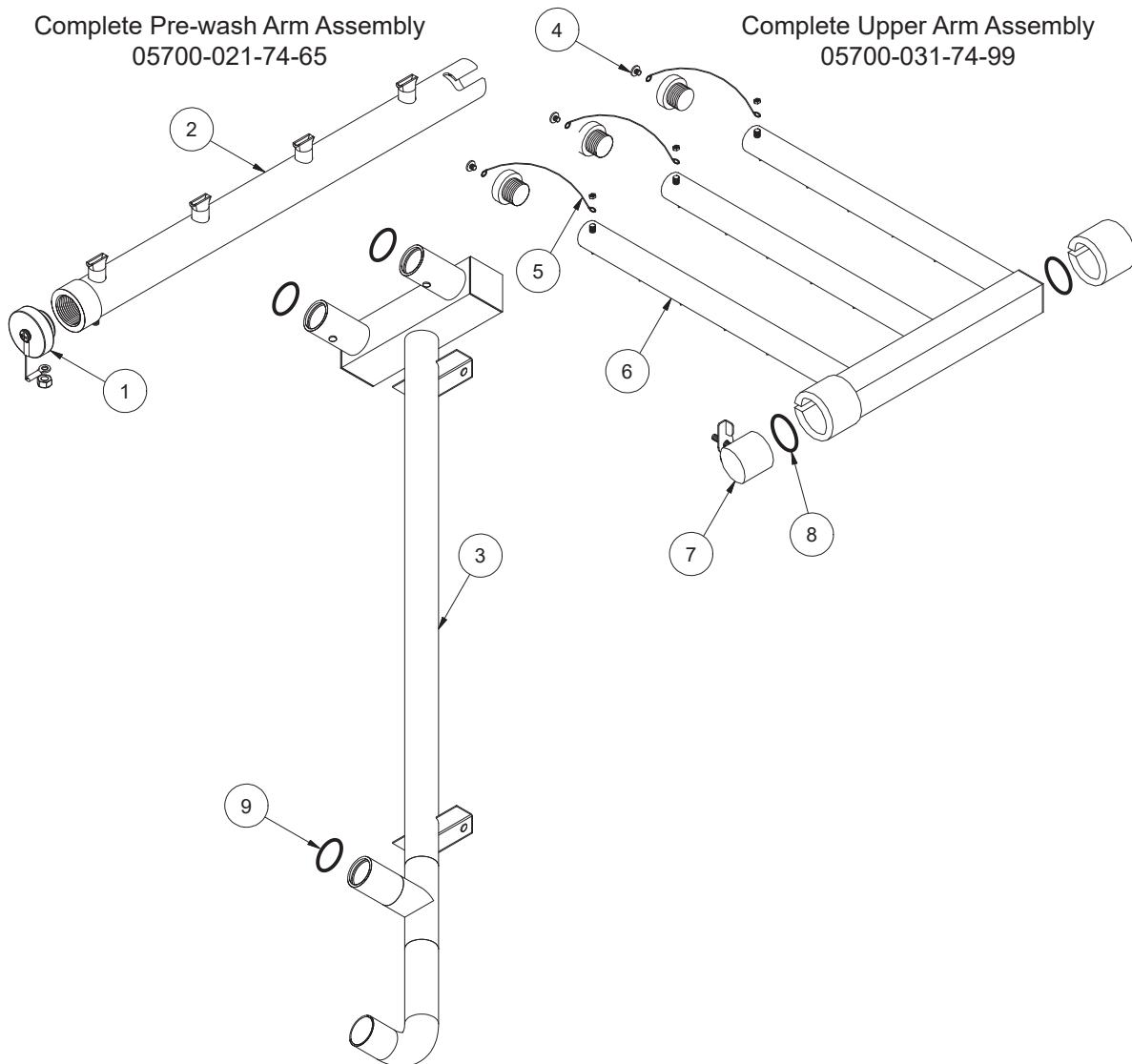

ITEM	QTY	DESCRIPTION	PART NUMBER
1	4	End-cap	05700-011-67-11
	4	End-cap Replacement Kit*	06401-003-10-19*
2	1	Pre-wash Tube (AJX-66/76/80/90)	05700-001-16-89
3	1	Pre-wash Manifold (AJX-66/76/80/90)	05700-031-69-70
4	4	Mounting Screw, End-cap, 10-32 x 3/8"	05305-173-12-00
5	4	Lanyard	05340-011-72-46
6	1	Upper Wash Arm	05700-031-67-34
7	1	Cap, Wash Tube	05700-021-69-68
8	2	O-ring, Upper Wash Arm	05330-011-74-56
9	3	O-ring, Pre-wash Manifold	05330-400-12-08
10	1	Upper Wash Manifold Support Bracket (Not Shown)	05700-021-73-97

* Kit contains part(s) and all hardware.

NOTICE When replacing the screws in the end-caps, use a thread-locking product to ensure the mounting screws do not come loose during operation.

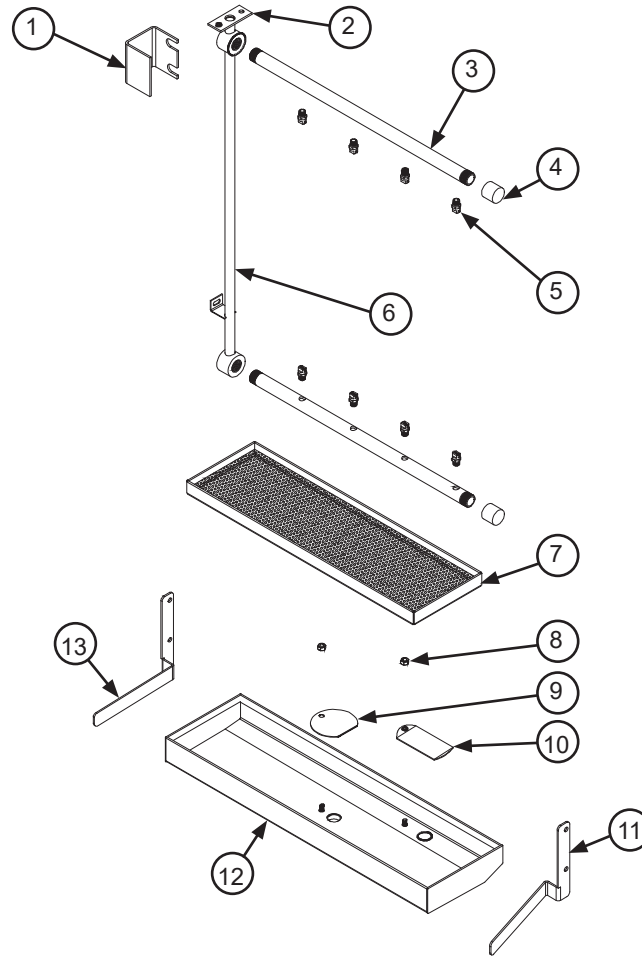

ITEM	QTY	DESCRIPTION	PART NUMBER
1	1	Rinse Arm Support Bracket	05700-002-06-24
2	1	Gasket, Final Rinse Manifold	05330-111-42-81
3	2	Rinse Arm	05700-002-02-18
4	2	End-cap	05700-002-02-19
5	8	Rinse Nozzle	04730-003-59-63
6	1	Final Rinse Manifold	05700-002-97-41
7	1	Rinse Pan Strainer	05700-041-85-09
8	2	Locknut, 1/4-20 with Nylon Insert	05310-374-01-00
9	1	Rinse Drain Control Plate	05700-011-68-70
10	1	Rinse Drain Overflow Plate	05700-002-53-62
11	1	Left Rinse Pan Locator Bracket	05700-021-92-38
12	1	Rinse Tray	05700-002-51-18
13	1	Right Rinse Pan Locator Bracket	05700-021-92-37

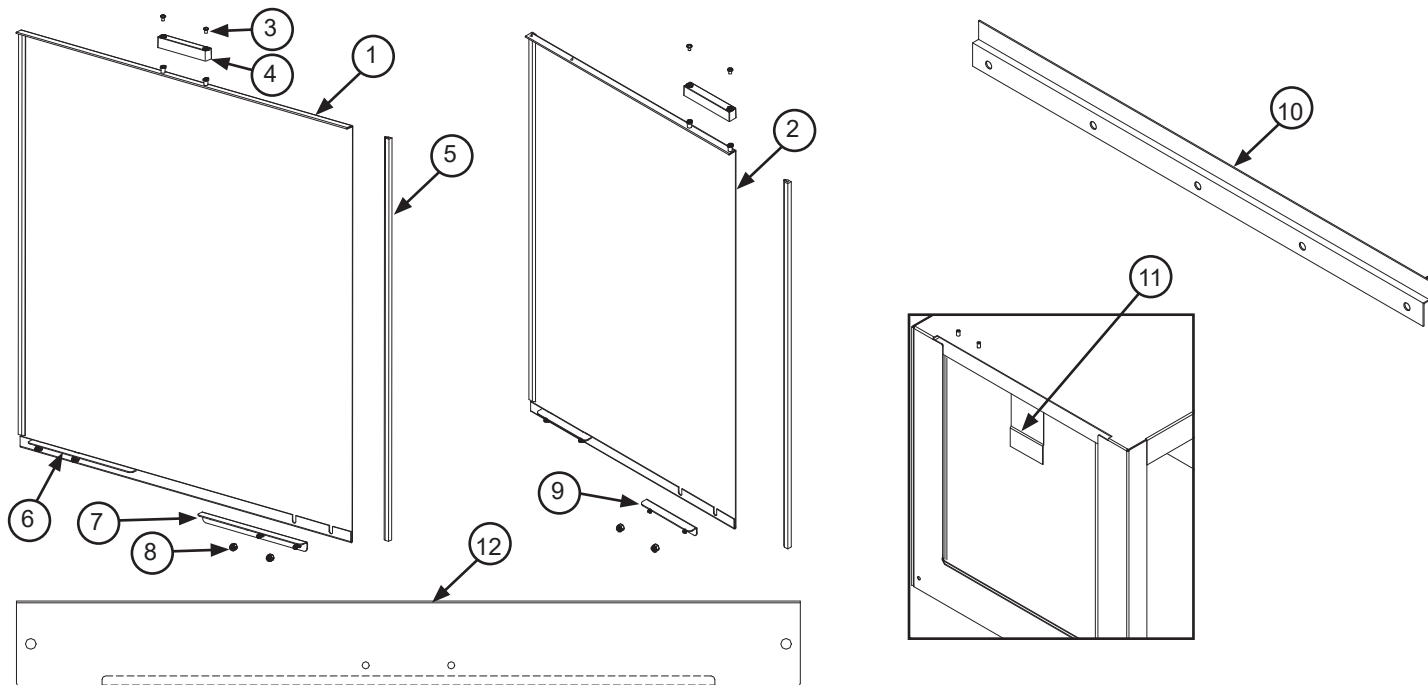

ITEM	QTY	DESCRIPTION	PART NUMBER
1	1	Door	05700-003-13-47
2	1	Pre-wash Door, Left-to-Right	05700-003-13-42
	1	Pre-wash Door, Right-to-Left	05700-003-13-40
3	1	Screw, 8-32 x 1/4"	05305-172-09-00
4	1	Door Switch Magnet	05700-111-51-68
5	2	Door Guide	05700-111-70-92
6	1	Bracket, Right Door Stop	05700-002-96-33
7	1	Bracket, Left Door Stop	05700-002-96-32
8	4	Locknut, 10-24 Hex with Nylon Insert	05310-373-01-00
9	2	Bracket, Pre-wash Door Stop	05700-002-05-46
10	1	Left Door Guide	05700-002-32-51
	1	Right Door Guide	05700-031-76-44
11	1	Door Catch	05700-031-84-80
12	1	Door Hood Support	05700-031-84-13
	1	Pre-wash Door Hood Support	05700-031-84-14
13	1	Door Stiffener (Not Shown)	05700-031-83-43

Complete Drive Assembly
05700-003-60-69

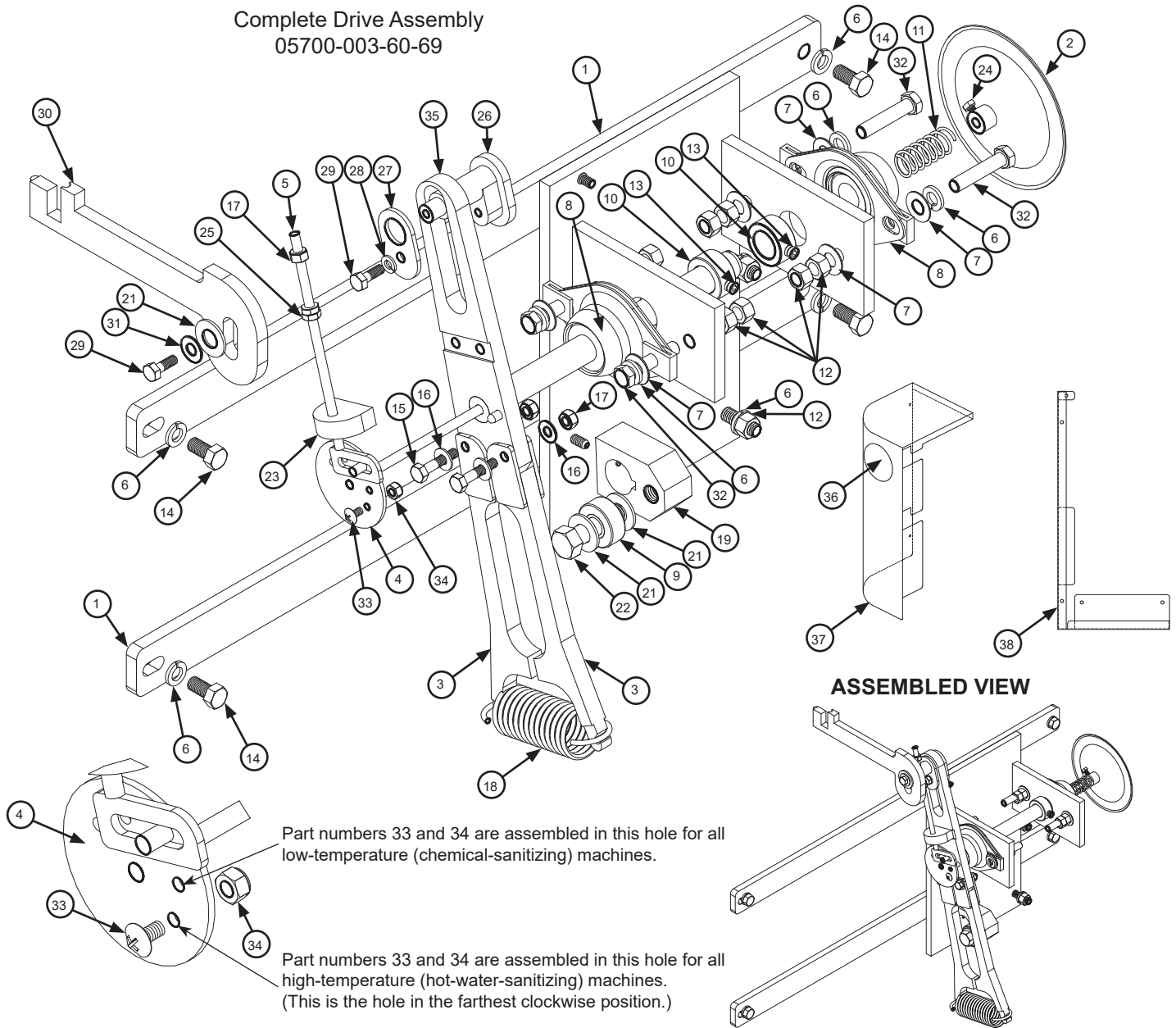

ITEM	QTY	DESCRIPTION	PART NUMBER
1	1	Mounting Bracket Drive Motor	05700-031-73-56
2	1	Adjuster, Handle	05700-021-72-28
3	2	Coupling & Expansion Legs	05700-021-67-50
4	1	Adjuster, Crank Assembly	05700-021-69-95
5	1	Adjuster, Scotch Yoke	05700-021-69-76
6	12	Lockwasher, 3/8"	05311-276-01-00
7	8	Flat Washer, 3/8"	05311-176-01-00
8	2	Block, Pillow	03120-021-71-87
9	1	Bearing, Roller	03120-011-71-81

ITEM	QTY	DESCRIPTION	PART NUMBER
10	2	Collar, Shaft Conveyor Drive	05700-011-89-18
11	1	Spring, Adjuster	05315-011-71-90
12	12	Nut, Hex, 3/8-16	05310-276-01-00
13	2	Set Screw, 5/16-18 x 1/4"	05305-002-98-39
14	4	Bolt, 3/8-16 x 3/4"	05306-011-71-60
15	2	Bolt, 1/4-20 x 1/4"	05305-274-22-00
16	4	Washer, 1/4-20	05311-174-01-00
17	3	Locknut, 1/4-20 Hex with Nylon Insert	05310-374-01-00
18	1	Spring, Drive	05315-011-83-51
19	1	Hub, Drive	05700-011-67-97
20	1	Set Screw, 1/4-20 x 1/2"	05305-011-71-51
21	3	Flat Washer, 1/2"	05311-011-71-93
22	1	Bolt, 1/2-13 x 1 3/4"	05305-011-71-94
23	1	Plate, Drive Rod	05700-021-67-42
24	1	Bolt, 10-32 x 3/8" Hex Head	05306-011-62-45
25	2	Nut, Hex, 1/4-20	05310-274-01-00
26	1	Socket, Drive	05700-021-67-39
27	1	Plate, Spacer	05700-011-67-58
28	1	Lockwasher, Spring, 1/4"	05311-274-01-00
29	2	Bolt, Hex Head 1/4-20 x 3/4"	05305-004-42-64
30	1	Casting, Pawl Bar Drive Linkage	09515-021-87-73
31	1	Washer, 5/16-18	05311-175-01-00
32	4	Bolt, 3/8-16 x 1 3/4"	05306-011-36-94
33	1	Screw, 10-24 x 3/8"	05305-173-03-00
34	1	Locknut, 10-24 Hex with Nylon Insert	05310-373-01-00
35	1	Drive Plate and Rod	05700-021-67-44
36	1	Decal, Drive Adjuster	09905-003-61-01
37	1	Front Drive Motor Cover	05700-031-69-39
38	1	Rear Drive Motor Cover	05700-002-41-21
39	1	Gear Drive (Not Shown)	06105-011-71-88
Drive Motors	1	Drive Motor (50 Hz Machines)	06401-003-08-41
	1	Drive Motor (208-230 V, 60 Hz, Single-Phase Machines)	06401-003-08-42
	1	Drive Motor (208-230 V, 60 Hz, Three-Phase Machines)	06401-003-08-40
	1	Drive Motor (460 V, 60 Hz, Three-Phase Machines)	06401-003-08-43
	1	Drive Motor (600 V, 60 Hz, Three-Phase Machines)	06401-002-48-32

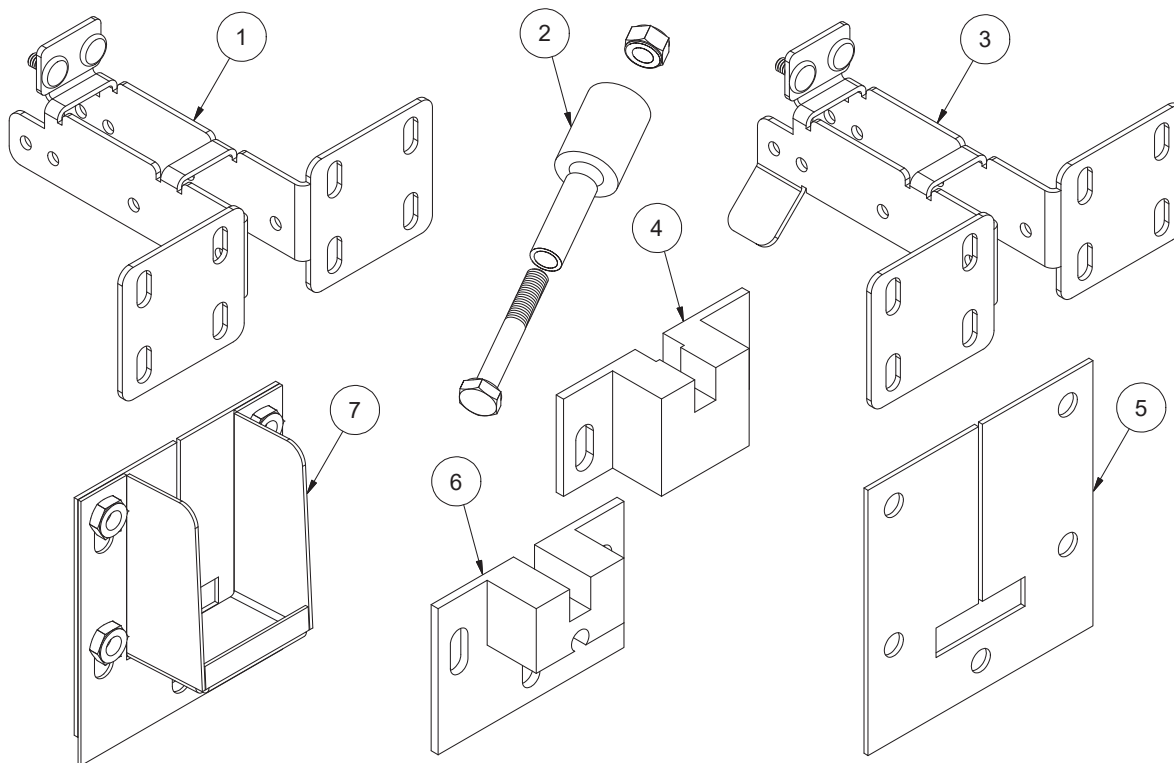

ITEM	QTY	DESCRIPTION	PART NUMBER
1	1	Pawl Bar Bracket (No Tabs)	05700-031-92-36
2	1	Pawl Bar Roller Replacement Kit ¹	06401-003-11-80
3	1	Pawl Bar Bracket (Tabs)	05700-031-84-68
4	1 1	Top Guide Block Guide Block Replacement Kit ²	05700-011-69-49 06401-003-10-15
5	1	Pawl Bar Gutter Gasket	05330-011-68-55
6	1	Bottom Guide Block	05700-011-69-50
7	1	Pawl Bar Gutter Replacement Kit ³	05700-021-74-94

¹Kit contains the roller, roller shaft, and hardware.

²Kit contains the top guide block, bottom guide block, and gasket.

³Kit contains the weldment, gasket, and hardware.

NOTICE When replacing one guide block, the other guide block and the gasket should be replaced as well.

Complete AJX-44 Pawl Bar Assembly with Hardware
06401-131-81-00

Complete AJX-66 Pawl Bar Assembly with Hardware
06401-141-74-64

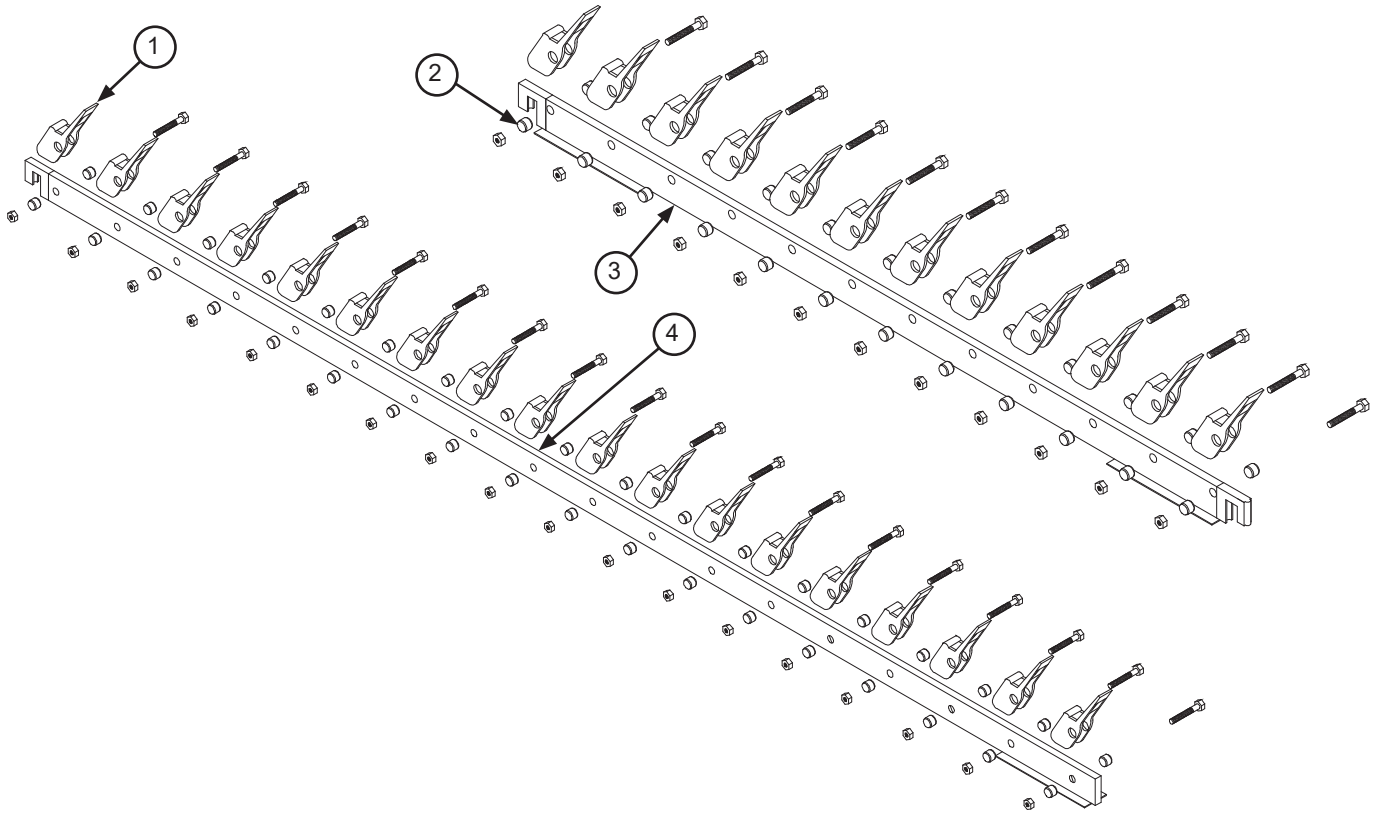

ITEM	QTY	DESCRIPTION	PART NUMBER
1	12 on AJX-44 18 on AJX-66	Pawl Bar Dog Casting	09515-021-69-00
2	24 on AJX-44 36 on AJX-66	Pawl Bar Spacer	05700-011-71-45
3	1	Pawl Bar (AJX-44)	05700-031-72-77
4	1	Pawl Bar (AJX-66)	05700-031-72-78

Complete AJX-80 Pawl Bar Assembly with Hardware, L-R
06401-131-81-06

Complete AJX-80 Pawl Bar Assembly with Hardware, R-L
06401-241-81-06

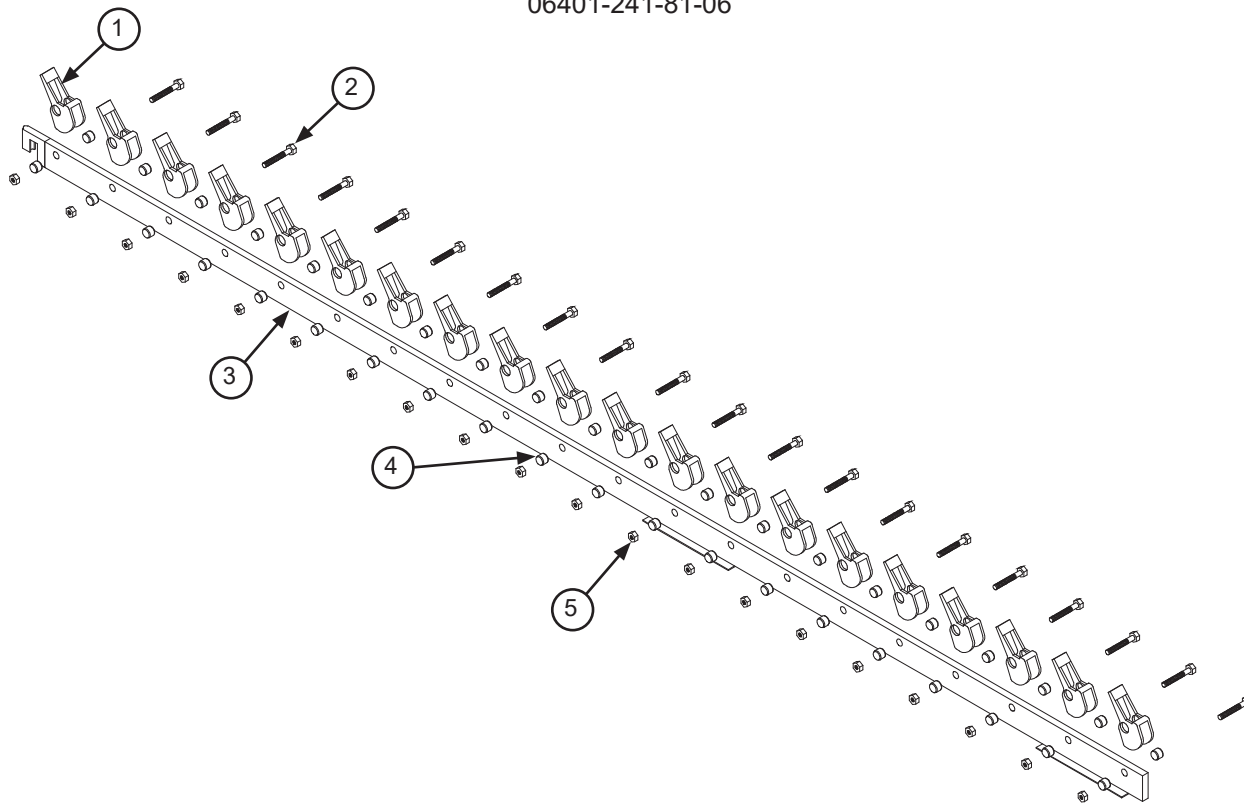

ITEM	QTY	DESCRIPTION	PART NUMBER
1	20	Pawl Bar Dog Casting ¹	09515-021-69-00
2	20	Bolt, 3/8-16 x 1-3/4" Long	05700-011-71-45
3	1 1	Pawl Bar (L-R) Pawl Bar (R-L)	05700-031-74-19 05700-041-82-01
4	40	Pawl Bar Spacer	05700-011-71-45
5	20	Locknut, 3/8-16 with Nylon Insert	05700-011-72-55

¹When replacing pawl bar dog castings, ensure to re-install in the appropriate direction. If not, the rack will not be pulled through the machine during operation.

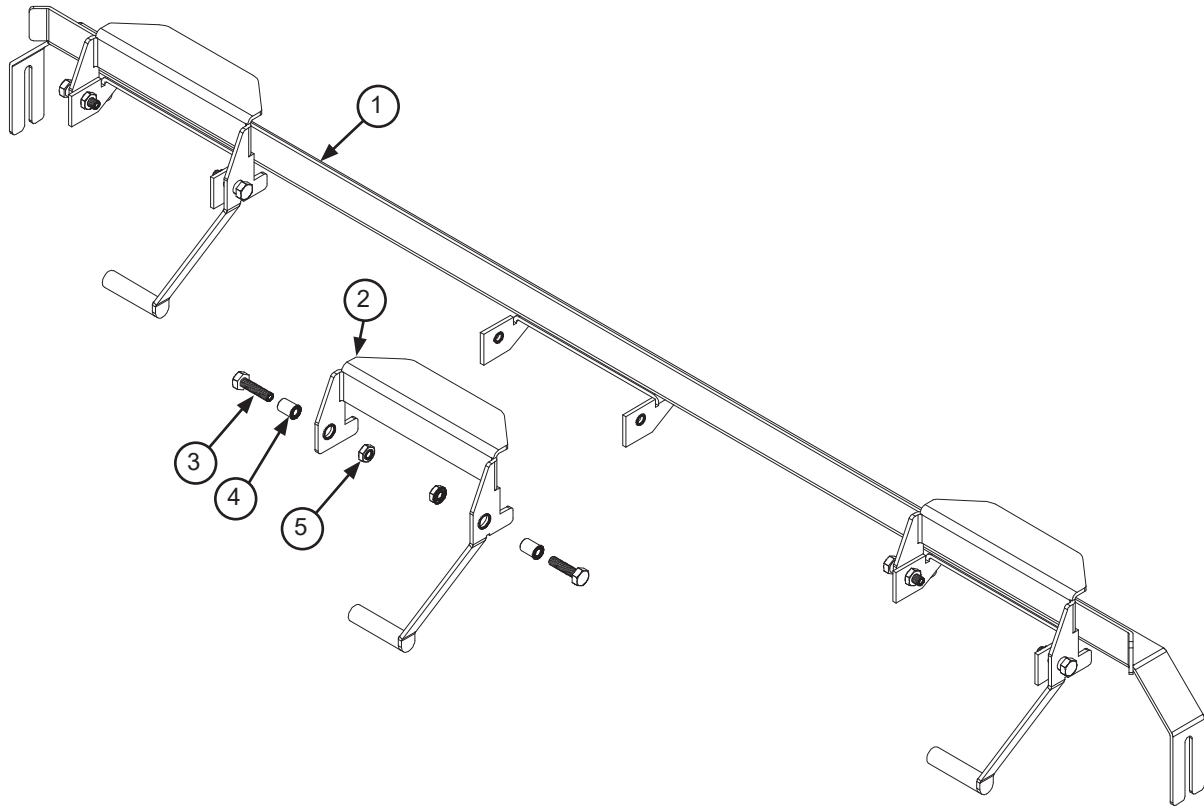

ITEM	QTY	DESCRIPTION	PART NUMBER
1	1 1	Rack Rail Opposite Rack Rail	05700-031-67-59 05700-031-69-48
2	3	Actuator Switch Actuator Switch Replacement Kit ¹	05700-021-72-39 06401-003-10-14
3	6	Bolt, Hex Head 1/4-20 x 3/4"	05305-004-42-64
4	6	Pawl Bar Spacer	05700-011-71-44
5	6	Locknut, 1/4-20 Hex with Nylon Insert	05310-374-01-00

¹Kit contains the switch, two spacers, and hardware.

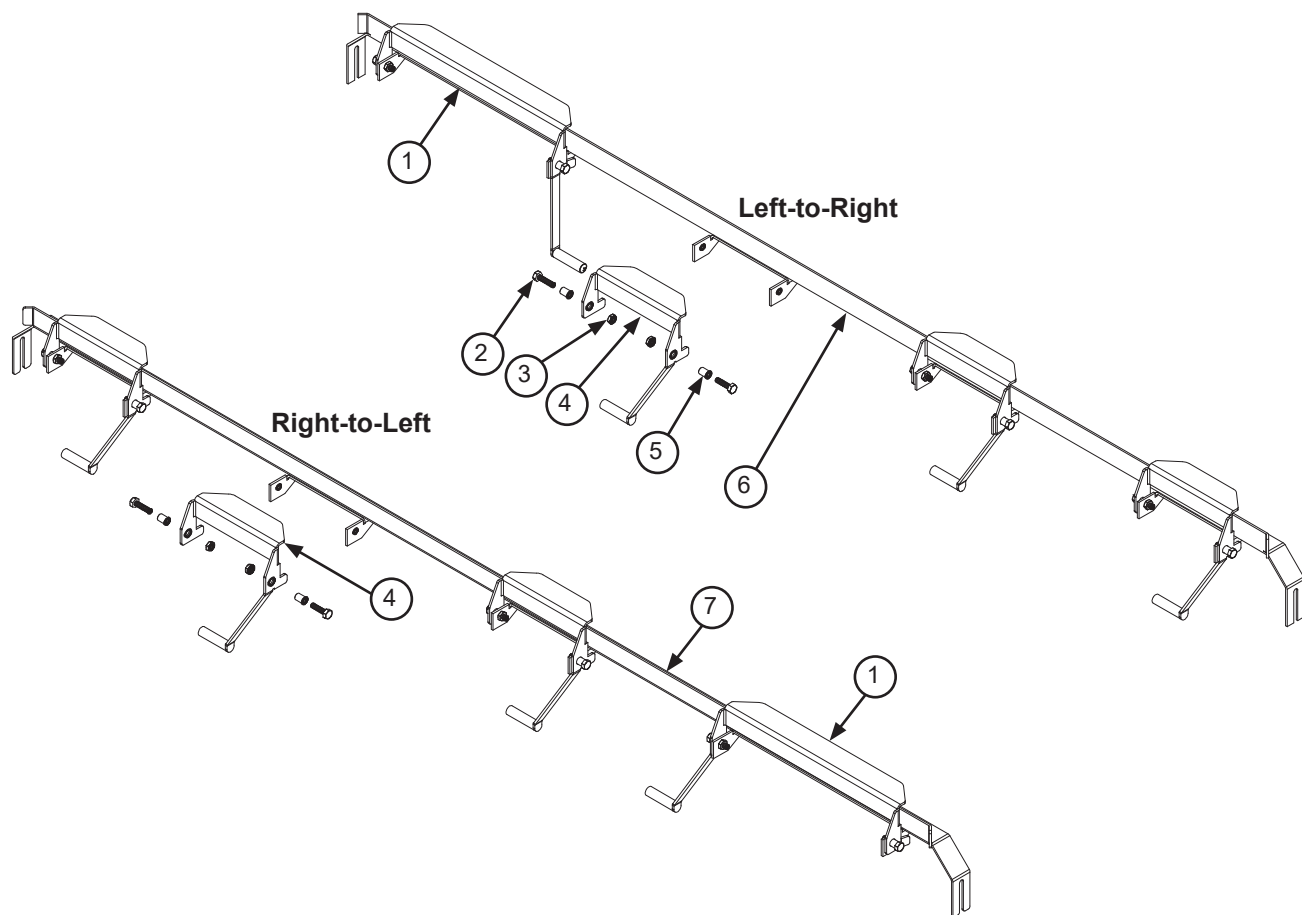

ITEM	QTY	DESCRIPTION	PART NUMBER
1	1	Large Actuator Switch, L-R	05700-021-76-97
		Large Actuator Switch Replacement Kit, L-R ¹	06401-003-10-99
	1	Large Actuator Switch, R-L	05700-002-91-09
		Large Actuator Switch Replacement Kit, R-L ¹	06401-003-10-86
2	8 per rail	Bolt, Hex Head 1/4-20 x 3/4"	05305-004-42-64
3	8 per rail	Locknut, 1/4-20 Hex with Nylon Insert	05310-374-01-00
4	3 per rail	Actuator Switch	05700-021-72-39
		Actuator Switch Replacement Kit ¹	06401-003-10-14
5	8 per rail	Pawl Bar Spacer	05700-011-71-44
6	1	Rack Rail, L-R	05700-031-76-27
		Opposite Rack Rail, L-R	05700-041-71-37
7	1	Rack Rail, R-L	05700-031-76-28
		Opposite Rack Rail, R-L	05700-041-69-54

¹Kits contain the switch, two spacers, and hardware.

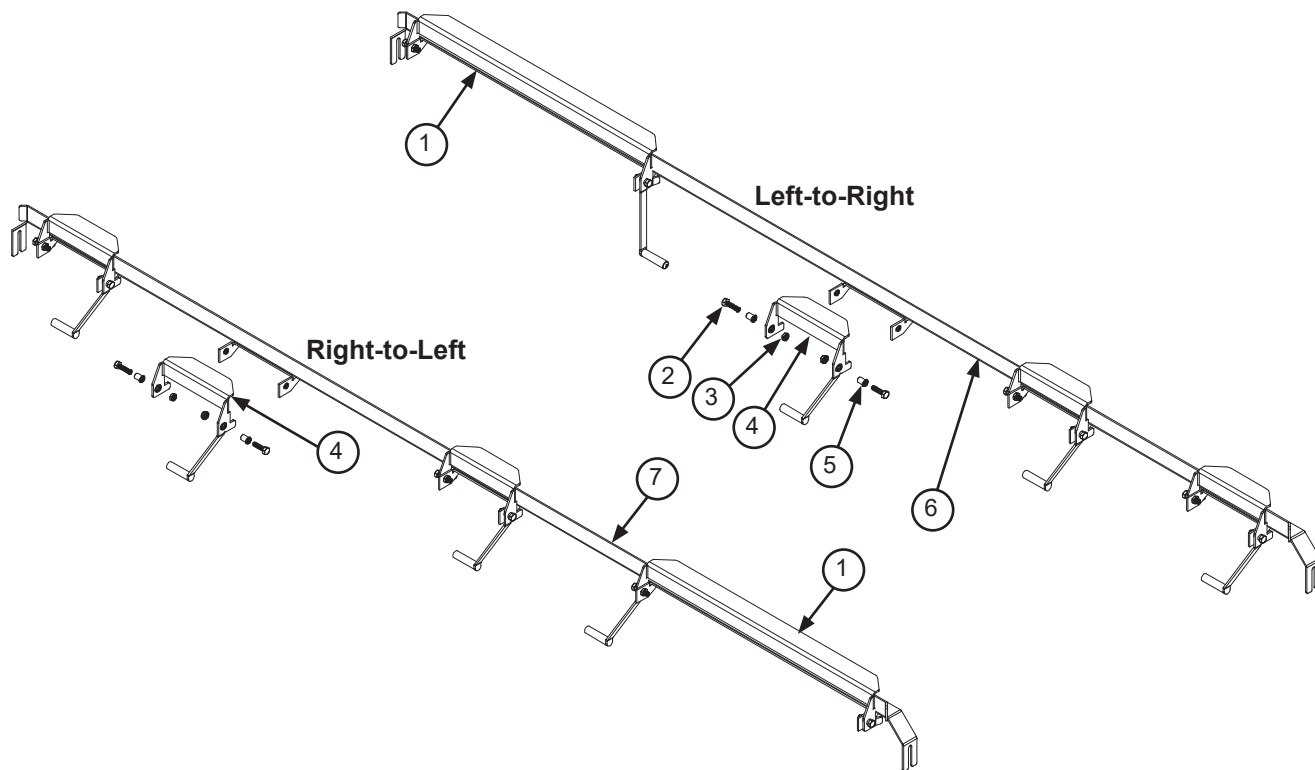

ITEM	QTY	DESCRIPTION	PART NUMBER
1	1	Large Actuator Switch, L-R	05700-021-77-01
	1	Large Actuator Switch Replacement Kit, L-R ¹	06401-003-10-83
	1	Large Actuator Switch, R-L	05700-002-91-10
	1	Large Actuator Switch Replacement Kit, R-L ¹	06401-003-10-85
2	8 per rail	Bolt, Hex Head 1/4-20 x 3/4"	05305-004-42-64
3	8 per rail	Locknut, 1/4-20 Hex with Nylon Insert	05310-374-01-00
4	3 per rail	Actuator Switch	05700-021-72-39
		Actuator Switch Replacement Kit ¹	06401-003-10-14
5	8 per rail	Pawl Bar Spacer	05700-011-71-44
6	1	Rack Rail, L-R	05700-031-81-53
		Opposite Rack Rail, L-R	05700-041-74-13
7	1	Rack Rail, R-L	05700-031-81-54
		Opposite Rack Rail, R-L	05700-041-74-14

¹Kits contain the switch, two spacers, and hardware.

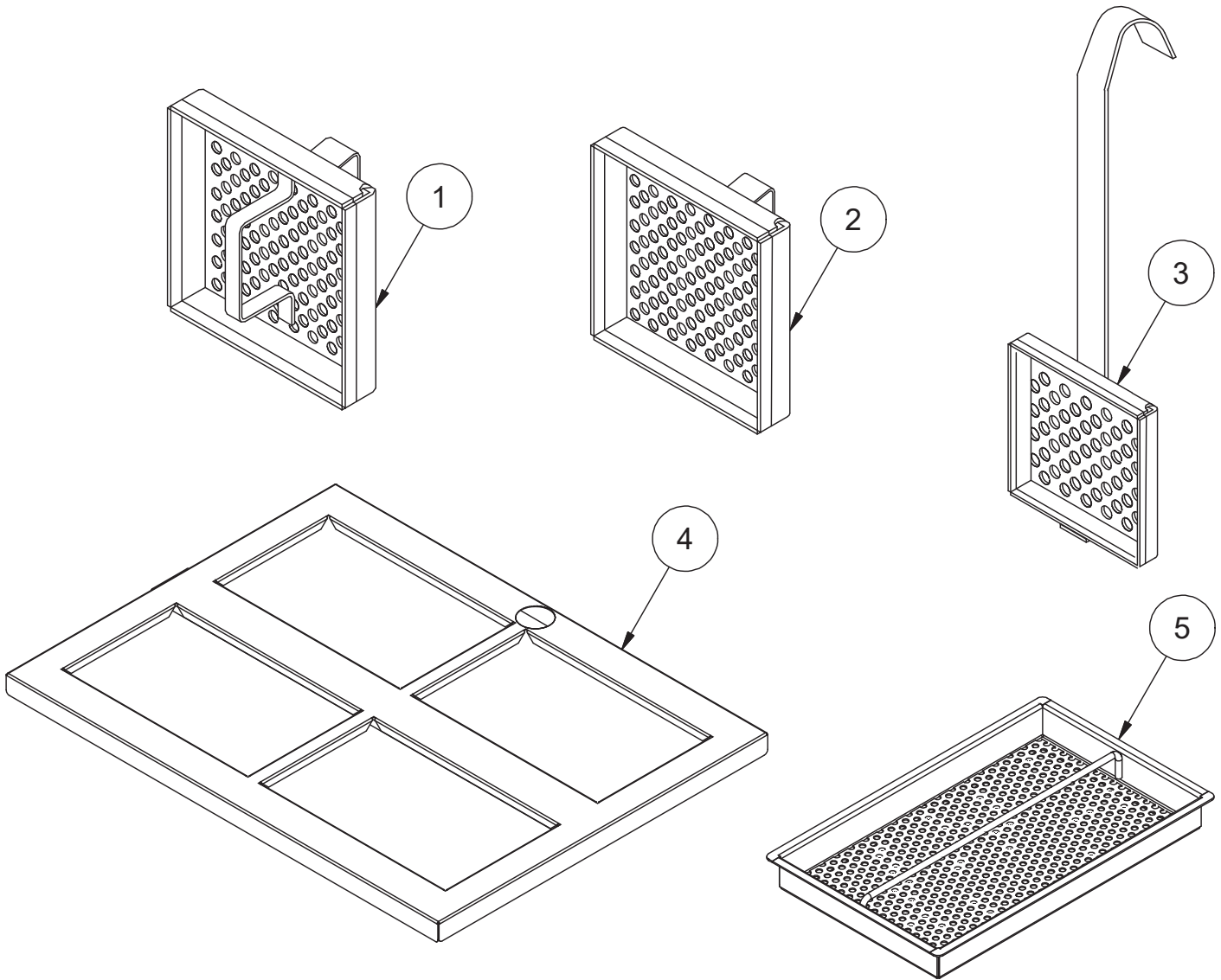

ITEM	QTY	DESCRIPTION	PART NUMBER
1	1	Drain Guard Strainer	05700-002-09-15
2	1	Screen Strainer with Handle	05700-002-09-04
3	1	Wash Intake Strainer	05700-001-22-23
4	1	Wash Strainer Separator	05700-002-90-84
5	1	Tub Strainer	05700-002-03-21

Complete Rinse Fill Motor Assembly
05700-002-40-25

Complete Rinse Fill Motor Assembly
(AJX-66 L-R Only)
05700-002-48-22

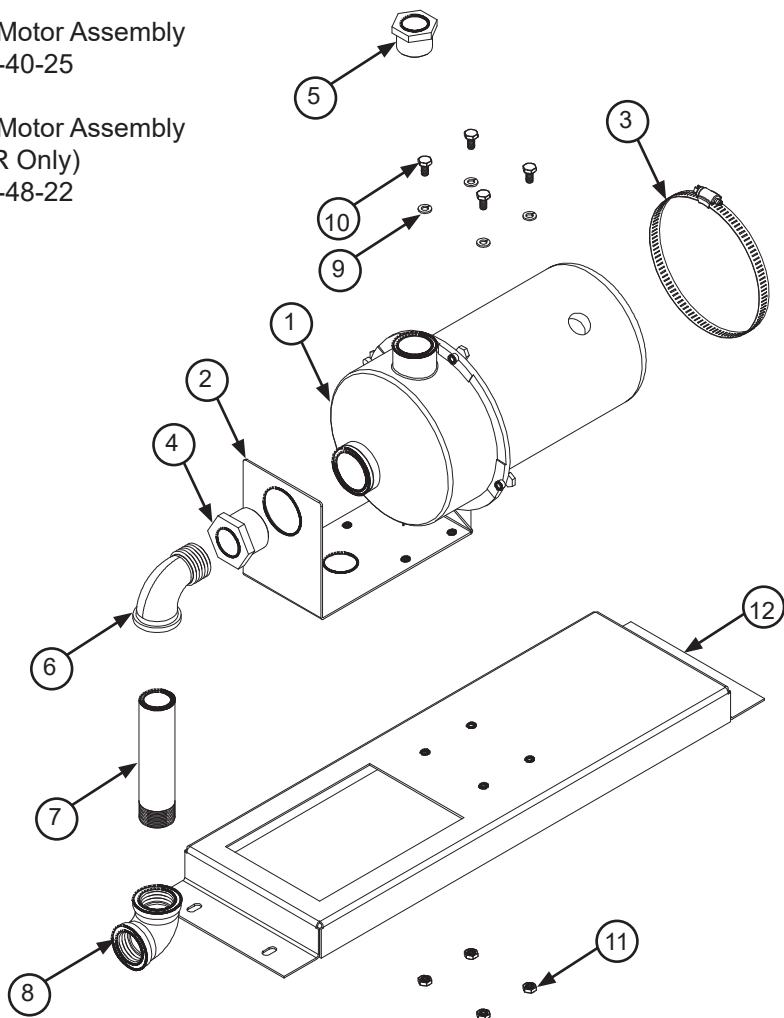

ITEM	QTY	DESCRIPTION	PART NUMBER
1	1	Motor	06105-002-72-71
2	1	Bracket, Pump Mounting	05700-003-17-56
3	1	Clamp, Hose 5 5/8" to 6"	04730-011-34-90
4	1	Reducer Bushing, 1 1/4" to 1"	04730-002-73-62
5	1	Reducer Bushing 1" to 3/4"	04730-011-65-14
6	1	Elbow, 90-Degree, 1" Street Brass	04730-002-11-99
7	1	Nipple, 1" x 6" Brass	04730-002-12-00
8	1	Elbow, 90-Degree, Brass Female	04730-002-12-55
9	4	Lockwasher, 1/4"	05311-274-01-00
10	4	Bolt, 1/4"-20 x 1/2"	05305-274-02-00
11	4	Nut, Hex 1/4-20	05310-274-01-00
12	1	Rinse Motor Mounting Bracket Rinse Motor Mounting Bracket (AJX-66 L-R Only)	05700-002-38-90 05700-002-39-33

Parts are not shown to scale with relation to each other.

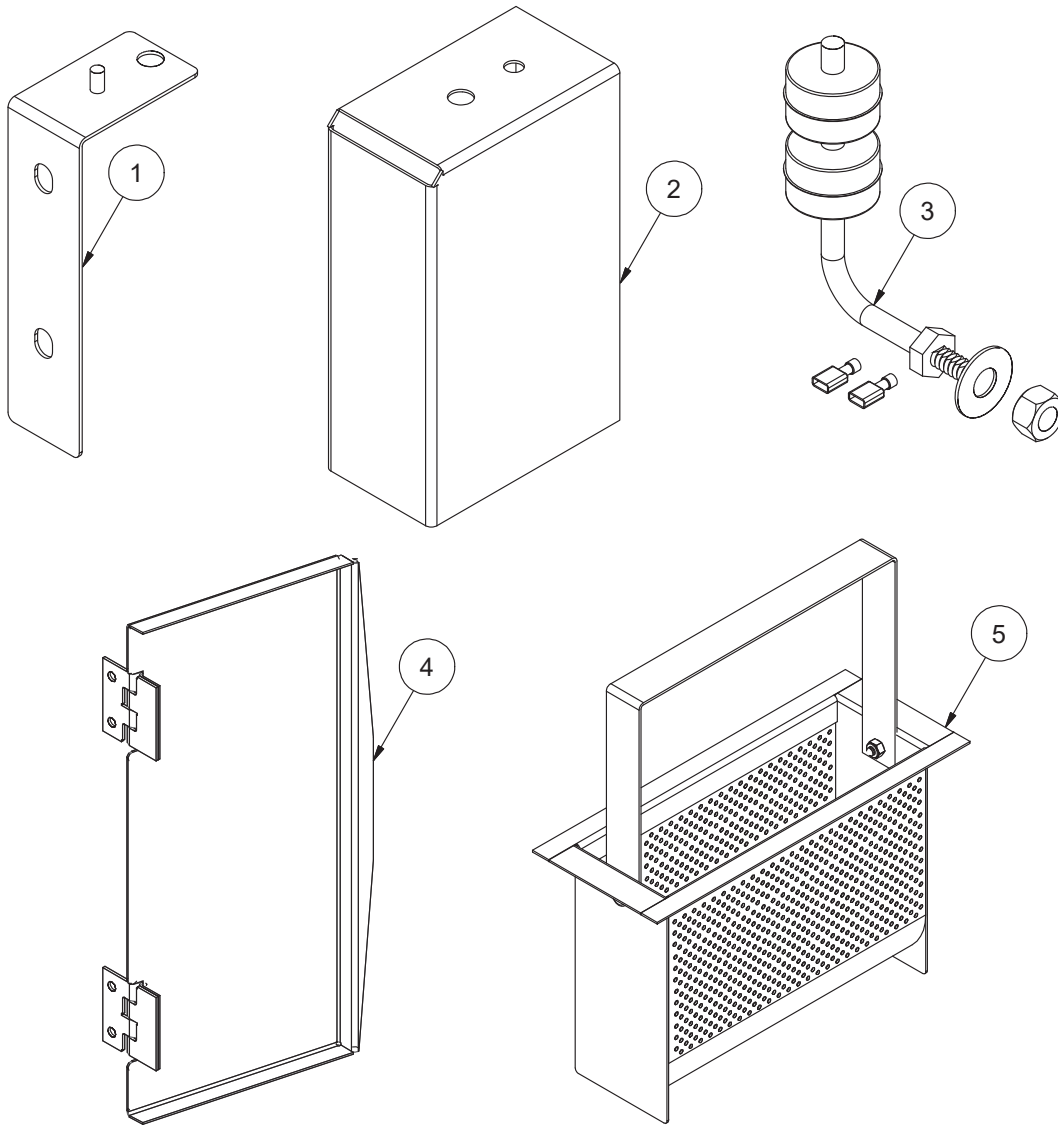

ITEM	QTY	DESCRIPTION	PART NUMBER
1	1	Float Switch Support Bracket Kit*	06401-003-11-77
2	1	Float Switch Cover	05700-021-75-71
3	1	Wash Tank Float Switch Kit* Pre-wash Tank Float Switch Kit*	06401-003-11-75 06401-003-11-76
4	1	Scrap Basket Lid	05700-002-56-55
5	1	Scrap Basket Assembly	06401-011-87-78

* Kit contains part(s) and all hardware.

NOTICE When installing float switch kit, washer goes inside tub and nut goes outside tub.

Parts are not shown to scale with relation to each other.

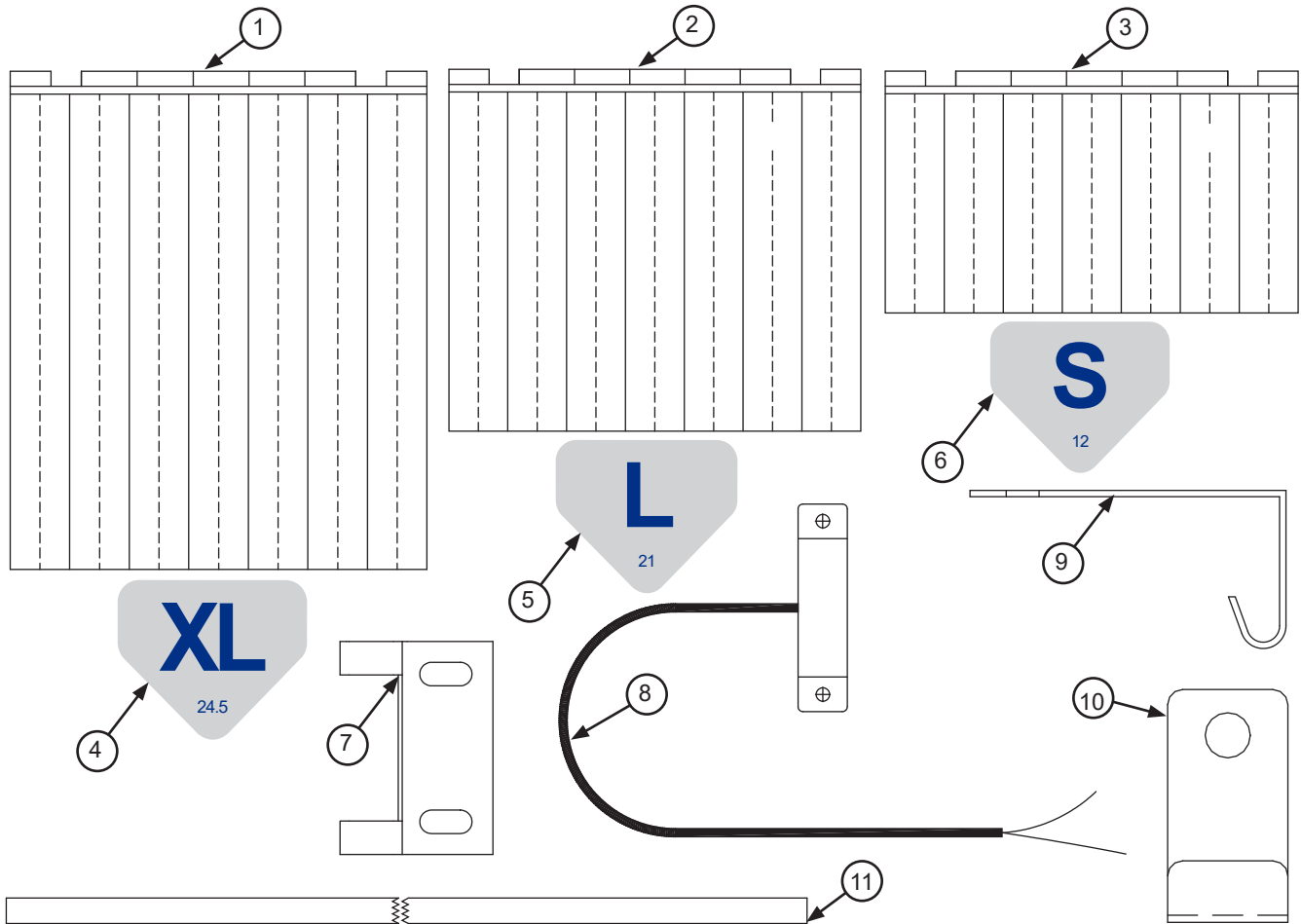

ITEM	QTY	DESCRIPTION	PART NUMBER
1	1	Curtain, XL, 24 1/2" x 20 1/2"	08415-002-47-37
2	1	Curtain, L, 21" x 20 1/2"	08415-131-73-45
3	1	Curtain, S, 12" x 20 1/2"	08415-131-73-44
4	1	Decal, XL Curtain	09905-004-38-08
5	1	Decal, L Curtain	09905-004-38-07
6	1	Decal, S Curtain	09905-004-38-05
7	1	Limit Switch Bracket	05700-021-71-18
8	1	Conveyor Switch Kit*	06401-003-11-79
9	1	Middle Curtain Hook	05700-011-72-65
10	1	Curtain Hook	05700-011-83-54
11	1	Curtain Rod	05700-003-77-52
12	1	Curtain, XL, Side-loader (Not Shown)	08415-003-84-88
13	1	Curtain Rod, Side-loader (Not Shown)	05700-003-84-57

* Kit contains the switch, a terminal, and a wire nut. Cut the cord on the Conveyor Switch to length in the field and install the terminal there.

Parts are not shown to scale with relation to each other.

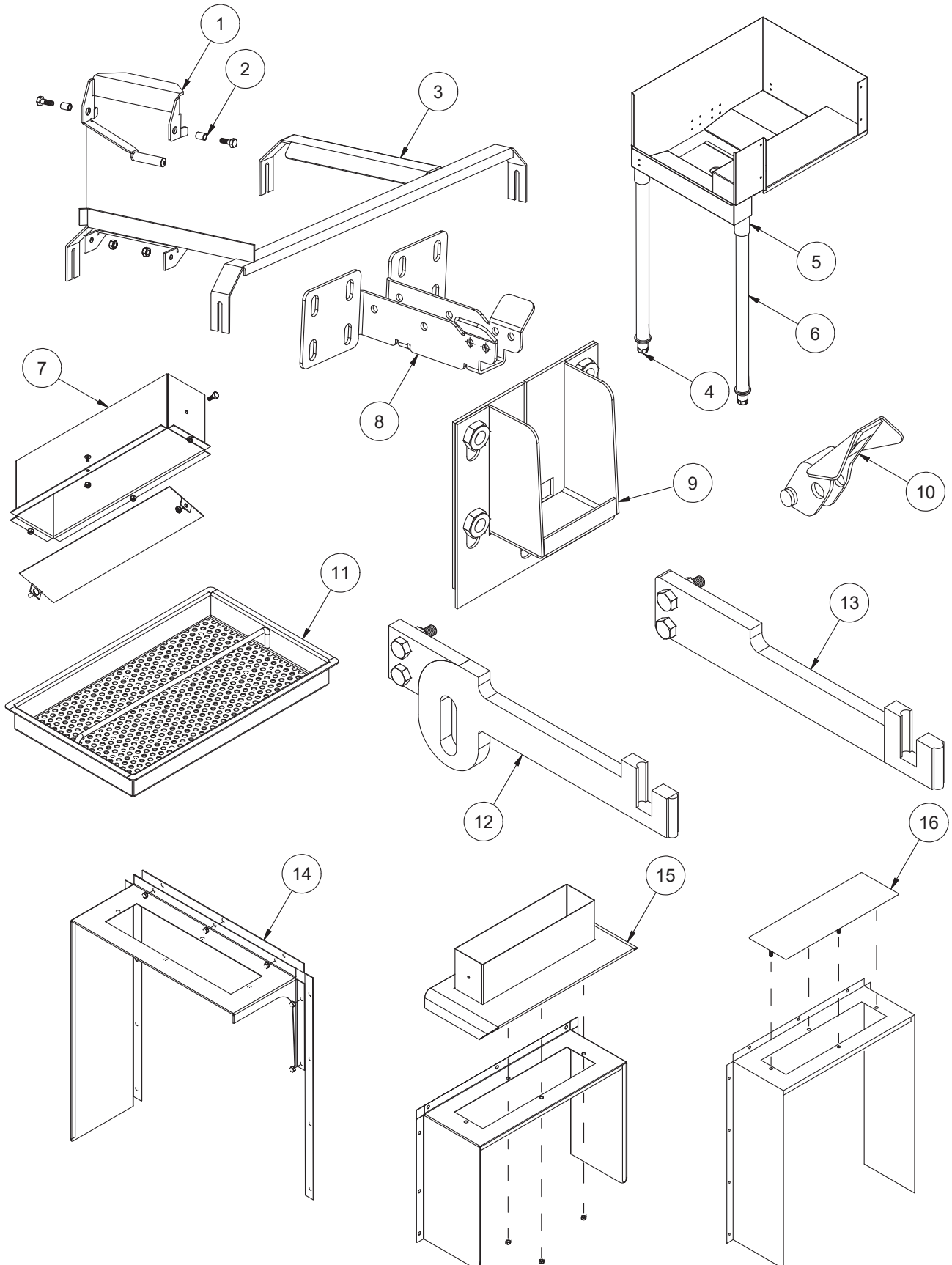

ITEM	QTY	DESCRIPTION	PART NUMBER
1	1	Actuator Switch, Side-loader Actuator Switch Kit*	05700-002-91-12 06401-003-10-64
2	1	Pawl Bar Spacer	05700-011-71-44
3	1	Track, Side-loader (L-R), 23" Track, Side-loader (R-L), 23" Track, Side-loader (L-R), 30" Track, Side-loader(R-L), 30"	05700-031-78-98 05700-031-95-20 05700-003-04-57 05700-003-04-58
4	1	Adjustable Foot, Side-loader	05340-108-01-03
5	1	Leg Socket Kit*	06401-003-09-79
6	1	Leg Support Kit*	06401-003-09-80
7	1	Vent Cowl Assembly for Hooded Side-loader	05700-003-15-66
8	1	Pawl Bar Roller Bracket	05700-031-77-94
9	1	Pawl Bar Gutter Kit*	06401-003-09-95
10	1	Rack Catch	05700-021-86-79
11	1	Front Strainer, Side-loader	05700-021-85-10
12	1	Drive Linkage Kit (L-R)*	06401-003-11-59
13	1	Drive Linkage Kit (R-L)*	06401-003-11-60
14	1	Vent Scoop Option Assembly	05700-002-04-08
15	1	Vent Cowl Cover Kit*	06401-003-10-16
16	1	Vent Cowl Option Assembly for Hooded Side-loader	05700-003-15-66

* Kit contains part(s) and all hardware.

Parts are not shown to scale with relation to each other.

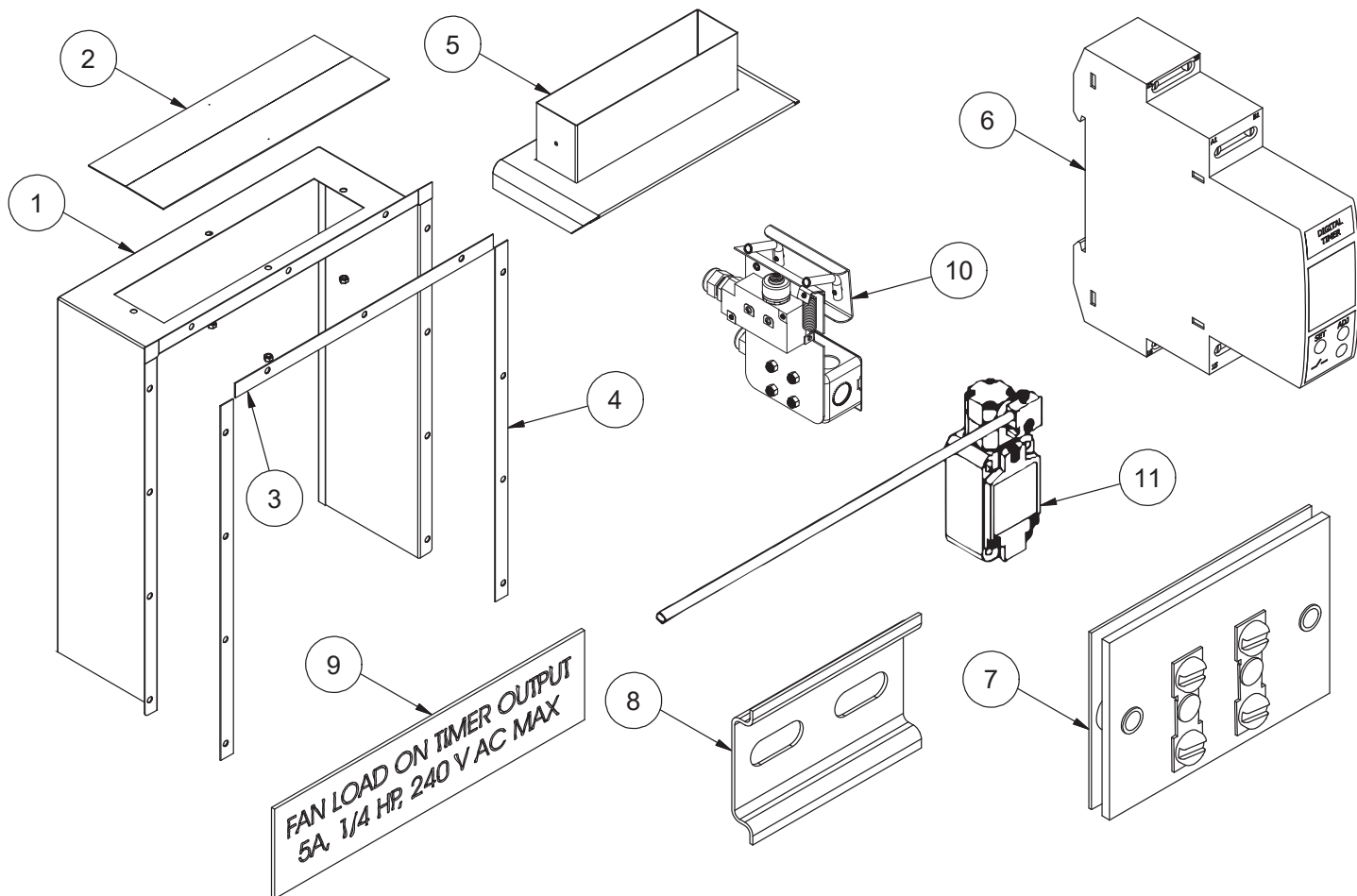

ITEM	QTY	DESCRIPTION	PART NUMBER
1	1	Vent Cowl	05700-041-86-94
2	1	Vent Cowl Cover Vent Cowl Cover Replacement Kit*	05700-011-74-67 06401-003-10-16
3	1	Gasket, Top Vent Cowl	05330-031-83-47
4	1	Gasket, Side Vent Cowl	05330-031-83-48
5	1	Vent Scoop Option	05700-002-04-08
6	1	Delay Timer, Exhaust Fan	05945-004-22-78
7	1	Terminal Board, Exhaust Fan	05940-011-84-41
8	1	Din Rail, Exhaust Fan	05700-002-36-09
9	1	Decal, Exhaust Fan Load	09905-003-32-20
10	1	Striker Plate Limit Switch Complete Assembly	05700-002-62-94
11	1	Whisker Plate Limit Switch Complete Assembly	05700-002-06-83

* Kit contains part(s) and all hardware.

Exhaust Fan Kit
05700-031-90-53

Parts are not shown to scale with relation to each other.

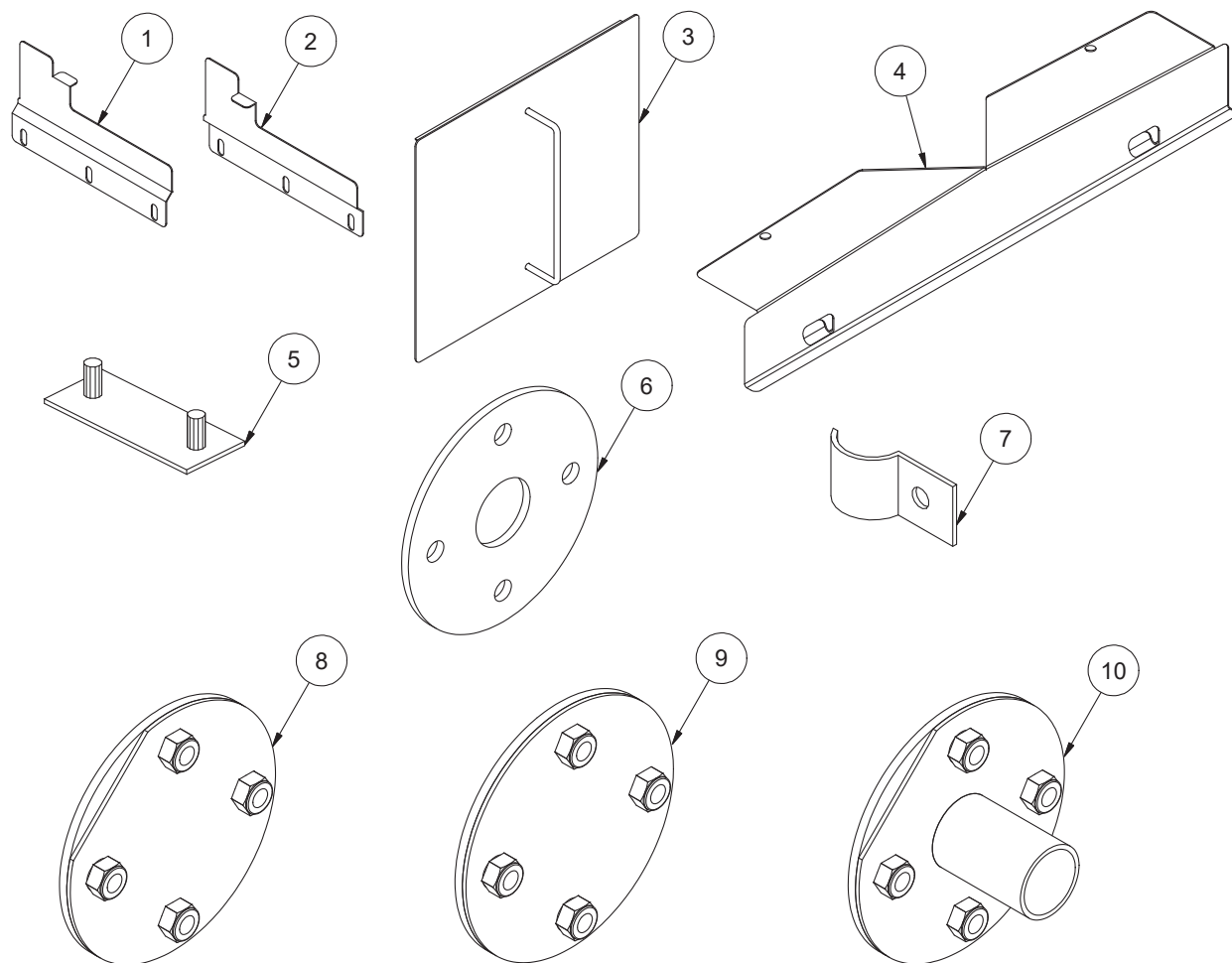

ITEM	QTY	DESCRIPTION	PART NUMBER
1	1	Plate, Left Water Directional	05700-021-79-27
2	1	Plate, Right Water Directional	05700-021-79-23
3	1	Run-off Sheet	05700-021-71-39
4	1	Splash Shield	05700-031-85-16
5	1	Hole Direction Plate Kit*	06401-003-10-00
6	1	Rinse Drain Plate Gasket	05330-011-72-27
7	1	Pipe Clamp	05700-000-35-05
8	1	Rinse Drain Plate Kit*	06401-003-10-07
9	1	Rinse Drain Plug Kit*	06401-003-10-06
10	1	Rinse Drain Weldment Kit*	06401-003-10-05

* Kit contains part(s) and all hardware.

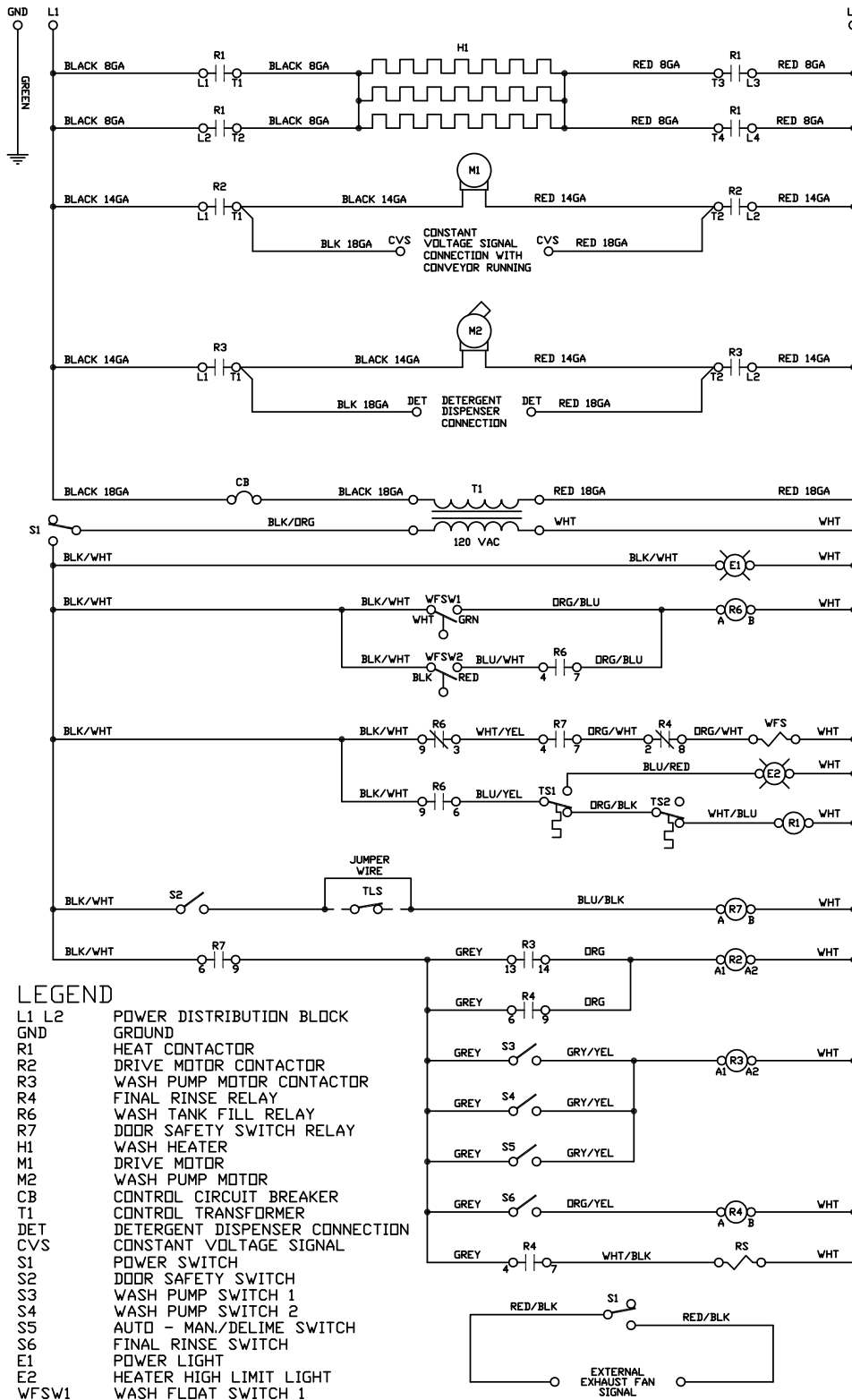

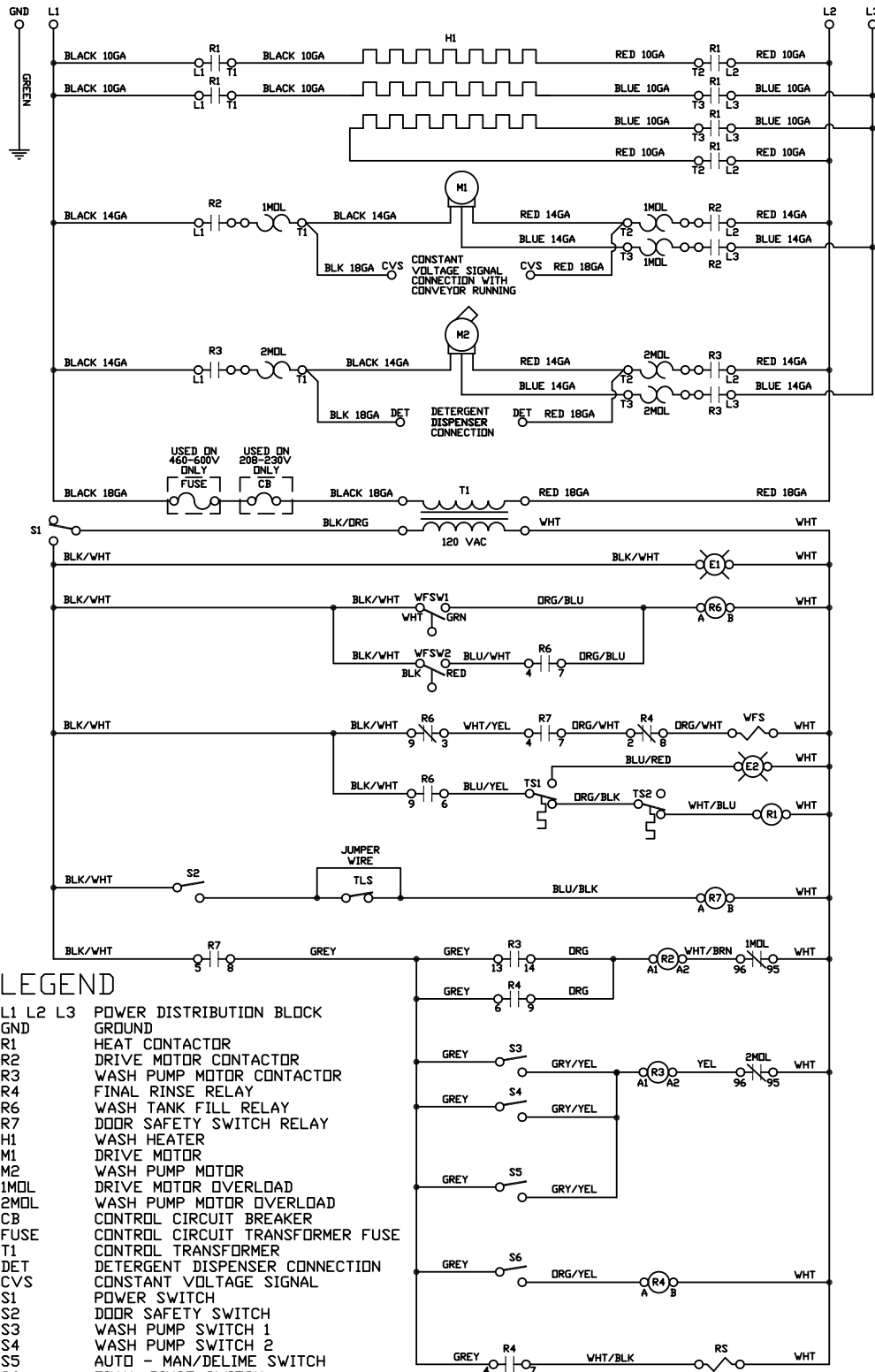

LEGEND

- L1 L2 L3 POWER DISTRIBUTION BLOCK
- GND GROUND
- R1 HEAT CONTACTOR
- R2 DRIVE MOTOR CONTACTOR
- R3 WASH PUMP MOTOR CONTACTOR
- R4 FINAL RINSE RELAY
- R6 WASH TANK FILL RELAY
- R7 DOOR SAFETY SWITCH
- H1 WASH HEATER
- M1 DRIVE MOTOR
- M2 WASH PUMP MOTOR
- 1MDL DRIVE MOTOR OVERLOAD
- 2MDL WASH PUMP MOTOR OVERLOAD
- CB CONTROL CIRCUIT BREAKER
- FUSE CONTROL CIRCUIT TRANSFORMER FUSE
- T1 CONTROL TRANSFORMER
- DET DETERGENT DISPENSER CONNECTION
- CVS CONSTANT VOLTAGE SIGNAL
- S1 POWER SWITCH
- S2 DOOR SAFETY SWITCH
- S3 WASH PUMP SWITCH 1
- S4 WASH PUMP SWITCH 2
- S5 AUTO - MAN/DELIME SWITCH
- S6 FINAL RINSE SWITCH
- E1 POWER LIGHT
- E2 HEATER HIGH LIMIT LIGHT
- WFSW1 WASH FLDAT SWITCH 1
- WFSW2 WASH FLDAT SWITCH 2
- TS1 HEATER HIGH LIMIT THERMOSTAT
- TS2 WASH REGULATING THERMOSTAT
- TLS TABLE LIMIT SWITCH (OPTIONAL)
- WFS WASH FILL SOLENOID
- RS FINAL RINSE SOLENOID

09905-003-60-99 C

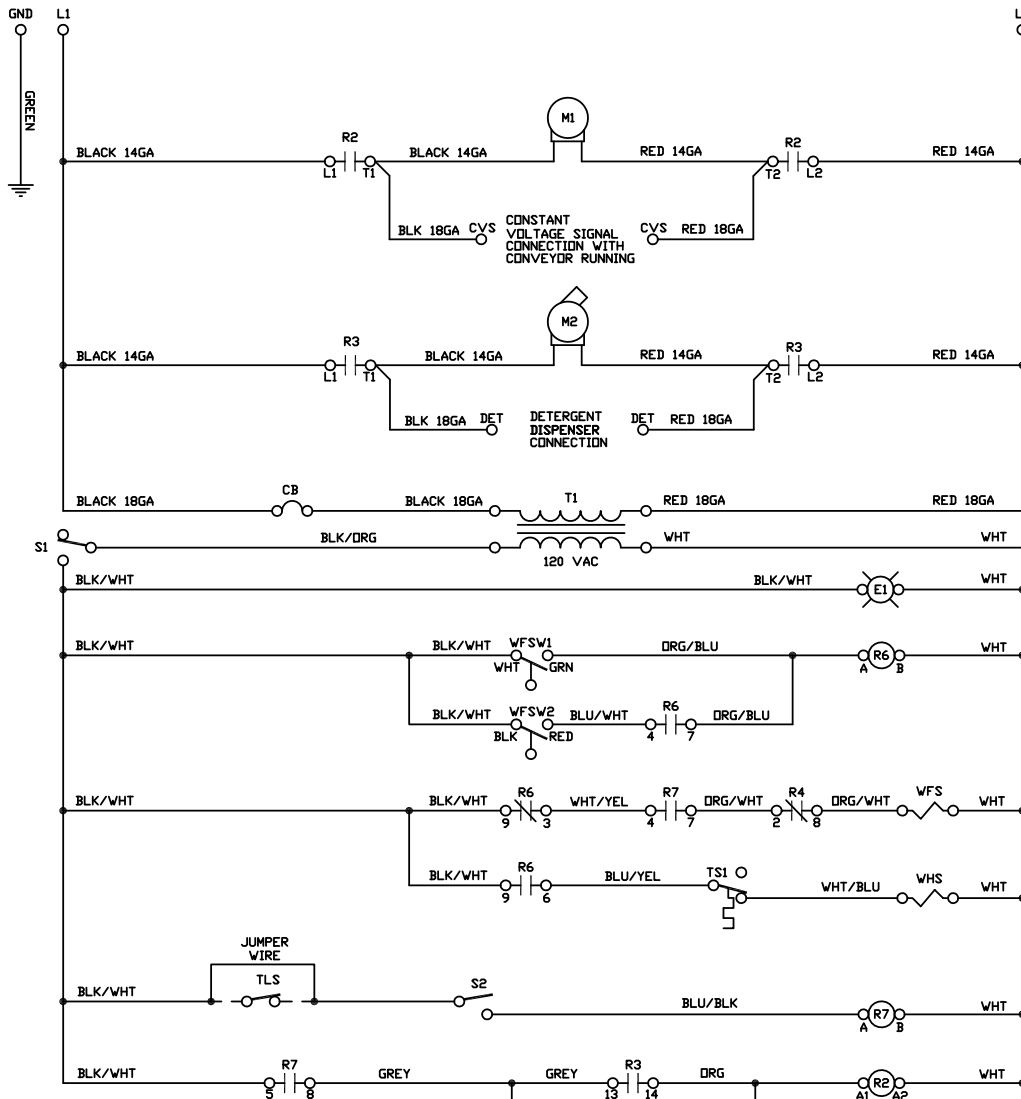

LEGEND

- L1 L2 L3 POWER DISTRIBUTION BLOCK
- GND GROUND
- R2 DRIVE MOTOR CONTACTOR
- R3 WASH PUMP MOTOR CONTACTOR
- R4 FINAL RINSE RELAY
- R6 WASH TANK FILL RELAY
- R7 DOOR SAFETY SWITCH RELAY
- M1 DRIVE MOTOR
- M2 WASH PUMP MOTOR
- CB CONTROL CIRCUIT BREAKER
- T1 CONTROL TRANSFORMER
- DET DETERGENT DISPENSER CONNECTION
- CVS CONSTANT VOLTAGE SIGNAL
- S1 POWER SWITCH
- S2 DOOR SAFETY SWITCH
- S3 WASH PUMP SWITCH 1
- S4 WASH PUMP SWITCH 2
- S5 AUTO - MAN/DELIME SWITCH
- S6 FINAL RINSE SWITCH
- E1 POWER LIGHT
- WFSW1 WASH FLOAT SWITCH 1
- WFSW2 WASH FLOAT SWITCH 2
- TS1 WASH REGULATING THERMOSTAT
- TLS TABLE LIMIT SWITCH (OPTIONAL)
- WFS WASH FILL SOLENOID
- WHS WASH HEAT SOLENOID
- RS FINAL RINSE SOLENOID

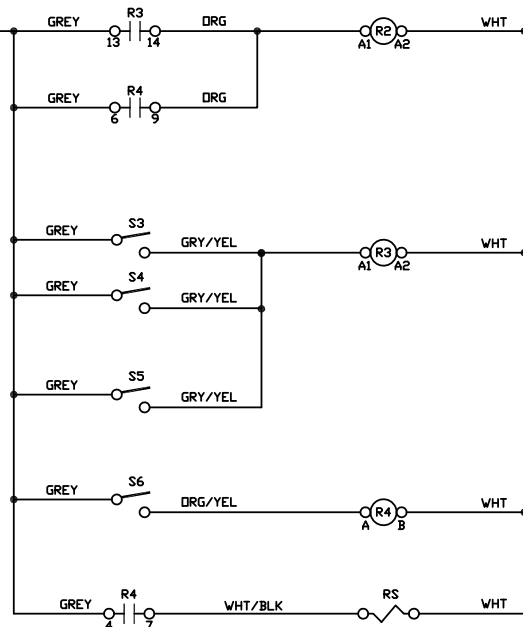

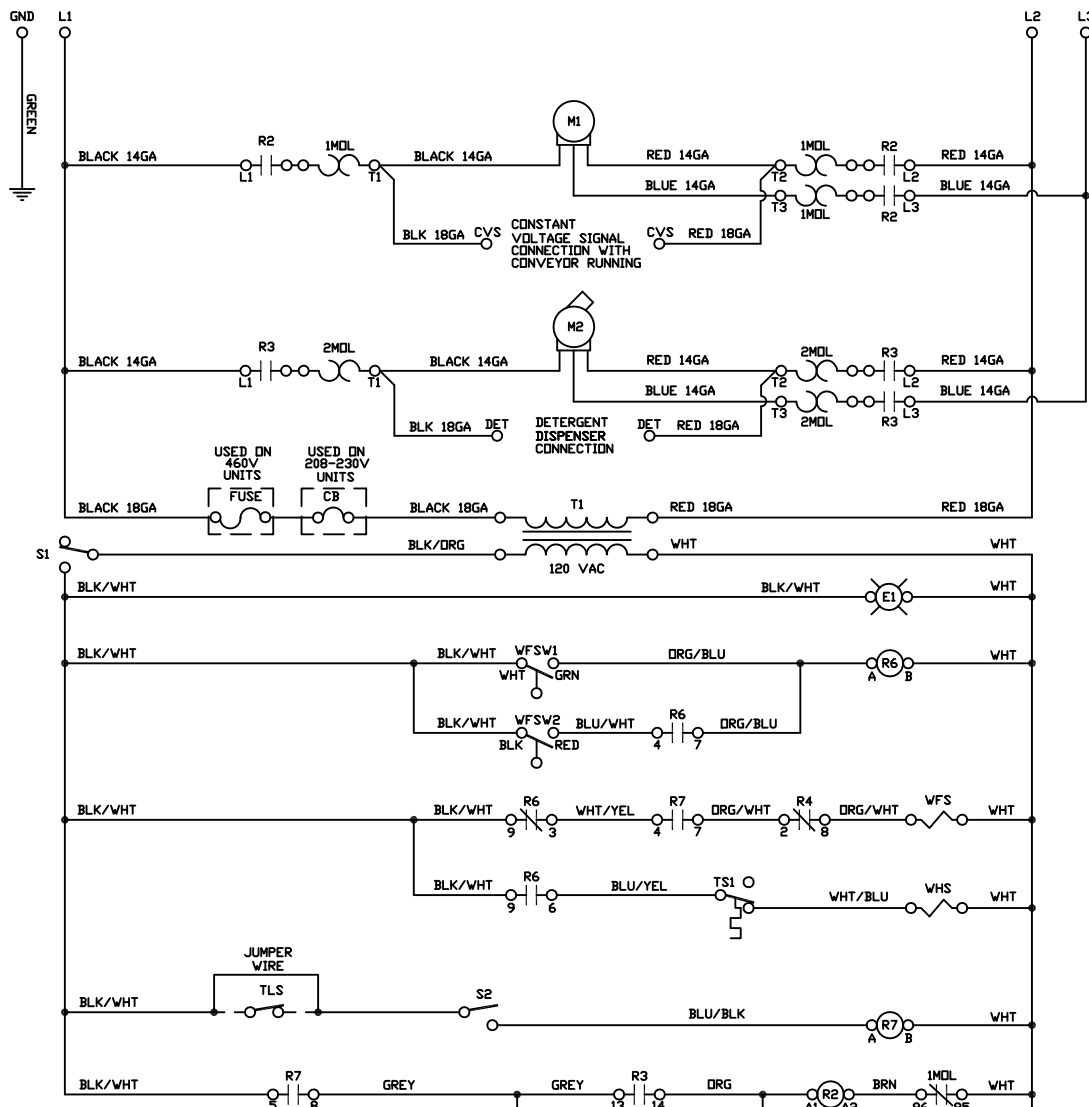

LEGEND

- L1 L2 L3 POWER DISTRIBUTION BLOCK
- GND GROUND
- R2 DRIVE MOTOR CONTACTOR
- R3 WASH PUMP MOTOR CONTACTOR
- R4 FINAL RINSE RELAY
- R6 WASH TANK FILL RELAY
- R7 DOOR SAFETY SWITCH RELAY
- M1 DRIVE MOTOR
- M2 WASH PUMP MOTOR
- 1MDL DRIVE MOTOR OVERLOAD
- 2MDL WASH PUMP MOTOR OVERLOAD
- CB CONTROL CIRCUIT BREAKER
- FUSE CONTROL CIRCUIT FUSE
- T1 CONTROL TRANSFORMER
- DET DETERGENT DISPENSER CONNECTION
- CVS CONSTANT VOLTAGE SIGNAL
- S1 POWER SWITCH
- S2 DOOR SAFETY SWITCH
- S3 WASH PUMP SWITCH 1
- S4 WASH PUMP SWITCH 2
- S5 AUTO - MAN/DELIME SWITCH
- S6 FINAL RINSE SWITCH
- E1 POWER LIGHT
- WFSW1 WASH FLOAT SWITCH 1
- WFSW2 WASH FLOAT SWITCH 2
- TS1 WASH REGULATING THERMOSTAT
- TLS TABLE LIMIT SWITCH (OPTIONAL)
- WFS WASH FILL SOLENOID
- WHS WASH HEAT SOLENOID
- RS FINAL RINSE SOLENOID

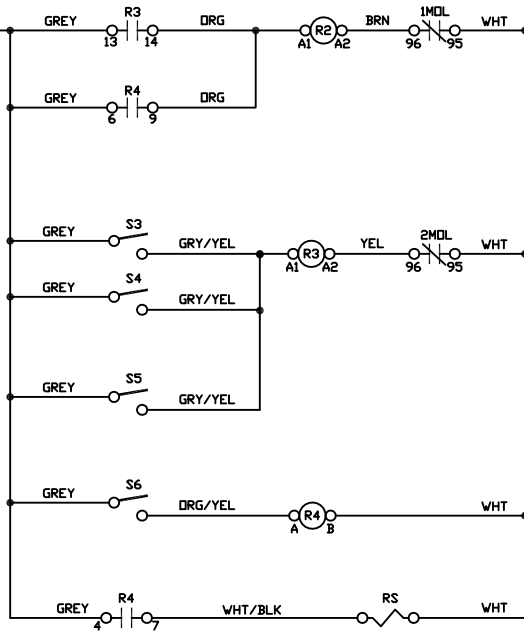

09905-003-61-78

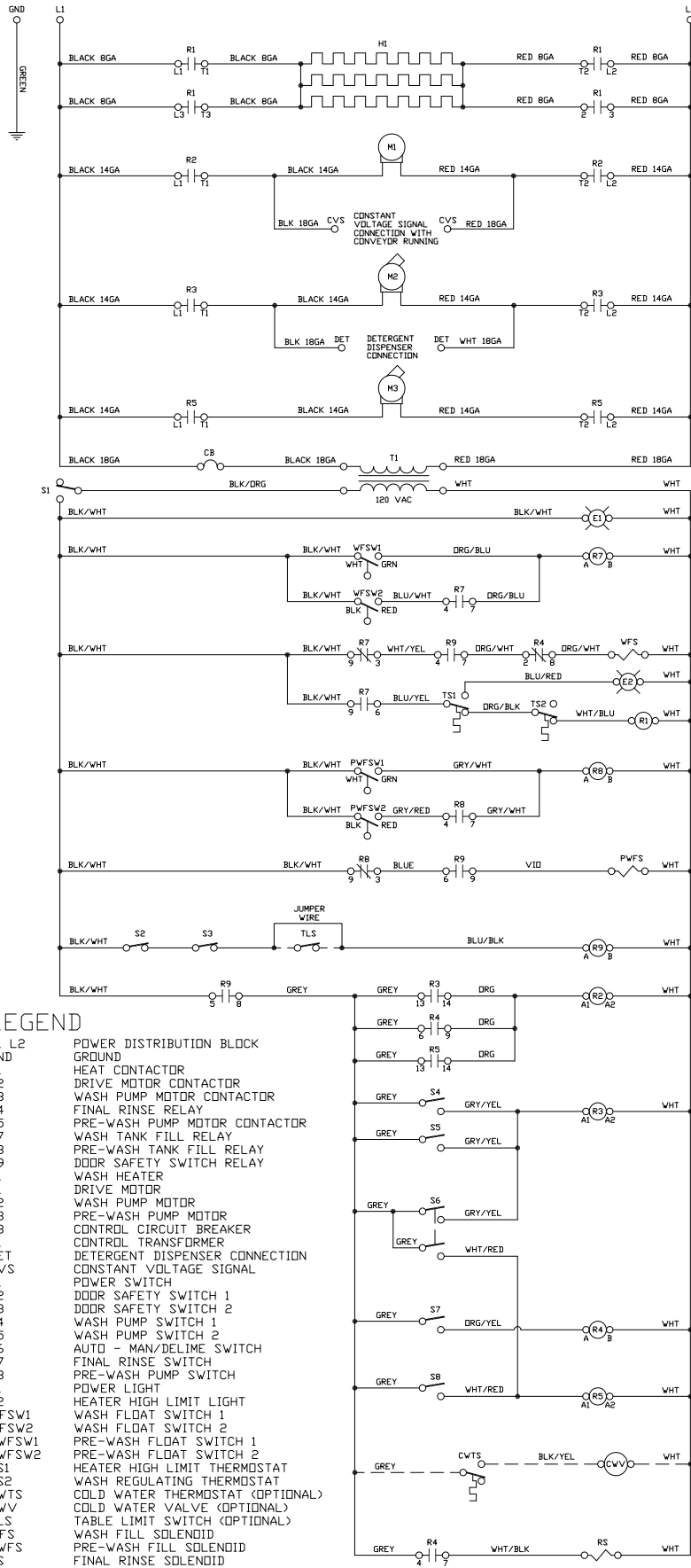

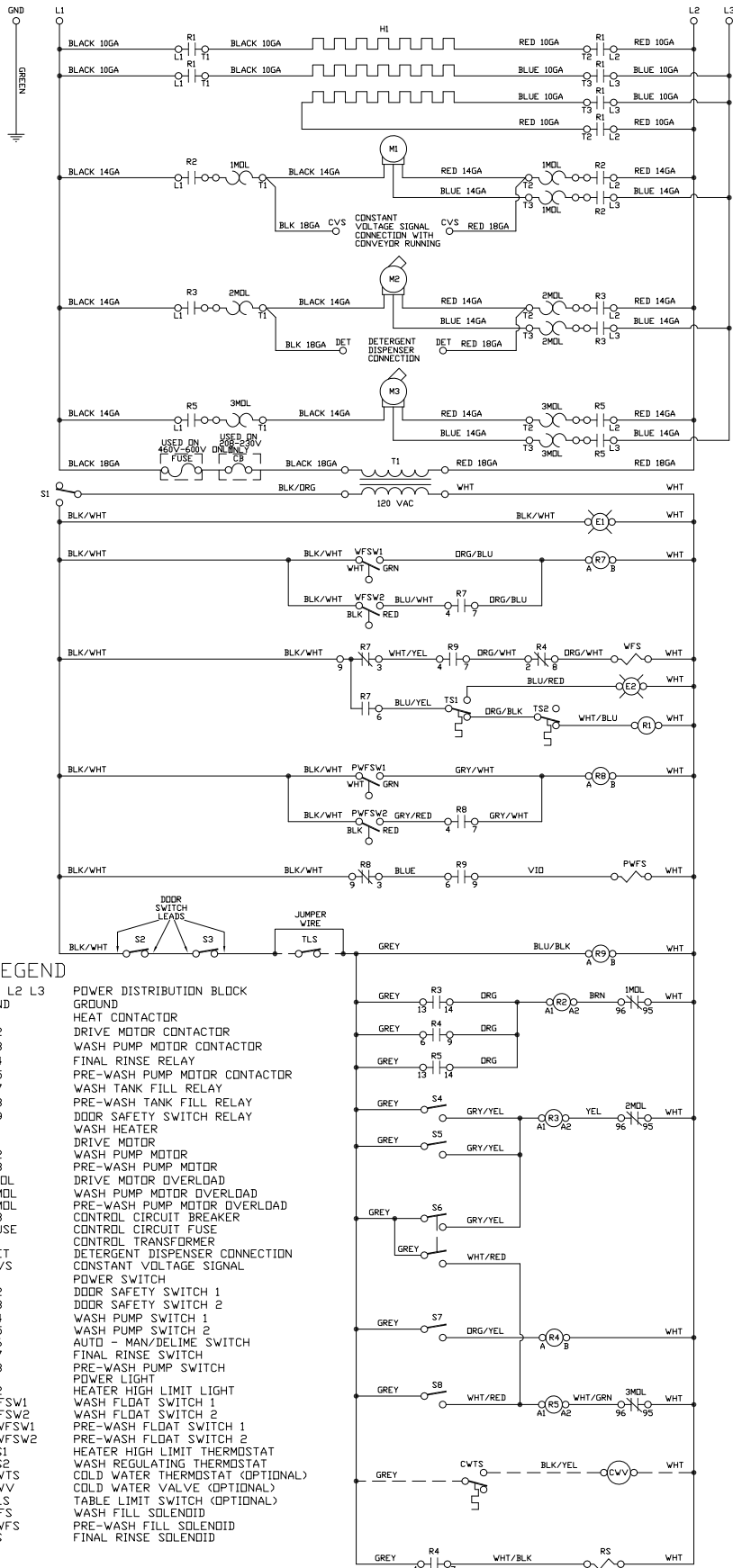

- LEGEND**
- L1 L2 L3 POWER DISTRIBUTION BLOCK
 - GND GROUND
 - R1 HEAT CONTACTOR
 - R2 DRIVE MOTOR CONTACTOR
 - R3 WASH PUMP MOTOR CONTACTOR
 - R4 FINAL RINSE RELAY
 - R5 PRE-WASH PUMP MOTOR CONTACTOR
 - R7 WASH TANK FILL RELAY
 - R8 PRE-WASH TANK FILL RELAY
 - R9 DDOR SAFETY SWITCH RELAY
 - H1 WASH HEATER
 - M1 DRIVE MOTOR
 - M2 WASH PUMP MOTOR
 - M3 PRE-WASH PUMP MOTOR
 - 1MDL DRIVE MOTOR OVERLOAD
 - 2MDL WASH PUMP MOTOR OVERLOAD
 - 3MDL PRE-WASH PUMP MOTOR OVERLOAD
 - CB CONTROL CIRCUIT BREAKER
 - FUSE CONTROL CIRCUIT FUSE
 - T1 CONTROL TRANSFORMER
 - DET DETERGENT DISPENSER CONNECTION
 - CVS CONSTANT VOLTAGE SIGNAL
 - S1 POWER SWITCH
 - S2 DDOR SAFETY SWITCH 1
 - S3 DDOR SAFETY SWITCH 2
 - S4 WASH PUMP SWITCH 1
 - S5 WASH PUMP SWITCH 2
 - S6 AUTO - MAN/DELTIME SWITCH
 - S7 FINAL RINSE SWITCH
 - S8 PRE-WASH PUMP SWITCH
 - E1 POWER LIGHT
 - E2 HEATER HIGH LIMIT LIGHT
 - WFSW1 WASH FLOAT SWITCH 1
 - WFSW2 WASH FLOAT SWITCH 2
 - PWFSW1 PRE-WASH FLDT SWITCH 1
 - PWFSW2 PRE-WASH FLDT SWITCH 2
 - TS1 HEATER HIGH LIMIT THERMOSTAT
 - TS2 WASH REGULATING THERMOSTAT
 - CWTS COLD WATER THERMOSTAT (OPTIONAL)
 - CWV COLD WATER VALVE (OPTIONAL)
 - TLS TABLE LIMIT SWITCH (OPTIONAL)
 - WFS WASH FILL SOLENOID
 - PWFS PRE-WASH FILL SOLENOID
 - RS FINAL RINSE SOLENOID

09905-003-63-75 REVISION D

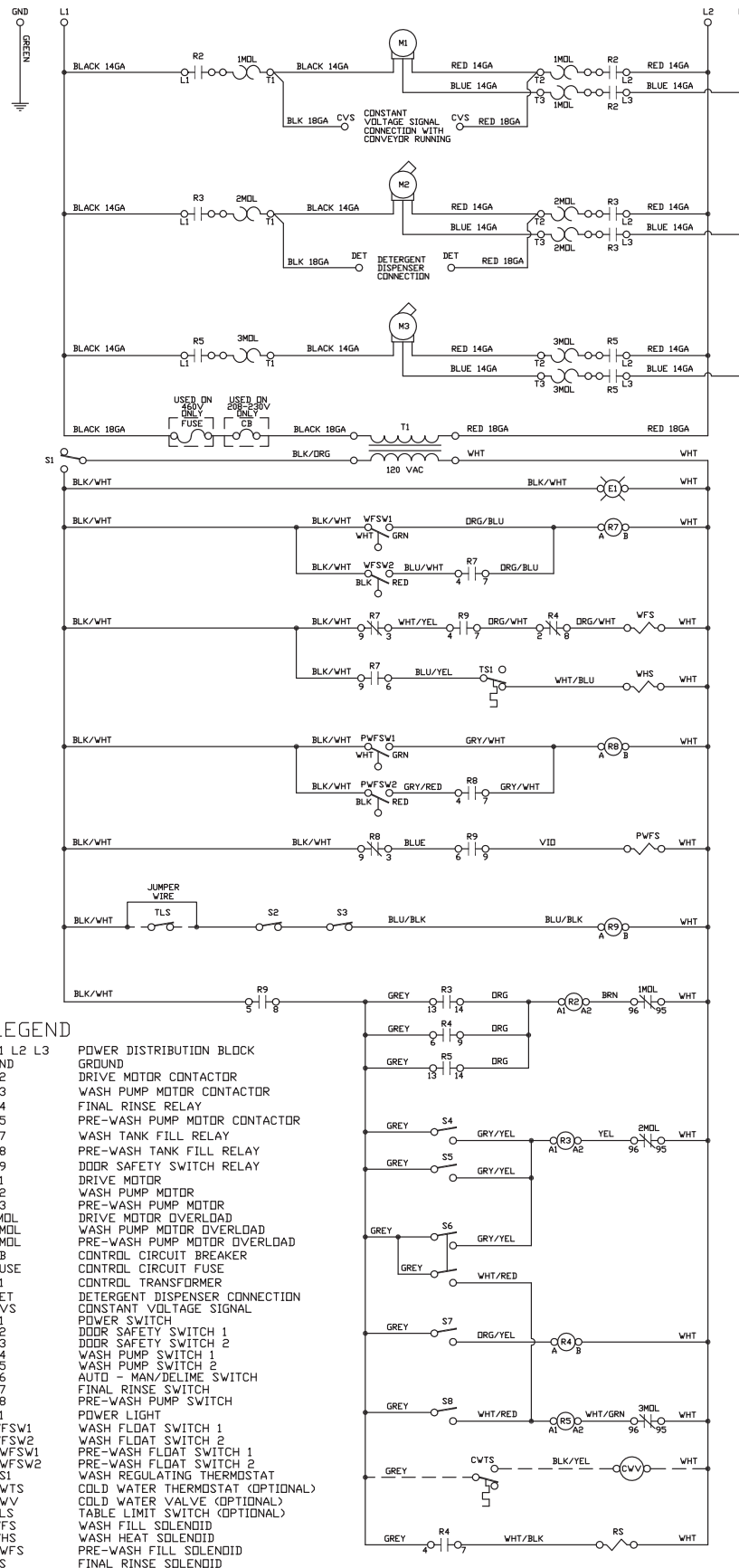

09905-003-65-07

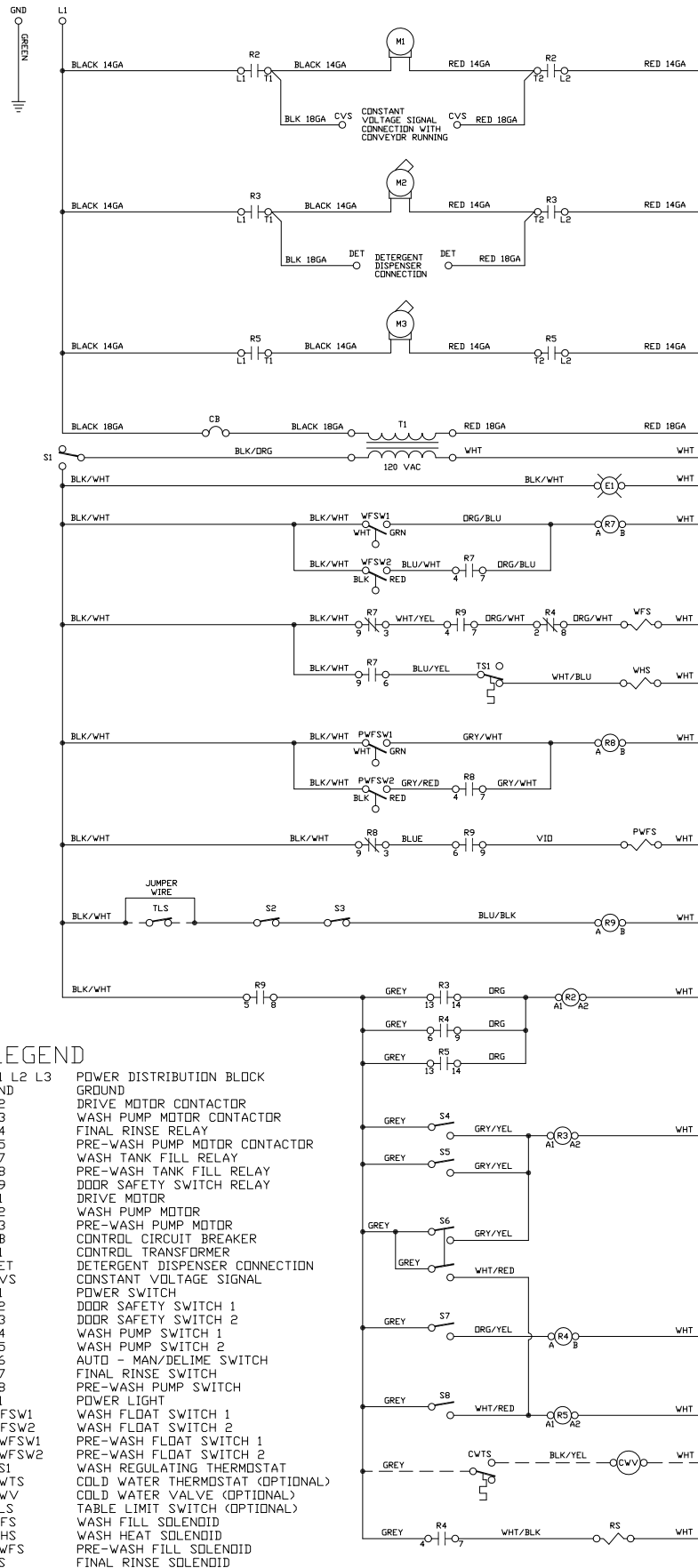

LEGEND

- L1 L2 L3 POWER DISTRIBUTION BLOCK
- GND GROUND
- R2 DRIVE MOTOR CONTACTOR
- R3 WASH PUMP MOTOR CONTACTOR
- R4 FINAL RINSE RELAY
- R5 PRE-WASH PUMP MOTOR CONTACTOR
- R7 WASH TANK FILL RELAY
- R8 PRE-WASH TANK FILL RELAY
- R9 DOOR SAFETY SWITCH RELAY
- M1 DRIVE MOTOR
- M2 WASH PUMP MOTOR
- M3 PRE-WASH PUMP MOTOR
- CB CONTROL CIRCUIT BREAKER
- T1 CONTROL TRANSFORMER
- DET DETERGENT DISPENSER CONNECTION
- CVS CONSTANT VOLTAGE SIGNAL
- S1 POWER SWITCH
- S2 DOOR SAFETY SWITCH 1
- S3 DOOR SAFETY SWITCH 2
- S4 WASH PUMP SWITCH 1
- S5 WASH PUMP SWITCH 2
- S6 AUTO - MAN/DELIME SWITCH
- S7 FINAL RINSE SWITCH
- S8 PRE-WASH PUMP SWITCH
- E1 POWER LIGHT
- WFSW1 WASH FLOAT SWITCH 1
- WFSW2 WASH FLOAT SWITCH 2
- PWFSW1 PRE-WASH FLOAT SWITCH 1
- PWFSW2 PRE-WASH FLOAT SWITCH 2
- TS1 WASH REGULATING THERMOSTAT
- CWTS COLD WATER THERMOSTAT (OPTIONAL)
- CWV COLD WATER VALVE (OPTIONAL)
- TLS TABLE LIMIT SWITCH (OPTIONAL)
- WFS WASH FILL SOLENOID
- WHS WASH HEAT SOLENOID
- PWFS PRE-WASH FILL SOLENOID
- RS FINAL RINSE SOLENOID

09905-003-65-08

CONVEYOR SIDE LOADER

44, 54, 64 INCH CONVEYORS

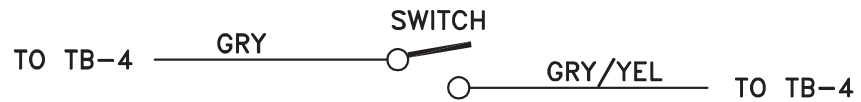

ALL CONVEYORS WITH PRE-WASH

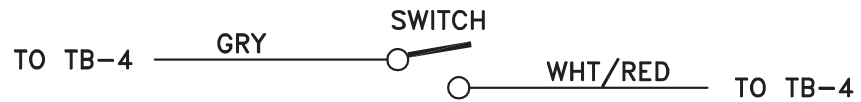

9905-002-56-84a

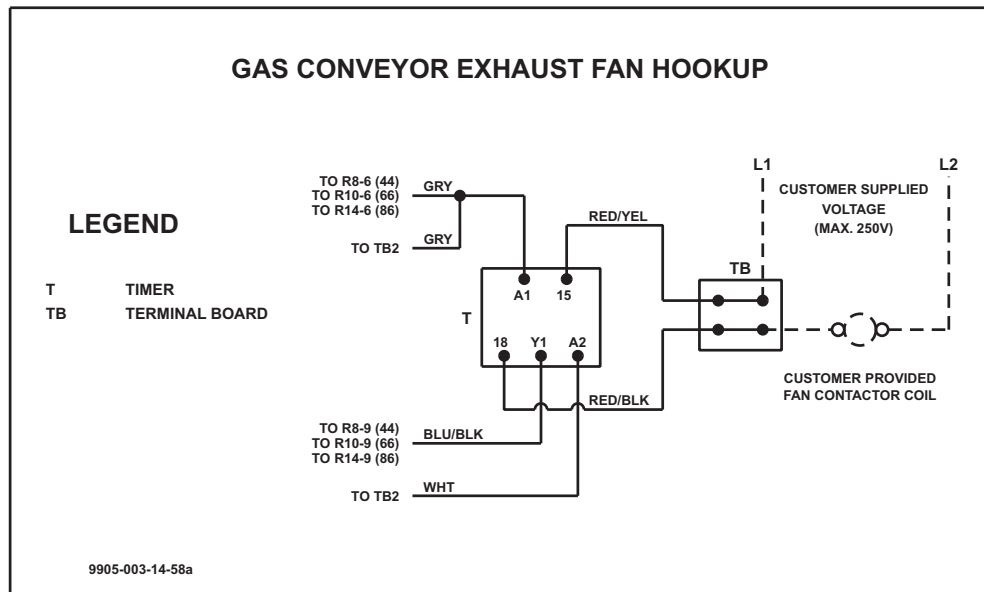
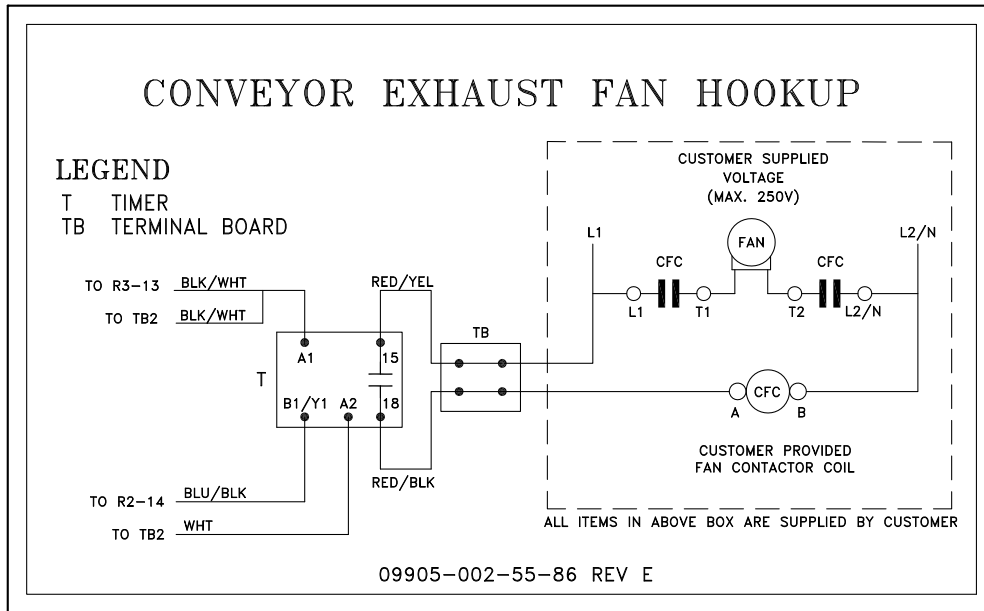



Jackson WWS, Inc. • 6209 N. US Hwy 25E • Gray, KY 40734 USA
1.888.800.5672 • www.jacksonwws.com