



IRTC014

## NEW AND IMPROVED!

### TABLE MOUNT CAN OPENER

14" table mounted can opener, heavy duty. This product is made of heavy duty cast iron. It can open up to 10" tall cans. Designed with easily replaceable blade. Essential for any commercial kitchen that serves canned food. Commercial grade quality, made to endure the toughest condition in any kitchen.

ITEM	DESCRIPTION	U/M	WEIGHT GROSS lbs	INNER PACK	MASTER PACK	CU.FT.
IRTC014	Heavy Duty Table Mounted Can Opener	EACH	55.12	1	6	3.06

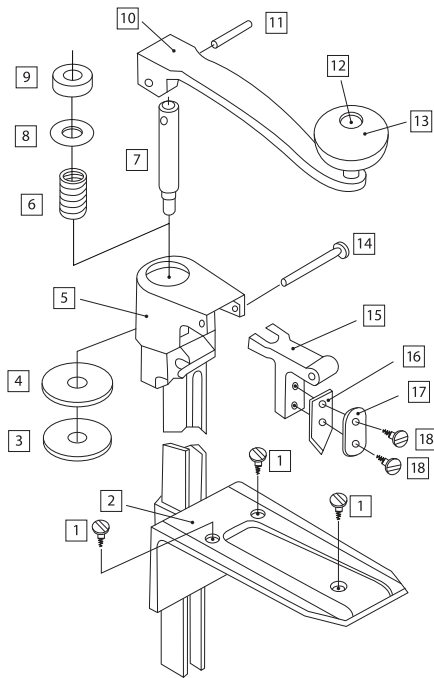

### PARTS

ITEM	DESCRIPTION	U/M
1 IRTC014-01	Screw for Base, Set of 3	SET
2 IRTC014-02	Base	EACH
3 IRTC014-03	Gear	EACH
4 IRTC014-04	Gear Spear	EACH
5 IRTC014-05	Body	EACH
6 IRTC014-06	Spring	EACH
7 IRTC014-07	Arbor	EACH
8 IRTC014-08	Spring Washer	EACH
9 IRTC014-09	Bushing	EACH
10 IRTC014-10	Handle	EACH
11 IRTC014-11	Handle Pin	EACH
12 IRTC014-12	Knob Privet	EACH
13 IRTC014-13	Knob	EACH
14 IRTC014-14	Knife Holder Pin	EACH
15 IRTC014-15	Knife Holder	EACH
16 IRTC014-16	Knife	EACH
17 IRTC014-17	Knife Spear	EACH
18 IRTC014-18	Screw for Knife, Set of 2	SET

### CAN / BOTTLE OPENER

Features a built-in bottle cap remover. Easy to clean.



OW110



SLBO106

ITEM	DESCRIPTION	U/M	WEIGHT GROSS lbs	INNER PACK	MASTER PACK	CU.FT.
OW110	Rotary Can Opener	EACH	44.53	12	96	1.72
SLBO106	Punch Can Opener	EACH	38.14	12	144	0.23