



PROJECT NAME: \_\_\_\_\_

LOCATION: \_\_\_\_\_

ITEM: \_\_\_\_\_ QTY: \_\_\_\_\_

MODEL: \_\_\_\_\_



## SR-4B-36G-60 RANGE COMBO WITH MANUAL GRIDDLE

Sierra range combo with manual griddle 100% manufactured from raw materials to provide the best cooking experience, a high standard of quality, and the highest durability in its class to meet the needs of a commercial kitchen.

The Sierra range combo SR-4B-36G-60 commercial range is great for cooking with several pots or pans simultaneously. Cast iron grates on the burners transmit heat efficiently to the pan from the burner. Beneath the burners is a crumb tray that catches and contains loose food matter.

SR-4B-36G-60

Unit shown with optional casters. Unit ships with legs as standard



## STANDARD FEATURES

### GRIDDLE

- Stainless steel front and sides.
- 3" Splash guards.
- 3/4" (19.05mm) thick polished carbon steel working griddle plate.
- Fully welded griddle plate.
- Enameled griddle burner placed every 12", providing uniformity when operating.
- Accessible pilots through front panel.
- Easily removable stainless steel griddle grease trap.

### RANGE

- Stainless steel front and sides.
- 12" x 12" cast iron top grates designed for easy movement of pots across top sections.
- Deflectors to direct waste to crumb/drip pan.
- Landing ledge, promoting safety and great functionality.
- Orange paint injected aluminum knobs providing for better toughness and durability.
- Easily removable stainless steel crumb/drip pan.

### OVEN

- Oven with snap action thermostat from 210°F to 550°F and 100% safety shut off.
- 26 1/2" Standard bakery depth on all ovens.
- Double-sided enamel oven cavity (Interior top, bottom, and sides).
- Heavy-duty wire oven rack – 1/8" diameter.
- The standard oven has 3 shelf positions and 1 rack.
- Counterweight balanced doors.
- Units are shipped ready for natural gas (NG). A propane gas (LP) conversion kit and NG/LP regulator is supplied with the unit.

## ACCESSORIES/OPTIONAL

- (6) 6" swivel casters with front locking brakes.
- Additional oven rack.

SR4B36G6005172022



www.mvpgroupcorp.com



3560 NW 56th Street  
Fort Lauderdale, FL 33309  
Tel.: 786.600.4687 / Toll Free: 844.218.8477  
Fax.: 786.661.4100



5659 Royalmount Avenue  
Montreal, Qc, Canada H4P 2P9  
Tel.: 514.737.9701 / Toll Free: 888.275.4538  
Fax.: 514.342.3854 / Toll Free: 877.453.8832

sales@mvpgroupcorp.com

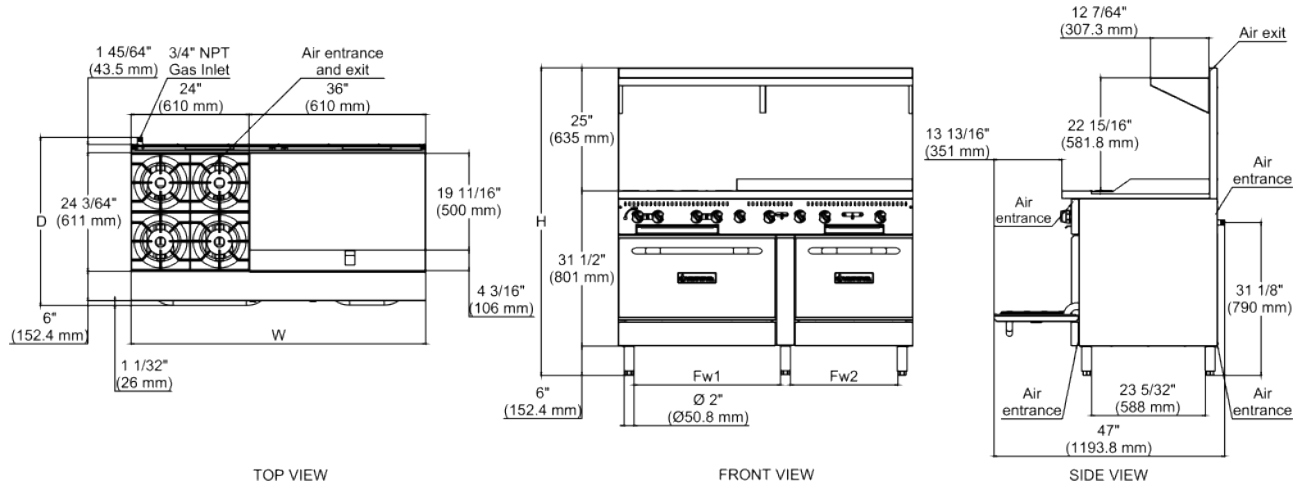

## SPECIFICATIONS

| Models       | Exterior Product Dimensions & Weight |                 |                        |                        |                       |                       | Shipping Crate Dimensions & Weight |                        |                      |                        | Oven - Inside       |  |                     |                       |
|--------------|--------------------------------------|-----------------|------------------------|------------------------|-----------------------|-----------------------|------------------------------------|------------------------|----------------------|------------------------|---------------------|--|---------------------|-----------------------|
|              | Width (W)                            | Depth (D)       | Height (H)             |                        | Fw                    |                       | Weight                             | Width                  | Depth                | Height                 | Weight              | Width                                      | Depth               | Height                |
|              |                                      |                 | P.B                    | P.S                    | Fw1                   | Fw2                   |                                    |                        |                      |                        |                     |  |                     |                       |
| SR-4B-36G-60 | 60"<br>(1525 mm)                     | 35"<br>(889 mm) | 41 17/64"<br>(1048 mm) | 62 33/64"<br>(1588 mm) | 17 19/32"<br>(447 mm) | 29 39/64"<br>(752 mm) | 662 lb<br>(300 kg)                 | 64 61/64"<br>(1650 mm) | 39 1/64"<br>(991 mm) | 45 43/64"<br>(1160 mm) | 1085 lb<br>(492 kg) | 18 57/64" – 26 31/32"<br>(480 mm – 685 mm) | 26 1/2"<br>(673 mm) | 15 23/64"<br>(390 mm) |

## UTILITY INFORMATION

| GAS SUPPLY   |             |         |         |             |             |                   |  |
|--------------|-------------|---------|---------|-------------|-------------|-------------------|--|
| Models       | Burners     | Propane |         | Natural     |             | Manifold Pressure |  |
|              |             | BTU/h   | BTU/h   | Natural Gas | Propane Gas |                   |  |
| SR-4B-36G-60 | Griddle 36" | 3       | 90,000  | 90,000      | 4" W.C      | 10" W.C           |  |
|              | Oven 36"    | 1       | 33,000  | 35,000      |             |                   |  |
|              | Range 24"   | 4       | 100,000 | 100,000     |             |                   |  |
|              | Oven 24"    | 1       | 27,000  | 30,000      |             |                   |  |

- Manifold pressure is 4" W.C (natural gas) or 10" W.C (propane gas).
- 3/4" NPT rear gas connection and pressure regulator for both natural gas and propane.
- Check the altitude specifications above 2,000 ft.

\* NOTE: In line with its policy to continually improve its product, Sierra Range reserves the right to change materials and specifications without notice.

## INSTALLATION INSTRUCTIONS

A pressure regulator sized for this unit is included. The gas line connecting to the range must be 3/4" or larger. If flexible connectors are used, the inside diameter must be 3/4" or larger. An adequate ventilation system is required for commercial cooking equipment. Information may be obtained by writing to the National Fire Protection Association, 1 Batterymarch Park, Quincy, MA 02269, www.NFPA.org. When writing, refer to NFPA No. 96.4. These units are manufactured for installation in accordance with ANSZ223.1A (latest edition), National Fuel Gas Code. Copies may be obtained from The American Gas Association, 400 N Capitol St. NW, Washington, DC 20001, www.AGA.org.

**Warranty:** 12 months parts & labor. See Sierra Range Price List for full details.

**Gas Connection:** 3/4" NPT on the right hand rear of the appliance. The pressure regulator (supplied) is to be connected here by the installer.

**Gas pressure:** 4" W.C. - Natural Gas | 10" W.C. - Propane.

**Combustible Clearances:** For use in non-combustible locations | Non-combustible Clearances: 0 inches sides, 0 inches rear Specify type of gas and altitude, if over 2,000 feet, when ordering.

**SIERRA RANGE** is a registered trademark of **MVP Group**.

Due to continuing product development, to ensure best possible performance, the specifications are subject to change without prior notice.