



# BEVERAGE-AIR

Project: _____	AIA#
Item: _____	
Location: _____	SIS#
Approved: _____	

**BB48HC BACK BAR REFRIGERATOR: FOOD RATED**

## BAR EQUIPMENT- BACK BAR REFRIGERATOR

**MODEL:  
BB48HC-1-F-GS-S**

BB48HC Sliding Glass Door Food Rated  
Hydrocarbon Series

**3 Year Parts/Labor Warranty  
Additional 4 Year Compressor Warranty**



### CABINET CONSTRUCTION

- Exterior is stainless steel front and sides
- Stainless steel interior
- Full electronic control
- Galvanized sub-top standard
- Four (4) epoxy coated shelves
- Self-closing sliding glass doors have black frame regardless of finish
- Stay-open feature and locks standard
- Magnetic door gaskets provide positive door sealing
- LED lighting
- Certified for open food product
- Compressor available on left or right, specify at time of unit order
- Balanced, forced air refrigeration system provides rapid chilling of product

### OPTIONS & ACCESSORIES

- 2" Stainless steel top
- Wine model (40°-60° models)
- Wire shelf divider
- Additional shelves
- Additional shelf clips
- 3" or 6" Casters
- 6" Black legs
- Remote option\* (see note on back on page)

### REFRIGERATION SYSTEM

- Uses environmentally friendly, energy efficient R290 refrigerant, and meets all regulatory requirements for CARB, SNAP, DOE & more
- Adaptive defrost
- Epoxy coated evaporator coil
- Maintains product temperature between 36°F and 38°F



  
Please verify qualifying units by visiting:  
[www.energystar.gov/cfs](http://www.energystar.gov/cfs)

3779 Champion Blvd., Winston-Salem, NC 27105  
1-888-845-9800 Fax: 1-336-245-6453  
Beverage-Air.com Sales@bevair.com



# BEVERAGE-AIR

MODEL	BB48HC-1-F-GS-S
<b>EXTERNAL DIMENSIONAL DATA</b>	
Width Overall	48"
Depth Overall	23 <sup>5</sup> / <sub>8</sub> "
Height Overall	34"
Number of Doors	2
Door Openings (in)	17" x 26 <sup>1</sup> / <sub>4</sub> "
<b>INTERNAL DIMENSIONAL DATA</b>	
NET Capacity (cubic ft.)	12.4
Internal Width Overall (in)	44 <sup>7</sup> / <sub>8</sub> "
Internal Depth Overall (in)	18 <sup>1</sup> / <sub>4</sub> "
Internal Height Overall (in)	29 <sup>1</sup> / <sub>2</sub> "
Number of Shelves	4
Number of 1/2 Kegs	2
<b>ELECTRICAL DATA</b>	
Full Load Amperes	2.5
<b>REFRIGERATION DATA</b>	
Horsepower	1/4
Capacity (BTU/Hr)	1702
Heat Rejection (BTU/Hr)	2553
Charge (lbs/grams)	0.1984/90
<b>SHIPPING DATA</b>	
Gross Weight - Crated	284 lbs
Height - Crated	43"
Width - Crated	51"
Depth - Crated	27"

\*NOTE: Remote units are field wired and come with 6" legs.  
Refrigerant must be specified at time of order.

## Bar Equipment-Back Bar Refrigerator Model: BB48HC-1-F-GS-S

### Model Views

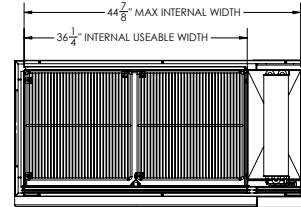

### PLAN VIEW

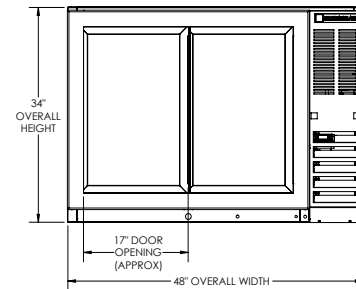

### ELEVATION VIEW

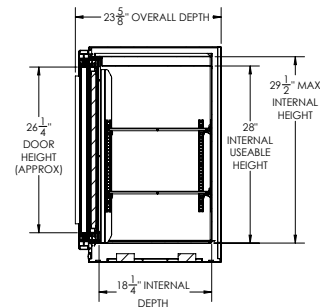

### SIDE VIEW

### ELECTRICAL CONNECTION



115/60/1  
NEMA 5-15P

Unit pre-wired at factory and include 8' long cord and plug set.



3779 Champion Blvd., Winston-Salem, NC 27105 1-888-845-9800 Fax: 1-336-245-6453 Beverage-Air.com Sales@bevoir.com

an Ali Group Company



The Spirit of Excellence