



BEVERAGE-AIR

Project: _____	AIA#
Item: _____	
Location: _____	SIS#
Approved: _____	

DD58HC DIRECT DRAW DISPENSER: CLUB TOP

DRAFT BEER EQUIPMENT-DIRECT DRAW DISPENSER

**MODEL:
DD58HC-1-C-B**

DD58HC Solid Door Club Top Dual Towers With Single Faucets
Hydrocarbon Series



**3 Year Parts/Labor Warranty
Additional 4 Year Compressor Warranty**

CABINET CONSTRUCTION

- Exterior features durable black painted steel with galvanized steel back
- Top is made from heavy-duty stainless steel including drip tray
- Interior is galvanized steel on walls and ceiling, reinforced floor and doorsill are heavy-duty stainless steel
- Club top, easy glide stainless steel lids for additional storage of glasses, cans or bottles, includes (1) epoxy coated shelf and (1) basket
- Full electronic control
- Dual towers with single faucets
- 3-in-1 Draft solution uses a single stainless-steel tap to serve different beverages, such as wine, beer, and coffee (or other non-alcoholic beverages) through silver-lined, anti-microbial tubing that is 100% effective against the top 4 beverage spoiling bacteria
- 3" Stainless steel insulated dispensing tower
- Drain tube located at bottom front of cooler for connection to floor drain
- Door locks
- Self-closing doors with 120° stay-open feature
- Magnetic gaskets provide positive door seal
- Field reversible doors (hinge kit not included)
- Compressor available on left or right, specify at time of unit order

OPTIONS & ACCESSORIES

- Stainless steel interior lining
- Stainless steel back
- Glass door
- Shelves
- Shelf clips
- Wine/coffee models
- Faucet locks
- Glass rinser
- Right or left hinged door
- 2"- 3" Casters or 6" black legs
- No draft/hole cover option
- Remote option* (see note on back on page)

REFRIGERATION SYSTEM

- Refrigeration system uses R290 refrigerant to comply with all environmental concerns
- Automatic, non-electric defrost
- Epoxy coated evaporator coil
- Maintains product temperatures between 36°F and 38°F



Please verify qualifying units by visiting:
www.energystar.gov/cfs

3779 Champion Blvd., Winston-Salem, NC 27105
1-888-845-9800 Fax: 1-336-245-6453
Beverage-Air.com Sales@bevair.com



BEVERAGE-AIR

Bar Equipment-Direct Draw Dispenser Club Top Model: DD58HC-1-C-B

MODEL	DD58HC-1-C-B
EXTERNAL DIMENSIONAL DATA	
Width Overall	59"
Depth Overall	29 ¹ / ₁₆ "
Height Overall (floor to top of tap)	52 ⁵ / ₈ "
Number of Doors	2
Depth with Door Open 90°	50 ⁷ / ₁₆ "
Door Openings (in)	21 ¹ / ₁₆ " x 30"
INTERNAL DIMENSIONAL DATA	
NET Capacity (cubic ft.)	21.86
Internal Width Overall (in)	46"
Internal Depth Overall (in)	23 ¹ / ₈ "
Internal Height Overall (in)	27 ³ / ₈ "
Number of 1/2 Kegs	3
ELECTRICAL DATA	
Full Load Amperes	2.5
REFRIGERATION DATA	
Horsepower	1/4
Capacity (BTU/Hr)	1702
Heat Rejection (BTU/Hr)	2553
Charge (lbs/grams)	0.2094/95
SHIPPING DATA	
Gross Weight - Crated	342 lbs
Height - Crated	45"
Width - Crated	62"
Depth - Crated	32"

*NOTE: Remote units are field wired and come with 6" legs.
Refrigerant must be specified at time of order.

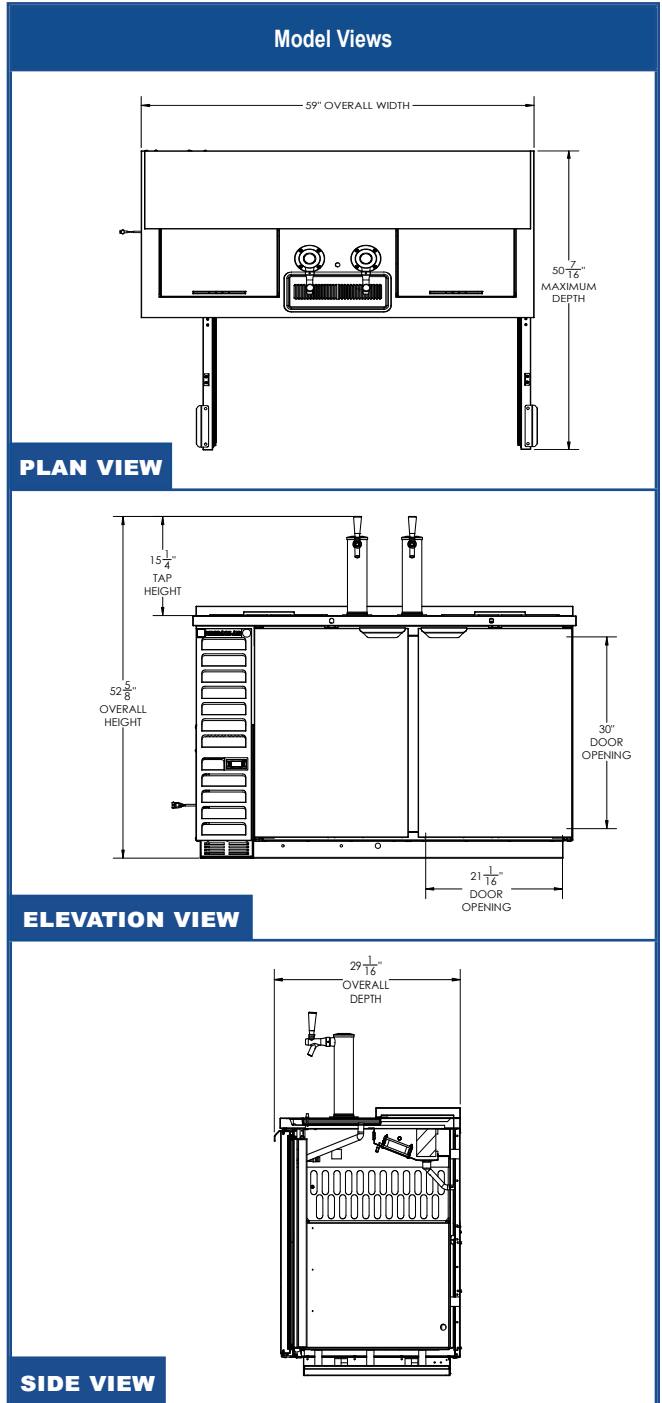
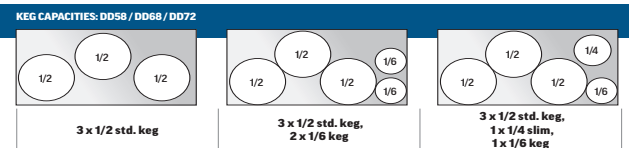

ELECTRICAL CONNECTION



115/60/1
NEMA 5-15P

Unit pre-wired at factory and include 8' long cord and plug set.



3779 Champion Blvd., Winston-Salem, NC 27105 1-888-845-9800 Fax: 1-336-245-6453 Beverage-Air.com Sales@bevoir.com

an Ali Group Company



The Spirit of Excellence