



BEVERAGE-AIR®

Project: _____	AIA#
Item: _____	
Location: _____	SIS#
Approved: _____	

SM49HC SINGLE ACCESS, COLD WALL: SCHOOL MILK SERIES

SCHOOL MILK COLD WALL COOLER

SM49HC Single Access Cooler

Hydrocarbon Series

MODEL:
SM49HC-S



3 Year Parts/Labor Warranty
Additional 4 Year Compressor Warranty

CABINET CONSTRUCTION

- Stainless steel exterior and interior
- Stainless steel lids, hinged door and door latches
- Self-latching doors/lids with safety bumpers
- Full electronic control
- Heavy-duty epoxy coated steel wire floor racks standard
- Floor drain is centrally located for easy cleaning and connecting to drain hose with hose adapter
- Flexible compression door gaskets, ensures a tight seal
- Exterior thermometer
- Cylinder lock
- 4" Heavy-duty plate casters (2 with locks)
- Cold wall milk coolers are designed to hold product temperature during service. Product should be removed at the end of service and moved to long-term, refrigerated storage

OPTIONS & ACCESSORIES

- Corner bumpers
- Cafeteria tray slides
- Graphics

REFRIGERATION SYSTEM

- Uses environmentally friendly, energy efficient R290 refrigerant, and meets all regulatory requirements for CARB, SNAP, DOE & more
- Maintains product temperature between 36°F to 40°F



Please verify qualifying units by visiting:
www.energystar.gov/cfs

3779 Champion Blvd., Winston-Salem, NC 27105
1-888-845-9800 Fax: 1-336-245-6453
Beverage-Air.com Sales@bevair.com



BEVERAGE-AIR

MODEL	SM49HC-S
EXTERNAL DIMENSIONAL DATA	
Width Overall (in)	49"
Depth Overall (in)	30 ⁵ / ₈ "
Height Overall with Casters (in)	41 ¹ / ₈ "
Number of Lids/Doors	Single Access
Depth with Door Open 90° (in)	45 ¹ / ₂ "
INTERNAL DIMENSIONAL DATA	
NET Capacity (cubic ft.)	20.32
Internal Width Overall (in)	46"
Internal Depth Overall (in)	27"
Internal Height Overall (in)	25 ³ / ₄ "
CASE CAPACITY	
13" X 13" X 11"	12
19" X 13" X 11"	8
ELECTRICAL DATA	
Full Load Amperes	2.2
REFRIGERATION DATA	
Horsepower	1/3
Capacity (BTU/Hr)	1367
Heat Rejection (BTU/Hr)	2050.5
Charge (lbs/grams)	0.1764/80
SHIPPING DATA	
Gross Weight - Crated	338 lbs
Height - Crated	48"
Width - Crated	52"
Depth - Crated	34"

School Milk Cooler - Single Access

Model: SM49HC-S

Model Views

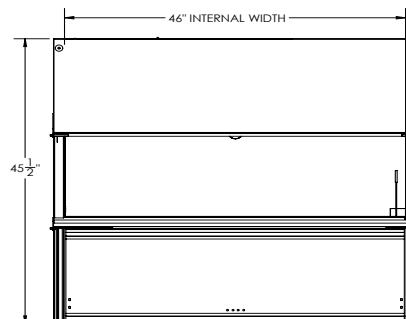

PLAN VIEW

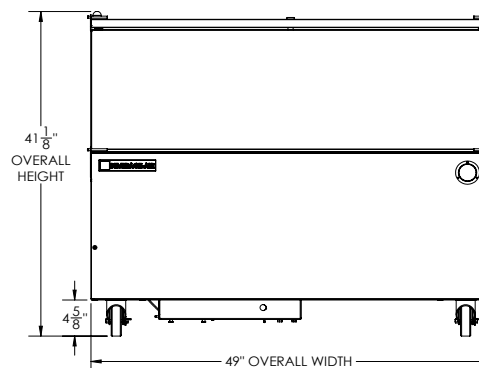

ELEVATION VIEW

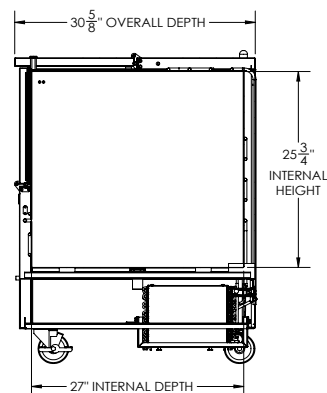

SIDE VIEW

ELECTRICAL CONNECTION



115/60/1
NEMA 5-15P

Units pre-wired at factory and include 8' long cord and plug set.



3779 Champion Blvd., Winston-Salem, NC 27105 1-888-845-9800 Fax: 1-336-245-6453 Beverage-Air.com Sales@bevoir.com

an Ali Group Company



The Spirit of Excellence