



BEVERAGE-AIR

Project: _____	AIA#
Item: _____	
Location: _____	SIS#
Approved: _____	

SMF49HC SINGLE ACCESS, FORCED AIR: SCHOOL MILK SERIES

SCHOOL MILK FORCED AIR COOLER

SMF49HC Single Access Cooler
Hydrocarbon Series

MODEL:
SMF49HC-1-W



3 Year Parts/Labor Warranty
Additional 4 Year Compressor Warranty

CABINET CONSTRUCTION

- White coated steel exterior
- Interior features a one-piece, stainless steel back, front, floor with galvanized side walls for maximum milk crate support
- Stainless steel lids, hinged door and door latches
- Full electronic control
- Heavy-duty epoxy coated steel wire floor racks standard
- Floor drain is centrally located for easy cleaning, connecting to drain hose with hose adapter
- Flexible compression door gaskets, ensures a tight seal
- Self-latching doors/lids with safety bumpers
- Exterior thermometer
- Cylinder lock
- 6" Heavy-duty plate casters (2 with locks)
- Balanced, forced-air refrigeration system provides rapid chilling of product

OPTIONS & ACCESSORIES

- Stainless steel interior on white models -02
- Corner bumpers
- Cafeteria tray slides
- Graphics

REFRIGERATION SYSTEM

- Uses environmentally friendly, energy efficient R290 refrigerant, and meets all regulatory requirements for CARB, SNAP, DOE & more
- Maintains product temperature between 36°F to 40°F



Please verify qualifying units by visiting:
www.energystar.gov/cfs

3779 Champion Blvd., Winston-Salem, NC 27105
1-888-845-9800 Fax: 1-336-245-6453
Beverage-Air.com Sales@bevair.com



BEVERAGE-AIR

School Milk Cooler - Single Access

Model: SMF49HC-1-W

MODEL	SMF49HC-1-W
EXTERNAL DIMENSIONAL DATA	
Width Overall (in)	49"
Depth Overall (in)	33 5/8"
Height Overall with Casters (in)	47"
Number of Lids/Doors	Single Access
Depth with Door Open 90° (in)	48 1/2"
INTERNAL DIMENSIONAL DATA	
NET Capacity (cubic ft.)	19.66
Internal Width Overall (in)	46"
Internal Depth Overall (in)	30"
Internal Height Overall (in)	24 7/8"
CASE CAPACITY	
13" X 13" X 11"	12
19" X 13" X 11"	8
ELECTRICAL DATA	
Full Load Amperes	2.46
REFRIGERATION DATA	
Horsepower	1/4
Capacity (BTU/Hr)	1851
Heat Rejection (BTU/Hr)	2776.5
Charge (lbs/grams)	0.154/70
SHIPPING DATA	
Gross Weight - Crated	437 lbs
Height - Crated	54"
Width - Crated	54"
Depth - Crated	38"

Model Views

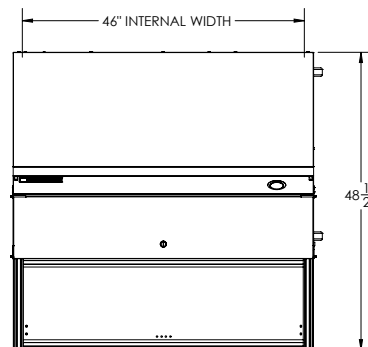

PLAN VIEW

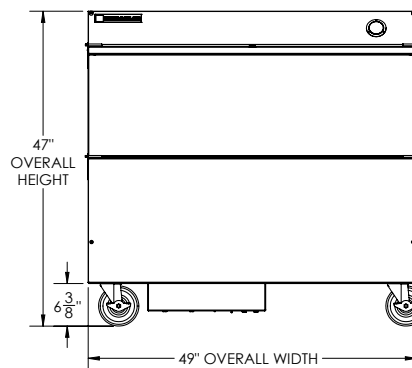

ELEVATION VIEW

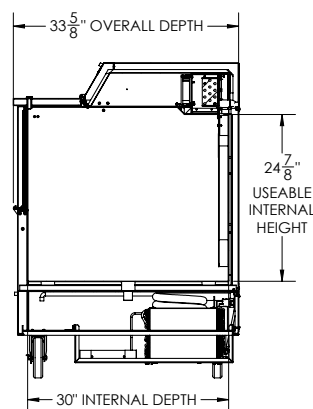

SIDE VIEW

ELECTRICAL CONNECTION



115/60/1
NEMA 5-15P

Units pre-wired at factory and include 8' long cord and plug set.



3779 Champion Blvd., Winston-Salem, NC 27105 1-888-845-9800 Fax: 1-336-245-6453 Beverage-Air.com Sales@bevair.com

an Ali Group Company



The Spirit of Excellence