



# BEVERAGE-AIR®

Project: _____	AIA#
Item: _____	
Location: _____	SIS#
Approved: _____	

**SMF49HC SINGLE ACCESS, FORCED AIR: SCHOOL MILK SERIES**

## SCHOOL MILK FORCED AIR COOLER

SMF49HC Single Access Cooler  
Hydrocarbon Series

**MODEL:**  
**SMF49HC-1-W-02**



**3 Year Parts/Labor Warranty**  
**Additional 4 Year Compressor Warranty**

### CABINET CONSTRUCTION

- White coated steel exterior
- Stainless steel interior
- Stainless steel lids, hinged door and door latches
- Full electronic control
- Heavy-duty epoxy coated steel wire floor racks standard
- Floor drain is centrally located for easy cleaning, connecting to drain hose with hose adapter
- Flexible compression door gaskets, ensures a tight seal
- Self-latching doors/lids with safety bumpers
- Exterior thermometer
- Cylinder lock
- 6" Heavy-duty plate casters (2 with locks)
- Balanced, forced-air refrigeration system provides rapid chilling of product

### OPTIONS & ACCESSORIES

- Corner bumpers
- Cafeteria tray slides
- Graphics

### REFRIGERATION SYSTEM

- Uses environmentally friendly, energy efficient R290 refrigerant, and meets all regulatory requirements for CARB, SNAP, DOE & more
- Maintains product temperature between 36°F to 40°F



  
Please verify qualifying units by visiting:  
[www.energystar.gov/cfs](http://www.energystar.gov/cfs)

3779 Champion Blvd., Winston-Salem, NC 27105  
1-888-845-9800 Fax: 1-336-245-6453  
Beverage-Air.com Sales@bevair.com



# BEVERAGE-AIR

## School Milk Cooler - Single Access

Model: SMF49HC-1-W-02

MODEL	SMF49HC-1-W-02
<b>EXTERNAL DIMENSIONAL DATA</b>	
Width Overall (in)	49"
Depth Overall (in)	33 5/8"
Height Overall with Casters (in)	47"
Number of Lids/Doors	Single Access
Depth with Door Open 90° (in)	48 1/2"
<b>INTERNAL DIMENSIONAL DATA</b>	
NET Capacity (cubic ft.)	19.66
Internal Width Overall (in)	46"
Internal Depth Overall (in)	30"
Internal Height Overall (in)	24 7/8"
<b>CASE CAPACITY</b>	
13" X 13" X 11"	12
19" X 13" X 11"	8
<b>ELECTRICAL DATA</b>	
Full Load Amperes	2.46
<b>REFRIGERATION DATA</b>	
Horsepower	1/4
Capacity (BTU/Hr)	1851
Heat Rejection (BTU/Hr)	2776.5
Charge (lbs/grams)	0.154/70
<b>SHIPPING DATA</b>	
Gross Weight - Crated	437 lbs
Height - Crated	54"
Width - Crated	54"
Depth - Crated	38"

### Model Views

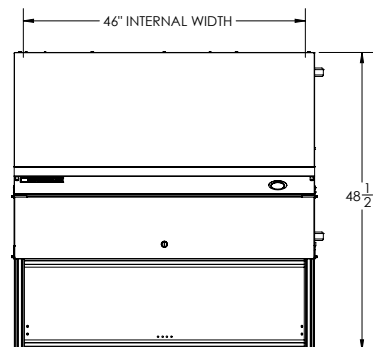

### PLAN VIEW

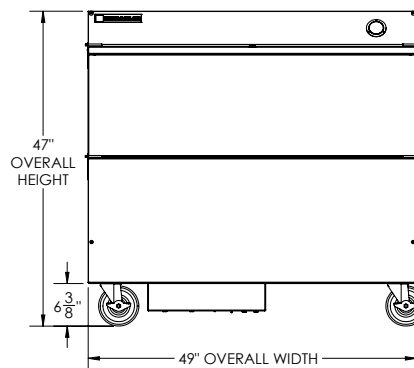

### ELEVATION VIEW

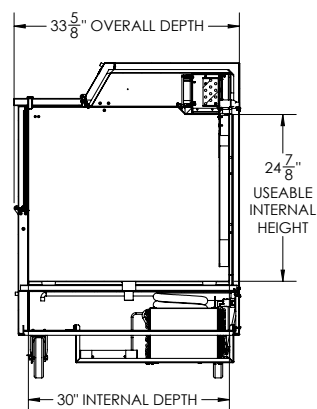

### SIDE VIEW

### ELECTRICAL CONNECTION



115/60/1  
NEMA 5-15P

Units pre-wired at  
factory and include 8'  
long cord and plug set.



3779 Champion Blvd., Winston-Salem, NC 27105 1-888-845-9800 Fax: 1-336-245-6453 Beverage-Air.com Sales@bevoir.com

an Ali Group Company



The Spirit of Excellence