



# BEVERAGE-AIR

Project: _____	AIA#
Item: _____	
Location: _____	SIS#
Approved: _____	

**STF49HC DUAL ACCESS, FORCED AIR: SCHOOL MILK SERIES**

## SCHOOL MILK FORCED AIR COOLER

### STF49HC Dual Access Cooler

Hydrocarbon Series

**MODEL:**  
STF49HC-1-S



**3 Year Parts/Labor Warranty**  
**Additional 4 Year Compressor Warranty**

#### CABINET CONSTRUCTION

- Stainless steel exterior and interior
- Stainless steel lids, hinged doors and door latches
- Full electronic control
- Dual sided access
- Heavy-duty epoxy coated steel wire floor racks standard
- Floor drain is centrally located for easy cleaning and connecting to drain hose with hose adapter
- Flexible compression door gaskets, ensures a tight seal
- Self-latching doors/lids with safety bumpers
- Exterior thermometer
- Cylinder locks
- 5" Heavy-duty plate casters (2 with locks)
- Balanced, forced-air refrigeration system provides rapid chilling of product

#### OPTIONS & ACCESSORIES

- Corner bumpers
- Cafeteria tray slides
- Graphics

#### REFRIGERATION SYSTEM

- Uses environmentally friendly, energy efficient R290 refrigerant, and meets all regulatory requirements for CARB, SNAP, DOE & more
- Maintains product temperature between 36°F- 40°F



Please verify qualifying units by visiting:  
[www.energystar.gov/cfs](http://www.energystar.gov/cfs)

3779 Champion Blvd., Winston-Salem, NC 27105  
1-888-845-9800 Fax: 1-336-245-6453  
Beverage-Air.com Sales@bevair.com



# BEVERAGE-AIR

## School Milk Cooler - Dual Access Model: STF49HC-1-S

MODEL	STF49HC-1-S
<b>EXTERNAL DIMENSIONAL DATA</b>	
Width Overall	49"
Depth Overall	34"
Height Overall with Casters	47 <sup>3</sup> / <sub>4</sub> "
Number of Lids/Doors	Dual Access
Both Lids Extended	64"
<b>INTERNAL DIMENSIONAL DATA</b>	
NET Capacity (cubic ft.)	20.55
Internal Width Overall (in)	46"
Internal Depth Overall (in)	30"
Internal Height Overall (in)	24 <sup>5</sup> / <sub>8</sub> "
<b>CASE CAPACITY</b>	
13" X 13" X 11"	12
19" X 13" X 11"	8
<b>ELECTRICAL DATA</b>	
Full Load Amperes	2.46
<b>REFRIGERATION DATA</b>	
Horsepower	1/4
Capacity (BTU/Hr)	1851
Heat Rejection (BTU/Hr)	2776.5
Charge (lbs/grams)	0.154/70
<b>SHIPPING DATA</b>	
Gross Weight - Crated	334 lbs
Height - Crated	55"
Width - Crated	54"
Depth - Crated	38"

### Model Views

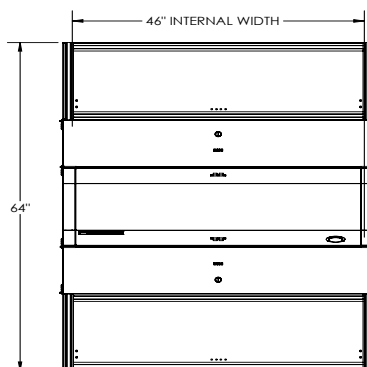

### PLAN VIEW

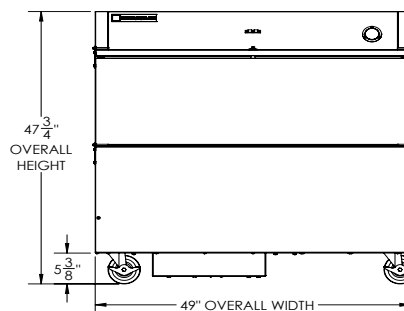

### ELEVATION VIEW

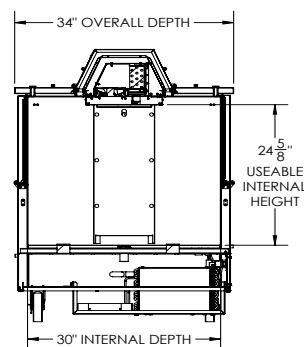

### SIDE VIEW

### ELECTRICAL CONNECTION



115/60/1  
NEMA 5-15P

Units pre-wired at  
factory and include 8'  
long cord and plug set.



3779 Champion Blvd., Winston-Salem, NC 27105 1-888-845-9800 Fax: 1-336-245-6453 Beverage-Air.com Sales@bevoir.com

an Ali Group Company



The Spirit of Excellence