

Job: \_\_\_\_\_

Item: \_\_\_\_\_

Quantity: \_\_\_\_\_

## Lug Dollies - 6000 Series

- Ideal for bulk food transporting.
- Accepts the standard lugs (16"W x 8½"H x 25"L).

**MATERIAL:**

- Framework is constructed out of 1 ¼" x 1 ¼" x .070" wall tubing.
- Angle runners are 1 ¼" x 1 ¼" x .100" wall angle.

**CASTERS:**

- Equipped with four 5" stem type swivel casters.

**GUARANTEE:**

- Lifetime Guarantee against rust and corrosion.
- One-Year Guarantee against material defects and workmanship.

NSF Certified. 

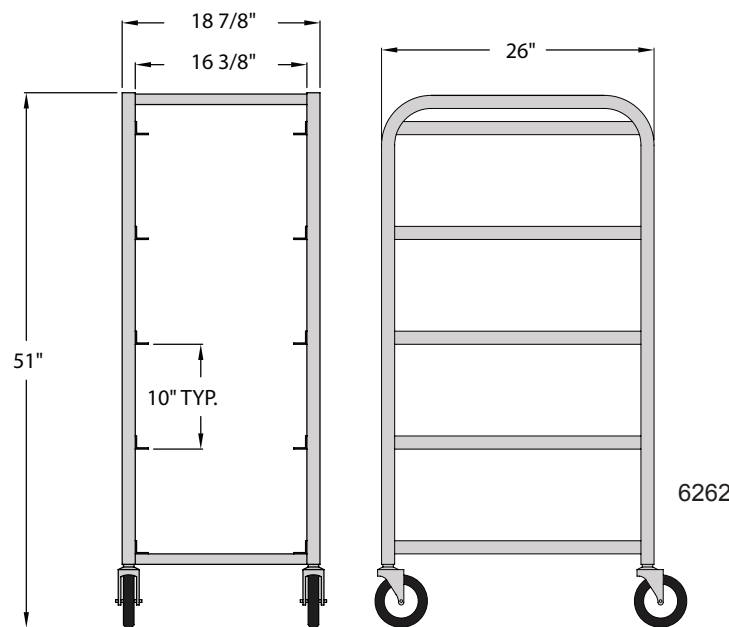

Model No.	Lug Cap.	Size W-H-L	Ship Lbs.
6265	1	16 ¾" x 19" x 27"	10
6266	2	16 ¾" x 33" x 29 ¼"	16
97205*	3	19 ¾" x 41" x 26 ¾"	23
6262	4	19 ¾" x 51" x 26 ¾"	25
97253*	5	19 ¾" x 61" x 26 ¾"	28
6263	6	19 ¾" x 71" x 26 ¾"	31

Four 5" swivel type stem casters (#C480) - No brakes.

\* Not NSF Approved.

**Options:**

"CL(A)" — See page 69 for details.

*This information is for general sales and engineering use only. New Age Industrial reserves the right to modify or make changes at any time without notice to materials and specifications.*

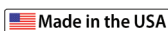

Distributed by: