



Job _____ Item No. _____

Wells Countertop Electric Fryer

Single Pot/Twin Baskets □LLF14 □F15

Twin Pots/Single Basket □F30



F15

DESCRIPTION

Wells electric fryers are built for maximum efficiency and quick product turn-around. These units come in a variety of sizes and are designed for countertop operation to fit a variety of operations and locations.

SPECIFICATIONS

Wells electric fryers will be constructed with a stainless steel body and will have a stainless steel kettle. These will use immersion heating elements, which swing up for easy cleaning. Fryers will have a removable stainless steel kettle for easy straining of oil/fat. The fryers will use snap-action thermostats that allow for a temperature range of 200°F (93°C) to 375°F (191°C). Two baskets will be supplied with each fryer. LLF14 and F15 models will come wired with an appropriate plug based on the model's power ratings and certification requirements. F30 models will be set up to hard wire and will not included a cord or plug. All units will have a built in high limit safety thermostat. F15 and F30 models will be UL and cUL certified. LLF14 models will be UL certified only.

WARRANTY

These units come with a one [1] year warranty for parts and labor.

FEATURES

- Snap-action thermostats provide responsive temperature control from 200°F (93°C) to 375°F (191°C)
- Immersion-type heating elements provide even heat distribution and swing up for simple maintenance
- Removable baskets allowing for easy rotation and cleaning
- Kettles are easily removable for straining
- Compact design for maximum cooking while using minimal counter space
- Safety thermostat to avoid potentially dangerous temperatures

MODEL	514LL	F15	F30
OIL CAPACITY	14 lb. (6.4 kg)	15 lb. (6.8 kg)	30 lb. (13.6 kg)

OPTIONS & ACCESSORIES

- Extra fry baskets [left side ends in L, right side in R]
 - 21506**—Same as those that come with LLF14 models
 - 515FBL/515FBR**—Same as those that come with F15 model and as a pair can replace one 530FBL or one 530FBR on F30 models
 - 530FBL/530FBR**—Same as those that come with F30 models and can replace a pair of baskets on F15 models to use a single basket

CERTIFICATIONS



¹LLF14 is not cUL/CSA certified



WELLS MANUFACTURING • www.wells-mfg.com
265 Hobson Street • Smithville, Tennessee 37166
Telephone 888 356 5362 • Fax 314 781 5445

Printed in the U.S.A. • 2M-Z21738 • Rev. A • 04.2018
Specifications are subject to change without notice and are not intended for installation purposes.



Wells Countertop Electric Fryer

Single Pot/Twin Baskets □LLF14 □F15

Twin Pots/Single Basket □F30

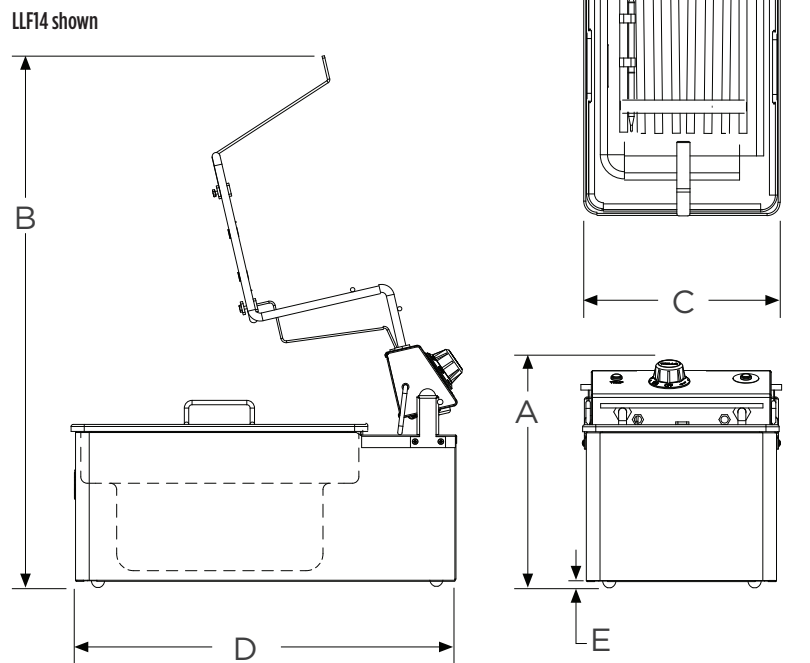

MODEL	DISTANCE TO ELECTRICAL CONNECTION		
	FROM LEFT	FROM BOTTOM [located on back]	FROM BACK [located on bottom]
LLF14 ²	2.5 in. (64 mm)	11.4 in. (290 mm)	
F15	6 in. (152 mm)		1.25 in. (32 mm)
F30	12 in. (305 mm)		1.3 in. (33 mm)

MODEL	DISTANCE FROM LEGS TO EDGE OF BODY		
	FRONT	BACK	SIDE
LLF14 ²	1.4 in. (36 mm)	1 in. (25 mm)	1.3 in. (33 mm)
F15	1.9 in. (48 mm)	4 in. (102 mm)	0.3 in. (8 mm)
F30	2.1 in. (53 mm)	4.1 in. (104 mm)	0.3 in. (8 mm)

MODEL	OPERATING [A]/CLEANING [B] HEIGHT in. (mm)	WIDTH [C] in. (mm)	DEPTH [D] in. (mm)	LEG HEIGHT [E] in. (mm)	Volts	KW	AMPS	NEMA PLUG	APPROX. SHIPPING WEIGHT	APPROX. DRY WEIGHT INSTALLED
LLF14 ²	13.3/30.4 (338/772)	11.4 (290)	21.8 (554)	0.375 (10)	120	1.8	15	5-15P	34 lb.	31 lb.
F15	16.6/37.8 (422/960)	12 (305)	24.8 (630)	4 (102)	208/240	4.3/5.8	20.8/24	6-30P	47 lb.	38 lb.
F30	16.6/37.8 (422/960)	24 (610)	24.8 (630)	4 (102)	208/240 230	8.6/11.5 8.5	41.5/47.9 37	not included	80 lb.	65 lb.

²not cUL/CSA approved

Due to periodic changes in designs, methods, procedures, policies and regulations, the specifications contained in this sheet are subject to change without notice. While Star Manufacturing exercises good faith efforts to provide information that is accurate, we are not responsible for errors or omissions in information provided or conclusions reached as a result of using the specifications. By using the information provided, the user assumes all risks in connection with such use.



WELLS MANUFACTURING • www.wells-mfg.com
 265 Hobson Street • Smithville, Tennessee 37166
 Telephone 888 356 5362 • Fax 314 781 5445

Printed in the U.S.A. • 2M-Z21738 • Rev. A • 04.2018
 Please refer to the owner's manual for information regarding installation or use.