

# 500-HW Series

## Waterless Hot Food Well

UL Listed

ALTO-SHAAM

Unlike traditional steam tables or dry wells, waterless hot food wells from Alto-Shaam feature radiant Halo Heat® technology that evenly surrounds food without the use of extremely hot elements, added humidity or fans. Extend hold times, maintain food quality and reduce operating costs to maximize return on investment.



500-HW

### Standard Features

- Extend food holding times with efficient, precise Halo Heat® technology
- Maintain food quality without the use of extremely hot elements, added humidity or fans
- Increase sales with attractive food presentation and quality
- Reduce installation and operating costs with no water or plumbing needed
- Save on maintenance costs, eliminating lime and scale buildup associated with traditional steam tables
- Increase employee and customer safety with elimination of hot water and steam
- Provide optimal holding temperatures with an adjustable thermostat that can be flush-mounted into the counter or a location out of sight from customers
- Set ideal holding temperatures for any dish with an individual well control option
- HWLF models feature a large flange
- HWI and HWILF models are controlled by two [2] separate adjustable thermostats
- 500-HW/D4, 500-HW/D6, 500-HWLF/D4, and 500-HWLF/D6 models include ten [10] half/third-size divider bars and four [4] large pan divider bars
- 500-HWI/D4, 500-HWI/D6, 500-HWILF/D4, and 500-HWILF/D6 models include ten [10] half/third-size divider bars

### Configurations (select one)

- 500-HW/D4
- 500-HW/D6
- 500-HWLF/D4
- 500-HWLF/D6
- 500-HWI/D4
- 500-HWI/D6
- 500-HWILF/D4
- 500-HWILF/D6

### Electrical

- 120V
- 208V–240V
- 230V

### Control box cord location

- Back, standard
- Bottom, optional

### Accessories (select all that apply)

- Pan divider bar—half-size/third-size [11318]
- Pan divider bar—full-size [16019]
- Locking kit [5020849]



5  
10  
15

- Five full-size or GN 1/1 pans
- Ten half-size or GN 1/2 pans
- Fifteen third-size or GN 1/3 pans

D4: 120 lb [54 kg] product maximum\*

D4: 72.5 qt [70 L] volume maximum\*

\*Based on 4" [100mm] deep pans. Will also accept 2-1/2" [65mm] deep pans; D6 hot wells will accept 6" [150mm] deep pans.



IP X3



# 500-HW Series

## Specification

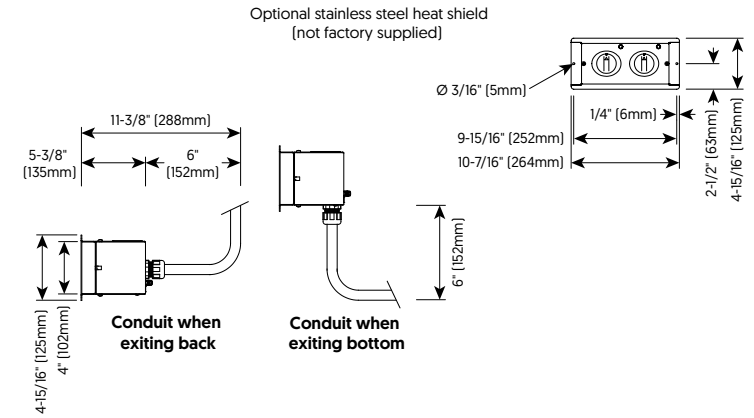
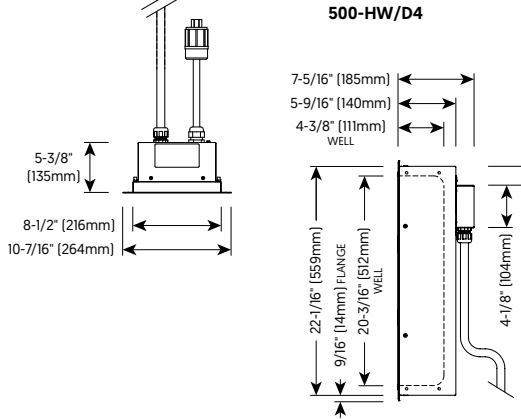
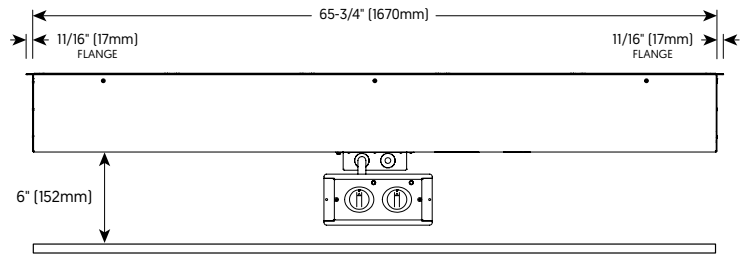
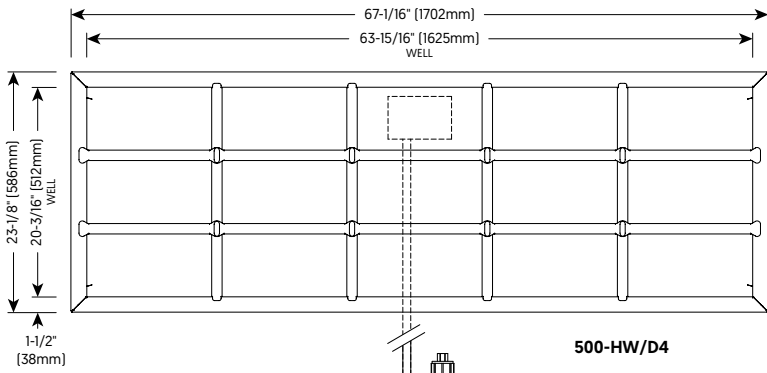

# 500-HWLF Series

## Specification

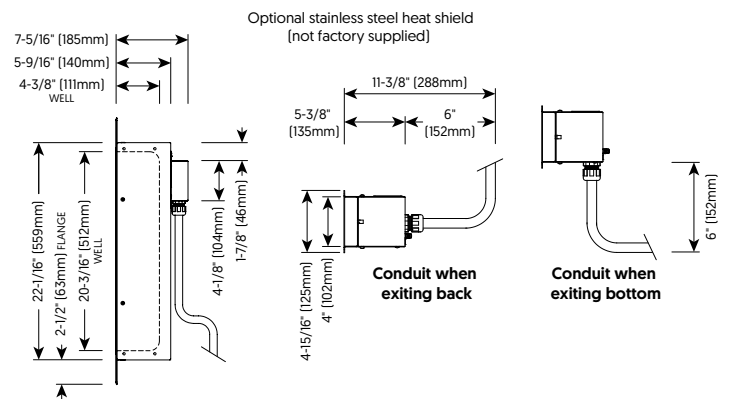
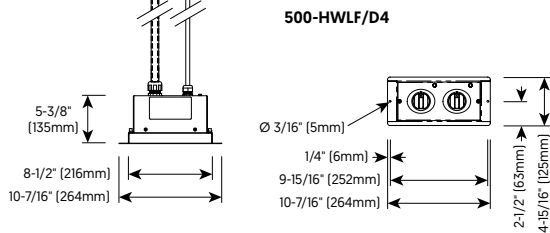
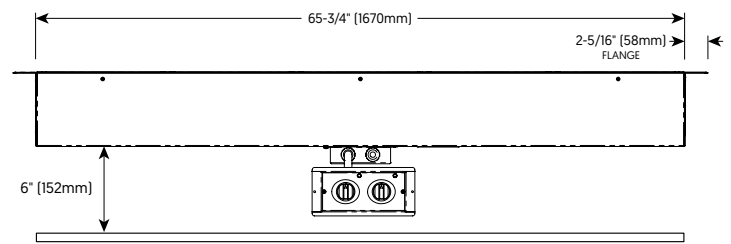
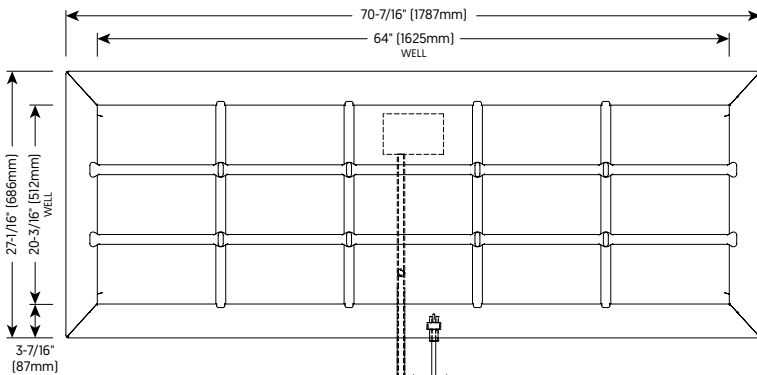

# 500-HWI Series

## Specification

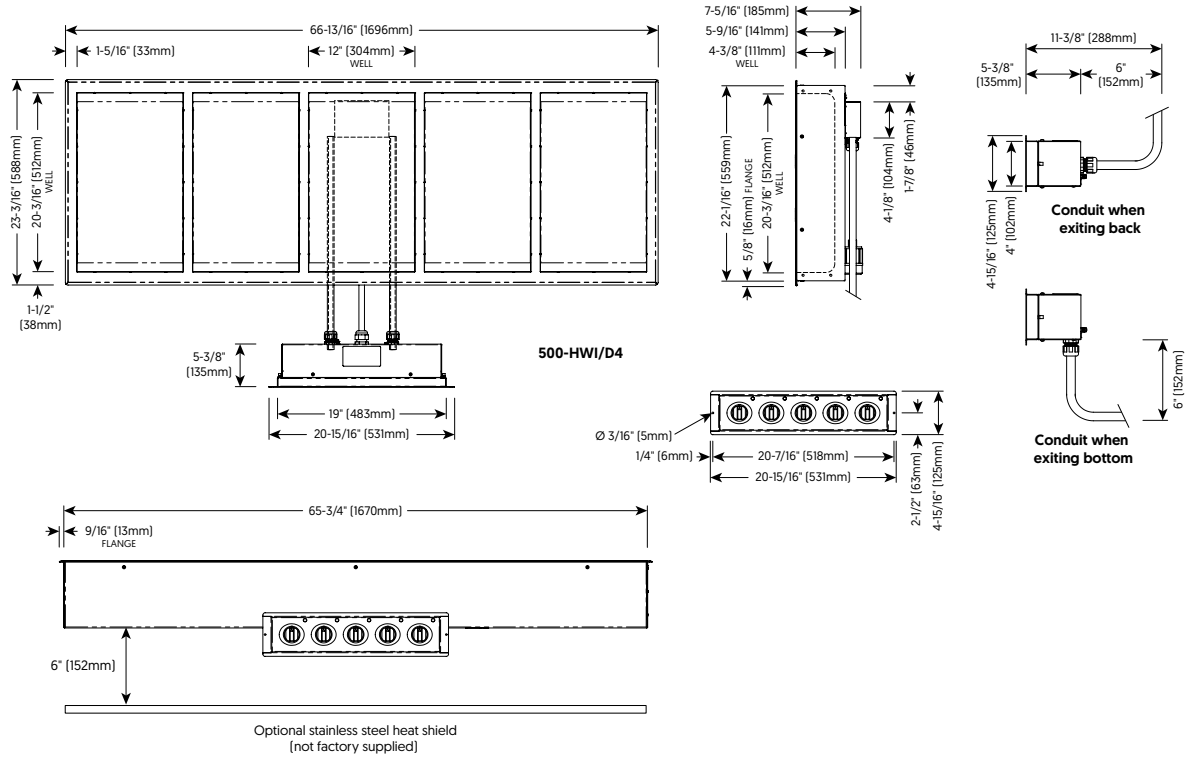

# 500-HWILF Series

## Specification

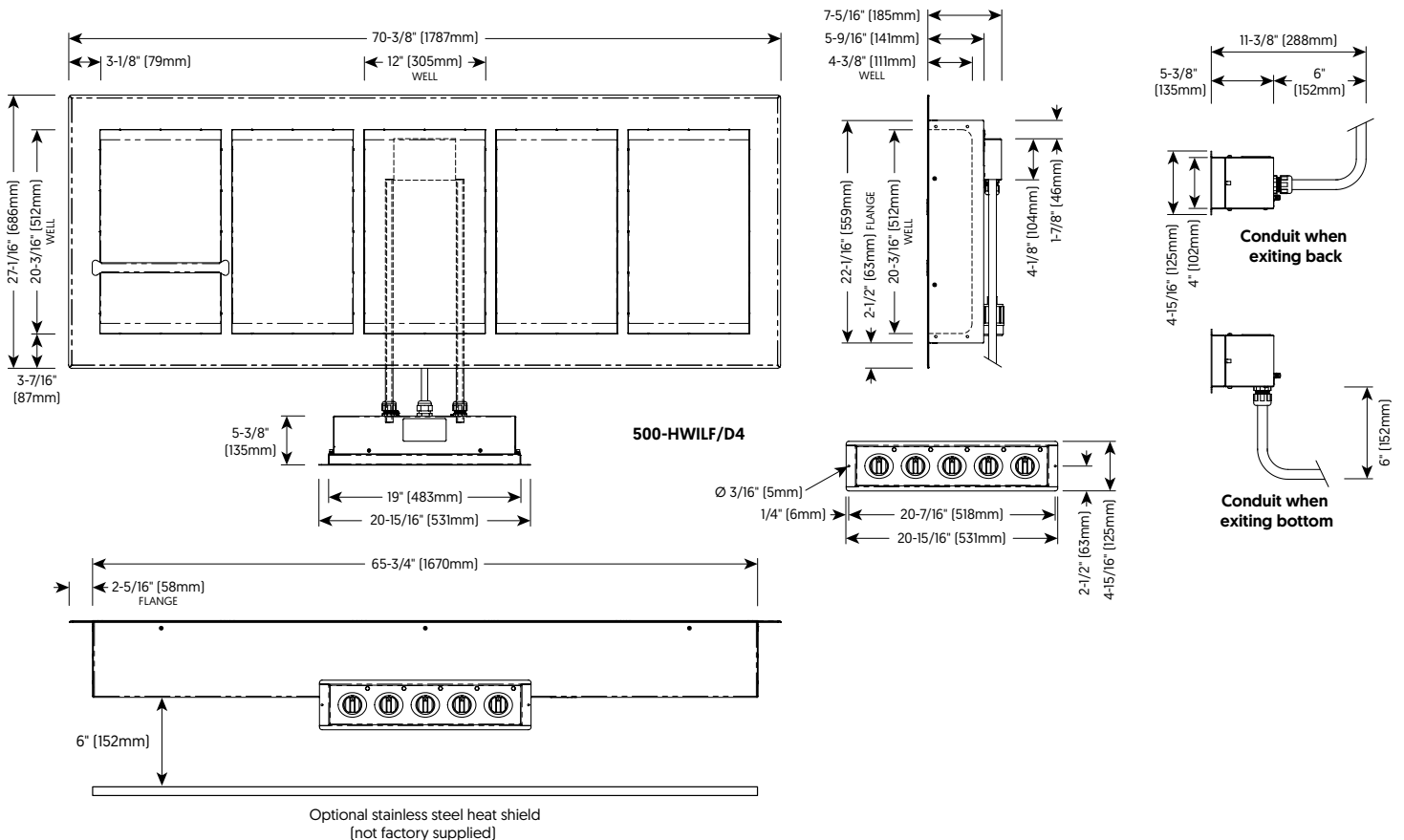

# 500-HW Series



Model	Exterior (H x W x D)
500-HW/D4	7-5/16" x 67-1/16" x 23-1/8" [185mm x 1702mm x 586mm]
500-HW/D6	9-5/16" x 67-1/16" x 23-1/8" [235mm x 1702mm x 586mm]
500-HWLF/D4	7-5/16" x 70-7/16" x 27-1/16" [185mm x 1787mm x 686mm]
500-HWLF/D6	9-1/4" x 70-7/16" x 27-1/16" [234mm x 1787mm x 686mm]
500-HWI/D4	7-5/16" x 66-13/16" x 23-3/16" [185mm x 1696mm x 588mm]
500-HWI/D6	9-5/16" x 66-13/16" x 23-3/16" [235mm x 1696mm x 586mm]
500-HWILF/D4	7-5/16" x 70-3/8" x 27-1/16" [185mm x 1787mm x 686mm]
500-HWILF/D6	9-5/16" x 70-3/8" x 27-1/16" [225mm x 1787mm x 686mm]

Interior (H x W x D)
4-3/8" x 63-15/16" x 20-3/16" [111mm x 1625mm x 512mm]
6-3/8" x 63-15/16" x 20-3/16" [162mm x 1625mm x 512mm]
4-3/8" x 64" x 20-3/16" [111mm x 1625mm x 512mm]
6-3/8" x 64" x 20-3/16" [162mm x 1625mm x 512mm]
4-3/8" x 12" x 20-3/16" [111mm x 304mm x 512mm]
6-3/8" x 12" x 20-3/16" [162mm x 304mm x 512mm]
4-3/8" x 12" x 20-3/16" [111mm x 304mm x 512mm]
6-3/8" x 12" x 20-3/16" [162mm x 304mm x 512mm]

Model	Net Weight	Ship Weight**
500-HW/D4	85 lb [39 kg]	125 lb [57 kg]
500-HW/D6	94.5 lb [43 kg]	170 lb [77 kg]
500-HWLF/D4	89.5 lb [41 kg]	220 lb [100 kg]
500-HWLF/D6	100 lb [45 kg]	175 lb [79 kg]
500-HWI/D4	107 lb [49 kg]	180 lb [82 kg]
500-HWI/D6	121 lb [55 kg]	150 lb [68 kg]
500-HWILF/D4	115 lb [52 kg]	Contact factory
500-HWILF/D6	128.5 lb [58 kg]	150 lb [68 kg]

Ship Dimensions (L x W x H)**
72" x 34" x 15" [1829mm x 864mm x 381mm]
72" x 34" x 15" [1829mm x 864mm x 381mm]
72" x 34" x 15" [1829mm x 864mm x 381mm]
72" x 34" x 15" [1829mm x 864mm x 381mm]
72" x 34" x 15" [1829mm x 864mm x 381mm]
72" x 34" x 15" [1829mm x 864mm x 381mm]
72" x 34" x 15" [1829mm x 864mm x 381mm]
72" x 34" x 15" [1829mm x 864mm x 381mm]

\*\*Domestic ground shipping information. Contact factory for export weight and dimensions.

## Cutout Dimensions

Model	Non-combustible Surface Cutout (L x W)	Combustible Surface Cutout (L x W)^	Control Box Cutout (H x W x D)*
500-HW/D4	66" x 22-1/8" [1676mm x 562mm]	---	4-1/4" x 8-3/4" x 11-3/8" [108mm x 222mm x 288mm]
500-HW/D6	66" x 22-1/8" [1676mm x 562mm]	---	4-1/4" x 8-3/4" x 11-3/8" [108mm x 222mm x 288mm]
500-HWLF/D4	66" x 22-1/8" [1676mm x 562mm]	68" x 24-1/8" [1727mm x 613mm]	4-1/4" x 8-3/4" x 11-3/8" [108mm x 222mm x 288mm]
500-HWLF/D6	66" x 22-1/8" [1676mm x 562mm]	68" x 24-1/8" [1727mm x 613mm]	4-1/4" x 8-3/4" x 11-3/8" [108mm x 222mm x 288mm]
500-HWI/D4	66" x 22-1/8" [1676mm x 562mm]	---	4-1/4" x 19-3/4" x 11-3/8" [108mm x 502mm x 288mm]
500-HWI/D6	66" x 22-1/8" [1676mm x 562mm]	---	4-1/4" x 19-3/4" x 11-3/8" [108mm x 502mm x 288mm]
500-HWILF/D4	66" x 22-1/8" [1676mm x 562mm]	68" x 24-1/8" [1727mm x 613mm]	4-1/4" x 19-3/4" x 11-3/8" [108mm x 502mm x 288mm]
500-HWILF/D6	66" x 22-1/8" [1676mm x 562mm]	68" x 24-1/8" [1727mm x 613mm]	4-1/4" x 19-3/4" x 11-3/8" [108mm x 502mm x 288mm]

\*Large flange wells only.

\*\*Allow 6" [152mm] clearance from control box to conduit bend.



CHECK FIRST

- Appliance must be installed level and must not be installed in any area where it may be directly affected by steam, grease, dripping water, high temperatures, or any other severely adverse conditions.
- Some foods may require additional overhead heating. Always monitor the food temperature and add overhead heating when needed.
- Countertop material must withstand temperatures up to 200°F [93°C].
- A stainless steel heat shield is recommended if the area under the appliance is used for storage.



CLEARANCE

1" [25 mm] from combustible surfaces



ELECTRIC

All models	V	Ph	Hz	A	kW	Cord & Plug
120V	120	1	50/60	25.0	3.0	NEMA L5-30p 30A-125V plug
208-240V	208	1	50/60	10.8	2.3	NEMA 6-15p 15A-250V plug
	240	1	50/60	12.5	3.0	
230V	230	1	50/60	12.0	3.0	CEE 7/7 plug rated 250V CH2-16p plug rated 250V BS 1363 plug rated 250V

Cord length: 120V: 6 ft [1.8 m]; 208-240V: 9 ft [2.7 m]; 230V (CEE): 9 ft [2.7 m]; 230V (CH, BS): 8 ft [2.5 m]



HEAT

Heat of rejection		
500-S	Heat Gain qs, BTU/hr	Heat Gain qs, kW
	304	0.09

## CONTACT US

WI64 N9221 Water Street | Menomonee Falls, Wisconsin 53051 | U.S.A.  
Phone: 262.251.3800 | 800.558.8744 U.S.A./Canada | Fax: 262.251.7067 | [alto-shaam.com](http://alto-shaam.com)